

HearthStone®

Harvest

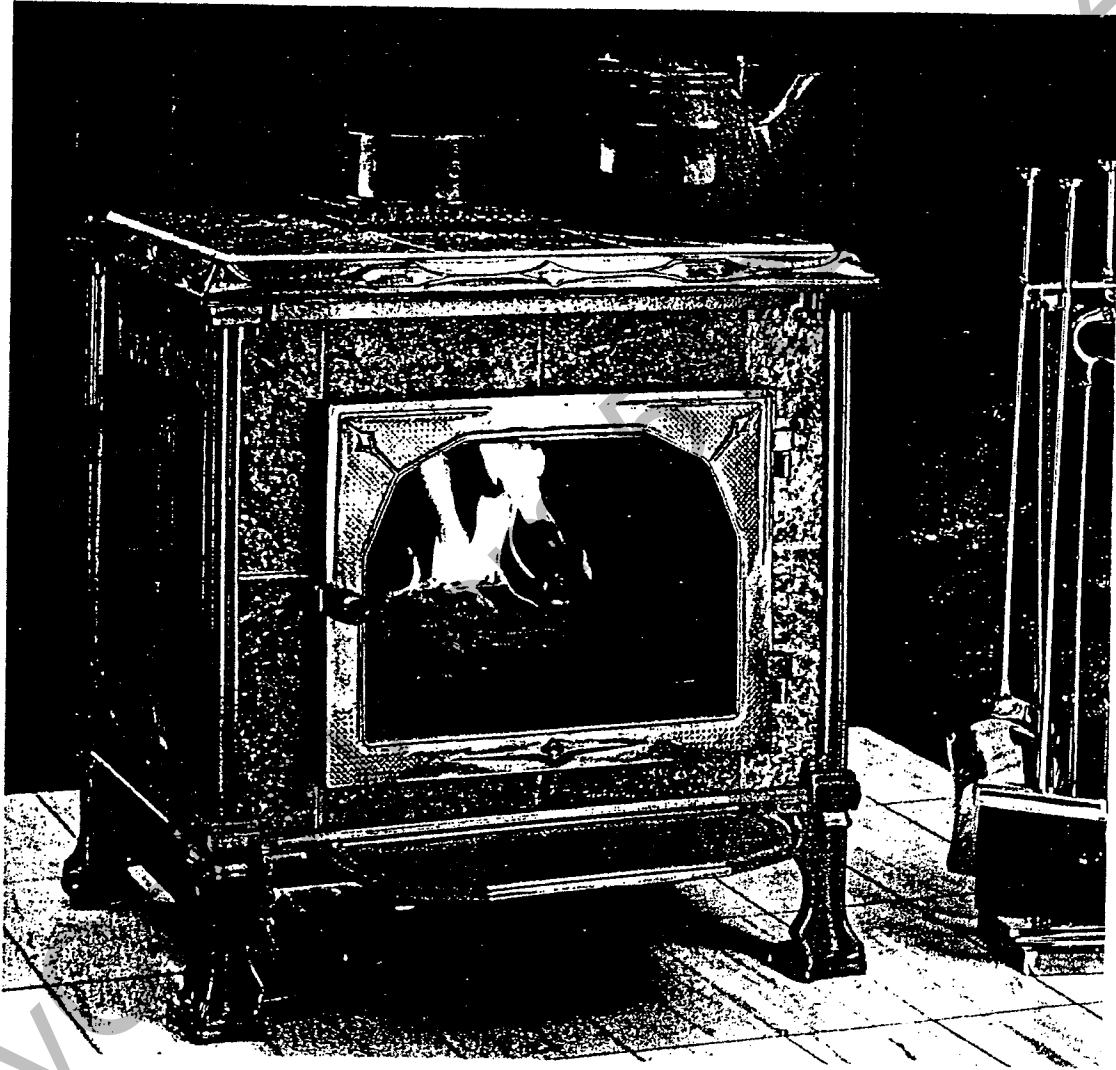

Owner's Manual

SAFETY NOTICE: IF THIS STOVE IS NOT PROPERLY INSTALLED, A HOUSE FIRE MAY RESULT. FOR YOUR SAFETY, FOLLOW THE INSTALLATION DIRECTIONS. CONTACT LOCAL BUILDING OR FIRE OFFICIALS ABOUT RESTRICTIONS AND INSTALLATION INSPECTION IN YOUR AREA.

Welcome to the HearthStone Family. You have made an investment in perhaps the finest solid fuel radiant/convection heater available today. To own a HearthStone Stove is to make a statement - a statement of your appreciation and understanding of a quality handcrafted product.

Please read this manual in its entirety. Its purpose is to familiarize you with your stove's safe installation, proper break-in, operation and maintenance. It contains information that will be useful to you now and in years to come, so keep it handy and refer to it as needed.

The performance of your stove depends on many variables that make your installation unique. The sections on operating procedure and general information, therefore, can only serve as useful guidelines rather than hard and fast rules. Should you have any questions, do not hesitate to contact the factory or your dealer for additional information. You have invested in a product whose warranty is accompanied by a pledge to provide you with assistance as long as you own your stove.

TABLE OF CONTENTS

	<u>PAGE</u>
I. INSTALLATION MATERIALS NEEDED FOR YOUR SAFETY.....	2
II. INSTALLATION.....	2
A. LOCATING YOUR STOVE.....	3
B. FLOOR PROTECTOR.....	4
C. VENTING SYSTEM.....	4
D. CHIMNEY CONNECTOR.....	4
E. CONNECTION TO A MASONRY CHIMNEY.....	5-6
F. CONNECTION TO A MASONRY FIREPLACE.....	6-7
G. CONNECTION TO A METAL PREFABRICATED CHIMNEY.....	7
III. OPERATING INSTRUCTIONS.....	8
A. CONTROLS AND FEATURES.....	8-9
B. YOUR CATALYTIC COMBUSTORS.....	10
C. BUILDING A FIRE.....	10-11
D. OVERFIRING CAUTION.....	12
E. DISPOSAL OF ASHES.....	12
IV. MAINTENANCE.....	12
A. MONITORING YOUR TEMPERATURES.....	12-13
B. CREOSOTE FORMATION AND NEED FOR REMOVAL.....	13
C. CATALYTIC COMBUSTORS.....	13-15
D. GLASS.....	16
E. GASKETS.....	16
F. STONE.....	17
G. CASTINGS.....	17
H. TOP VENT TO REAR VENT CONVERSION.....	17
V. OPERATION GUIDELINES.....	18
A. DO'S AND DO NOT'S.....	18
B. SAFETY GUIDELINES.....	18-19
C. PERIODIC CHECK LIST.....	19
D. EMERGENCY PROCEDURES.....	19
E. FUELWOOD INFORMATION.....	20
VI. TROUBLESHOOTING.....	20
A. YOUR HEATING NEEDS.....	20-21
B. TROUBLESHOOTING GUIDE.....	21-23
<u>IMPORTANT WARRANTY INFORMATION.....</u>	<u>24</u>
<u>HARVEST SPECIFICATIONS.....</u>	<u>25</u>

N.H.C., INC.
P.O. BOX 1069, LAMOILLE INDUSTRIAL PARK
MORRISVILLE, VT. 05661
CUSTOMER SERVICE DEPARTMENT: (802) 888-5232

This manual describes the installation and operation of the Hearthstone Harvest Catalytic Wood Stove. This stove meets E.P.A. Particulate Matter (smoke) Control Requirements for Catalytic Wood Heaters build on or after July 1, 1990. Under specific test conditions this heater has been shown to deliver heat at rates ranging from 8,800 to 28,000 BTU's per hour.

SAFETY NOTICE: IF THIS STOVE IS NOT PROPERLY INSTALLED, A HOUSE FIRE MAY RESULT. FOR YOUR SAFETY, FOLLOW THE INSTALLATION DIRECTIONS. CONTACT LOCAL BUILDING OR FIRE OFFICIALS ABOUT RESTRICTIONS AND INSTALLATION INSPECTION IN YOUR AREA.

I. INSTALLATION MATERIALS NEEDED FOR YOUR SAFETY

CHIMNEY CONNECTOR: The chimney connector joins the stove to the chimney. It should be 6" diameter 24 gauge minimum metal stovepipe.

THIMBLE: A manufactured or site-constructed device installed in combustible walls through which the chimney connector passes to the chimney. It is intended to keep walls from igniting.

CHIMNEY:

APPROVED MASONRY with at least 5/8" fire clay lining joined with refractory cement or other listed lining system suitable for use with wood stoves.

OR

PREFABRICATED 6" listed high temperature (tested to 2100°F) residential type and building heating appliance chimney. Components required by manufacturers for installation such as the chimney support base, firestop (as appropriate), attic insulation shield, insulated tee, etc. are necessary to assure a safe chimney installation. Use only components manufactured for the chimney.

FLOOR PROTECTOR: 3/8" minimum thickness non-combustible material.

AVOID FIRE: Maintain the designated clearance distance to combustibles. Insulation must not touch the chimney. There must be the designated air space clearance around the chimney. This air space around a chimney is necessary to allow natural heat removal from the area. Insulation in this space will cause a heat build-up which may ignite wood framing.

II. INSTALLATION

Before your Harvest can be installed, the rear heat shield must be positioned on the rear of the stove. The shield is attached to the brackets on the back of the chamber back. Slide the brackets into the slots cut into the shield. The lip of the shield should be positioned underneath the stove (to provide protection for the hearth).

NOTE: There are four tapped holes in the chamber back corners, and you have been provided with four bolts and four brackets. Bolt the brackets to the chamber back (tabs facing upward) before sliding them into the heat shield slots.

A. LOCATING YOUR STOVE

FIGURE 1

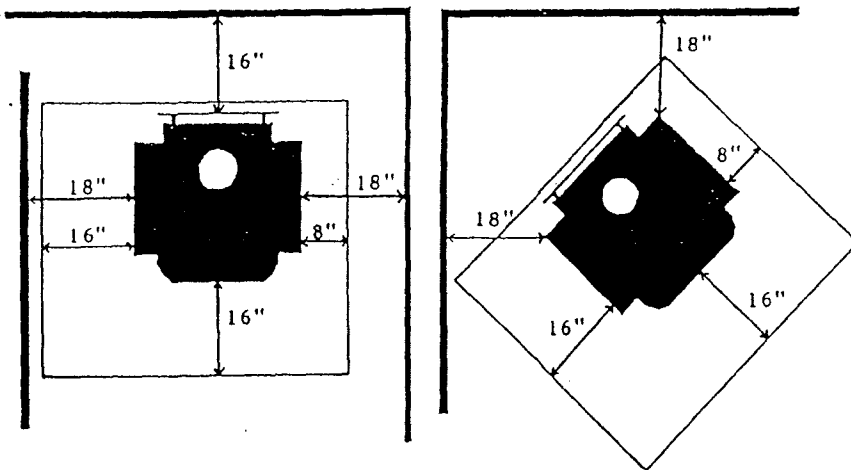

FREESTANDING MODE:

Back wall to heat shield	16"
Right side wall to stove	18"
Left side wall to stove	18"
Back wall to stovepipe OD	22"
Side wall to stovepipe OD	22"

CORNER INSTALLATION:

Rear left & right corners to side walls	18"
---	-----

HEARTH MODE:

Stove to top trim	15"
Stove to mantle	25"
Stove to side trim	10"
Hearth Extension in front of stove from legs	16"
Distance from the rear heat shield to the hearth opening should not exceed 4 3/4".	

FIGURE 2

HARVEST CLEARANCES TO COMBUSTIBLES HEARTH MOUNT (REAR VENT ONLY)

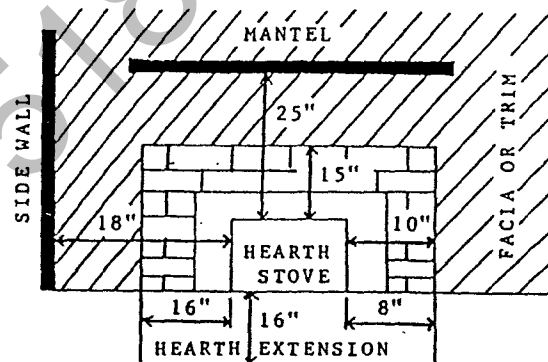

When locating your stove, consider safety, convenience, traffic flow, and the fact that the stove will need a chimney and chimney connector.

Your stove should be located away from doors and hallways in an open area to allow for necessary clearances. Review figures 1 and 2 for MINIMUM clearances.

Keep furniture, drapes, curtains, wood, paper, and other combustibles far away from the stove. Never install the stove in locations where gasoline, kerosene, charcoal lighter, or any other flammable liquids are used or stored.

Your Harvest's soapstone walls produce an even, radiant heat. Locate the stove centrally in your living area to allow the heat to travel naturally to distant rooms.

Do not locate your stove in the basement. The amount of radiant energy required to heat your basement walls is so great that most of the useable heat is absorbed by them and lost.

DO NOT INSTALL THIS STOVE IN A MOBLE HOME.

B. FLOOR PROTECTOR

The stove must be placed on a floor protector if the floor is wood or other combustible flooring. If carpeting is present, it must be removed. The floor protector must not be placed on carpet.

An acceptable floor protector is a 3/8" minimum thickness non-combustible material. The rear heat shield must be in place while the stove is in operation. The following clearances are the distance the hearth should extend beyond the body of the stove:

FRONT: 16" (beyond the ash lip)

LOADING DOOR SIDE: 16"

RIGHT SIDE: 8"

REAR: The hearth should cover the entire area beneath the catalysts and rear heat shield (approximately 8").

C. VENTING SYSTEM

The venting system consists of a chimney connector (usually a stovepipe) and a chimney. These get extremely hot during use. Temperatures inside the chimney may exceed 2000°F in the event of a creosote fire. To protect against the possibility of a house fire, the chimney and stovepipe must be properly installed and maintained. A thimble must be used when a connection is made through a combustible wall to the chimney. A chimney support package must be used when a connection is made through the ceiling to a prefabricated chimney. These accessories are absolutely necessary to provide safe clearances to combustible wall and ceiling material.

This stove may be connected to a lined masonry chimney or a listed high temperature prefabricated residential type building heating appliance chimney. Do not connect it to a chimney serving another appliance. To do so will affect the safe operation of both appliances.

D. CHIMNEY CONNECTOR

The chimney connector must be 6" diameter 24 gauge stovepipe. Do not use aluminum or galvanized steel. They cannot properly withstand the extreme temperatures of a wood fire. Do not use stovepipe as a chimney. You must connect your stove to a chimney comparable to those recommended in this manual.

Stovepipe sections must be attached to the stove and to each other with the crimped end toward the stove. This allows creosote to run into the stove and not onto the outside of the pipe. All joints should be secured with three sheet metal screws.

Otherwise, in the event of a creosote fire, the stovepipe may vibrate apart. Holes pre-drilled in the Harvest's flue collar accept 1/8" X 1/2" sheet metal screws.

Additional stovepipe accessories (draw-bands, slip-joints, clean-out tees) greatly simplify the connection of stovepipe to chimney, make inspection easier, and let you dismantle the stovepipe without moving the stove. Because of the air control design of the Harvest, a stovepipe damper is not necessary.

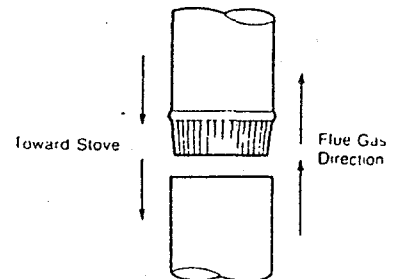

For proper operation, the stovepipe should be as short as possible. Avoid too many elbows. Horizontal lengths of stovepipe should have an upward slope from the stove of at least 1/4" per foot. Maintain 22" clearance between the stovepipe and the wall and 18" to the ceiling.

E. CONNECTION TO A MASONRY CHIMNEY

CHIMNEY: Should the stove be connected to a masonry chimney, the chimney should be examined for cracks, loose mortar, other signs of deterioration, and blockage. The stove should not be installed until it is determined that the chimney is safe for use. Since an oversized flue contributes to the accumulation of creosote, the size of the flue should be checked to determine that it is not too large for the stove. For this stove, the flue should be no larger than 8" X 8" or 6" in diameter. The chimney should also be checked to assure it meets the minimum standards of the National Fire Protection Association (NFPA) Standard 211. Following is a list of the more critical minimum requirements for a properly constructed chimney.

The masonry wall of the chimney, of brick or modular block, must be a minimum of 4" thick. A rubble or stone wall must be at least 12" thick.

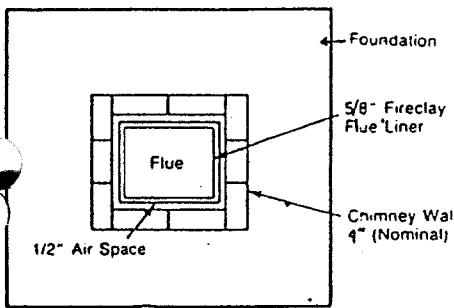

The chimney must have a fire clay flue liner (or equivalent) with a minimum thickness of 5/8" and must be installed with refractory mortar. There must be at least 1/2" air space between the flue liner and the chimney wall. An equivalent liner must be a listed chimney liner system or other approved material.

A chimney inside the house must have at least 2" of clearance to the combustible structure. A chimney outside the house must have at least 1" clearance to the combustible structure. Fire stops must be installed at the spaces where the chimney passes through floors and/or ceiling.

Remember that insulation must not contact the chimney. There must be air space around the chimney. Insulation must be 2" or more from the chimney.

A chimney must be the required height above the roof or other obstruction for proper draft. The requirement is that the chimney must be at least 3 feet higher than the highest point where it passes through the roof and at least 2 feet higher than the highest part of the roof or structure that is within 10 feet of the chimney, measured horizontally.

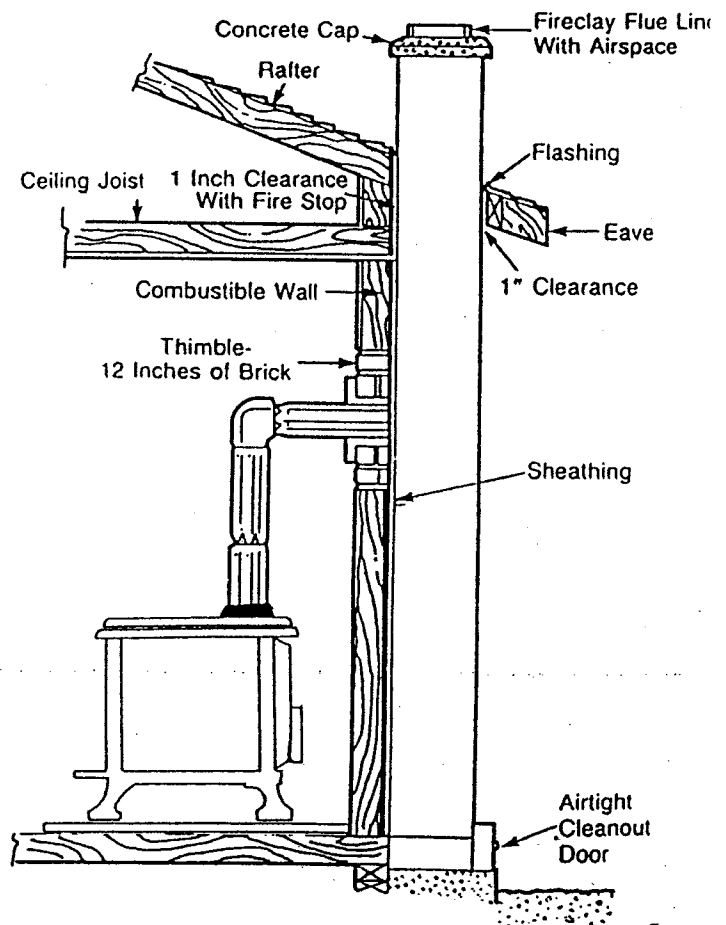

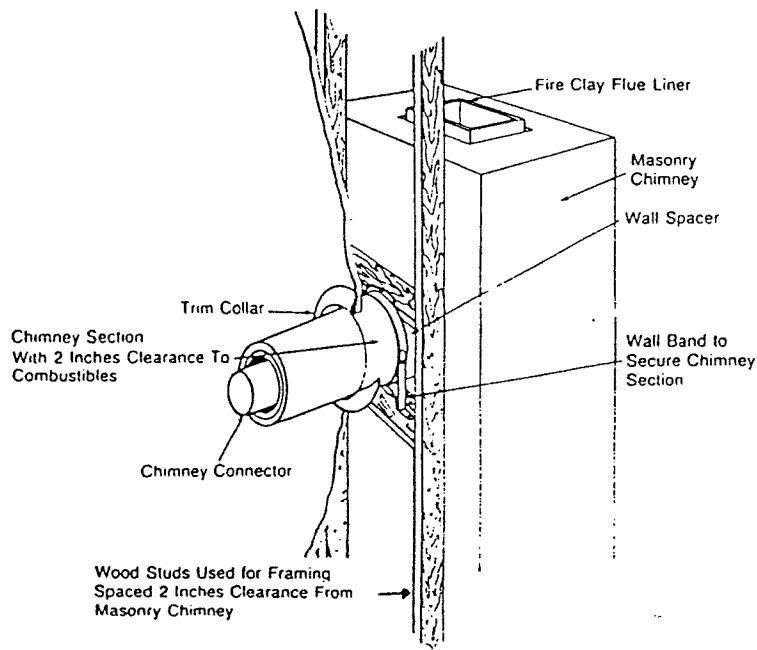

THIMBLE: A thimble must be used when the connection from the stove is made through a combustible wall to a masonry chimney. There are several methods to use for connection through a combustible wall. Local building authorities may be consulted or NFPA 211 may be used for referencing methods of chimney connection.

Also, listed prefabricated metal thimbles can be bought for use with wood stoves. The manufacturer's installation instructions must be strictly followed to assure the safety of the system. Be sure to maintain the designated clearance to combustible materials.

F. CONNECTION TO A MASONRY FIREPLACE

There are several kits available to connect the stove to a masonry fireplace. Look for a listed kit. The kit is an adapter which is installed at the location of the fireplace damper. The existing damper may have to be removed to allow installation of the kit. The key points of this type of stove connection are that the connector pipe must extend up the chimney above where the fire clay liner starts, and the areas of the kit installation and connector penetration should fit tightly and be sealed with high temperature furnace cement unless the kit's instructions state otherwise. Retaining a 6" flue which is tightly fitting aids the proper draw of the chimney.

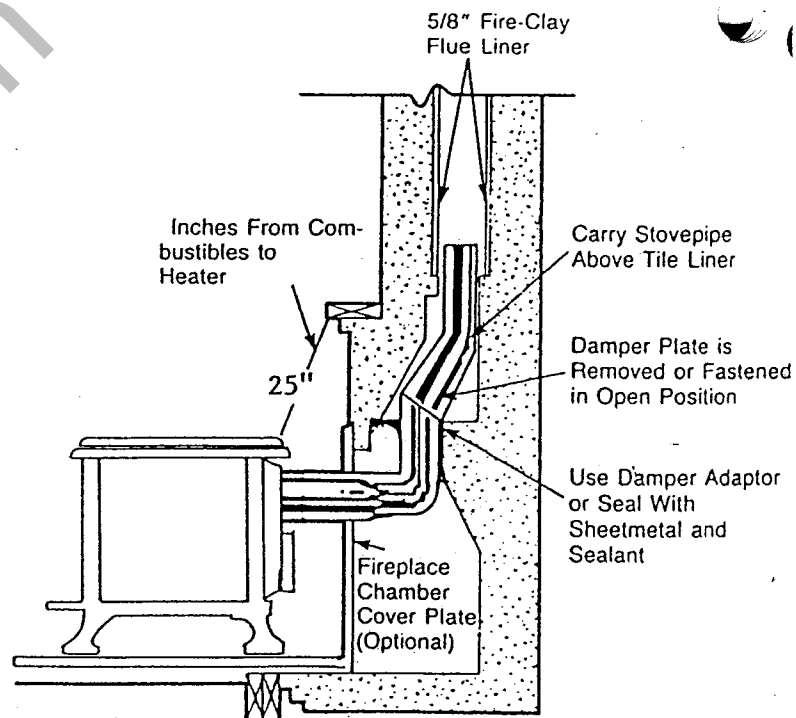

Install an attic insulation shield to maintain the specified clearance to insulation. Insulation in this air space will cause a heat buildup which may ignite the ceiling joists.

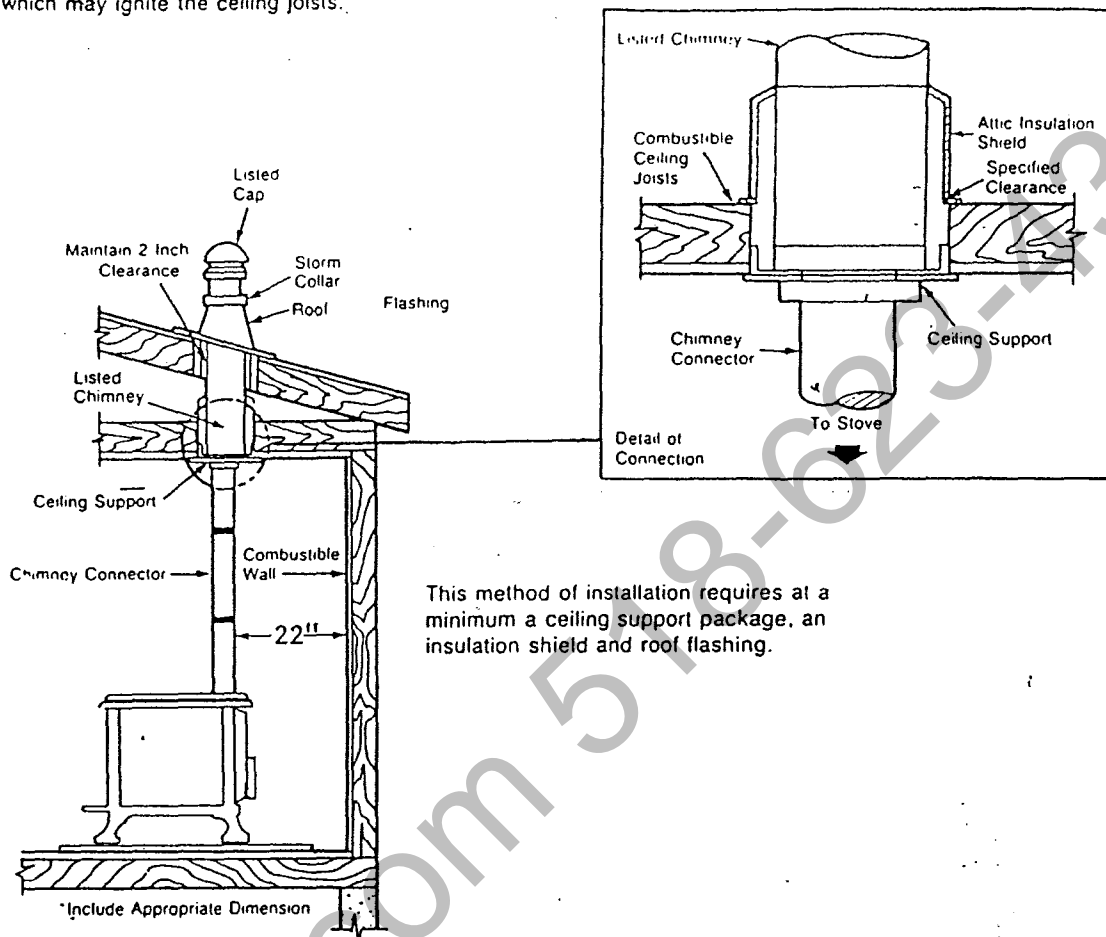

This method of installation requires at a minimum a ceiling support package, an insulation shield and roof flashing.

G. CONNECTION TO A METAL PREFABRICATED CHIMNEY

When a metal prefabricated chimney is used, the manufacturer's installation instructions must be followed precisely. Choose only Class A 103 H.T., solid insulation type chimneys. You must also purchase (from the same manufacturer) and install the ceiling support package or wall pass-through and "T" section package, firestops (when needed), insulation shield, roof flashing, chimney cap, etc. Maintain the proper clearance to the structure as recommended by the manufacturer. This clearance is usually a minimum of 2", although it may vary by manufacturer or for certain components.

There are basically two methods of metal chimney installation. One method is to install the chimney inside the residence through the ceiling and roof. This is illustrated above. The other method is to install an exterior chimney that runs up the outside of the residence. The interior chimney is recommended. The exterior chimney walls may cool quicker which reduces the draft and increases creosote accumulation. The height requirements are the same as for a masonry chimney.

III. OPERATING INSTRUCTIONS

A. CONTROLS AND FEATURES

BYPASS DAMPER: The damper is located in the upper rear of the firebox and is operated on the upper left side of the stove with the detachable T-handle. Turn it counter-clockwise to open the damper and clockwise to close it. When the damper is open, it provides a direct smoke path up the flue which bypasses the catalytic combustors. The damper should be opened only under the following circumstances:

1. When starting the stove.
2. For 5 to 15 minutes after reloading with fuel.
3. For 30 seconds before opening either door to prevent smoke spillage or to "boost" the draft when necessary.

PRIMARY AIR: Located in the rear, the primary air intake is to the right and at the bottom of the stove. The rate of burn will be determined in part by how much air is allowed to enter through the primary air intake.

THROTTLE CONTROL: Installed in the flue collar is a supplemental draft control which allows an extended burn time, if desired. The throttle should remain open while operating the stove with the bypass damper and the primary air control open.

AIR WASH CONTROL: This slide air control is located above the front door. Normally, it should remain in the open position (fully right) to admit a uniform flow of air for maintaining glass cleanliness. By adjusting this slide to the extreme left, air entry will be at a minimum. This may be desired to achieve long burn time, or in the event of a chimney fire.

SECONDARY AIR INLET: Air for the catalytic combustors enters through a port in the rear of the stove. The amount of air is metered automatically by a bi-metallic element. No adjustment is necessary.

DYNAMIC GRATE: Centrally positioned on the bottom of the stove floor is the sliding or dynamic grate with a hinged handle. The oblong holes in this grate do not coincide with those in the stationary grate when the side door is fully closed. This design helps minimize under-fire air which is deleterious to clean burning performance as well as the life of the stove. Ashes may be raked by opening the side door and sliding the grate toward you. By doing this, the holes in the upper and lower grates coincide, thereby permitting the ashes to be raked through these grates into the ash pan. Do not shake the grate back and forth to perform this task; use the proper fire-tending tool.

Closing the grate is accomplished by reversing this process or by simply closing the side door. Should an obstacle wedge itself between the holes of the sliding and stationary grates while a fire is present in the stove, shake the grate back and forth a few times to clear the obstacle. If this is unsuccessful, then the hinged portion of the handle must be lifted through the side or front door with a poker or other fire-tending tool. Then, the door can be closed. When the stove is cool, the obstructions should be removed from the grate.

REVERSIBLE FLUE COLLAR AND COVER PLATE: The reversible flue collar and cover plate provide a system for configuring the stove as a top or rear vented stove. This modification can be performed in the field. This stove must be adapted to the rear vent mode when connecting to a masonry fireplace. (Refer to the MAINTENANCE section for instructions.)

FAMILIARIZE YOURSELF WITH THESE CONTROLS AND FEATURES
BEFORE YOUR FIRST FIRE

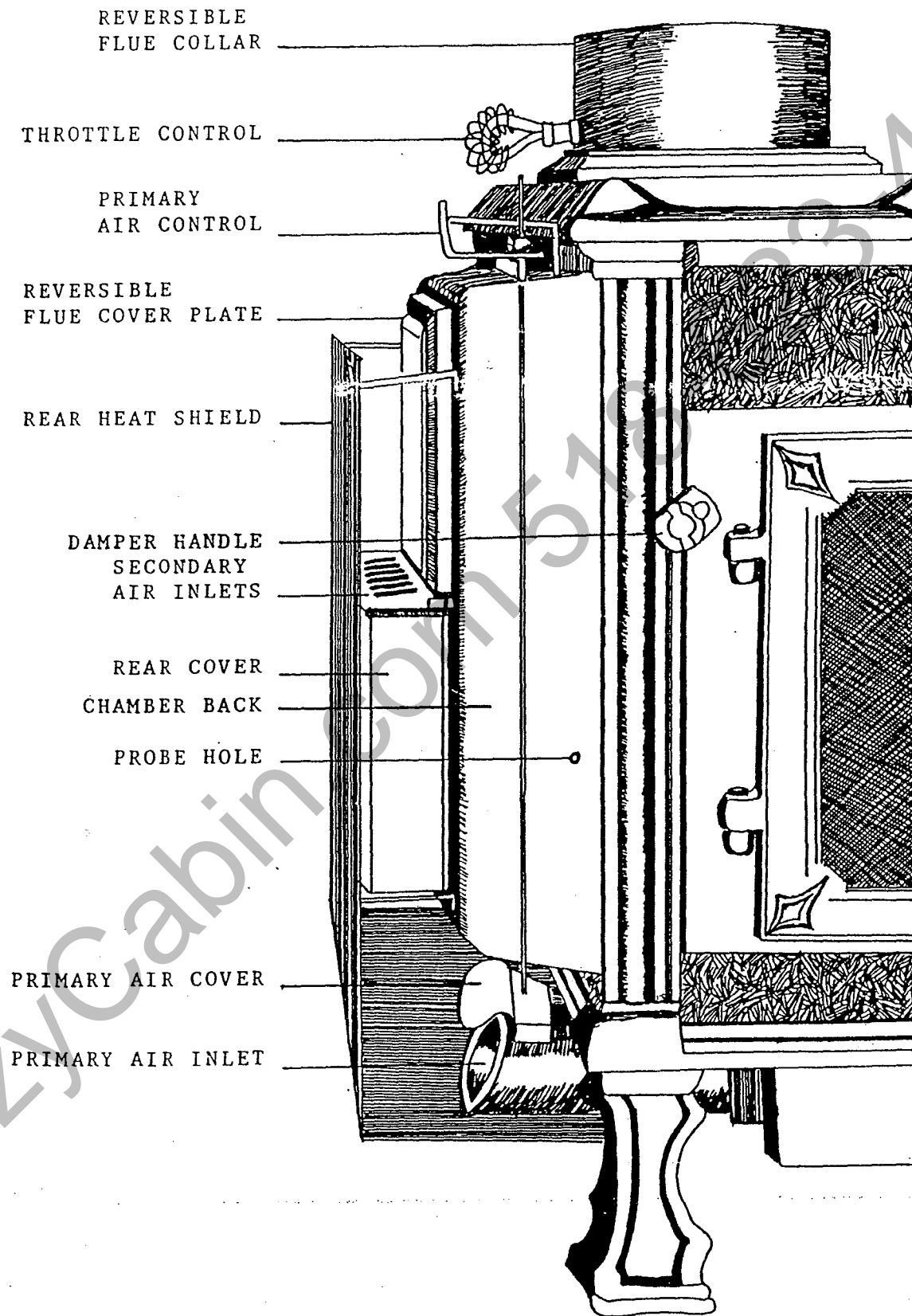

B. YOUR CATALYTIC COMBUSTORS

The Harvest is equipped with catalytic combustors. They are located in the lower rear space between the inner and outer cast iron panels. The special interior design insures that the greatest possible volume of smoke will pass through the combustors.

The goal of the catalyst is to increase the overall efficiency of your stove. By-products of combustion in the firebox are burned in the combustors. This greatly reduces the rate of creosote accumulation; it does not, however, eliminate creosote accumulation entirely.

Using proper fuel is vital to gain the full benefit of the catalytic combustors. Whenever possible, seasoned hardwood should be used. Green wood can dramatically reduce the efficiency as well as the heat output of the stove. **THE FOLLOWING MATERIALS SHOULD NEVER BE USED AS FUEL IN A STOVE EQUIPPED WITH CATALYTIC COMBUSTORS:** Artificial Logs, Coal, Household Trash, Chemical Fire Starters or Chimney Cleaners, Garbage, Treated or Painted Wood, Colored or Glossy Paper. Black and white newspaper may be used to start a fire.

The best place to monitor the stove performance is at the combustor. A probe-type thermometer should be purchased to read temperatures at the combustors. We have provided access to the combustors by a thermocouple (probe) hole on the left side of the chamber back. Remove this plug to access the hole. Monitoring combustor temperatures will help insure that you are getting the full benefit of your Harvest.

C. BUILDING A FIRE

BREAK-IN PROCEDURE: It is imperative that your stove be broken in very slowly. Cast iron must be "seasoned"; overfiring a new stove may cause castings to crack or may damage other stove parts. Moisture in the soapstone must be driven out slowly to minimize the "shock" to the stove of its first exposure to high firebox temperatures. Also, the asbestos-free furnace cement must be cured slowly to insure adequate sealing and bond. The bottom layer of soapstones in your firebox are intended to prevent thermal stress and should remain in place in the firebox at all times.

TO BUILD YOUR FIRST FIRE:

1. Open the bypass damper and air controls.
2. Place five or six double sheets of tightly twisted newspaper in the center of the firebox.
3. Arrange kindling in a criss-cross pattern over the newspaper. (Kindling should be approximately ten pieces, 1/2" in diameter and 10" to 18" long.)
4. To get the draft started, light the paper under the kindling.
5. Leave the front door slightly ajar until the kindling has started to burn and draft begins to pull.
6. **KEEP A WATCHFUL EYE ON YOUR STOVE** to maintain a steady, low-heat fire. Your first and subsequent break-in fires should make the stove warm but not hot to the touch. (At the most, a few small chunks of wood should be added to the fire to reach these safe break-in temperatures.)

7. Once these temperatures have been achieved, close all air controls and allow the fire to die out completely.
8. Let the stove return to room temperature.

Your first three break-in fires should be built and maintained accordingly. Your patience will be rewarded by a properly seasoned stove.

Do not be alarmed by a white foamy substance which may appear on the rear cover of your stove after your first few fires. This is the adhesive which holds the insulation onto the rear cover. The excess may be scraped off with a single edged razor.

Because of the cool flue gas temperatures present during the break-in, creosote may build up quickly. We recommend a visual inspection (and cleaning if necessary) of your stovepipe and chimney and combustors once the break-in procedure is completed.

NORMAL OPERATION: If your stove is not to be used continuously, follow the break-in procedure at least once to minimize the stress of a hot fire on a cold stove.

TO BUILD A FIRE FOR EVERYDAY USE:

1. Open the bypass damper and air controls.
2. Place five or six double sheets of tightly twisted newspaper in the center of the firebox.
3. Arrange kindling in a criss-cross pattern over the newspaper.
4. To get the draft started, light the paper under the kindling.
5. Leave the front door slightly ajar until kindling has started to burn and draft begins to pull.
6. Add the logs, small at first to build the fire up, and let the fire burn briskly for 10 to 20 minutes.
7. Once the fire is burning well, close the bypass damper and use the air controls to achieve the desired burn rate.
8. When reloading, once again open all air intakes and the bypass damper. It is advised to wait at least three minutes before opening the loading door. Reloading on a bed of hot, red coals reduces smoking time and will bring fresh fuel up to a high temperature rapidly.
9. Reload and close the door.
10. Keep the bypass damper and air controls open 5 to 15 minutes or until the fire is fully established again.
11. Close the bypass damper and use the air controls to achieve the desired burn rate.

NOTE: Some days a draft isn't easily established. Seasonal factors or a cold chimney may be the problem. Try starting the fire by using small kindling and fuel to obtain a quick, hot fire. Tend the fire frequently with small fuel until the chimney is hot and the draft is well established.

BURN RATE: For a **HIGH BURN**, open fully the primary air inlet, front door airwash, and throttle. If the stove is overfiring, the air controls should be closed to reduce the temperatures. By closing the primary air inlet almost all the way, you'll have a **MEDIUM BURN**. A **LOW BURN** is achieved when the primary air inlet and throttle control are completely closed. In the case of a chimney fire, close all air controls including the air wash control.

D. OVERFIRING CAUTION

Overfiring means operating your stove at excessively high temperatures for extended periods of time. Because it can cause damage to the stove, it should be carefully avoided. The surest indication of overfiring is when the stove creaks and glows and when enameled surfaces bubble. In an overfire situation, all air controls should be closed to reduce temperatures.

Evidence of overfiring is warping and/or failure of internal parts, disintegrated combustors, discolored external cast iron, or damaged enamel. Blistering or bubbling of enameled parts is caused when the temperature of the enamel is in excess of 900°F.

ANY OF THESE SYMPTOMS OF OVERFIRING WILL VOID YOUR WARRANTY!!

E. DISPOSAL OF ASHES

Ashes should be placed in a metal container with a tight fitting lid. The closed container of ashes should be placed on a noncombustible floor or the ground, well away from all combustible materials, pending disposal. Ashes should be retained in the closed container until all cinders have thoroughly cooled.

Ashes should NEVER be placed in wooden or plastic containers, or in paper or plastic bags, no matter how long the fire has been out. Coals have been known to stay hot for several days when embedded in ashes.

IV. MAINTENANCE

A. MONITORING YOUR TEMPERATURES

By reading the temperature of your stove at various locations, operation and troubleshooting are simplified. We recommend an electronic monitor with a hi-temp 9" thermocouple for installation at the combustors and a standard 4" thermocouple for installation in the stovepipe (approx. 12" from the flue collar).

If you monitor the combustor temperatures, you can determine if the stove is overfiring or supplying adequate heat, or if the combustors are active or have failed. Temperatures in the range of 350°F to 1600°F indicate that the stove is operating properly and is supplying adequate heat. This is also the range of a normal operating combustor. Temperatures in excess of 1600°F indicate an overfire situation; keep the combustors under 1600°F. (If you cannot keep the temperatures of the combustors consistently under 1600°F, consult the Troubleshooting Guide.) Consistently low temperatures indicate a problem. It is possible that the combustors have failed, but the Troubleshooting Guide will help you evaluate the situation properly.

Temperature guidelines of the stack are as follows:
0°F to 420°F LOW BURN- Typical temperatures of a stack at the start up of a fire.
420°F to 750°F NORMAL OPERATION- By maintaining these temperatures, you can be sure to avoid an overfire situation.
750°F + OVERFIRING- Close all air controls to reduce temperatures.

B. CREOSOTE FORMATION AND NEED FOR REMOVAL

When wood is burned, it produces tar, water vapor, and other organic vapors which combine to form creosote. The creosote vapors condense in the relatively cool chimney flue of a newly started fire.

As a result, creosote residue accumulates on the flue lining. When ignited, this creosote makes an extremely hot fire which may damage the chimney or even destroy the house.

The chimney connector and chimney should be inspected at least twice monthly during the heating season to determine if a creosote buildup has occurred. If creosote has accumulated (greater than 1/4"), it should be removed to reduce the risk of a chimney fire.

The system is inspected at the stove connection and at the chimney top. Cooler surfaces tend to build creosote deposits quicker, so it is important to check the chimney from the top as well as from the bottom.

The creosote should be removed with a brush specifically designed for the type of chimney in use. A chimney sweep can perform this service. It is also recommended that before each heating season the entire system be professionally inspected, and cleaned and repaired if necessary.

C. CATALYTIC COMBUSTORS

THIS WOOD HEATER CONTAINS CATALYTIC COMBUSTORS, WHICH NEED PERIODIC INSPECTION AND REPLACEMENT FOR PROPER OPERATION. IT IS AGAINST THE LAW TO OPERATE THIS WOOD HEATER IN A MANNER INCONSISTENT WITH THESE OPERATING INSTRUCTIONS, OR IF THE COMBUSTORS ARE DEACTIVATED OR REMOVED.

INSPECTION: Visually inspect your combustors when your stove is cold at least three times during the heating season to determine if physical degradation has occurred. The Harvest's unique design allows for viewing of the combustors without removing them. The combustors can be damaged by excessive handling and warranty will not be honored for damage from handling. Removal is only necessary when decreased performance of the stove is evident.

The Catalytic Cell has been designed to provide uniform temperatures throughout the catalytic combustors, thereby minimizing the likelihood of cracking. It is important to point out that if cracks are observed in the ceramic, it does not mean that there is a problem. Since the ceramic acts only as a mechanical support for the catalyst (a chemical coating on the ceramic surface which stimulates combustion without being consumed itself), it may have cracks while remaining perfectly operational.

To remove the combustors:

1. Remove the rear heat shield.
2. Before removing the rear cover of the catalytic cell, place a nonflammable container on the hearth to catch any ashes that may fall when the cover is removed.
3. Remove the rear cover by removing the nuts which secure the cover to the chamber back.
4. Empty any ashes in the cover into the nonflammable container.
5. Inspect the combustors to see if they are still there.
6. If the combustors are there, then this portion of the inspection is over.
7. If only a portion of the combustors are there, or if they are completely gone, replacement is indicated.

NOTE: It is also necessary to determine whether or not fly ash is present on the combustor's surface. Ash can be removed with a soft fiber brush, such as a paint brush. Never clean the internal chambers of the combustors with any kind of instrument. Burning the proper fuels will keep it clean inside.

8. Replace the cover by reversing procedure. Tighten the nuts only until they are snug. Over-tightening the cover will damage it.
9. Replace the rear heat shield.

REPLACEMENT: The combustors have been designed for many thousands of hours of use. When any of the following symptoms occur, it is time to replace the combustors.

1. If the stove operation becomes chronically sluggish. Temporarily, this could be due to weather conditions.
2. Heavy creosote formation is evident. Be sure to inspect regularly.
3. More smoke than normal emitted from the chimney.
4. Catalytic combustors' temperature lower than usual (when monitoring is being practiced).

To replace the combustors:

1. Remove the rear heat shield and rear cover as outlined in the preceding instructions on inspection of combustors.
2. The combustor tray may be removed from the stove as a unit by simply pulling out the tray that holds them in position. You may need to pry the tray loose if it does not release easily.
3. Remove the tray cover to access the combustors.
4. Remove the combustors and return them to the combustor manufacturer for warranty consideration. Reference your combustor warranty card you received with your stove for the manufacturer name, address, and telephone number.
5. Before closing the cover, remove ashes from the smoke passages of the catalytic cell beneath the tray that holds the combustors.
6. DO NOT OPERATE THE STOVE WITHOUT THE COMBUSTORS.
7. Upon receipt of your new combustors, follow the illustrations to place the new combustors into the tray. Reverse procedure to replace the tray, rear cover, and rear heat shield. Remember not to over-tighten the rear cover nuts.

COMBUSTOR TRAY INSTALLED IN THE CATALYTIC CELL

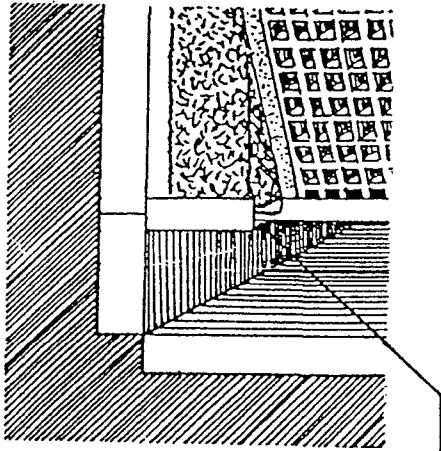

WEDGE HERE WITH A SCREWDRIVER—BOTH SIDES

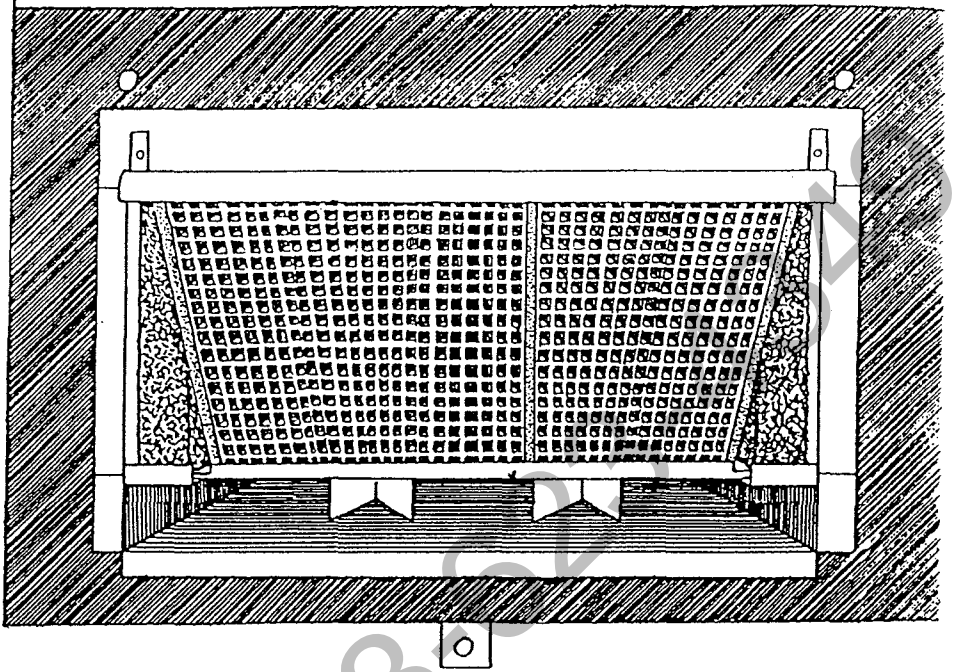

COMBUSTOR AND GASKET PLACEMENT IN THE COMBUSTOR TRAY

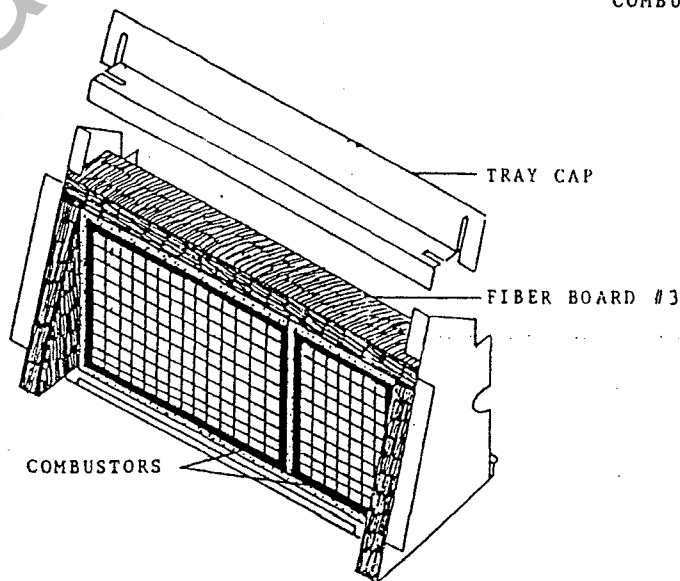
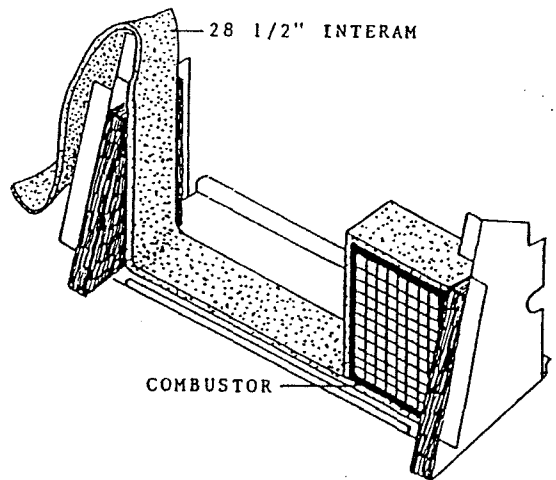
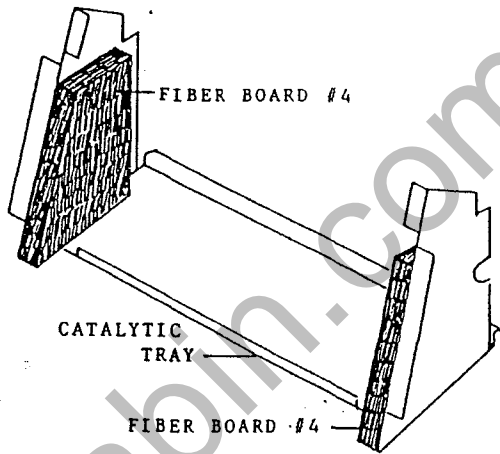

D. GLASS

The glass in your Harvest is a thermal, shock-resistant glass, made specifically for wood stoves, and should not be substituted. In the event of breakage, it should be replaced immediately. Contact our Customer Service Department or your Dealer for replacement glass which is accompanied with instructions and everything needed for the repair.

The procedure for glass and glass gasket replacement is as follows:

1. Remove the door by lifting it straight up off the hinges with the rivets remaining in the door.
2. Place it face down on a flat, smooth surface.
3. Remove the eight window frame screws to separate the window frame from the door.
4. Carefully lift the glass from the door.
5. To replace the glass, place the new pre-gasketed glass onto the door with the cushion of gasket facing down towards the door.
6. To replace only the gasket, remove the old gasket from the glass. Apply the new gasket as illustrated to form a cushion on one side of the glass. Place the glass onto the door with the cushion of gasket facing down towards the door.
7. Replace and screw the window frame back to the door.
8. Replace the door.

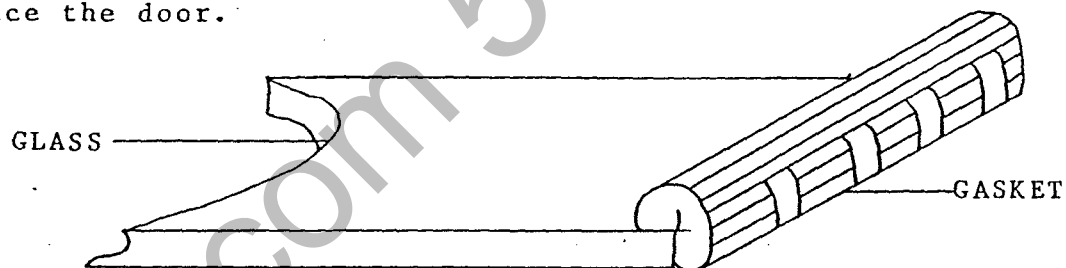

E. GASKETS

Normally, gasket material should be replaced every two to three seasons, depending on stove use. Also, if the door seals are loose, a new gasket will assure a tight seal. Contact our Customer Service Department or your Dealer for a gasket kit which includes instructions and gaskets for your three doors and the glass.

The procedure for replacing gaskets on the glass is reviewed in Section D. Glass. To replace gaskets in the doors, first remove old gaskets with a utility or putty knife. Clean all gasket channels with a wire brush. Apply gasket cement to the channels and push new gaskets into them (without stretching). The door should be shut immediately to assure a positive seal.

We use the following gaskets:

GLASS:	3/4" Wide, Adhesive Backed, Black Tape	Qty.- 42"
FRONT DOOR:	1/4" Diameter, Low Density, Black Tube	Qty.- 54"
SIDE DOOR:	1/2" Diameter, Low Density, Black Tube	Qty.- 42"
ASH DOOR:	3/8" Diameter, Low Density, Black Tube	Qty.- 22.5"

F. STONE

Often, with use, subtle earth tones of brown, red, and yellow appear on the soapstone. This is a natural reaction in the soapstone. Occasional cleaning is all that should be necessary to maintain your Harvest's beauty. Care must be taken not to scratch or chip the stone. Clean the polished stones with water and any non-abrasive cleaner and a soft cloth. The natural finishes require a light sanding with fine sandpaper (200-220 grit). Wipe dust from the stone with a clean cloth.

G. CASTINGS

Exterior cast iron parts are painted with black, high-temperature stove paint. Use this type of paint to regain the cast iron's original appearance. When using a damp sponge to wipe clean, dry the iron thoroughly to prevent rusting.

The enamel castings can be cleaned with a standard glass cleaner. With time and use, a very fine subtle network of crazed lines may appear seemingly beneath the surface of the enamel. Crazing is a natural predictable process and does not represent a flaw.

H. TOP TO REAR VENT CONVERSION

The stove must be vented from the rear for installation into a masonry fireplace. The procedure for converting the stove from the top to the rear vent is as follows:

1. If the stove has been in use, work on a cold stove and disconnect the stovepipe.
2. The throttle control is removed to provide access to the retaining hardware. Pull it out.
3. Remove the rear heat shield.
4. The flue collar is cemented into place to prevent leakage. The cement seal can be broken with a hammer and wedge or loosened by soaking in water with a towel.
5. Reach through the front door and remove the two 1/4" nuts that hold the flue collar to the top casting. Use a 7/16" wrench.
6. Remove the flue collar by lifting it straight up and off the stove. Remove and retain the 1/4" threaded rods from the collar.
7. Reach through the top or through the opened bypass damper and remove the two 1/4" bolts in the reversible cover plate.
8. Remove the cover plate and save the bolts.
9. Check the gaskets on the collar and cover plate. Replacement is required if they are worn. (The collar and cover plate each use 35" of 1/4" diameter, low density, black tube type gasket. Be sure the gasket completely fills the gasket channel.)
10. Position the flue collar on the back of the stove.
11. Re-attach the bolts (used for the cover plate) to the collar. The Hearthstone logo faces downward.
12. Securely attach the threaded rods to the cover plate, and position it on the top of the stove (logo facing upward).
13. Snug the rods with the nuts. Do not over-torque these nuts. Do not apply excessive force to the top stones.
14. Replace the throttle control and rear heat shield.

V. OPERATION GUIDELINES

A. DO'S AND DO NOT'S

DO:

- Read and understand this Owner's Manual thoroughly before installing this stove.
- Install the stove according to N.H.C.'s recommendations.
- Burn natural wood only. Higher efficiencies and lower emissions generally result when burning air dried, seasoned hardwoods, as compared to green or freshly cut hardwoods.
- Install this appliance with the proper sized chimney.
- Maintain all door gaskets in good condition.
- For proper operation of the stove, the chimney must provide a good draft. Adequate draft is 0.05 to 0.09 inches of Water Column.
- Follow recommended break-in procedure as outlined in this manual.

DO NOT:

- Modify this product in any way. Doing so will compromise your safety and the particulate emissions which will VOID your warranty.
- Expect the stove to heat more than 50% of the recommended volume if installed in a basement or in any area with a large portion of uninsulated masonry walls.
- Burn kiln dried, painted or treated wood, solvents, trash, plywood, colored or glossy paper, artificial logs, cardboard, coal, garbage or driftwood. Burning these materials will shorten the life of the combustors.
- Use chemical fire starters or chimney cleaners as these materials will also shorten the life of the combustors.
- Burn the stove with the ash grates open or with improperly sealed doors. Overfiring may cause flame impingement on the combustors, which could cause early failure. Burning coal, cardboard, or loose paper can produce soot or large flakes of char or fly ash that can coat the combustors causing smoke spillage into the room and render the combustors inactive.
- Fail to inspect the chimney, chimney connector, and combustors as recommended.
- Ignore a sudden change in performance of the stove. The Troubleshooting Section of this manual will help you determine possible causes and solutions to any problem.

B. SAFETY GUIDELINES

1. Always keep combustible items (furniture, drapes, clothing, etc.) a minimum of 36" from the stove.
2. Do not overfire your stove.
3. Install a smoke alarm.
4. Keep a fire extinguisher handy. We recommend the type rated ABC.

5. Dispose of ashes properly.
6. NEVER use gasoline type fuel, kerosene, charcoal lighter fluid or similar liquids or solid fire starters to start or invigorate a fire. Keep all such materials away from the stove.
7. Keep children and pets away from the stove.
8. NEVER put articles of clothing or candles on a hot stove.
9. Do not connect the stove to a flue that is serving another appliance.
10. Inspect your chimney, chimney connector, and combustors regularly.
11. Clean your system when it is needed.

C. PERIODIC CHECKLIST

EVERY DAY:

- Empty ashes from the firebox and ash pan.

EVERY TWO WEEKS:

- Visually inspect chimney connector and chimney for creosote; clean accordingly.

EVERY EIGHT WEEKS:

- Check door seals using the "dollar bill test". When the fire is out, shut the door on a dollar bill. If the bill pulls out easily, the door isn't sealed properly. Change the gaskets.
- Inspect your combustors.

AT SEASON'S END:

- Dismantle chimney connector and clean thoroughly; replace any pieces that show signs of rust or deterioration.
- Inspect and, if necessary, clean your chimney.
- Thoroughly clean out the inside of the stove; inspect for signs of deterioration.
- Inspect gasket material in all doors and replace if worn, frayed, cracked or extremely hard.
- Repaint exterior black castings, if necessary.
- Inspect your combustors.

D. EMERGENCY PROCEDURES

In the event of a stovepipe or chimney fire:

1. Close all air intake systems, bypass damper and throttle control.
2. Keep all doors shut.
3. Call the Fire Department
4. Keep an eye on the stove, stovepipe, and chimney.

Once the chimney fire has expired, continue to keep all air inlets closed and let the fire in the stove die out completely. The stove should not be fired again until the stove, stovepipe, combustors, and chimney are all thoroughly inspected for any sign of damage. Damage must be corrected before resuming use of your stove.

FIRE DEPARTMENT TELEPHONE NUMBER: _____

E. FUELWOOD INFORMATION

The quality of your fuelwood is an important variable which determines both heat output and duration of burn. Softwoods generally burn hotter and faster, while hardwoods burn longer and produce more coals. The density of the wood is the critical factor to consider when either purchasing wood or assessing your stove's performance. For your reference, we have provided a list of wood species and their relative BTU content.

HIGH: Ash, Black Birch, Hickory, Hophorbeam, Locust, White Oak,
Black Beech

MEDIUM HIGH: White Ash, Beech, Yellow Birch, Sugar Maple, Red Oak

MEDIUM LOW: Black ash, White Birch, Grey Birch, Elm, Norway Pine,
Pitch Pine, Black Cherry, Soft Maple, Tamarack

LOW: White Pine, White Cedar, Balsam Fir, Spruce, Aspen, Basswood,
Butternut, Hemlock

Moisture content also plays a key role in the performance of your stove. Wood that is freshly cut from a living tree (green wood) has a great deal of moisture in it. To properly season green wood, it should be split and stacked and allowed to air dry for a period of six months to one year. Ideally, it should be stacked on skids or blocks to keep it off the ground, and only the top should be covered. Plastic or tarps that cover the sides of the woodpile trap moisture and prevent the wood from drying. As for stacking, an old Vermonter said, "The spaces between the logs should be large enough for a mouse to get through, but not for the cat that's chasing it."

VI. TROUBLESHOOTING

A. YOUR HEATING NEEDS

Virtually all woodstove operators at one time or another experience basic common problems. All are correctable and generally require only a minor adjustment of the stove, installation, or operating technique. In cases where weather conditions dramatically affect stove performance, the problems will be very temporary.

If you question whether or not your stove is producing adequate heat, the best way to troubleshoot the problem is to monitor the temperature of the combustors. A 1000°F combustor confirms the stove is supplying sufficient heat. Keep in mind that your house itself will regulate room/house temperatures. How well the walls, floors and ceilings are insulated, the number and size of glass windows, the tightness of outside doors, and the construction or style of your house (vaulted ceilings or other open spaces which collect large percentages of heat) all are determining factors of room temperature.

Your stove's performance is also dependant on its installation. Over-sized flues result in decreased pressure which will keep the smoke from rising out the chimney. This reduction in draft will cause the stove to die down or even force the smoke to pour into the room. If your chimney is the proper size and draft is still not easily established, there is the possibility of the chimney being too cold. Hot chimneys provide a stronger draft.

While most draft problems are directly related to the stove's installation, it is possible to check for air leaks in the stove. To check for leaks, use a candle or cigarette. While the stove is burnin briskly, hold the flame at focal points of the stove (around the casting edges, door edges, between stoves, etc.). If the flame draws into the stove, a leak exists which alters air flow through the stove. Furnace cement applied to the stove interior at the point of leakage will solve the problem.

Other draft guidelines are as follows:

AN "AIRTIGHT" HOUSE: If your home is super-insulated or especially well sealed, the air supply to it may be inadequate. This would result in a weak draft. Ducting air from the outside to the vicinity of the stove (ideally near the primary air inlet) can correct this problem.

TALL TREES OR BUILDINGS IN PROXIMITY TO YOUR FLUE EXIT: Chronic or occasional down-drafts are often a result of nearby trees and buildings which alter outside air currents.

WIND VELOCITY: Generally, the stronger a steady wind, the stronger the draft. However, "gusty" wind conditions may cause down-drafts.

BAROMETRIC PRESSURE: On balmy, wet or muggy days, a draft is generally sluggish.

BRISKNESS OF FIRE: The hotter the fire in your stove, the stronger the draft.

BREAKS IN THE CHIMNEY: An unsealed clean-out door or leaky stovepipe joints or chimney may cause inadequate draft.

SEASONAL FACTORS: Early fall and late spring are generally difficult seasons to establish proper drafts because of the outside temperature and barometric pressure factors. (The colder the outside air, the stronger the draft.)

B. TROUBLESHOOTING GUIDE

<u>Problem</u>	<u>Possible Causes</u>	<u>Solutions</u>
Stove Smokes	-Operating Technique	Open the damper and air intake one minute before opening doors.
	-Cold Chimney	Preheat the chimney when first starting a fire.
	-Blocked Chimney	Examine the chimney and stovepipe for blockage or creosote accumulations.
	-Insufficient Air Supply	Supply more air to air intake area.
	-Use of Air Insulated Chimney	Replace with a pre-fabricated insulated chimney system or a properly sized masonry chimney.
	-Oversized Chimney	Reline the chimney to the appropriate diameter.

Problem	Possible Cause	Solution
Back-Puffing or Gas Explosions	-Undersized Chimney	Install a draft inducer or replace the chimney. Lengthen it.
	-Chimney too short	
	-Air Infiltration Into The Chimney	Seal chimney connections and openings in clean-out doors.
	-More Than One Appliance Connected to the Flue	Disconnect all other appliance and seal openings.
	-Operating Technique	Open the damper and air intake one minute before opening the door and keep the air controls open for a few minutes after reloading.
Short or Uncontrolled Burn	-Extra Low Burn Rate	Burn the stove in a higher operating range.
	-Chimney Downdraft	Install a chimney cap.
	-Excessive Ash Build-up	Empty ash pan daily.
	-Unsealed or Open Doors	Close the doors tightly or replace the door gaskets.
	-Excessive Draft	Check the installation. Operate the stove at LOW BURN range.
Insufficient Heat	-Deteriorated Cement Seals	Reseal the stove with furnace cement.
	-Extra Long Chimney	Shorten the chimney.
	-Oversized Chimney	Reline the chimney to the proper diameter.
	-High Winds or Hilltop Location	Install chimney cap.
	-Poor or Green Wood	Use only air dried wood - preferably dried <u>at least</u> one year.
	-Low Burn Rate	Operate the stove at a higher burn rate.
	-Air Insulated Chimney	Replace with a pre-fabricated insulated chimney system or a properly sized masonry chimney.
	-Exterior Chimney	Insulate the chimney.
	-Poor Wood	Use only well seasoned dry wood.
	-Leaky Stovepipe or Chimney	Check the installation.
Loose Cement	-Insufficient Air Supply	Supply air to air intake area.
	-Faulty or Dirty Combustors	Inspect combustors. Clean or replace.
	-Too Much Heat Loss From House	Insulate house.
	-Stove Not Broken In Properly	Reseal stove. Observe break-in procedure.
	-Stove Used for More Than Two Years	Check for missing or loose cement and reseal.
Blistering of Enamel Castings	-Operating Technique	Do not over-fire the stove. Monitor the temperatures.
	-Excessive Draft	Check the installation. Operate the stove at a LOW BURN range.

TROUBLE SHOOTING YOUR CATALYTIC COMBUSTORS

Problem	Possible Causes	Solutions
Combustors are Plugged	-Operating Technique	Burning items that produce large quantities of fly ash. Avoid burning colored or glossy paper, artificial logs, cardboard, coal, garbage, driftwood or treated or painted wood.
	-Poor Quality Fuel or Very Wet, Punky Wood	Burn only well seasoned wood. Make sure the fire is well established and stable before closing the bypass damper.
	-Combustors Deactivated	Clean combustors or, if necessary, replace them.
Substrate Peeling/ Extreme Temperatures Present in Combustors	-Over-firing and/or Flame Impingement	Have the draft checked. Monitor the temperature in the combustors closely to avoid over-firing.
Catalyst Deactivated (Large quantities of smoke pouring from your chimney and/or excessive presence of creosote are symptoms to watch for).	-Burning Damaging Materials Previously Listed	Burn only seasoned, natural wood. Replace the deactivated combustors.
	-Normal <u>if</u> combustors do not deteriorate further. - Mishandling	<u>Do not</u> remove the combustors unless necessary. <u>Handle combustors with care!</u>
Substrate Cracking	-Combustors Fired at Extreme Temperatures -Excessive Draft, Causing an Over-Fire Situation	Avoid firing combustors above 1700°F. Check the installation. Operate the stove at LOW BURN range.

NHC, INC.

P.O. Box 1069, MORRISVILLE, VT. 05661 (802) 888-5232 FAX (802) 888-7249

* * IMPORTANT WARRANTY INFORMATION * *

Your new HearthStone Harvest has been inspected at the factory prior to shipment and is determined to be free of defects in materials and workmanship. Should a problem arise with your stove, you are protected by N.H.C.'s Limited Warranty which covers defective stove parts for a period of five years from the date you receive your stove. For more details please consult the warranty card which you will find in your stove.

Door glass, door gaskets, enameled parts and furnace cement are NOT covered by your warranty. Please note also the failure to follow the installation instructions and basic operating recommendations presented in this Owner's Manual will void your warranty, as will negligence, abuse, modification or overfiring, as determined by N.H.C. or an Authorized HearthStone Stove Dealer.

The catalytic combustors in your stove are covered by a separate warranty through the combustor manufacturer. It is important to return the warranty card to the catalytic combustor manufacturer when you receive your stove. Keep the warranty information provided by the manufacturer to refer to, if needed.

Please fill out and mail back to N.H.C. the original copy of the Warranty Validation Form enclosed in your stove. Please keep a copy of this important document with your Harvest Warranty and this Owner's Manual in a safe place for future reference. The specified copy of the Warranty Validation Form goes to your dealer for his records.

IN CLOSING.....

With proper use and care, your new Harvest will serve you faithfully for years. We recommend that you refer to this Owner's Manual whenever questions arise. Should you have any unanswered questions, problems, or comments concerning your stove, please feel free to call or write to use here at N.H.C. or contact your dealer. We are here to serve you for as long as you own your stove.

If you are planning a trip to Vermont, we cordially invite you to visit us at our factory to see the stoves being built. Morrisville is located in NorthCentral Vermont, on Route 100, ten miles north of Stowe Village. We look forward to meeting you.

Thank you for choosing HearthStone Stoves. We trust you will enjoy your Harvest.



Hergóm

MANUFACTURER OF FINE SOAPSTONE WOODSTOVES AND CAST IRON PRODUCTS

HearthStone® Stoves

SPECIFICATIONS

Maximum Heat Output (1)
Heat-Lifetm (2)
Maximum Combustion Efficiency
Size of Heated Area
Firebox
Fuel Size (3)
Maximum Rate of Burn
Minimum Rate of Burn
Height
Width
Depth
Fireplace Door Size (front)
Loading Door Size (side)
Stovepipe Size
-Metal Chimneys
-Masonry Chimneys
Flue Exit
-Freestanding Mode
-Hearth (Fireplace) Mode
Rear Flue Exit Center Line
Primary Air Control
Secondary Air Supply
Actual Weight
Shipping Weight
Crated Dimensions
Standard Equipment
Optional Equipment
Soapstone Finish (4)

Castings Finish

HEARTHSTONE HARVEST

38,000 BTU's per hour
12-14 or more hours
91%
Mid-sized house or smaller
2.2 cubic feet
18" to 20" logs
6.5 lbs. per hour
1.7 lbs. per hour
28 7/8"
26 3/4"
26 3/8"
15 7/8" X 8 3/8"
9" X 10 5/8"
6" diameter
6" inside dia.
6" inside dia. or 8" X 8"
Reversible
Top vent
Rear vent
20 5/8"
Manual
Automatic bimetallic coil
504 lbs.
544 lbs.
H-37 3/4" X W-32" X L-32 1/2"
Rear heat shield
Warming shelf
Natural buff grey
Polished
Brownstone
Matte black
Brown porcelain enamel

-
- (1) Based on latest N.H.C. Laboratory test results.
 - (2) Heat-Life is a trademark of N.H.C. and is defined as thermal capacitance or quantity of heat stored. Used here, it refers not just to burn time, but also to hours of usable heat obtained from a single load of fuel.
 - (3) The Harvest's firebox will hold 43 lbs. of 16" to 18" wood. The firebox is capable of a maximum log length of 20".
 - (4) Colors of polished stone can vary from grey to grey-green, according to natural composition. Colors of brownstone can vary from grey-brown to brown, according to natural composition.

COLORADO WOODSTOVE COMPLIANCE CERTIFICATE

PARTICULATES (AVG) 4.07 GRAMS/HOUR
CARBON MONOXIDE (AVG) 50.61 GRAMS/HOUR

COLORADO STANDARDS USING THE DILUTION TUNNEL TEST METHOD

	PARTICULATE	CARBON MONOXIDE
PHASE II (After 7/1/88)	8.5 grams/hr	200 grams/hr
HEAT OUTPUT RANGE:	9,377 BTUs/hr to 28,401 BTUs/hr	
HEAT OUTPUT RANGE DURING TESTS:	9,337; 13,774; 20,126; 28,401 BTUs/hr	
MANUFACTURED BY:	N.H.C., INCORPORATED, MORRISVILLE, VT. USA	
MODEL TYPE:	HEARTHSTONE HARVEST	
DESIGN NO.:	H-II	

Performance may vary from test values depending on actual home operating conditions and the altitude at which the stove is operated.