

INSTALLATION INSTRUCTIONS

Installation And Operation Instructions

*For Unvented
Decorative
Gas Fireplaces*

*Models
VF4-CHN
VF4-CHP
VF4-CMN
VF4-CMP*

WARNING: If the information in this manual is not followed exactly, a fire or explosion may result causing property damage, personal injury or loss of life.

– Do not store or use gasoline or other flammable vapors and liquids in the vicinity of this or any other appliance.

– WHAT TO DO IF YOU SMELL GAS

- Do not try to light any appliance.
- Do not touch any electrical switch; do not use any phone in your building.
- Immediately call your gas supplier from a neighbor's phone. Follow the gas supplier's instructions.
- If you cannot reach your gas supplier, call the fire department.

– Installation and service must be performed by a qualified installer, service agency or the gas supplier.

This is an unvented gas-fired heater. It uses air (oxygen) from the room in which it is installed. Provisions for adequate combustion and ventilation air must be provided. Refer to Combustion and Ventilation Air Section, Page 3.

Due to high temperatures, the appliance should be located out of traffic and away from furniture or draperies.

Do not place clothing or other materials on or near this appliance.

PLEASE RETAIN THIS MANUAL FOR FUTURE REFERENCE.

WARNING: DO NOT USE A BLOWER INSERT, HEAT EXCHANGER INSERT OR OTHER ACCESSORY NOT APPROVED FOR USE WITH THIS HEATER.

***Models Covered In This Document
Are Part Of Superior's
VF-4000 SERIES***



TABLE OF CONTENTS

General Information	page 2
Inventory	page 2
Tools and Building Supplies	page 2
Installation Applications	page 2
Important Safety Information	page 2
Codes	page 3
Combustion and Ventilation Air	page 3
Location of Fireplace	page 4
Clearances	page 4
Preinstallation	page 5
Installation – Built-In	page 5
Connecting Gas Line	page 6
Gas Pressure Check	page 6
Electrical Wiring – Optional Blower ..	page 7
Finished Wall Details	page 8
Installation – Surround	page 8
Log Assembly	page 8
Flame Appearance	page 9
Optional Equipment	page 10
Blower Kit	page 10
Operation and Care	page 11
Cleaning and Servicing	page 11
Replacement Parts	page 11
Accessories/Components	page 12
Appliance Specifications	page 13
CH Operating Instructions	page 14
CM Operating Instructions	page 16
Troubleshooting Guide	page 18
Replacement Parts List	page 20
Warranty	page 24

GENERAL INFORMATION

The VF4 Series Unvented Room Heaters covered in this manual feature ceramic fiber split logs which glow realistically when the heater is operating.

These heaters are manually controlled. Models VF4-CMN and VF4-CMP feature a gas valve incorporating a millivolt operating system.

A spark ignition system (piezo) allows the heater pilot gas to be lit without the use of matches or batteries and permits operation of the heater during a power outage.

These heaters are fitted with a specially designed pilot (ODS) which responds to the amount of oxygen available in the room and shuts the heater off before the oxygen level drops below 18%. The pilot can be relit only when fresh air is available. Refer to the Combustion and Ventilation Air section.

The VF4 Series Unvented Room Heaters may be built into a framed wall, or installed in an optional oak surround.

This heater has been tested to the standards of ANSI Z21.11.2 unvented heaters.

Do not install these unvented room heaters in a bedroom or bathroom as all units exceed maximum allowable BTU/Hr input of 10,000.

Inventory

Unvented Gas Fireplace
Gas connection fittings
Installation and Operating Instructions

Tools and Building Supplies Normally Required

Tools Should Include:
Phillips screwdriver

Hammer
Saw and/or Sabersaw
Measuring tape
Electric drill and bits
Pliers
Square
Piping complying with local codes
Pipe wrench
Tee joint
Pipe compound

Building Supplies Should Include:

Framing materials
Wall finishing materials
Caulking materials (noncombustible)
Fireplace surround materials

Installation Applications

1. Fireplace built into a framed wall.
2. Fireplace installed with oak surround and/or platform (Refer to the SUR-5/6 unfinished oak veneer surround installation instructions, P/N 903593).

Check the inventory list to be sure that you have all the necessary parts in usable condition. Also check for concealed damage.

IMPORTANT SAFETY INFORMATION

INSTALLER: PLEASE LEAVE THESE INSTRUCTIONS WITH THE OWNER.

OWNER: PLEASE RETAIN THESE INSTRUCTION FOR FUTURE REFERENCE.

IMPORTANT: BEFORE STARTING YOUR HEATER INSTALLATION, READ THESE INSTALLATION INSTRUCTIONS CAREFULLY TO BE SURE YOU UNDERSTAND THEM COMPLETELY AND IN ENTIRETY. FAILURE TO FOLLOW THESE INSTRUCTIONS COULD CAUSE A HEATER MALFUNCTION RESULTING IN SERIOUS INJURY AND/OR PROPERTY DAMAGE.

UNVENTED GAS ROOM HEATER SPECIFICATIONS AND TECHNICAL DETAILS

Model No.	Gas Type	Maximum BTU/HR	Valve Operation	Ignition	Regulator Pressure Setting	Gas Inlet Pressure
VF4-CHN VF4-CMN	Natural	25,000	Manual	Piezo	5" w.c.	Max 10 ½" w.c. Min. 6" w.c.
VF4-CHP VF4-CMP	Propane/ LPG	25,000	Manual	Piezo	10" w.c.	Max 13" w.c. Min. 11" w.c.

WARNING: FAILURE TO COMPLY WITH THE INSTALLATION AND OPERATING INSTRUCTIONS PROVIDED IN THIS DOCUMENT WILL RESULT IN AN IMPROPERLY INSTALLED AND OPERATING UNVENTED ROOM HEATER, VOIDING ITS WARRANTY. ANY CHANGE TO THIS HEATER AND/OR ITS OPERATING CONTROLS IS DANGEROUS. IMPROPER INSTALLATION OR USE OF THIS HEATER CAN CAUSE SERIOUS INJURY OR DEATH FROM FIRE, BURNS, EXPLOSION OR CARBON MONOXIDE POISONING.

WARNING: THESE APPLIANCES ARE DESIGNED TO OPERATE ON NATURAL OR PROPANE GAS ONLY. THE USE OF OTHER FUELS OR COMBINATION OF FUELS WILL DEGRADE THE PERFORMANCE OF THIS SYSTEM AND MAY BE DANGEROUS.

Carbon Monoxide Poisoning: Early signs of carbon monoxide poisoning are similar to the flu with headaches, dizziness and/or nausea. If you have these signs, obtain fresh air immediately. Turn off the gas supply to the heater and have it serviced by a qualified professional, as it may not be operating correctly.

- Due to high temperatures, the heater should be located out of traffic and away from furniture and draperies.
- Children and adults should be alerted to the hazard of high surface temperatures and should stay away to avoid burns or clothing ignition.
- Young children should be carefully supervised when they are in the same room with the heater.
- Do not place clothing or other flammable material on or near the heater for the purpose of drying.
- Installation and repair should be done by a qualified service person. The heater should be inspected before use and at least annually by a professional service person. More frequent cleaning may be required due to excessive lint from carpeting, bedding material, etc. It is important that control compartments, burners and circulating air passageways of the heater be kept clean.
- Allow the heater to cool before servicing. Always shut off any electricity or gas to the heater while performing service work.

- Do not install the VF4 series heaters in a bedroom or bathroom.
- The installation must conform with local codes or, in the absence of local codes with the National Fuel Gas Code, ANSI Z223.1.
- The heater and its individual shut-off valve must be disconnected from the gas supply piping system while performing any tests of the gas supply piping system at pressures in excess of ½ psig.
- The heater must be isolated from the gas supply piping system by closing its individual manual shut-off valve during any pressure testing of the gas supply piping system at test pressures equal to or less than ½ psig.
- Any safety screen or guard removed for servicing the heater must be replaced prior to operating the heater.
- Keep heater area clear and free from combustible materials, gasoline and other flammable vapors and liquids.
- Do not use these appliances if any part has been under water. Immediately call a qualified professional service technician to inspect the appliance and to replace any parts of the control system and any gas control which have been under water.
- Input ratings are shown in BTU per hour and are for elevations up to **7,000** feet. Operating heater above elevations of 7,000 feet may cause ODS pilot outage.
- Ensure that the heater is clean when operating. Excessive dust accumulation on the burner and logs will increase the amount of carbon monoxide formation and could lead to carbon monoxide poisoning and death.

CODES

Adhere to all local codes or in their absence the latest edition of The National Fuel Gas Code ANSI Z223.1 or NFPA54 which can be obtained from The American National Standards Institute, Inc. (1430 Broadway, New York, NY, 10018) or National Fire Protection Association, Inc. (Batterymarch Park, Quincy, MA, 02269).

COMBUSTION AND VENTILATION AIR

This heater shall not be installed in a confined space or unusually tight construction unless provisions are provided for adequate combustion and ventilation air.

Unusually tight construction is defined as construction where:

- a. wall and ceilings exposed to the outside atmosphere have a continuous water vapor retarder with a rating or one perm or less with openings gasketed or sealed, and
- b. weather stripping has been added on operable windows and doors, and
- c. caulking or sealants are applied to areas such as joints around window and door frames, between sole plates and floors, between wall-ceiling joints, between wall panels, at penetrations for plumbing, electrical, and gas lines, and at other openings.

Use the following equations to determine if you have a confined or unconfined space.

1. Determine the volume of space — ft³.
 Length x Width x Height = _____ ft³
 (Include adjoining rooms with doorless passageways or ventilation grills between rooms.)

Example: 20' (L) x 16' (W) x 8' (H) = 2560 ft³

2. Divide the volume of space by 50 ft³ to determine the maximum BTU/Hr the space can support.

_____ (volume of space – ft³) / 50 ft³ =
 (Maximum BTU/Hr the space can support)

Example: 2560 ft³ / 50 ft³ = 51.2
 or 51,200 BTU/Hr the space can support.

3. Add the BTU/Hr of all the fuel burning appliances in the space.

Vent-Free heater	_____	BTU/Hr
Gas appliance #1*	_____	BTU/Hr
Gas appliance #2	+ _____	BTU/Hr
Total =	_____	BTU/Hr

Example:
 VF4 Vent-free heater 25,000 BTU/Hr
 Gas appliance #1 34,000 BTU/Hr
 (water heater)
 Total = 59,000 BTU/Hr

* Do not include direct-vent gas appliances. Direct-vent is sealed combustion and draws combustion air from the outdoors.

4. Compare the maximum BTU/Hr the space can support with the actual amount of BTU/Hr used.

_____ BTU/Hr
(max. the space can support)
_____ BTU/Hr
(actual amount of BTU/Hr used)

Example:

51,200 BTU/Hr
(max. the space can support)
59,000 BTU/Hr
(actual amount of BTU/Hr used)

The space in the above example is a confined space because the actual BTU/Hr used is more than the maximum BTU/Hr the space can support. You must provide additional fresh air.

WARNING: IF THE AREA IN WHICH THE HEATER MAY BE OPERATED IS SMALLER THAN THAT DEFINED AS AN UNCONFINED SPACE OR IF THE BUILDING IS OF UNUSUALLY TIGHT CONSTRUCTION, PROVIDE ADEQUATE COMBUSTION AND VENTILATION AIR BY ONE OF THE METHODS DESCRIBED IN THE NATIONAL FUEL GAS CODE, ANSI Z223.1 1992, SECTION 5.3 OR APPLICABLE LOCAL CODES.

Your options are:

- a. Rework equations adding the space of adjoining room(s). If the extra volume provides an unconfined space, then remove door or add ventilation grills between rooms. Refer to National Fuel Gas Code, ANSI Z223.1 1992, Section 5.3.
- b. Vent room directly to the outdoors. Refer to National Fuel Gas Code, ANSI Z223.1 1992, Section 5.3.
- c. Install a lower BTU/Hr heater, to make the area an unconfined space.

If the actual BTU/Hr used is less than the maximum BTU/Hr the space can support, then the space is an unconfined space. You will need no additional fresh air ventilation for an unconfined space.

LOCATION OF FIREPLACE

Carefully select the best location for installation of your VF4 series Unvented Room Heater. The following factors should be taken into consideration:

- Clearance to side wall, ceiling, woodwork and windows.
- Location must not be affected by drafts caused by kitchen exhaust fans, return air registers for forced air furnaces/air conditioners, windows or doors.
- Installation must provide adequate ventilation and combustion air.
- Do not install the VF4 series heaters in a sleeping room or bathroom.
- Never obstruct the front opening of the heater or restrict the flow of combustion and ventilation air.
- This appliance may be installed in an aftermarket* manufactured (Mobile) Home, where not prohibited by state or local codes.
*Aftermarket: Completion of sale, not for purpose of resale, from the manufacturer.
- Minimize modifications to existing construction. Refer to *Figure 1* for location suggestions.

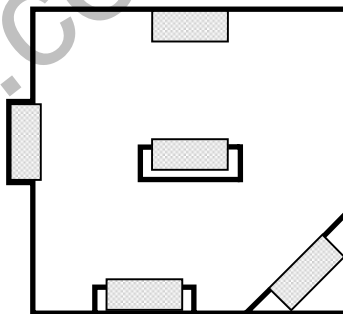

Figure 1

To ensure even heat distribution, it is best to position the heater centrally against the longest wall of the room. Make sure there is adequate ventilation where the heater is installed. The gas appliance will shut off if the oxygen level falls below 18%.

These appliances are uniquely suited for installations requiring a utility shelf positioned directly above the fireplace. Utility shelves like these are commonly used for locating television sets and decorative plants.

To provide for the lowest possible shelf surface, combustible materials used to support a utility shelf directly above these appliances should be positioned just above the appliance top spacers. The minimum height from the base of the VF4 to the underside of combustible materials used to construct a utility shelf is 37 1/4" (946 mm).

The appliance should be mounted on a fully supported base extending the full width and depth of the unit. The appliance may be located on or near conventional construction materials. However, if installed on combustible materials, such as carpeting, vinyl tile, etc., a metal or wood barrier covering the entire bottom surface must be used.

If the appliance is to be elevated above floor level, a solid continuous platform must be constructed.

WARNING: MAINTAIN MINIMUM CLEARANCES.

Do not install in the vicinity of gasoline or other flammable liquids. The heater must be kept clear and free from these combustible materials and may not be located near where they are stored.

Clearances

WARNING: DO NOT INSTALL VF SERIES UNVENTED ROOM HEATERS IN SLEEPING QUARTERS, OR IN RECREATIONAL VEHICLES.

WARNING: DO NOT INSTALL THE VF UNVENTED ROOM HEATER:

- WHERE CURTAINS, FURNITURE, CLOTHING OR OTHER FLAMMABLE OBJECTS ARE LESS THAN 42" FROM THE FRONT OF THE UNVENTED ROOM HEATER.
- IN HIGH TRAFFIC AREAS.
- IN WINDY OR DRAFTY AREAS.

Ensure the minimum clearances shown in *Figures 2 and 3* are maintained.

Minimum clearance to combustibles are:

Appliance: side and back - 0"
 floor - 0"
 adjacent wall - 6"
 ceiling - 37 1/2" (953 mm)

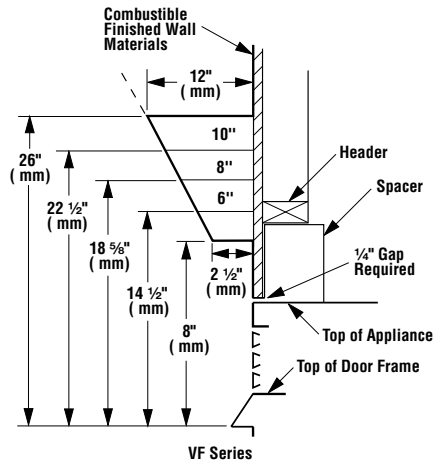

Figure 2

A hearth extension is not required with this appliance. If a hearth extension is used, do not block the lower control compartment door. Any hearth extensions used is for appearance only and does not have to conform to standard hearth extension installation requirements.

Note: Combustible wall finish materials and/or surround materials must not be allowed to encroach the area defined by the appliance front face (black sheet metal). Never allow combustible materials to be positioned in front of or overlapping the appliance front face.

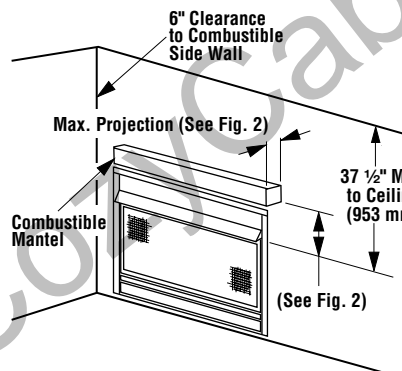

Figure 3

PREINSTALLATION

Check that all listed parts have been received.

Carefully inspect the heater case and contents for shipping damage and immediately inform the dealer from whom you purchased the gas fireplace if any damage is found.

The appliance is shipped with all gas controls and components installed and pre-wired. Remove the shipping carton. The nailing flanges are installed at each side of the appliance backwards when shipped from the factory to protect the unit from shipping damage. Remove the nailing flanges and retain for use when installing the appliance in framing. Remove three screws and remove the screen panel. Remove the logs and set aside.

Check Gas Type

This appliance can only be connected to the gas type specified on the appliance data plate. This appliance can not be modified in the field for a different gas type. If the gas type to be used is not the one specified contact the dealer to obtain the correct gas appliance.

Note: Illustrations shown in this manual reflect "typical" installations with nominal dimensions and are for design and framing reference only. Actual installations may vary due to individual design preferences. However, always maintain minimum clearances to combustible materials and do not violate any specific installation requirements.

Note: The following steps represent the normal sequence of installation. Each installation is unique, however, and might require a different sequence.

CAUTION: HEATERS CREATE WARM AIR CURRENTS. THESE CURRENTS MOVE HEAT TO WALL SURFACES NEXT TO HEATER. INSTALLING HEATER NEXT TO VINYL OR CLOTH WALL COVERINGS OR OPERATING HEATER WHERE IMPURITIES IN THE AIR (SUCH AS TOBACCO SMOKE) EXISTS, MAY DISCOLOR WALLS.

Step 1. Position heater in desired location (freestanding, onto surround base or into prepared framing) and secure.

Step 2. Plumb gas line. (Gas connections should only be performed by an experienced, licensed/certified tradesman.)

Step 3. Assemble logs and test flame appearance.

Step 4. Complete finish wall material, surround and optional hearth extension to your individual taste.

INSTALLATION STEPS

Built-In Systems

WARNING: DO NOT ALLOW FANS TO BLOW DIRECTLY INTO THE FIREPLACE. AVOID ANY DRAFTS THAT ALTER BURNER FLAME PATTERNS.

WARNING: DO NOT USE A BLOWER INSERT, HEAT EXCHANGER INSERT OR OTHER ACCESSORY NOT APPROVED FOR USE WITH THIS HEATER.

Do not burn solid fuels in this listed unvented gas room heater.

Step 1. Frame VF4 appliance enclosures as illustrated in Figures 4, 5 and 6.

Note: The framed depth (15 1/2" for a flat wall, 29" for a corner VF4) must always be measured from a finished surface. If a wall covering such as drywall is to be attached to the rear wall, then the dimension must be measured from the drywall surface.

Note: Framing dimensions in Figures 4 - 6 are calculated for a nailing flange depth of 1/2" (13 mm).

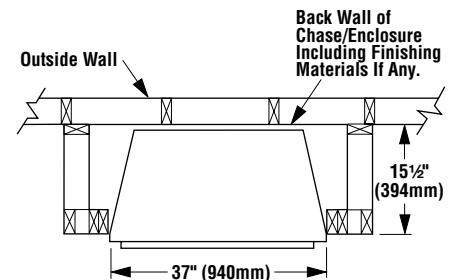

Figure 4

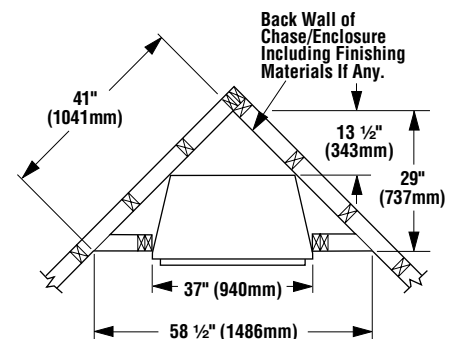

Figure 5

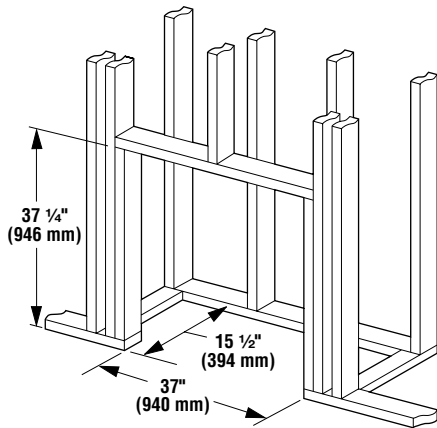

Figure 6

Step 2. Route a 1/2" (13 mm) gas line along the left or right side framing (Figure 7).

All appliances have a 3" long 3/8" NPT nipple installed at the regulator. To quickly and easily complete the gas line routing, use the gas flex line kit, Model GFLV.

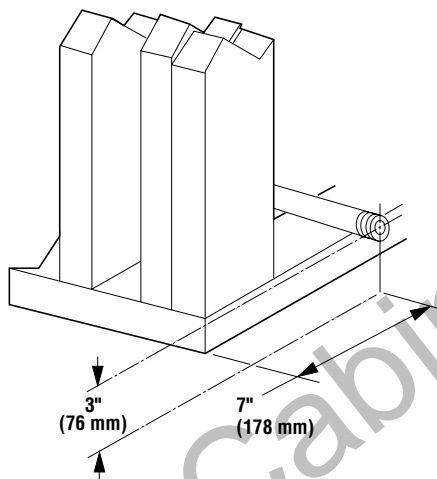

Figure 7

Step 3. Install the nailing flanges (as shown in Figure 8) with three (3) screws each. Align with the three holes on each side of the appliance (refer to Figure 8).

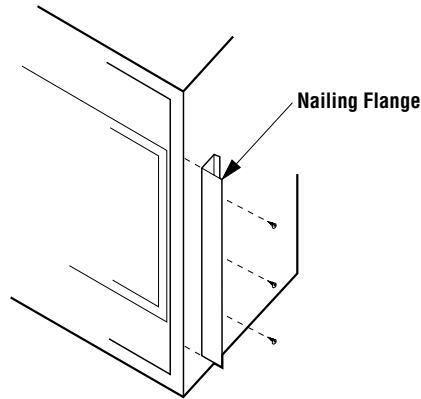

Figure 8

Step 4. Position appliance into prepared framing, secure with 6d nails at the nailing flange along each side.

Step 5. Connecting Gas Line – Make gas line connections. All codes require a shut-off valve mounted in the supply line. Figure 9 illustrates two methods for connecting the gas supply. Installation methods and materials must be in compliance with local codes.

The gas control valve is located in the lower control compartment. To access the valve open the lower control compartment door (Figure 10).

The regulator has a 3/8" NPT thread inlet port and is fitted with a 3" (76 mm) long nipple, 3/8" NPT on both ends. Plan the connections accordingly.

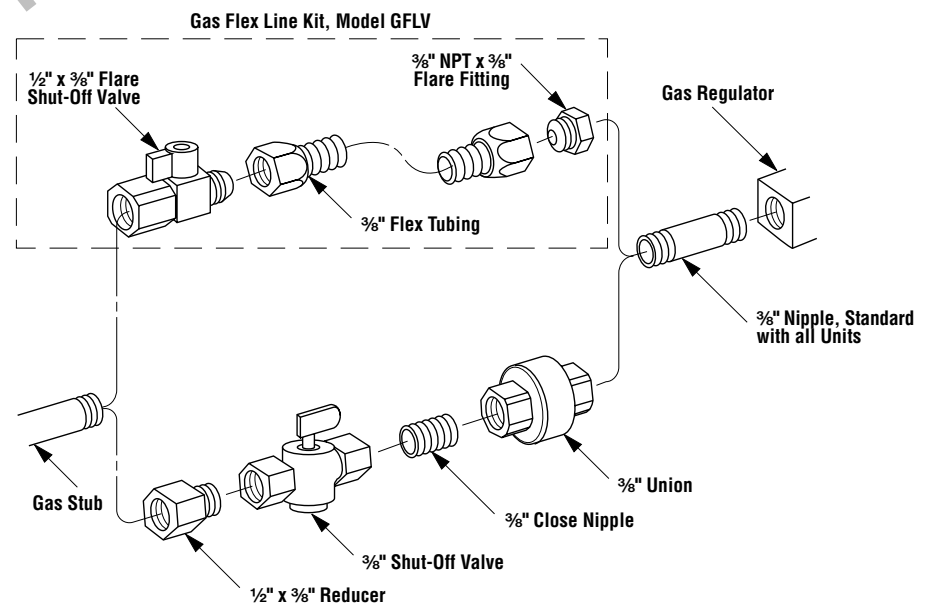

Figure 9

We recommend that the gas line be routed for the right side of the appliance to ensure adequate access to the rear lower compartment for installation and servicing of the optional FAB-1100 blower.

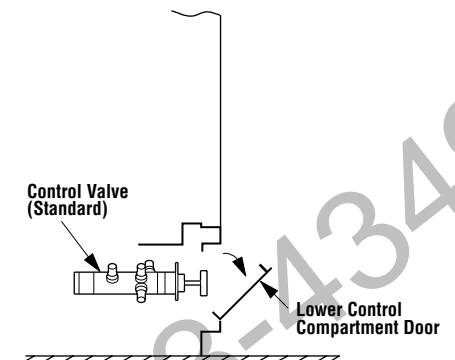

Figure 10

Secure all joints tightly using appropriate tools and sealing compounds (ensure propane resistant compounds are used in propane applications). Turn on gas supply and test for gas leaks using a soapy water solution. **Never use an open flame to check for leaks.**

- A. Mix a 50% dish soap, 50% water solution.
- B. Light the appliance (refer to safety and lighting instructions on pages 14 and 16).

C. Brush all joints and connections with the soapy water solution to check for leaks. If bubbles are formed, or gas odor is detected, turn the gas control knob to the "OFF" position. Either tighten or refasten the leaking connection and retest as described above.

D. When the gas lines are tested and leak free, observe the individual tongues of flame on the burner. Make sure all ports are open and producing flame evenly across the burner. If any ports are blocked, or partially blocked, clean out the ports.

An external regulator must be used on all propane (L.P.G.) heaters, in addition to the regulator fitted to the heater, to reduce the supply tank pressure to 13" w.c. (maximum).

WARNING: CONNECTING DIRECTLY TO AN UNREGULATED PROPANE TANK CAN CAUSE AN EXPLOSION.

Step 6. Installing the Optional Remote Wall Switch (VF4-CMN/P models only) – The millivolt system comes from the factory wired as shown in Figure 11. Select a convenient location for the remote wall switch and connect the wiring to the appliance (Figure 12).

CAUTION: DO NOT CONNECT THE OPTIONAL REMOTE SWITCH TO A 120V POWER SUPPLY.

Note: The optional rocker switch is mounted to the appliance and wired in the same way as the remote wall switch.

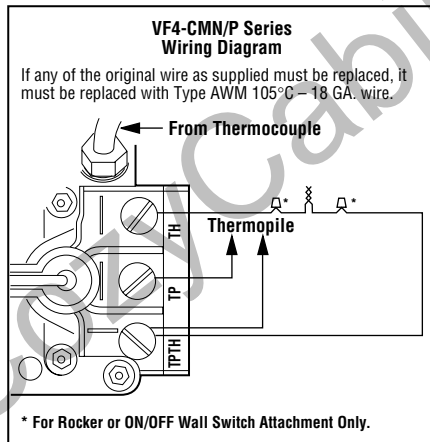

Figure 11

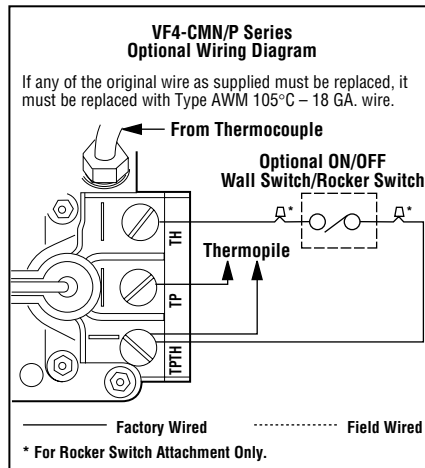

Figure 12

Step 7. Installing the Optional Forced Air Blower Kit Wiring – A receptacle plate is provided for the installation of the FAB-1100 forced air blower kit (optional). Electrical power must be provided to this plate to operate the blower.

Route a 3-wire, 120Vac power line with control switch to the lower left front corner of the appliance. Supply wires are to be connected to the outlet as shown in Figure 13, ensuring that the polarity (as determined by the colors of the wires) is exactly as shown. The black and red wire loop must be left intact, with the mating connectors connected.

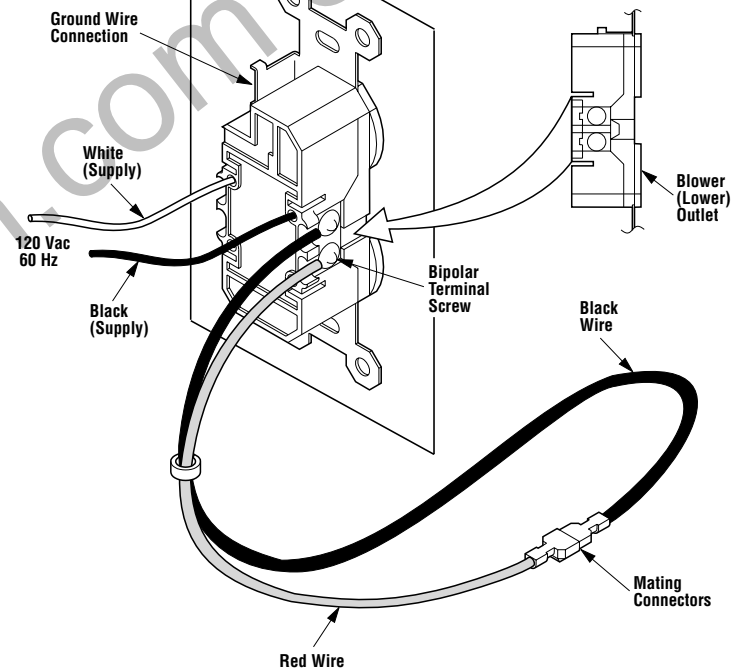
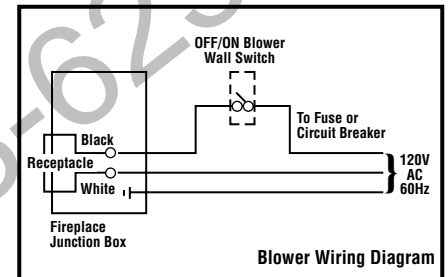

Figure 13

Note: Supply wires may be alternatively connected to the outlet using the screw terminals, however the black supply wire must be ganged wired to the same terminal that the pre-wired black wire is attached to and the white supply wire must be connected to the opposite side of the outlet.

IMPORTANT: Ground lead must be connected to the green screw located on the junction box cover plate. Failure to do so will prevent the appliance from operating. The appliance must be electrically grounded in accordance with local codes or, in the absence of local codes, the National Electrical Code, ANSI/NFPA 70-(latest edition). (In Canada, the current CSA C22-1 Canadian Electrical Code.)

The forced air blower kit may be mounted at initial appliance installation or at any time thereafter. Follow the instructions provided with the blower kit.

Finished Wall Details

It is sometimes best to frame the appliance after it has been positioned in place. Frame with 2 x 4s or heavier lumber. Always frame in accordance with local building codes.

Note: The header may rest on the top spacers but must not be notched to fit around them.

In order to install the appliance facing flush with the finished wall, position the framework to accommodate the thickness of the finished wall (Refer to Figures 2 and 3).

If you live in a cold climate, seal all cracks around your appliance with noncombustible material and wherever cold air could enter the room. It is especially important to insulate outside chase cavity between studs and under floor on which appliance rests, if floor is above ground level.

Proceed to Step 11.

Surround Installations

Note: The VF4 series appliances must be installed giving full consideration to the clearance and height requirements identified in this manual.

Step 8. Position Heater – Place the heater in desired location. It may be helpful to temporarily assemble the surround around the appliance to properly locate the unit. Refer to Figure 14 for floor and platform installations. If the heater is to be installed into a framed wall refer to the built-in assembly steps beginning on page 4.

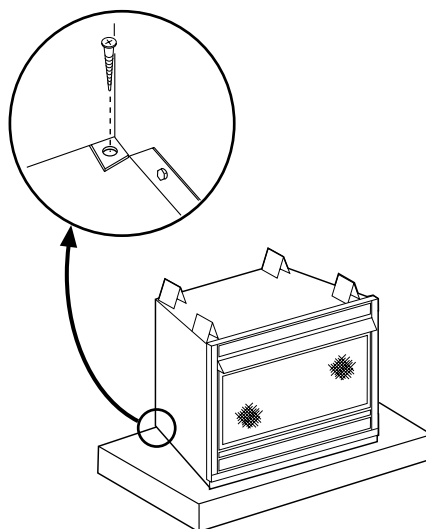

Figure 14

Note: The heater may be installed directly on a floor made of standard combustible wood construction materials. Do not install the heater directly on carpeting or other soft floor covering such as vinyl tile or flooring materials. Use a wood or metal panel that extends the full width and depth of the heater between the heater and any soft floor covering material. Refer to Figure 20 for base dimensions.

Step 9. Secure Heater – Bend the tabs down (Figure 14). Using two (2) screws securely tighten the appliance to the platform.

Note: Heater must be anchored to the floor or platform.

Step 10. Install Optional 120V Wiring – Refer to Step 7 for wiring instructions.

Connecting Gas Line

Step 11. A qualified gas appliance installer must connect the gas room heater to the gas supply.

Consult all local codes and refer to Step 5.

The heater gas inlet connection is 3/8" NPT, located on the right side facing the heater. If a left side connection is required, route the gas line under the valve to end at the right hand side for connection to the inlet. This may be required to allow for installation of the blower.

When tightening up the joint to the valve hold the valve securely with a wrench to prevent the valve from moving.

Step 12. For Surround Installations Only – Finish the assembly of the surround components and secure the surround to the appliance.

Assembling the Logs

WARNING: DO NOT ADD EXTRA LOGS OR ORNAMENTS SUCH AS PINE CONES, VERMICULITE OR ROCK WOOL. USING THESE ADDED ITEMS CAN CAUSE SOOTING.

WARNING: DO NOT PLACE ANY LAVA ROCK ON LOGS OR BURNERS. THIS MAY CAUSE SOOTING.

Step 13. The heater includes a unitized set of five (5) ceramic fiber logs. The heater and logs are assembled as shown in Figure 15. Handle these logs with great care. The logs can be easily damaged, but when handled properly they can provide years of performance and enjoyment.

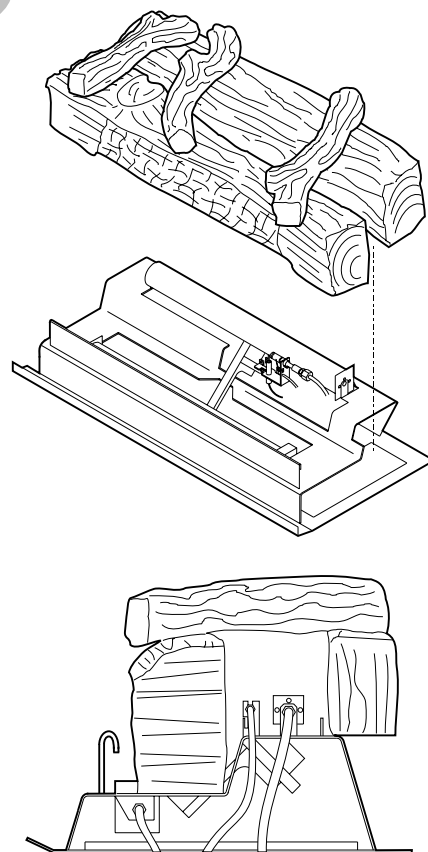

Figure 15

After setting the logs into position as described above, ensure they are properly and firmly situated. The heater will not function as intended if the logs are not correctly positioned.

Periodically check the positioning of the logs.

WARNING: FAILURE TO POSITION THE PARTS IN ACCORDANCE WITH THESE DIAGRAMS OR FAILURE TO USE ONLY PARTS SPECIFICALLY APPROVED WITH THIS HEATER MAY RESULT IN PROPERTY DAMAGE OR PERSONAL INJURY.

Flame Appearance

REFER TO THE OPERATING INSTRUCTIONS LOCATED AT THE BACK OF THIS MANUAL BEFORE LIGHTING THE HEATER TO OBSERVE THE FLAMES.

Flames from the pilot, front and rear burner should be visually checked as soon as the heater is installed. In addition a periodic visual check of the flames should be made. The pilot flame should always be present when the heater is in operation and should just envelope the tip of the thermocouple (Figure 16).

WARNING: NO ADJUSTMENTS ARE TO BE MADE TO THE ODS PILOT SYSTEM. TAMPERING WITH THIS SYSTEM CAN BE EXTREMELY HAZARDOUS.

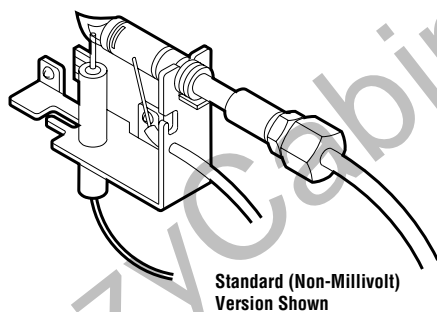

Figure 16

An incorrect pilot flame is shown in Figure 17. This pilot flame will cause the thermocouple to cool. When the thermocouple cools, the heater will shut off. If pilot flame pattern is incorrect, or if heater shuts off, contact your service representative.

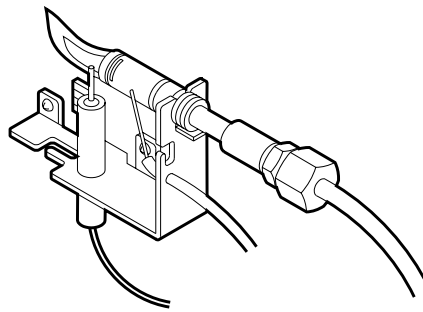

Figure 17

In normal operation, at full rate, after 15 minutes the following flame appearance should be observed:

Rear Burner Flame Characteristics – The rear flames should be yellow. The flames should extend about 3 – 4" above the front log for natural gas and 2 – 3" above for propane (L.P.G.) gas (Figure 18).

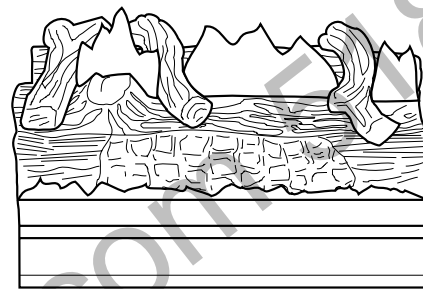

Figure 18

Main Burner – The flames at the front burner holes will be blue becoming yellowish as they hit the bark-like texture of the base and front face of the front log (Figure 18).

Appliance Operation

WARNING: THE LOWER CONTROL COMPARTMENT AREA AND LOWER CONTROL COMPARTMENT ACCESS DOOR ARE EXTREMELY HOT WHEN THE APPLIANCE IS IN OPERATION. EXERCISE EXTREME CARE WHEN ACCESSING THIS AREA. TOUCH ONLY THE FAR ENDS OF THE LOWER CONTROL COMPARTMENT DOOR WHEN OPENING WHILE THE APPLIANCE IS HOT.

Step 14. Checking the System – With gas line installed run initial system checkout before closing up the front of the unit. Follow the pilot lighting instructions on page 15.

Note: Instructions are also found on the pull out panel located on the bottom surface of the appliance.

When first lighting the appliance, it will take a few minutes for the line to purge itself of air. Once purging is complete, the pilot and burner will light and operate as indicated in the instruction manual. Subsequent lightings of the appliance will not require such purging. Inspect the pilot flame (remove logs, if necessary, handling carefully).

The pilot flame should be steady, not lifting or floating. Flame should be blue in color with traces of orange at the outer edge.

The top $\frac{3}{8}$ " (10 mm) at the pilot thermocouple should be engulfed in the pilot flame (NG only).

Replace logs if removed for pilot inspection.

To light the burner; rotate the gas valve control knob counterclockwise to the "ON" position.

Step 15. Installing the Hood Assembly – Attach the hood assembly over the firebox opening with three (3) screws.

Step 16. Installing the Screen Assembly – Position the screen assembly in front of the firebox opening, with the joint in the gasket down (Figure 19). Locate the three (3) tabs at the bottom edge of the frame into the three (3) brackets at the base of the fireplace front opening. Lean the frame back towards the fireplace. Install the three (3) $\frac{1}{4}$ "-20 x 1" Phillips pan head screws removed previously and tighten to secure.

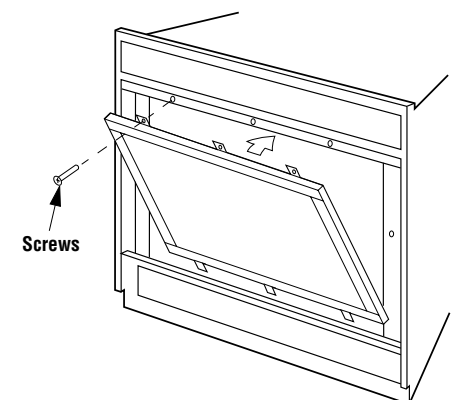

Figure 19

OPTIONAL EQUIPMENT

An incomparable package of options are available for use with these appliances. These options can both customize the operation of these unique appliances and enhance their beauty and charming appeal. All options are available in kit form, are easy to install and are packaged complete with all required parts and instructions. Some of the option kits need to be fitted prior to completing the installation of the appliance. The following paragraphs detail the kit options available for use with the appliances covered in this manual.

These outstanding optional items can be added individually or in sets of two or more to customize your vent-free appliance to fit your homes unique needs. Kit part numbers are provided on page 12 along with descriptive illustrations.

The appliances covered in this manual are heater rated and produce a great deal of heat. Decorative brass trim pieces and hoods may tarnish because of their proximity to the heater opening and front face. Tarnishing of these pieces is normal, unavoidable and should be expected.

Forced Air Kit

The FAB-1100 assembly provides a forced air circulation feature for your appliance. This kit mounts directly into the lower intake chamber with an electrical connection made at the receptacle provided. The appliance must have an independent 120Vac power line incorporated at the time of installation. Refer to Step 6 of the installation instructions supplied with the forced air kit (Figures 20 and 21).

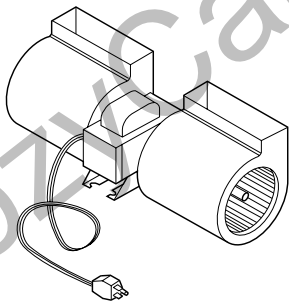

Figure 20

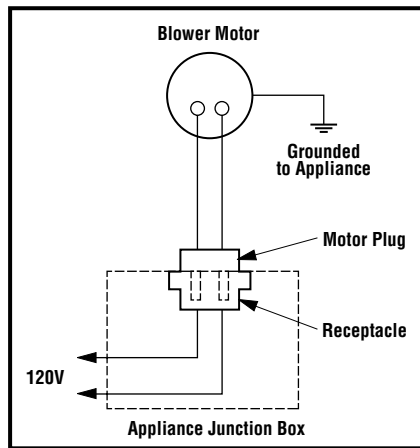

Figure 21

Brass Louver Kit

Brass louvers are available for use with these appliances. These louvers are designed to replace the standard black louvers that are provided with the appliance. The brass louver kit includes six (6) louvers that simply snap into place. They provide a touch of elegance to the VF appliance. This kit can be retrofitted to previously installed appliances.

Brass Square Surround Kit

A decorative brass square surround kit is available for use with these appliances. The BSK-5 is designed to attach directly to the front face of the appliance at its extreme edges. The BSK-5 provides a picture frame finish for the appliance 2 1/2" wide. The brass square surround kit can be retrofitted onto previously installed appliances.

Square Trim Kit

A square trim kit is available for use with this appliance. This kit is easy to install and does not require hardware to attach it as designed, directly to the standard door frame. The four piece square trim kit can be installed without the bottom or bottom and side pieces to customize the look of our appliance. This kit can be retrofitted to previously installed appliances.

Decorative Volcanic Stone

The decorative volcanic stone, Model DVS, can be used to enhance the look of your appliance. Spread the decorative volcanic stone evenly around the bottom of the firebox.

Refractory Liner Kit

One of the most beautiful enhancements you can make to this appliance is the addition of refractory liners. The refractory liner kit includes tan ceramic fiber panels for the rear and side walls of the firebox. The ceramic fiber panels have brick-like features in relief. To install the three panels, simply place them in position against the firebox walls. This kit can be retrofitted into previously installed appliances.

Screen Panel Kit

An optional fixed fine mesh screen panel can be installed on the VF4 Series Units. This screen panel is easy to install. This kit can be retrofitted to previously installed VF4 appliances.

Gas Flex Line with Valve

A gas flex line kit is available to aid in attaching the appliance to the gas supply. This kit can only be used where local codes permit. The kit includes a 1/2" NPT to 3/8" flare in line shut-off valve, a 12" flex line 3/8" female flare through and a 3/8" flare to 3/8" NPT fitting. The components of this kit are rated for both natural and propane gas. This kit is designed to be used as an aid in installing the appliance.

WARNING: CHILDREN AND ADULTS SHOULD BE ALERTED TO THE HAZARDS OF HIGH SURFACE TEMPERATURES. USE CAUTION AROUND THE APPLIANCE TO AVOID BURNS OR CLOTHING IGNITION. YOUNG CHILDREN SHOULD BE SUPERVISED WHEN THEY ARE IN THE SAME ROOM AS THE APPLIANCE.

Remote Control Kit

The Model RCK adds the convenience of remote control for your millivolt controlled appliance. The kit includes a wireless, hand held transmitter and a receiver that replaces the wall switch. This special receiver permits either manual or remote control modes. Both receiver and transmitter operate on standard 9 volt batteries (not included). Refer to the RCK installation instruction for specific details.

Wall Switch Kit

An optional wall switch kit can be installed along with the millivolt controlled appliances. The kit consists of a standard UL wall switch with cover plate. This kit provides for remote (wall) operation of the appliance. Replace the wall switch and cover plate of this kit with the components of the RCK and you can have true remote control of your vent-free appliance, turning it on and off from your favorite easy chair. The wall switch kit should be installed along with the appliance. Refer to *Figure 12* and Step 6 for detailed installation instructions.

Rocker Switch Kit

An optional rocker switch kit can be installed directly on VF4-CMN/P series appliances to provide for On and Off operation in lieu of a wall switch. This kit is designed to install in the lower control compartment out of view and is perfect for use in high volume areas such as lobbies and model homes where limited access to the appliance On/Off switch is desirable. This kit can be retrofitted to previously installed appliances and may be temporarily installed in place of other switch circuitry.

Wall Thermostat Kit

A wall thermostat kit is available for use with the millivolt controlled appliances. The wall thermostat is designed to be wired directly to the appliance millivolt gas control circuit and provide automatic On/Off control of the appliance to maintain a desired temperature within the room.

OPERATION AND CARE OF YOUR APPLIANCE

1. Blower operation may be controlled through the ON/OFF unit rocker switch, located in the lower control compartment.

2. These heater rated units are equipped with a two stage (HI, LOW) gas control valve. To set the burner at the HI and LOW settings, rotate the control knob to the desired position.

3. When lit for the first time, the appliance will emit a slight odor for an hour or two. This is due to the "burn-in" of the internal paints and lubricants used in the manufacturing process. Additionally, when lit for the first time, this appliance may produce smoke, this is normal and should be expected. For the first few hours, operate the appliance with doors and windows open to encourage the dissipation of smoke and fumes.

4. Keep lower control compartment clean by vacuuming or brushing at least twice a year. More frequent cleanings may be required due to excessive lint from carpeting, bedding materials, etc. It is important that the control compartments, burners and circulating air passageways of the heater be kept clean.

5. Always turn off gas to pilot before cleaning. Before relighting, refer to the lighting instructions in this manual. Instructions are also found on a pull-out panel located on the floor of the appliance.

6. Always keep the appliance area clear and free from combustible materials, gasoline and other flammable liquids.

7. Remember, this appliance has a continuous burning pilot flame. Exercise caution when using products with combustible vapors.

CLEANING AND SERVICING

WARNING: TURN OFF THE UNVENTED GAS ROOM HEATER AND ALLOW TO COOL BEFORE CLEANING.

Only limited cleaning will be required under the normal use of the heater. Dust the front grate, the top of the piezo cover and the control knob occasionally. Do not use cleaning fluids to clean the logs or any other part of the room heater.

Remove the log assembly, gently handling by holding each log at each end. Use a vacuum cleaner to remove loose particles from the base and from around the burners. Gloves are recommended to prevent the fibers from pricking your skin. If the skin is pricked, wash gently with soap and water. Replace the logs as detailed in Step 13 Assembling the Logs.

If, after a period of use, the flames start to exhibit unusual shapes and behavior, or the burners fail to ignite smoothly, then the burner holes may require some cleaning. If this happens, it is preferable to contact your nearest dealer to get the appliance serviced.

REPLACEMENT PARTS

An exploded view of the room heater with numbered parts and a parts list can be found on page 20. All parts should be ordered through your Superior distributor or dealer. Parts will be shipped at prevailing prices at time of order.

When ordering repair parts, always give the following information:

1. The model number of the heater.
2. The serial number of the heater.
3. The part number.
4. The description of the part.
5. The quantity required.
6. The installation date of the heater.

If you encounter any problems or have any questions concerning the installation of this heater, please contact your distributor. For the name of your nearest distributor contact:

SFC
1110 West Taft Avenue
Orange, CA 92865

ACCESSORIES AND COMPONENTS

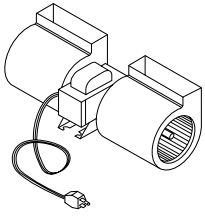

Forced Air Kit FAB-1100

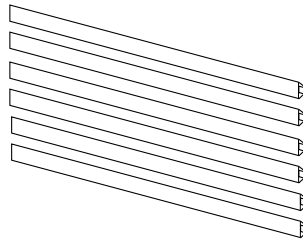

Brass Louver Kit BRLK-5C

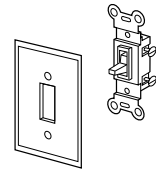

Wall Switch Kit WSK

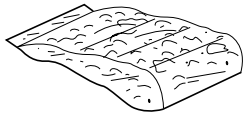

Decorative Volcanic Stone DVS

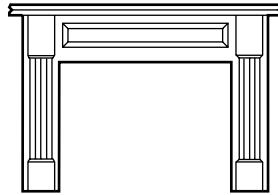

Wood Surround-Wall SUR-5PW

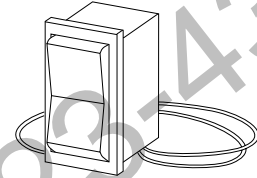

Rocker Switch Kit RS

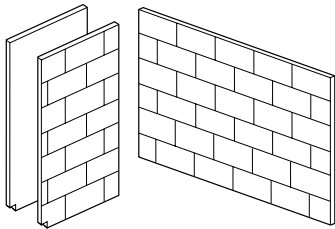

Refractory Liner Kit VFRLK-5

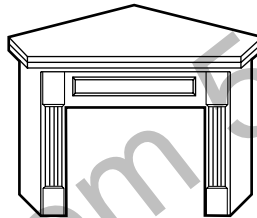

Wood Surround-Corner SUR-5PC

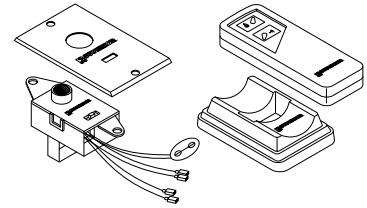

Remote Control Kit RCK

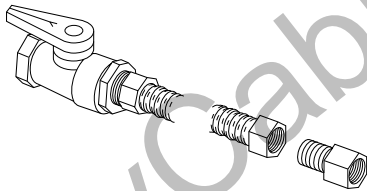

Gas Flex Line Kit GFLV

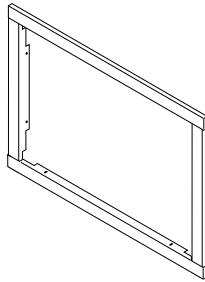

Brass Surround Kit BSK-5

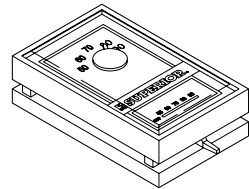

Thermostat WTK

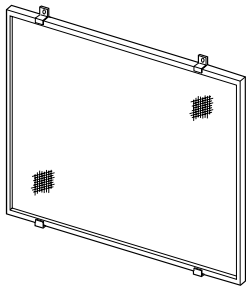

Screen Panel Kit SPK-5

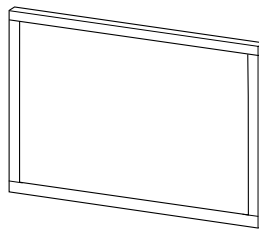

Square Trim Kit STK-5-4

NOTE: DIAGRAMS & ILLUSTRATION NOT TO SCALE.

VF4 SPECIFICATIONS

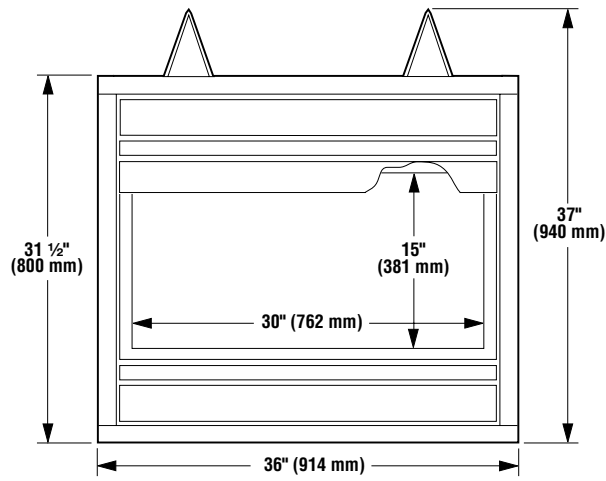

Front View

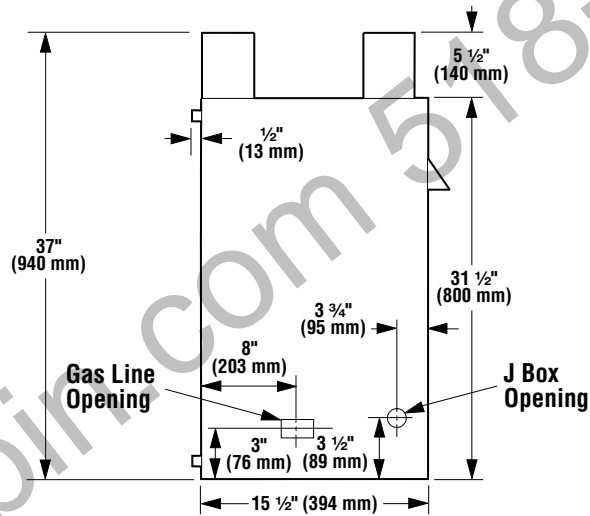

**Left Side View
(Right Side View - Opposite)**

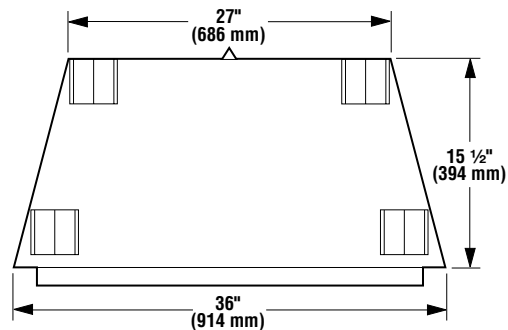

Top View

Figure 22

NOTE: DIAGRAMS & ILLUSTRATION NOT TO SCALE.





VF4-CHM/P OPERATING INSTRUCTIONS (STANDARD VALVES)

FOR YOUR SAFETY READ BEFORE LIGHTING

WARNING: IF YOU DO NOT FOLLOW THESE INSTRUCTIONS EXACTLY, A FIRE OR EXPLOSION MAY RESULT CAUSING PROPERTY DAMAGE, PERSONAL INJURY OR LOSS OF LIFE.

- A.** This heater has a pilot which must be lit by hand. When lighting the pilot, follow these instructions exactly.
- B. BEFORE OPERATING** smell all around the heater area for gas. Be sure to smell next to the floor because some gas is heavier than air and will settle on the floor.
- WHAT TO DO IF YOU SMELL GAS**
- Do not try to light any appliance.
 - Do not touch any electric switch; do not use any phone in your building.
 - Immediately call your gas supplier from a neighbor's phone. Follow the gas supplier's instructions.
 - If you cannot reach your gas supplier, call the fire department.
- C.** Use only your hand to push in or turn the gas control knob. Never use tools. If the knob will not push in or turn by hand, do not try to repair it, call a qualified service technician. Forced or attempted repair may result in a fire or explosion.
- D.** Do not use this heater if any part has been under water. Immediately call a qualified service technician to inspect the appliance and to replace any part of the control system and any gas control which has been under water.

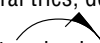
LIGHTING INSTRUCTIONS

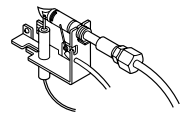
1. Stop! Read the safety information above.
 2. Make sure manual shut-off valve is fully open.
 3. Locate gas control knob and piezo.
 4. Depress control knob in and turn clockwise  to the "OFF" position (Figure 23).
 5. Wait 5 minutes to clear out any gas. Then smell for gas, including near the floor. If you smell gas, **STOP!** Follow "B" in the safety information above. If you do not smell gas, go to the next step.
 6. The pilot is located on the right side in front of the burner (Figure 24).
 7. Depress control knob in and turn counterclockwise  to the "IGN" position (Figure 25). Press the control knob all the way in for 5 seconds.
 8. With the control knob pressed in, push in and release the piezo igniter button to light the pilot.
 9. Hold the control knob in for a further 10 seconds to prevent the flame failure detector from shutting off the gas while the probe is warming up.
 10. Release the control knob while turning counterclockwise  to the "HI" or "LOW" Position.
 - If the knob does not pop out when released, stop and immediately call your service technician or gas supplier.
 - If the pilot will not stay lit after several tries, depress and turn the gas control knob clockwise  to "OFF" and wait 30 seconds. Depress and turn knob counterclockwise  to "IGN" and press igniter button again. If your pilot does not relight depress and turn control knob clockwise  to "OFF" and call your service technician or gas supplier.
 11. Wait 30 seconds before readjusting the heater when the control knob has been turned down to a lower setting.
- 
- Note:** If you are running the heater for the first time it will be necessary to press the control knob all the way in for 30 seconds to allow air to bleed out of the gas piping.

TO TURN OFF GAS TO HEATER

1. Depress and turn control knob clockwise  to the "OFF" position (Figure 23).

MANUAL MATCH LIGHTING PROCEDURE — EMERGENCY ONLY

1. If the pilot cannot be lit with the piezo igniter, the heater can be manually lit with a match.
2. With the right hand, depress and turn the control knob counterclockwise  to the "ON" position. Hold in the knob.
3. Light the match and hold the flame to the end of the pilot and ignite the pilot.
4. Continue to hold control knob for an additional 10 seconds to insure pilot remains lit.
5. Release the control while turning control knob to desired setting.

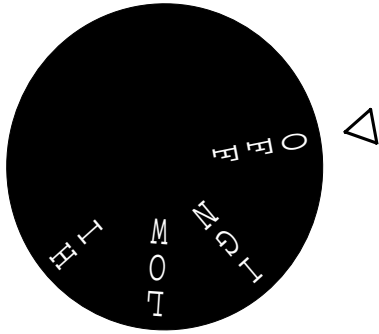

Turn Control Knob to "OFF" Position

Figure 23

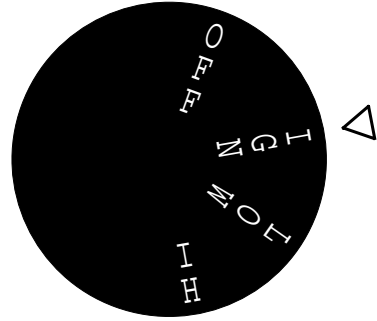

Turn Control Knob to "IGN" Position

Figure 25

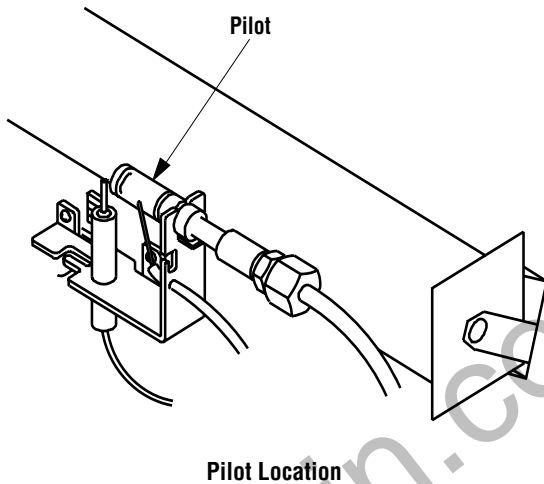

Figure 24







VF4-CMN/P OPERATING INSTRUCTIONS (MILLIVOLT VALVES)

FOR YOUR SAFETY READ BEFORE LIGHTING

WARNING: IF YOU DO NOT FOLLOW THESE INSTRUCTIONS EXACTLY, A FIRE OR EXPLOSION MAY RESULT CAUSING PROPERTY DAMAGE, PERSONAL INJURY OR LOSS OF LIFE.

- A.** This heater has a pilot which must be lit by hand. When lighting the pilot, follow these instructions exactly.
- B. BEFORE OPERATING** smell all around the heater area for gas. Be sure to smell next to the floor because some gas is heavier than air and will settle on the floor.
- WHAT TO DO IF YOU SMELL GAS**
- Do not try to light any appliance.
 - Do not touch any electric switch; do not use any phone in your building.
 - Immediately call your gas supplier from a neighbor's phone. Follow the gas supplier's instructions.
 - If you cannot reach your gas supplier, call the fire department.
- C.** Use only your hand to push in or turn the gas control knob. Never use tools. If the knob will not push in or turn by hand, do not try to repair it, call a qualified service technician. Forced or attempted repair may result in a fire or explosion.
- D.** Do not use this heater if any part has been under water. Immediately call a qualified service technician to inspect the appliance and to replace any part of the control system and any gas control which has been under water.

LIGHTING INSTRUCTIONS

1. Stop! Read the safety information above.
 2. Make sure manual shut-off valve is fully open.
 3. Locate gas control knob and piezo.
 4. Depress control knob in and turn clockwise  to the "OFF" position (Figure 25).
 5. Wait 5 minutes to clear out any gas. Then smell for gas, including near the floor. If you smell gas, **STOP!** Follow "B" in the safety information above. If you do not smell gas, go to the next step.
 6. The pilot is located on the right side in front of the burner (Figure 26).
 7. Depress control knob in and turn counterclockwise  to the "PILOT" position (Figure 27). Press the control knob all the way in for 5 seconds.
 8. With the control knob pressed in, push in and release the piezo igniter button to light the pilot.
 9. Hold the control knob in for a further 10 seconds to prevent the flame failure detector from shutting off the gas while the probe is warming up.
 10. Release the control knob while turning counterclockwise  to the "ON" Position (Figure 28). Then adjust "HI"-"LOW" knob to preferred setting.
 - If the knob does not pop out when released, stop and immediately call your service technician or gas supplier.
 - If the pilot will not stay lit after several tries, depress and turn the gas control knob clockwise  to "OFF" and wait 30 seconds. Depress and turn knob counterclockwise  to "IGN" and press igniter button again. If your pilot does not relight depress and turn control knob clockwise  to "OFF" and call your service technician or gas supplier.
 11. Wait 30 seconds before readjusting the heater when the control knob has been turned down to a lower setting.
- Note: If you are running the heater for the first time it will be necessary to press the control knob all the way in for 30 seconds to allow air to bleed out of the gas piping.*

TO TURN OFF GAS TO HEATER

1. Depress and turn control knob clockwise  to the "OFF" position (Figure 26).

MANUAL MATCH LIGHTING PROCEDURE — EMERGENCY ONLY

1. If the pilot cannot be lit with the piezo igniter, the heater can be manually lit with a match.
2. With the right hand, depress and turn the control knob counterclockwise  to the "ON" position. Hold in the knob.
3. Light the match and hold the flame to the end of the pilot and ignite the pilot.
4. Continue to hold control knob for an additional 10 seconds to insure pilot remains lit.
5. Release the control while turning control knob to desired setting.

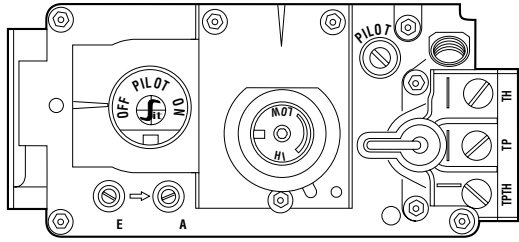

Note: Knob cannot be turned from "PILOT" to "OFF" unless the knob is pushed in slightly. Do not force.

Turn Control Knob to "OFF" Position

Figure 25

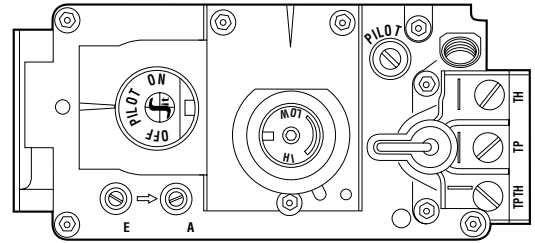

Turn Control Knob to "PILOT" Position

Figure 27

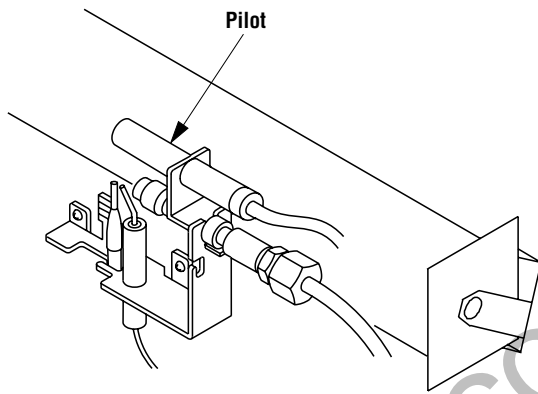

Pilot Location

Figure 26

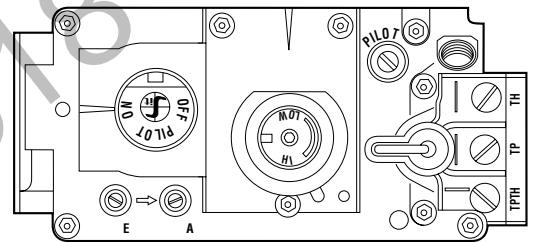

Turn Control Knob to "ON" Position

Figure 28

TROUBLESHOOTING GUIDE FOR UNVENTED GAS PRODUCTS

OBSERVED PROBLEM	POSSIBLE CAUSE	REMEDY
1. When igniter button is pressed, there is no spark at ODS/pilot.	A. Igniter electrode positioned wrong.	Replace igniter.
	B. Igniter electrode broken.	Replace igniter.
	C. Igniter electrode not connected to igniter cable.	Reconnect igniter cable.
	D. Igniter cable pinched or wet.	Free igniter cable if pinched by any metal or tubing. Keep igniter cable dry.
	E. Piezo igniter nut is loose.	Tighten nut.
	F. Broken igniter cable.	Replace igniter cable.
	G. Bad piezo igniter.	Replace piezo igniter.
2. Heater produces unwanted odors.	A. Heater burning vapors from paint, hair spray, glues, etc.	Ventilate room. Stop using odor-causing products while fireplace is running.
	B. Gas leak. See Warning statement on the front page.	Locate and correct all leaks.
3. Heater shuts off in use (ODS operates).	A. Not enough fresh air is available.	Open window and/or door for ventilation.
	B. Low line pressure.	Contact local gas company.
	C. ODS/pilot is partially clogged.	Clean ODS/pilot.
4. Gas odor even when control knob is in "OFF" position.	A. Gas leak. See Warning statement on the front page.	Locate and correct all leaks (see Checking Gas Connections, page 7).
	B. Control valve defective.	Replace control valve.
5. When igniter button is pressed, there is spark at ODS/pilot, but no ignition.	A. Gas supply turned off or manual shut-off valve closed.	Turn on gas supply or open manual shut-off valve.
	B. Control knob not in "PILOT" position.	Turn control knob to pilot position.
	C. Control knob not pressed in while in "PILOT" position.	Press in control knob while in pilot position.
	D. Air in gas lines when installed.	Continue holding down control knob. Repeat igniting operation until air is removed.
	E. ODS/pilot is clogged.	Replace ODS/pilot assembly or get it serviced.
	F. Gas regulator setting is not correct.	Replace gas regulator.
6. ODS/pilot lights, but flame goes out when control knob is released.	A. Control knob not fully pressed in.	Press in control knob fully.
	B. Control knob not pressed in long enough.	After ODS/pilot lights, keep control knob pressed in 30 seconds.
	C. Manual shut-off valve not fully open.	Fully open manual shut-off valve.
	D. Thermocouple connection loose at control valve.	Hand tighten until snug, then tighten ¼ turn more.
	E. Pilot flame not touching thermocouple, which allows thermocouple to cool, causing pilot flame to go out. This problem could be caused by one or both of the following: 1). Low gas pressure 2). Dirty or partially clogged ODS/pilot	1). Contact local gas company. 2). Replace ODS/pilot assembly or get pilot serviced.
	F. Thermocouple damaged.	Replace thermocouple.
	G. Control valve damaged.	Replace control valve.
7. Burner does not light after ODS/pilot is lit.	A. Burner orifice is clogged.	Clean burner or replace burner orifice.
	B. Burner orifice diameter is too small.	Replace burner orifice.
	C. Inlet gas pressure is too low.	Contact local gas company.
8. Delayed ignition of burner.	A. Manifold pressure is too low.	Contact local gas company.
	B. Burner orifice is clogged.	Clean burner or replace burner orifice.
9. Burner backfiring during combustion.	A. Burner orifice is clogged or damaged.	Clean burner or replace burner orifice.
	B. Burner damaged.	Replace burner.
	C. Gas regulator defective.	Replace gas regulator.
10. Slight smoke or odor during initial operation.	A. Vapors from paint or curing process of logs.	Problem will stop after a few hours of operation. SFC recommends running the heater with excess ventilation for the first few hours.
11. Heater produces a whistling noise when burner is lit.	A. Turning control knob to "HI" position when burner is cold.	Turn control knob to "LO" position and let warm up for a minute.
	B. Air in gas line.	Operate burner until air is removed from line. Have gas line checked by local gas company.
	C. Dirty or partially clogged burner orifice.	Clean burner or replace burner orifice.

NOTES:

CozyCabin.com 518-623-4349

REPLACEMENT PARTS LIST

No.	Description	VF4-CHN VF4-CHP		VF4-CMN VF4-CMP	
		Part No.	Qty.	Part No.	Qty.
1.	Valve (Natural)	110331	1	903489	1
	Valve (Propane)	110331	1	901917	1
2.	Injector, Burner (Natural)	110381	2	110381	2
	Injector, Burner (Propane, LPG)	110382	2	110382	2
3.	Pilot (Natural)	110342	1	901914	1
	Pilot (Propane, LPG)	110341	1	901915	1
4.	Regulator (Natural)	110351	1	903218	1
	Regulator (Propane, LPG)	110352	1	112081	1
5.	Front Burner	110281	1	110281	1
6.	Rear Burner (Natural)	110301	1	110301	1
	Rear Burner (Propane, LPG)	113301	1	113301	1
7.	Crossover Burner	110321	1	110321	1
8.	Injector, Crossover Burner (Natural)	110387	1	110387	1
	Injector, Crossover Burner (Propane, LPG)	110388	1	110388	1
9.	Piezo	111061	1	111061	1
10.	Piezo Wire	111361	1	111361	1
11.	Log Assembly	112273	1	112273	1
12.	Bar, Louver-Black	024504	2	024504	2
13.	Panel, Radiant	101391	2	101391	2
14.	Replacement Screen	112721	1	112721	1
	Screen Panel Assembly	112841	1	112841	1
15.	Hood	112751	1	112751	1

REPLACEMENT PARTS

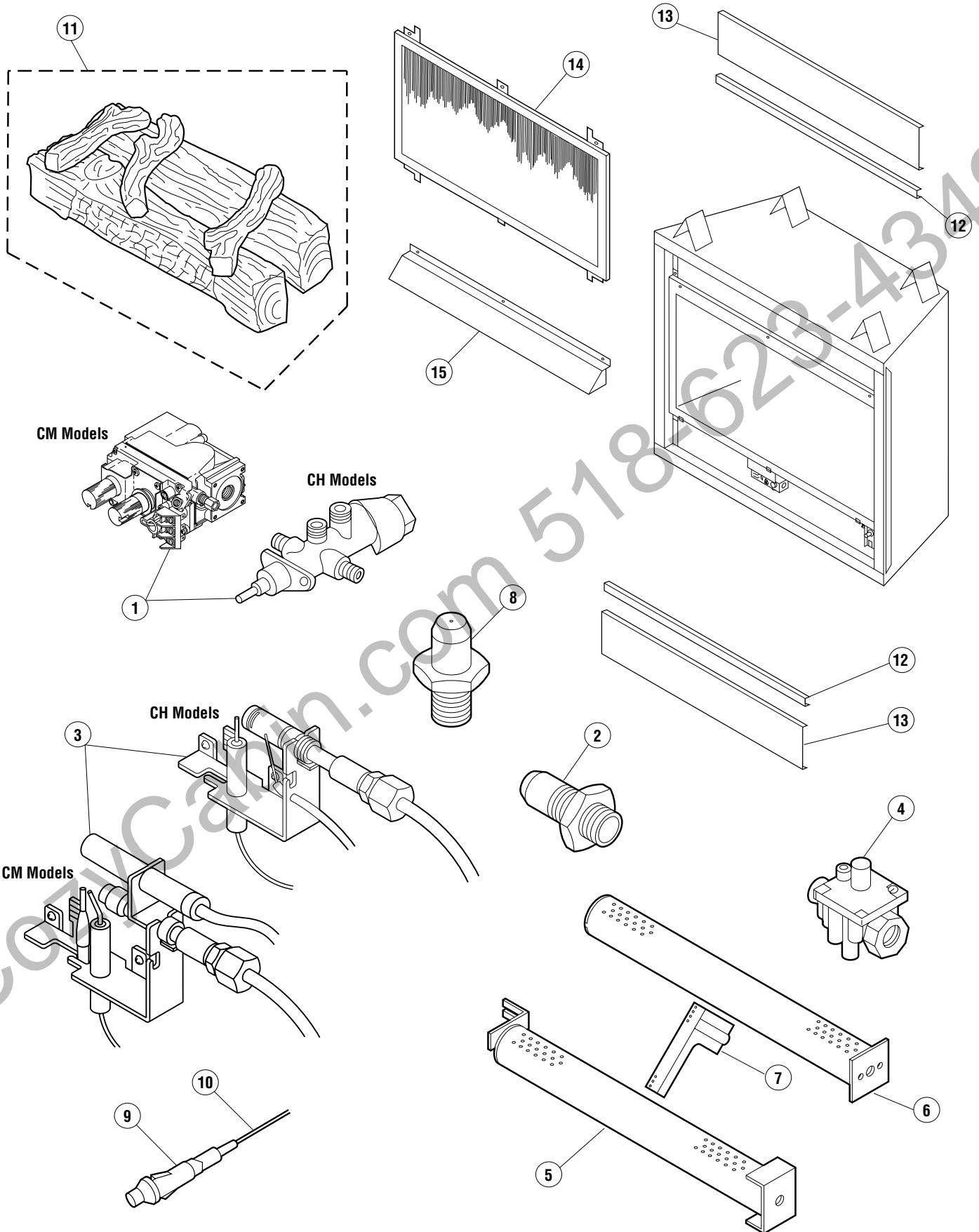

NOTE: DIAGRAMS & ILLUSTRATION NOT TO SCALE.

CozyCabin.com 518-623-4349

CozyCabin.com 518-623-4349

Select Series Unvented Gas Room Heater Limited Lifetime Warranty

THE WARRANTY

Superior Fireplace Company ("SFC") warrants your Select Series Unvented Gas Room Heater ("Product") to be free from defects in materials and workmanship at the time of manufacture. After installation, if any of the components manufactured by SFC in the Product are found to be defective in materials or workmanship during the lifetime of the original owner and while the Product remains at the site of the original installation, SFC will, at its option, replace or repair the defective components at no charge to you. SFC will also pay for reasonable labor costs incurred in replacing or repairing such components for a period of one year from the date of installation. THERE ARE EXCLUSIONS AND LIMITATIONS to this Limited Warranty as described herein.

EXCLUSIONS AND LIMITATIONS

This Limited Warranty applies to the original purchaser, but only if the Product is installed in the United States or Canada and only if installed and operated in accordance with the printed instructions accompanying the Product and in compliance with all applicable installation and building codes and good trade practices. If repair or replacement is not commercially practical, SFC will, at its option, refund the purchase price of the SFC Product.

Vent components, brass components and paint are excluded from this Limited Warranty. The following components are NOT warranted for the lifetime of the original purchaser but are warranted as follows:

- Controls - repair or replacement for one year from the date of installation.
- Logs - repair or replacement for one year from the date of installation.
- Screen - 90 Days from date of installation.

We will not be responsible for: (a) damages caused by accident, riot, fire, flood or acts of God; (b) damages caused by abuse, negligence, misuse, or unauthorized alteration or repair of the Product affecting its stability or performance (The Product must be subject to normal use. The Product is designed to burn either natural or propane gas only. Burning conventional fuels such as wood, coal or any other solid fuel will cause damage to the Product, will produce excessive temperatures and will result in a fire hazard); (c) damages caused by failing to provide proper maintenance and service in accordance with the instructions provided with the Product; (d) damages, repairs or inefficiency resulting from faulty installation or application of the Product.

This Limited Warranty covers only parts and labor as provided herein. In no case shall SFC be responsible for materials, components or construction which are not manufactured or supplied by SFC or for the labor necessary to install, repair or remove such materials, components or construction. The use of components manufactured by others with this SFC Select Series Unvented Gas Room Heater could create serious safety hazards, may result in the denial of certification by recognized national safety agencies, and could be in violation of local building codes. All replacement or repair components will be shipped F.O.B. the nearest SFC factory.

LIMITATION ON LIABILITY

It is expressly agreed and understood that SFC's sole obligation and purchaser's exclusive remedy under this warranty, under any other warranty, expressed or implied, or in contract, tort or otherwise, shall be limited to replacement, repair, or refund, as specified herein.

In no event shall SFC be liable for any incidental or consequential damages caused by defects in the Products, whether such damage occurs or is discovered before or after replacement or repair, and whether such damage is caused by SFC's negligence. SFC has not made and does not make any representation or warranty of fitness for a particular use or purpose, and there is no implied condition of fitness for a particular use or purpose.

We make no express warranties except as stated in this Limited Warranty. The duration of any implied warranty is limited to the duration of this expressed warranty.

No one is authorized to change this Limited Warranty or to create for us any other obligation or liability in connection with the Product. Some states and provinces do not allow the exclusion or limitation of incidental or consequential damages, so the above limitations or exclusions may not apply to you. The provisions of this Limited Warranty are in addition to and not a modification of or subtraction from any statutory warranties and other rights and remedies provided by law.

INVESTIGATION OF CLAIMS AGAINST WARRANTY

SFC reserves the right to investigate any and all claims against this Limited Warranty and to decide upon method of settlement.

SFC NOT RESPONSIBLE FOR WORK DONE WITHOUT WRITTEN CONSENT

To receive the benefits and advantages described in this Limited Warranty, the appliance must be installed and repaired by a licensed contractor approved by SFC. Contact SFC at the address provided herein to obtain a listing of approved dealers. SFC shall in no event be responsible for any warranty work done by a contractor that is not approved without first obtaining SFC's prior written consent.

HOW TO REGISTER A CLAIM AGAINST WARRANTY

In order for any claim under this Warranty to be valid, SFC must be notified of the claimed defect in writing as soon as reasonably possible after the defect is discovered. Notices should be directed to SFC, attention Customer Service Department, 1110 West Taft Avenue, Orange, CA 92865. Claims in writing should include the date of installation and a description of the defect.

SFC reserves the right to make changes at any time, without notice, in design, materials, specifications, prices and also to discontinue colors, styles and products. Consult your local distributor for fireplace code information.