

Vermont Castings Pinnacle Direct Vent Gas Heater PDV20

Homeowner's Installation and Operation Manual

Includes Installation, Operation and Maintenance Procedures for using the PDV20 Firebox with the Pinnacle Hearthmount and the Stardance (SDVR) Freestanding Stove Shells

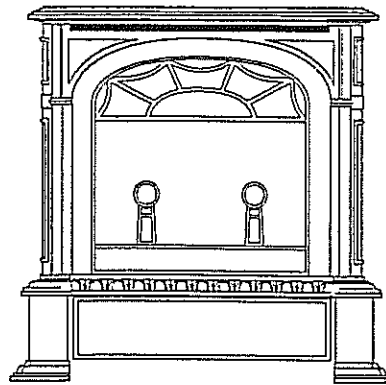

Tested and Listed to ANSI
Z21.88-1998 and CSA-2.33-M98

WARNING

If you do not follow these instructions exactly, a fire or explosion may result causing property damage, personal injury or loss of life.

FOR YOUR SAFETY:

Do not store or use gasoline or other flammable vapors and liquids in the vicinity of this or any other appliance.

WHAT TO DO IF YOU SMELL GAS

- Shut off the gas supply.
 - Open windows; do not touch any electrical switches.
 - Do not try to light any appliance; extinguish any open flame.
 - Do not use the phone in your building.
 - Immediately call your gas supplier from a neighbor's phone.
- Follow the gas supplier's instructions.
- If you cannot reach your gas supplier, phone the fire department.

Installation and service must be performed by a qualified installer, service agency or the gas supplier.

**SAVE THIS MANUAL FOR
FUTURE REFERENCE.**

AVERTISSEMENT

Quiconque ne respecte pas à la lettre les instructions dans le présent manuel risque de déclencher un incendie ou une explosion entraînant des dommages matériels, des lésions corporelles ou la perte de vies humaines.

POUR VOTRE SÉCURITÉ:

Ne pas entreposer ni utiliser d'essence ni d'autre vapeurs ou liquides inflammables dans le voisinage de cet appareil ou de tout autre appareil.

QUE FAIRE SI VOUS SENTEZ UNE ODEUR DE GAZ:

- Fermer le gaz alimentation.
- Ne pas tenter d'allumer d'appareil.
- Ne touchez à aucun interrupteur. Ne pas vous servir des téléphones se trouvant dans le bâtiment où vous trouvez.
- Evacuez la pièce, le bâtiment ou la zone. Appelez immédiatement votre fournisseur de gaz depuis un voisin. Suivez les instructions du fournisseur.
- Si vous ne pouvez rejoindre le fournisseur de gaz, appelez le service des incendies.

L'installation et service doit être exécuté par un qualifié installer, agence de service ou le fournisseur de gaz.

The Pinnacle Direct Vent Room Heater, Model #PDV20, No. 2938 and 2939, is a vented gas appliance listed to the ANSI standard Z21.88-1998 and CSA-2.33-M98 for Vented Room Heaters, and CAN/CGA 2.17-M91, Gas-Fired Appliances For Use at High Altitudes.

This installation must conform with local codes, or in the absence of local codes, with National Fuel Gas Code, ANSI Z223.1 — latest edition, or the Canadian Installation Code, CAN/CGA B149. Installer l'appareil selon les codes ou règlements locaux, ou, en l'absence de tels règlements, selon les Codes D'Installation CAN/CGA-B149 (EXCEPTION: Do not derate this appliance for altitude. Maintain the manifold pressure at 3.5 inches W.C. for Natural Gas and 11 inches W.C. for LP gas at maximum input.)

This appliance is only for use with the type of gas indicated on the rating plate. This appliance is not convertible for use with other gases unless a certified kit is used.

Installation and replacement of gas piping, gas utilization equipment or accessories, and repair and servicing of equipment shall be performed only by a qualified agency. The term "qualified agency" means any individual, firm, corporation, or company that either in person or through a representative is engaged in and is responsible for (a) installation or replacement of gas piping, or (b), the connection, installation, repair, or servicing of equipment, who is experienced in such work, familiar with all precautions required, and has complied with all the requirements of the authority having jurisdiction.

The Pinnacle Direct Vent Room Heater should be inspected before use and at least annually by a qualified service agency. More frequent cleaning may be required due to excessive lint from carpeting, bedding material, etc. It is imperative that control compartments, burners, and circulating air passageways of the appliance be kept clean. S'assurer que le brûleur et le compartiment des commandes sont toujours propres. Voir les instructions d'installation qui accompagnent l'appareil.

The Pinnacle Direct Vent Room Heater and its individual shut-off valve must be disconnected from the gas supply piping during any pressure testing of that system at test pressures in excess of 1/2 psig (3.5 kPa).

The Pinnacle Direct Vent Room Heater must be isolated from the gas supply piping system by closing its individual manual shutoff valve during any pressure testing of the gas supply piping system at test pressures equal to or less than 1/2 psig.

A 1/8-inch N.P.T. plugged tapping, accessible for test gage connection, should be installed on the inlet gas connection.

'Direct Vent' describes a sealed combustion system in which incoming outside air for combustion and outgoing exhaust enter and exit through two separate concentric passages within the same sealed vent system. The system does not use room air to support combustion. The direct vent system permits the gas appliance to be vented directly to the outside atmosphere through the side of the house, unlike conventional venting systems that take air from the room for combustion and vent the exhaust vertically through the roof to the atmosphere.

This appliance is approved for bedroom installations in the U.S. and Canada.

This appliance may be installed in an aftermarket* manufactured (mobile) home, where not prohibited by state or local codes.

WARNING: Operation of this heater when not connected to a properly installed and maintained venting system can result in carbon monoxide (CO) poisoning and possible death.

The Pinnacle Direct Vent Room Heater, when installed, must be electrically grounded in accordance with local codes or, in the absence of local codes, with the National Electrical Code ANSI/NFPA 70, (latest edition), or of the current Canadian Electrical Code C22.1.

Due to high temperatures this appliance should be located out of traffic and away from furniture and draperies.

WARNING: This appliance is hot while in operation. Keep children, clothing, and furniture away. Contact may cause burns or ignition of combustible materials.

Children and adults should be alerted to the hazards of high surface temperatures and should stay away to avoid burns or clothing ignition. Young children should be carefully supervised when they are in the same room as the appliance.

Clothing or other flammable materials should not be placed on or near the appliance. Surveiller les enfants. Garde les vêtements, le meubles, l'essence ou autres liquides a vapeur inflammables lin de l'appareil.

Any safety screen or guard removed for servicing an appliance must be replaced prior to operating the appliance.

The appliance area must be kept clear and free from combustible materials, gasoline, and other flammable vapors and liquids.

The flow of combustion and ventilation air must not be obstructed. The installation must include adequate accessibility and clearance for servicing and proper operation.

WARNING: Do not operate the Room Heater with the glass panel removed, cracked or broken. Replacement of the panel should be done by a licensed or qualified service person.

Do not use this appliance if any part has been under water. Immediately call a qualified service technician to inspect the appliance and to replace any part of the control system and any gas control which has been under water.

Do not burn wood, trash or any other material for which this appliance was not designed. This appliance is designed to burn either natural gas or propane only.

This gas appliance must not be connected to a chimney flue serving a separate solid-fuel burning appliance.

CAUTION: Label all wires prior to disconnection when servicing controls. Wiring errors can cause improper and dangerous operation.

Verify proper operation after servicing.

* Aftermarket: Completion of sale, not for purpose of resale, from the manufacturer.

Table of Contents

General Information	2
Specifications	4
Installation Requirements	6
Fireplace Installations	8
Horizontally-terminated Installations	10
Vertically-terminated Installations	14
Assembly Procedures	15
Operation	29
Troubleshooting	32
Maintenance	33
Wiring Diagrams	36
Parts Diagram and List	37
Appendix: Stardance Shell Installation (SDVR)	39
Warranty	43

Specifications

Pinnacle PDV20 Direct Vent Gas Heater / NG 2938 and LP 2939

Fuel	NG	LP
Manifold Pressure - Min. / Max	1.7" / 3.5"	5.4" / 11.0"
Inlet Supply Pressure for adjustment - Min. / Max.	5.0" / 11.0"	1.0" / 13.0"
Input, BTU/hr. - Min. / Max.	14,000 / 20,000	14,000 / 20,000
A.F.U.E:	65.9%	67.9%
Steady State *	66.7%	68.7%
Ignition: Standing pilot with piezo ignition		
Weight: 200 lbs.		
Minimum Fireplace Opening Height: See Below		
* seasonal efficiency – minimum vent, no fan		

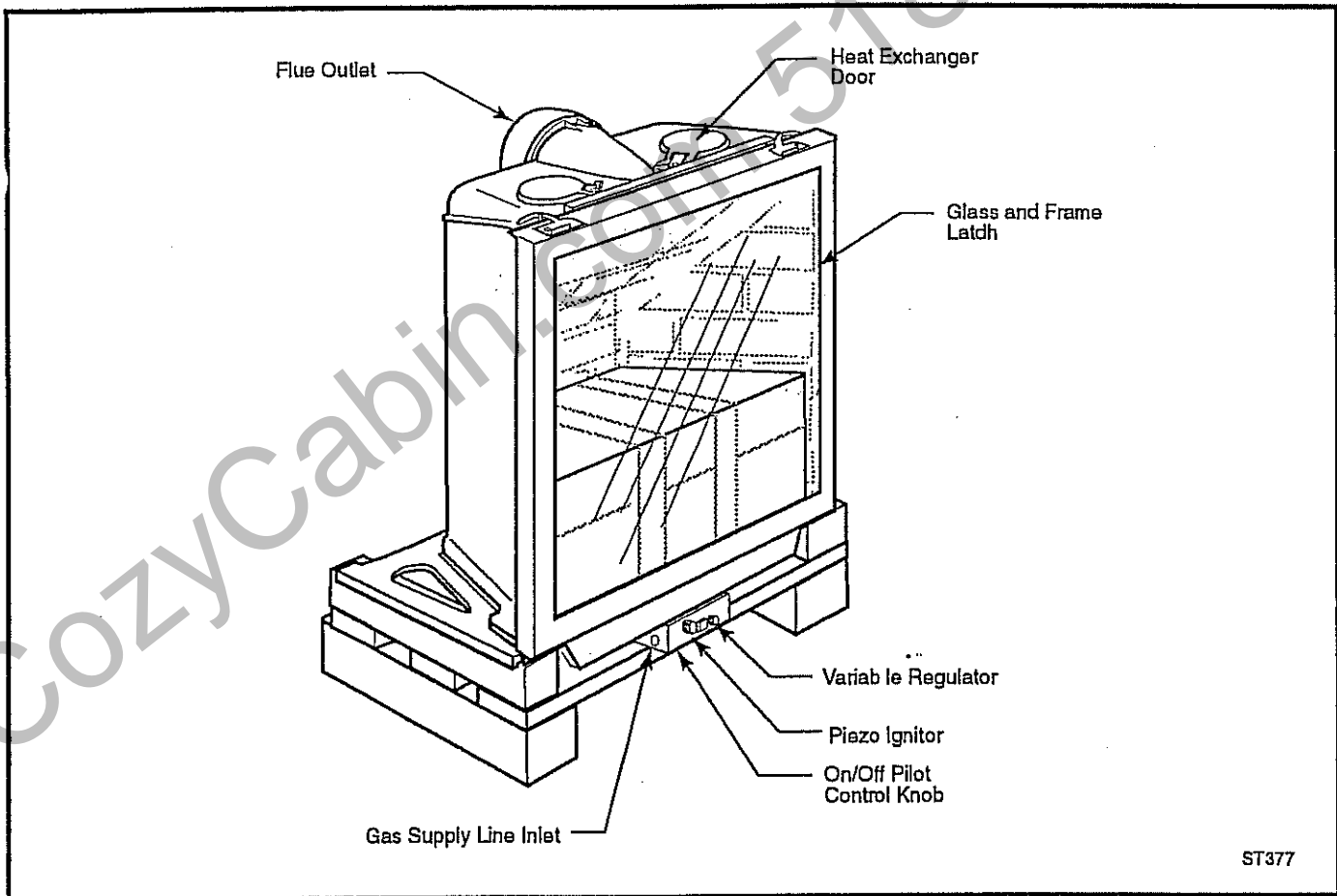
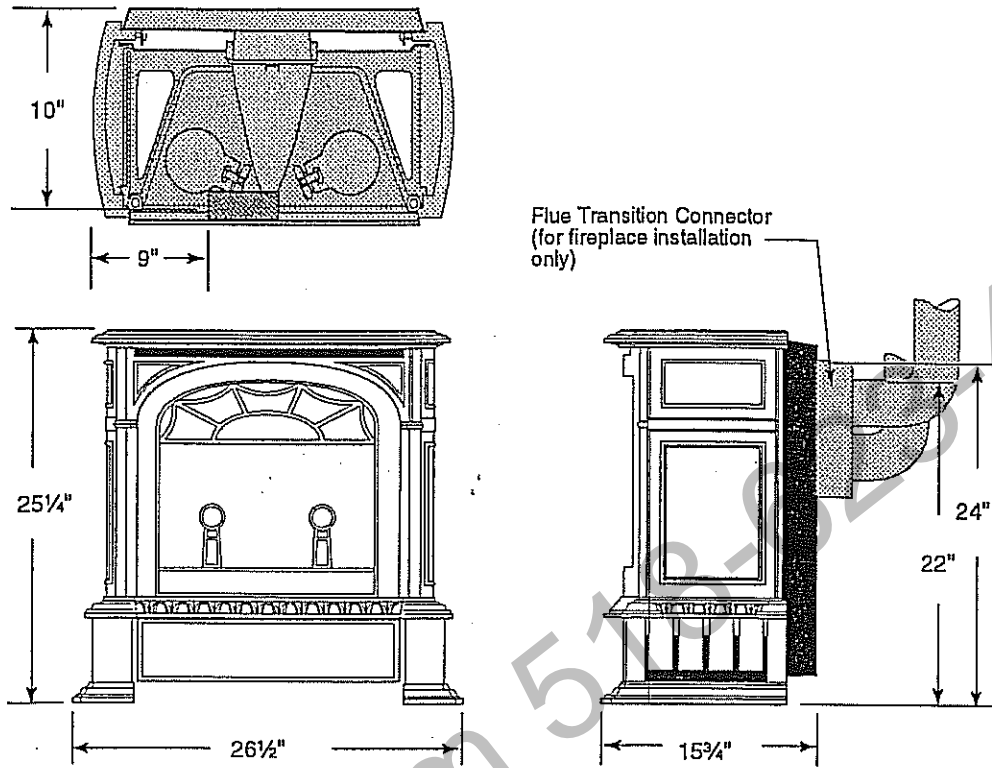

Fig. 1 The PDV20 firebox.

Pinnacle PDV20 Dimensions



0089

Fig. 2 Pinnacle PDV20 specifications.

Fireplace Installation Requirements

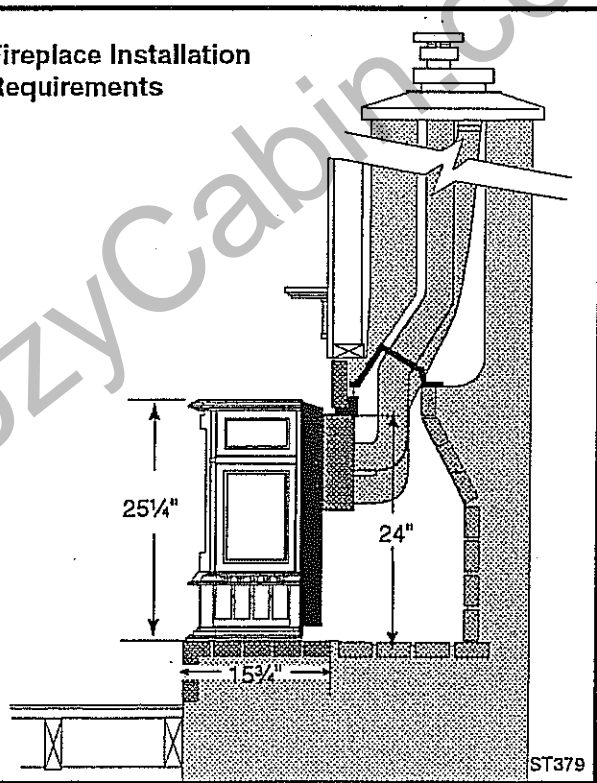

Fig. 3 Minimum lintel height for flush placement.

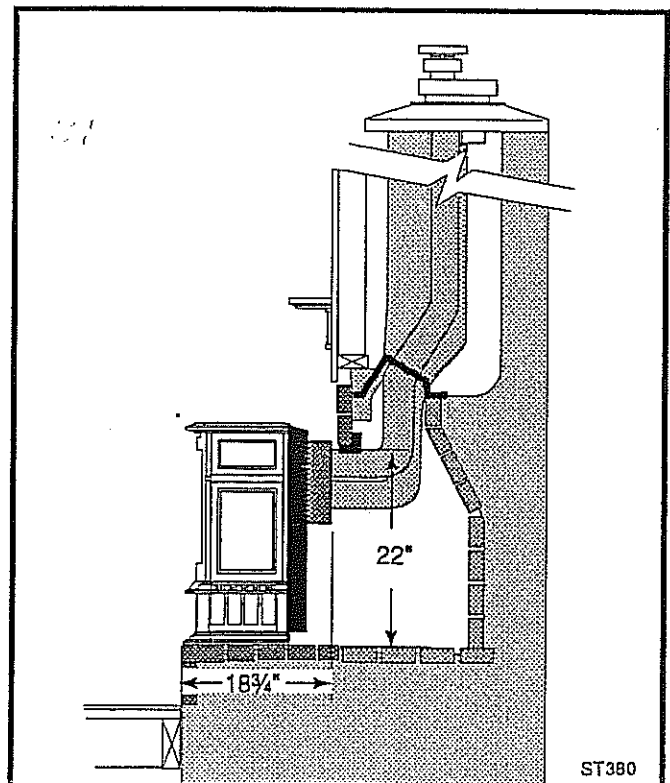

Fig. 4 Minimum lintel height, for forward placement.

Installation Requirements

Installation options for the Pinnacle PDV20 Direct-Vent Gas Heater include 'hearthmount' installations (in front of a fireplace), with the venting system passing through a fireplace flue, and 'direct-vent' installations, with a concentric venting system passing through an exterior wall or roof to the outdoors. Never connect this appliance to a vent or flue system serving another appliance.

Hearth Requirements

The PDV20 must be installed on rigid flooring. When the heater is installed directly on any combustible surface other than wood flooring, a metal or wood panel extending the full width and depth of the unit must be used as the hearth. There are no other hearth requirements.

Keep the Stove a Safe Distance from Surrounding Materials

The PDV20 will heat nearby surfaces when operating. A safe installation requires that adequate clearance be maintained between the stove and nearby combustible materials to ensure that such materials do not overheat. The diagrams that follow illustrate the minimum clearances for the appliance in parallel, corner, and alcove installations.

For further information on ventilation guidelines and sizing specifications follow the National Fuel Gas Code NFPA 54/ANSI Z223.1 Section 5.3.

Fireplace Size Requirements

See Figure 2 on page 4 for the fireplace opening requirements relevant to your particular installation.

Minimum Clearances to Combustible Materials

Maintain clearance (empty space) between combustible materials and the heater as specified in the following diagrams.

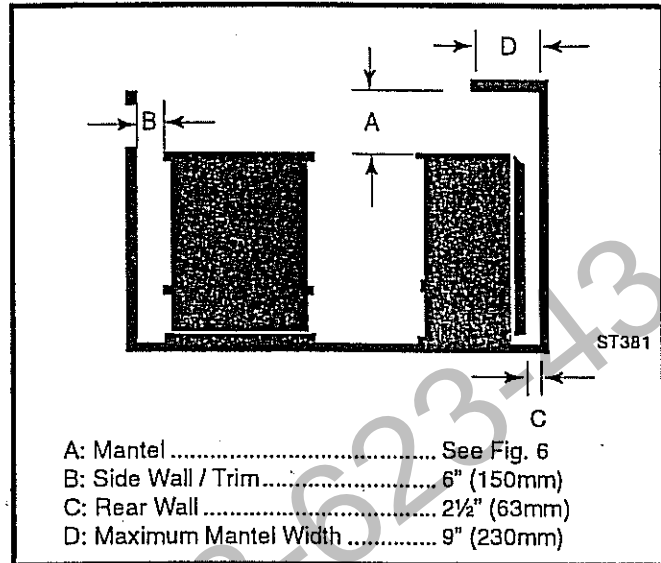

Fig. 5 Minimum clearance for PDV20.

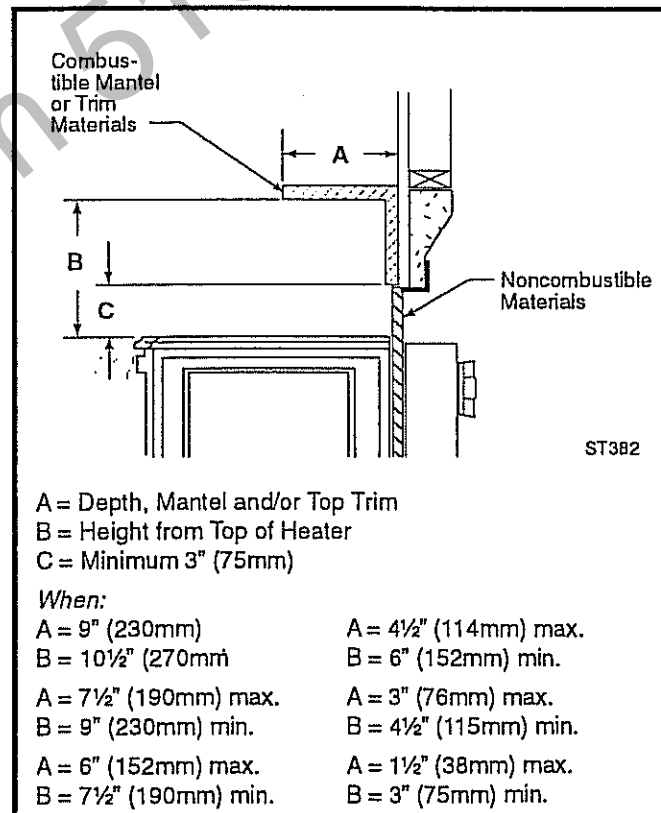

Fig. 6 Mantel / top trim clearances.

Freestanding Installation Clearances

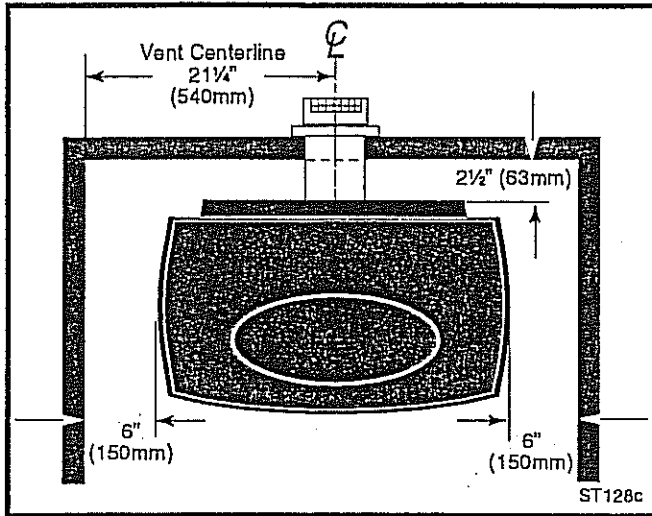

Fig. 7 Freestanding parallel installation; minimum clearances.

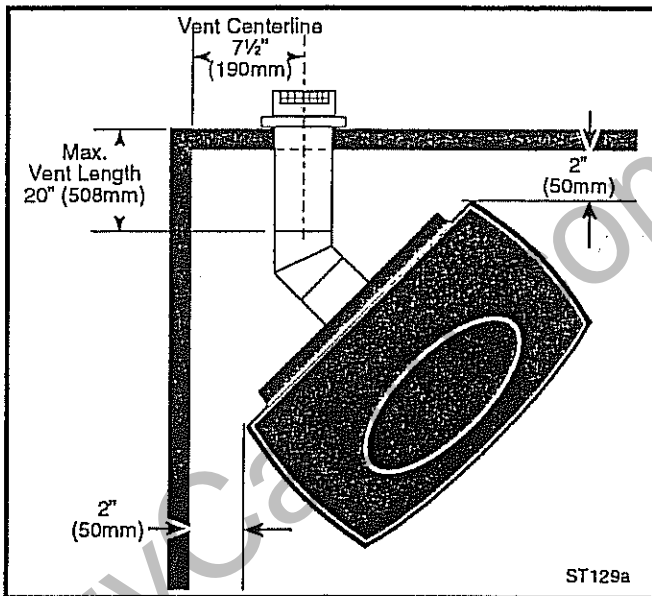

Fig. 8 Freestanding corner installation; minimum clearances.

Venting Clearance

Minimum clearance between vent pipes and combustion materials is 1" (25mm) on top, sides and bottom, unless otherwise noted.

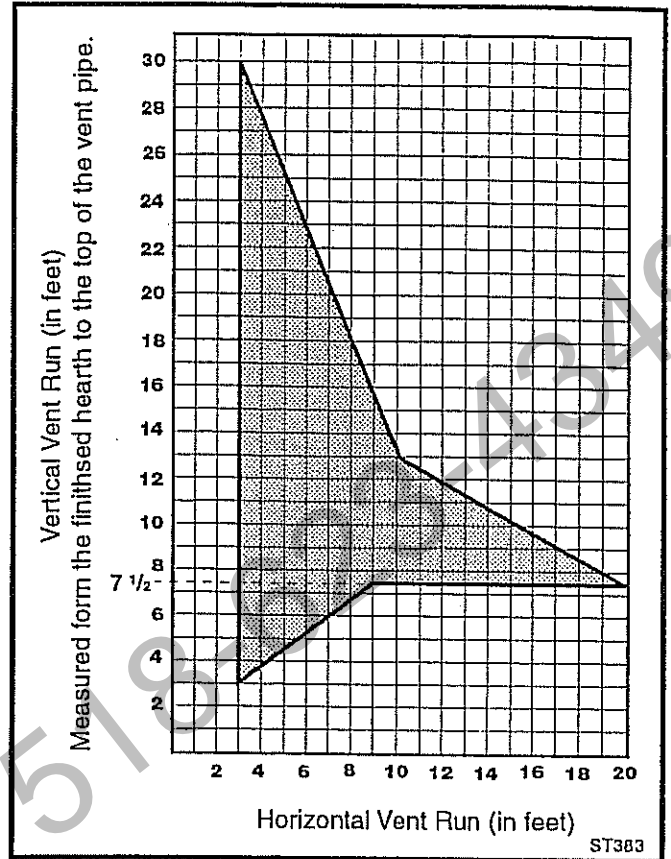

Fig. 9 Vent window for horizontally-terminated installation that include a vertical rise.

Venting Limits

- When a vertical run is required, the first elbow must be installed immediately off of the stove.
- Any installation that does not terminate immediately behind the stove, must terminate within the shaded area in Figure 9 above. Example: If the horizontal run is 9 feet (274 cm), the termination must be at least 7½ feet (229 cm) high.
- The maximum horizontal vent length is 20 feet (610 cm) when the vertical rise is 7½ feet (229 cm).
- The maximum horizontal run straight from the stove to the sidewall termination is 20" (508 mm). (Fig. 12)
- Locate the heater to minimize the horizontal vent length and number of elbows.

Venting Requirements and Options

The PDV20 Heater must be vented to the outdoors through an existing masonry or prefabricated fireplace, through an adjacent exterior wall, or through the roof.

Approved Vent System Components for Fireplace Installations

The PDV20 Heater is approved to be vented to the outdoors through any solid-fuel fireplace that has been constructed or installed in accordance with the National, Provincial/State and local building codes and is constructed of noncombustible materials. Use the following approved CFM/Majestic vent components for fireplace installations vented through a masonry chimney:

Component

7TFSCSK	Transition Connector
HEDV25	25-foot flex connector (two 25-foot sections)
HEDV35	35-foot flex connector (two 35-foot sections)
HEDV32T812	Vent termination for 8 x 12" flue
HEDV32T1212	Vent termination for 12 x 12" flue

- The maximum horizontal offset is 2 feet (601 mm).

Fireplace Vent Terminus Clearances

Observe the chimney-top vent terminus clearances specified in the instructions provided with those components. Some considerations are:

- Obstructions or impediments to venting.
- Nearby combustible materials that could come into contact with combustion exhaust gases.
- Other nearby openings (within 9" (230mm) through which exhaust gas could re-enter the building.
- All vegetation within 3 feet (.9m) that may interfere with the draft.

Fireplace Venting Requirements

- The PDV20 requires a **minimum vent run of 12 feet (4.2m)**, measured from the hearth to the discharge opening at the termination.
- The **maximum vertical run is 35 feet (10.7m)** measured from the hearth to the discharge opening at the termination.

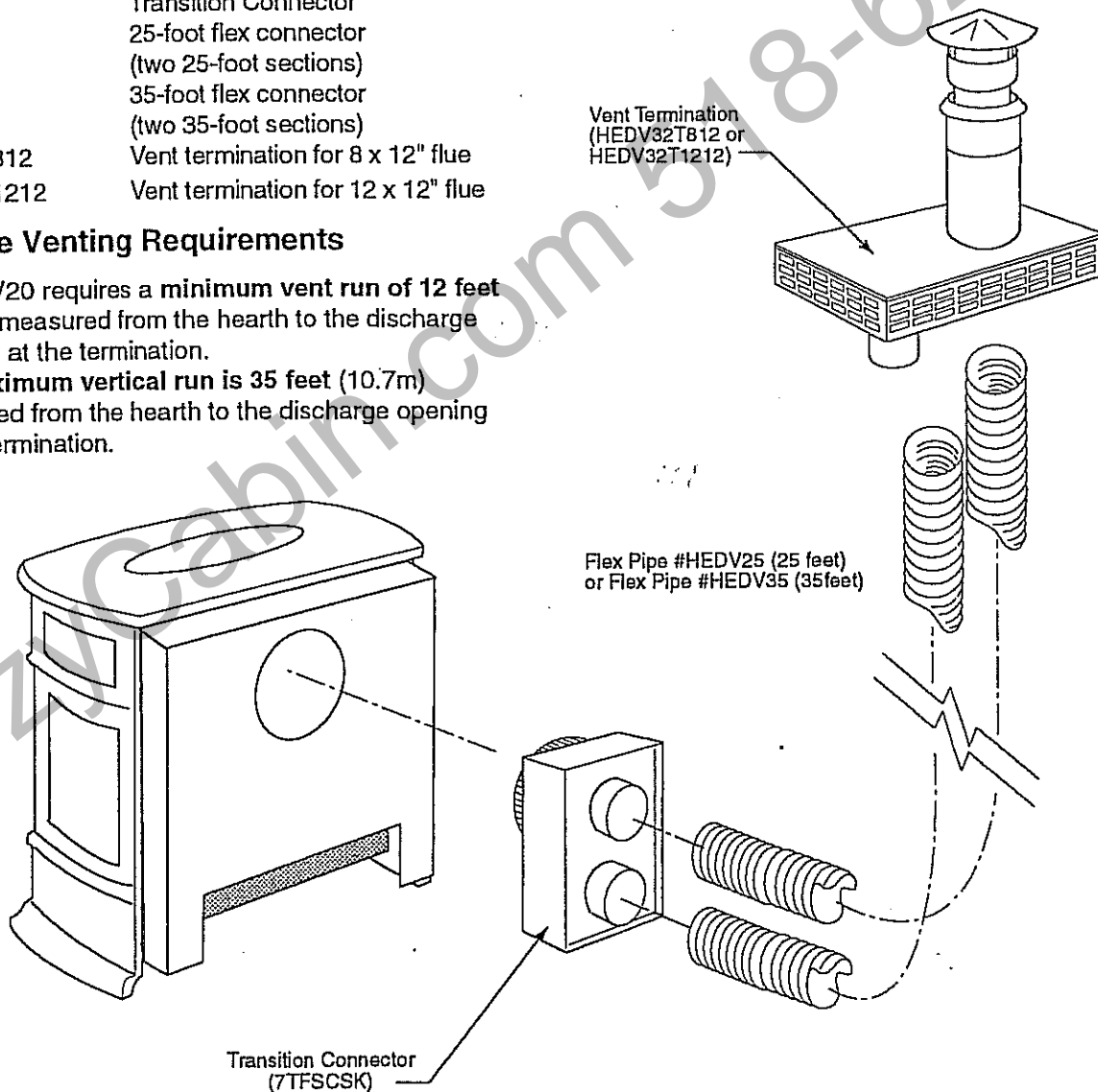

Fig. 10 Vent components for fireplace installations.

Approved Vent System Components for Through-Wall and Through-Roof Installations

The venting system must be comprised of the appropriate CFM/Majestic venting components. These parts are available from your PDV20 dealer. All pipe has a 7" outer diameter and includes a 4" diameter inner section. A (CG) designation indicates that the part is finished in Charcoal Gray paint. Consult your dealer about other CFM vent parts that may be appropriate to complete the installation.

An inner adaptor pipe is included with the heater, for use in all installations.

Use Rear Vent Kit 7TFSRSK for an installation where the heater is parallel to the wall and the vent system extends straight back through that wall.

Rear Vent Kit 7TFSRSK

- 1, 20" Starter pipe (CG) for through wall installation
- 1, Side Wall Termination
- 1, Firestop
- 1, Wall plate (CG)
- 1, Finishing Collar (CG)
- 1, Zero-clearance sleeve
- 1, Hardware Package

Minimum Side Wall Vent Kit* 7TFSMSK

- 1, 90° Elbow (CG)
 - 1, 24" Starter pipe (CG) for through wall installation
 - 1, 24" Straight pipe (CG)
 - 1, Side Wall Termination
 - 1, Zero-clearance sleeve
 - 1, Wall Plate (CG)
 - 1, Finishing Collar (CG)
 - 1, Firestop
 - 1, Hardware Package
 - 4, Polished Brass Pipe Rings
- * Add one #7TDVRT90 elbow to this kit for PDV20 installations.

Sidewall Starter Kit 7TFSVSK

- 1, 90° Elbow (CG)
- 1, Firestop
- 1, Finishing Collar (CG)
- 1, 48" straight pipe
- 1, Sidewall Termination
- 1, Wall Plate (CG)
- 1, 24" Starter pipe
- 1, Zero-clearance Sleeve

Minimum Horizontal Vent Kit for Below Grade Termination 7TFSVSKS

Includes all of the above parts plus 1, Snorkel Termination

Vertical Termination Kit, 1/12–6/12 Pitch 7TDVSKVA

- 1, Combination Horizontal Offset / Roof Support
- 1, Vertical Termination
- 1, 1/12 - 6/12 Flashing
- 1, Polished Brass Flue Pipe Ring
- 1, Storm Collar
- 1, Finishing Collar [CG]
- 1, Hardware Package

Vertical Termination Kit, 7/12–12/12 Pitch 7TDVSKVB

- 1, 7/12 - 12/12 Flashing
- and all of the other Vertical Termination parts

Vertical Termination, Flat Roof 7TDVSKVF

- 1, Flat Flashing and all of the other Vertical Termination parts

Twist Lock 24" Straight Pipe [CG] 7TFSDVP24

- 1, 24" Non-adjustable Pipe
- 1, Polished Brass Flue Pipe Ring

Twist Lock 48" Straight Pipe [CG] 7TFSDVP48

- 1, 48" Non-adjustable Pipe
- 1, Polished Brass Flue Pipe Ring

Twist Lock 45 Degree Elbow [CG] 7TFS45

- for vertical offsets
- 1, 45 Degree Elbow
- 1, Polished Brass Flue Pipe Ring

Siding Shield 7DVSS

Combination Offset/Roof Support 7DVCS

Attic Insulation Shield 7DVAIS

90° Elbow, (CG) 7TFS90

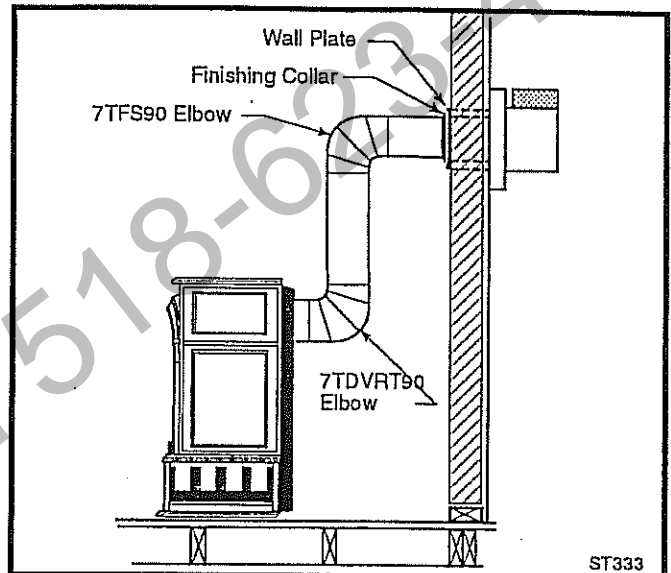

Fig. 11 PDV20 Heater with Vent Kit 7TFSMSK and additional 7TDVRT90 elbow.

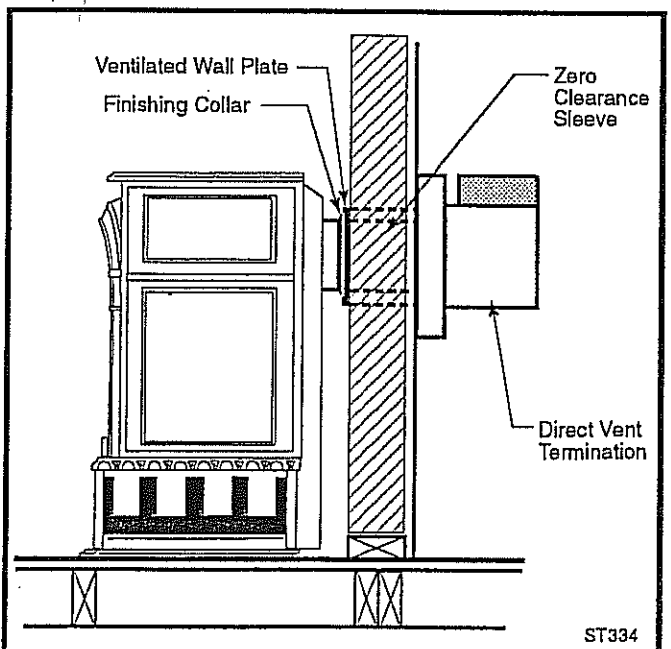

Fig. 12 Side View. PDV20 Heater with Rear Vent Kit 7TFSRSK. Maximum horizontal run may be 20" (508mm).

Sidewall Venting Installations

it is very important that the venting system maintain its balance between the combustion air intake and flue gas exhaust. The installation must meet certain limits as to vent configuration. Figure 12 on Page 9 shows the minimum vent layout for a straight-back installation, with the heater parallel to the exterior wall.

The graph in Figure 9 showing the relationship between vertical and horizontal venting will determine the vent lengths allowable.

It is always best to locate the heater to require the minimum possible horizontal vent length and number of offsets. The maximum allowable turns in the vent system equal 270 degrees; see Figure 13 for an example.

- When the vent termination exits through a foundation less than 20" below a siding outcrop, the vent pipe must flush up with the siding. The installation must also include a siding shield, #7DVSS.
- The horizontal vent run refers to the total length of vent pipe from the flue collar of the heater to the face of the exterior wall.
- 'Horizontal plane' means no vertical rise exists on this part of the vent assembly.
- Any vent system that includes a vertical run must begin with a vertical run directly off the appliance.

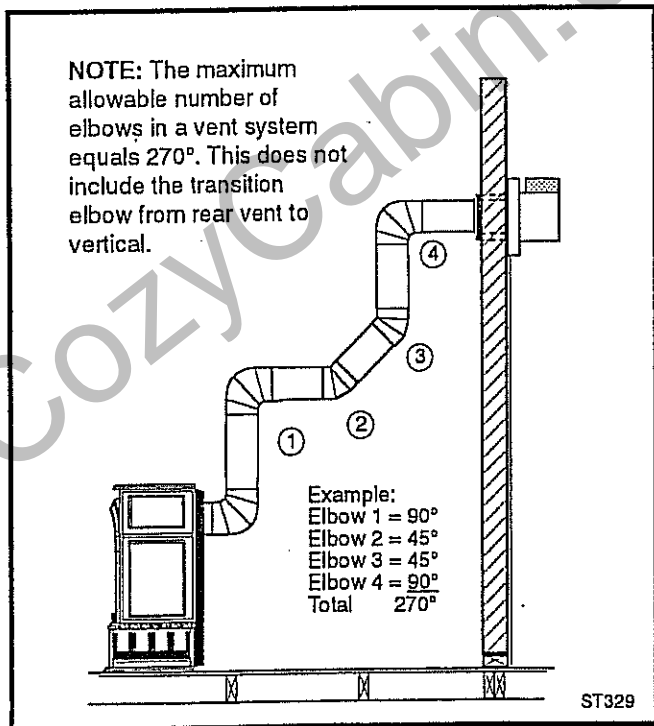

Fig. 13 Maximum elbow configuration.

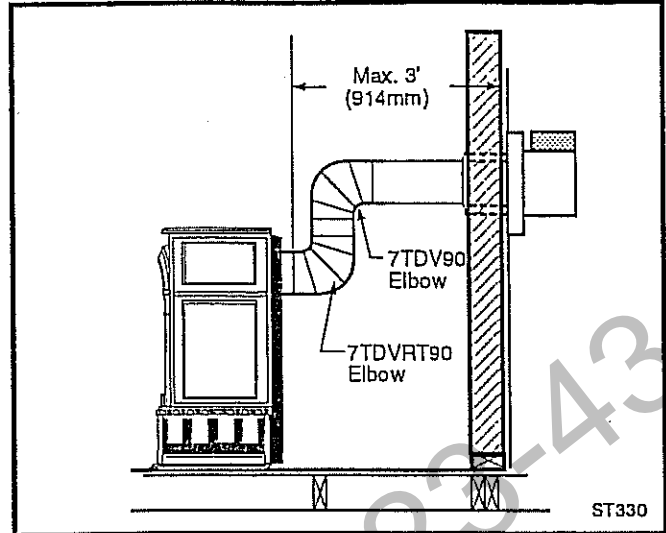

Fig. 14 Maximum horizontal vent in this layout is 3'.

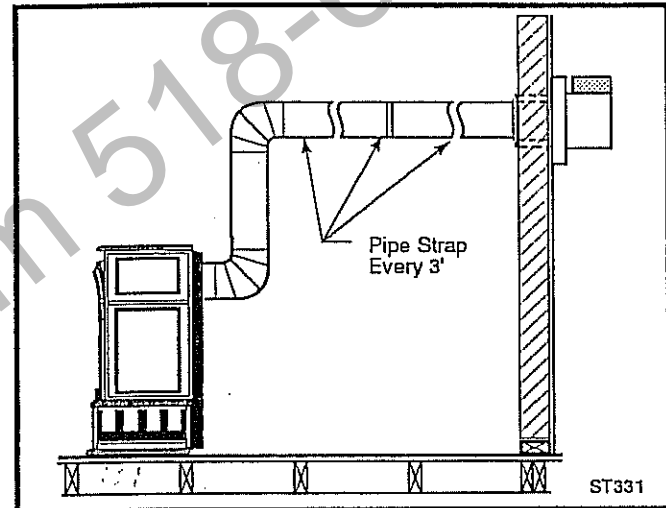

Fig. 15 Use pipe straps to support horizontal runs of vent pipe.

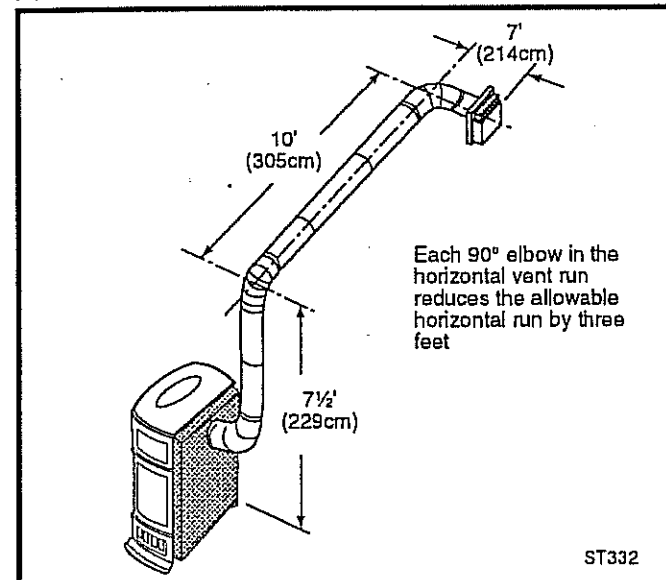

Fig. 16 Maximum horizontal vent configuration.

Vent Terminus Clearances

When planning the installation, consider the location of the vent terminal and clearances. Some of the most common clearances to keep in mind are shown in Figure 18.

Important: all vent clearances must be maintained. Check your vent Terminus clearances against Figs. 18-20

The vent should be placed so that people cannot be burned by accidentally touching the vent surfaces when the stove is operating.

The vent termination should be located where it cannot be damaged by such things as automobile doors, lawn mowers or snowblowers and it should be located away from areas where it could become blocked by snow, etc.

Some considerations are:

- Obstructions or impediments to venting.
- Nearby combustible materials that could come into contact with combustion exhaust gases.
- Other nearby openings (within 9" (230mm)) through which exhaust gas could re-enter the building.
- All vegetation within 3' (.9m) that may interfere with the draft.
- **Vinyl siding requires protection from vented heat immediately above the vent opening. Use Vinyl Siding Shield #7DVSS.** The shield is also recommended for installations on combustible siding.

Other factors that influence where the installation will be sited include the location of outside walls, where additional heat may be desired in the home, where the family members gather most regularly, and perhaps most importantly, the distance limitations of the venting system.

 **WARNING**

- Always maintain required clearances (air spaces) to nearby combustibles to prevent fire hazard. Do not fill air spaces with insulation. All venting components must maintain a 1" (25mm) clearance to combustible materials.
- The gas appliance and vent system must be vented directly to the outside of the building and never be attached to a chimney serving a separate solid fuel or gas-burning appliance. Each direct vent appliance must use its own separate vent system. Common vents are prohibited.

 **IMPORTANT**

- The horizontal termination must not be recessed into the exterior wall or siding.
- Horizontal vent runs must be level or rise 1/4" per foot toward the vent termination.
- Clearances around the vent termination must be maintained.

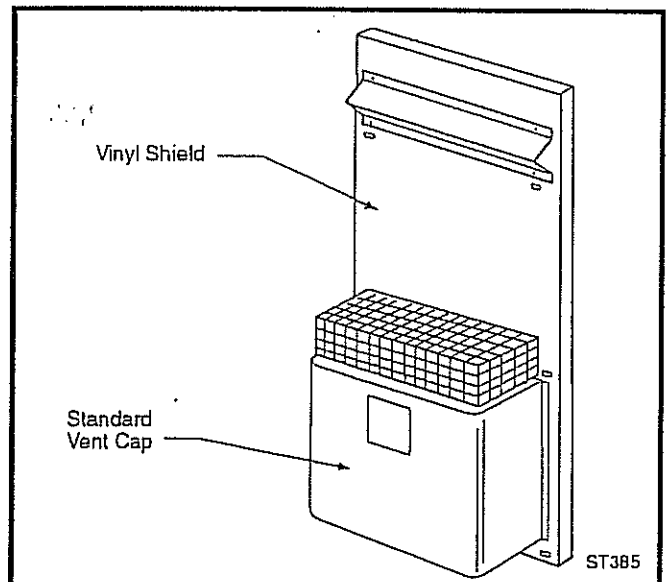

Fig. 17 Positioning the siding shield (Vermont Castings, Majestic Products #7DVSS shown).

Vent Termination Clearances

The location of the vent terminal must meet clearance specifications as shown in Figures 18-20. Also follow these guidelines when determining the vent terminal location:

1. Do not locate the terminal where people may come into accidental contact with it while the appliance is operating.
2. There must not be any obstruction such as bushes, fences, decks, garden sheds, or utility buildings within 24" (60cm) of the terminal cap.

3. Do not locate the terminal where it might be damaged by such things as car doors, lawn mowers, or snowblowers. The terminal should be located away from areas where it could become blocked by snow or ice build-up. Be sure to check the vent termination area after snow falls, and clear it to prevent accidental blockage of the vent system. When using a snowblower, be careful to direct snow away from the terminal area.

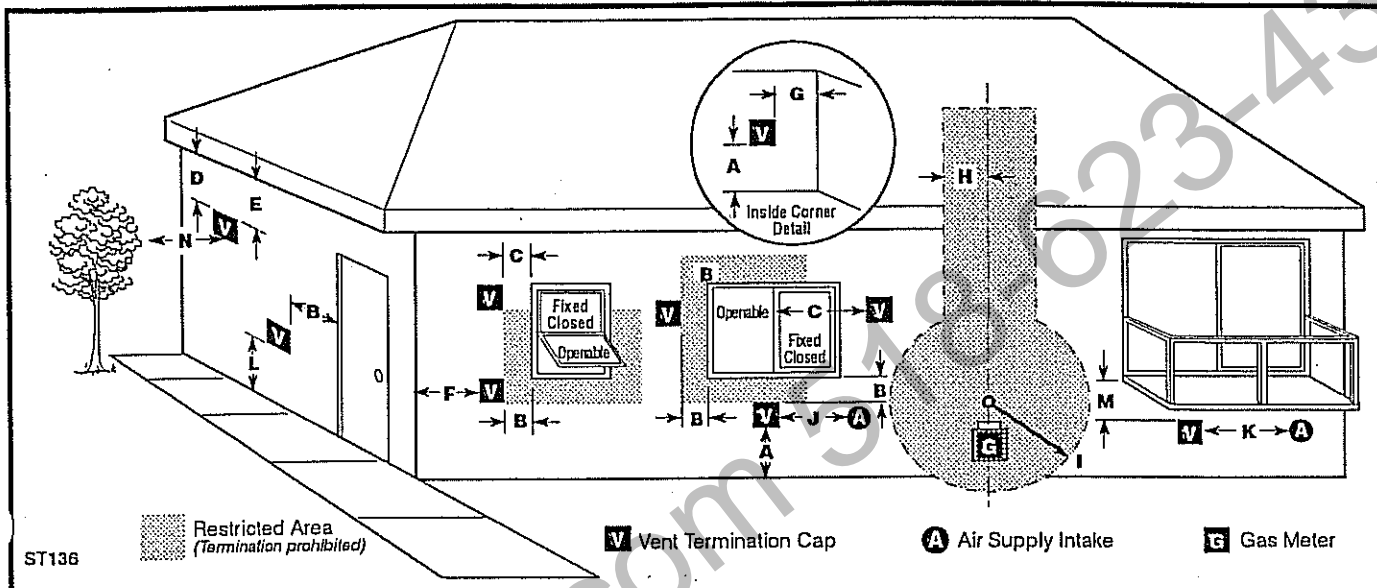

- A:** Clearance above grade, veranda, porch, deck, or balcony - * 12 in. (30cm) min.
- B:** Clearance to window or door that may be opened - * 12 in. (30cm) min. to top and sides * 24 in. (60cm) min. below
- C:** Clearance to permanently closed window - 12 in. (30cm) min. recommended to prevent condensation on window above.
- D:** Vertical clearance to ventilated soffit located above the terminal within a horizontal distance of 2 ft. (60 cm) from the centerline of the terminal - 18 in. (46cm) min.
- E:** Clearance to unventilated soffit - 12 in. (30cm) min.
- F:** Clearance to outside corner - 6 in. (15cm) combustible, 2 in. (50mm) noncombustible
- G:** Clearance to inside corner - 6 in. (15cm) combustible, 2 in. (50mm) noncombustible
- H:** May not be installed above a meter/regulator assembly within 3 ft. (90cm) horizontally from the vertical centerline of the regulator.

- I:** Clearance to service regulator outlet - * 6 ft. (1.8m) min.
- J:** Clearance to non-mechanical air supply inlet for the building or to the combustion air inlet to any other fireplace - * 12 in. (30cm) min.
- K:** Clearance to a mechanical air supply inlet - 6 in. (1.8m) min.
- L:** † Clearance above paved sidewalk or a paved driveway located on public property - * 7 ft. (2.1m) min. (For U.S. installations, follow the current National Fuel Gas Code, ANSI Z223.1)
- M:** Clearance under veranda, porch, deck, or balcony - >12 in. (30cm) min. (See Note A)
- N:** Clearance to trees, bushes, - 24 in. (60cm)
- O:** Clearance above a roof shall extend a minimum of 24 in. (610mm) above the highest point when it passes through the roof surface.
- P:** The vent shall have a minimum horizontal clearance of 24 in. (610mm) from any vertical obstruction.

† A vent shall not terminate directly above a sidewalk or paved driveway which is located between two single-family dwellings and serves both dwellings.*

Note A: Only permitted if veranda, porch, deck, or balcony is fully open on a minimum of 2 sides beneath the floor.*

Note B: As specified in CAN/CGA B149 (.1 or .2) Installation Codes (1991). Note: Local codes or Regulations may require different clearances.

* For U.S. installations, follow the current National Fuel Gas Code, ANSI Z223.1

Fig. 18 Vent termination clearances.

4. Vinyl siding requires protection from vented heat directly above the vent opening. Use Vinyl Siding Shield #7DVSS.

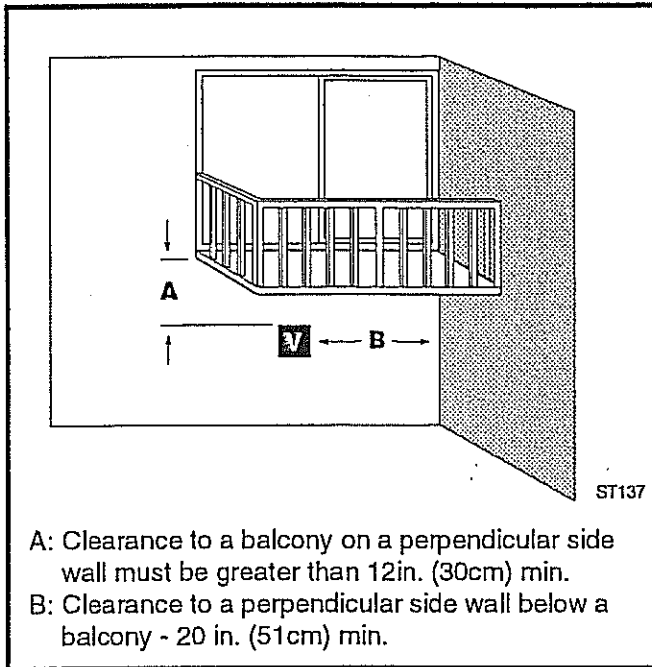

Fig. 2-15 Vent clearance under balcony with sidewall.

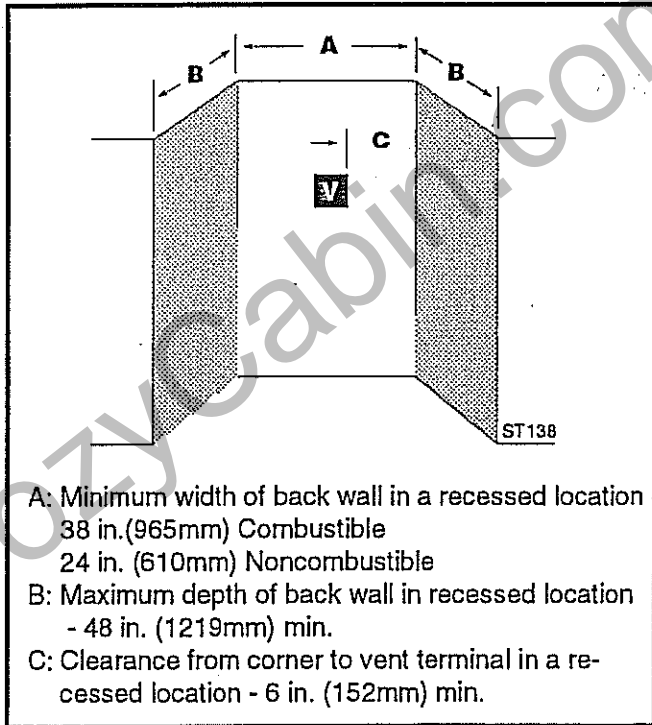

Fig. 20 Vent clearance within a recessed wall.

Through-the-Roof Installations

The PDV20 is approved for vertically-terminated installations from 12 feet to 35 feet in height.

- The vent must terminate in the shaded area in the chart below.
- Up to an 8-foot horizontal run can be installed in the vent system, with a maximum of three 90° elbows.
- Up to two 45° elbows can be used within the horizontal run. For each 45° elbow used in the horizontal run the maximum horizontal vent length must be reduced by 18 inches.
- The installation can include two sets of 45° elbows. From 0 to a maximum of 8 feet of vent pipe can be used between offsets.
- A #7DVCS must be used to support offsets.
- This installation will require you to determine the roof pitch and used the appropriate roof flashing #7DVSKV (A,B, or F). See the venting components list.
- A 1 3/4" restrictor plate, supplied with the heater, must be used in all vertically-terminated installations.

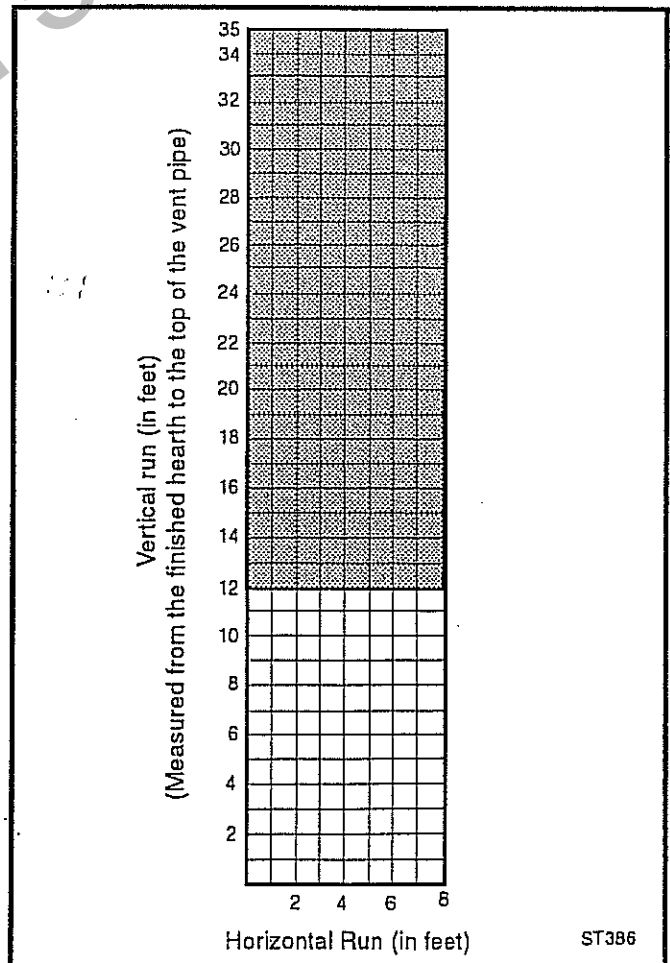

Fig. 21 Vertical vent termination window.

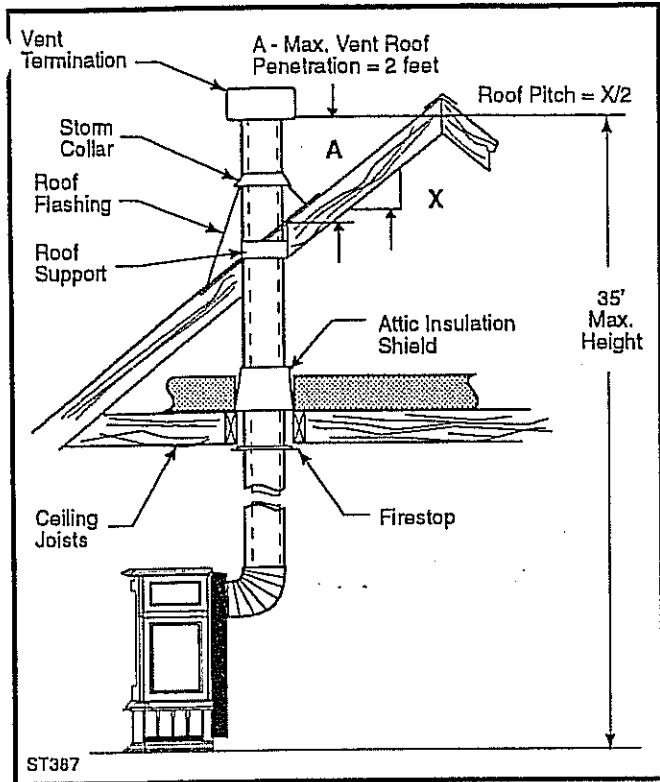

Fig. 22 Vent (chimney) height.

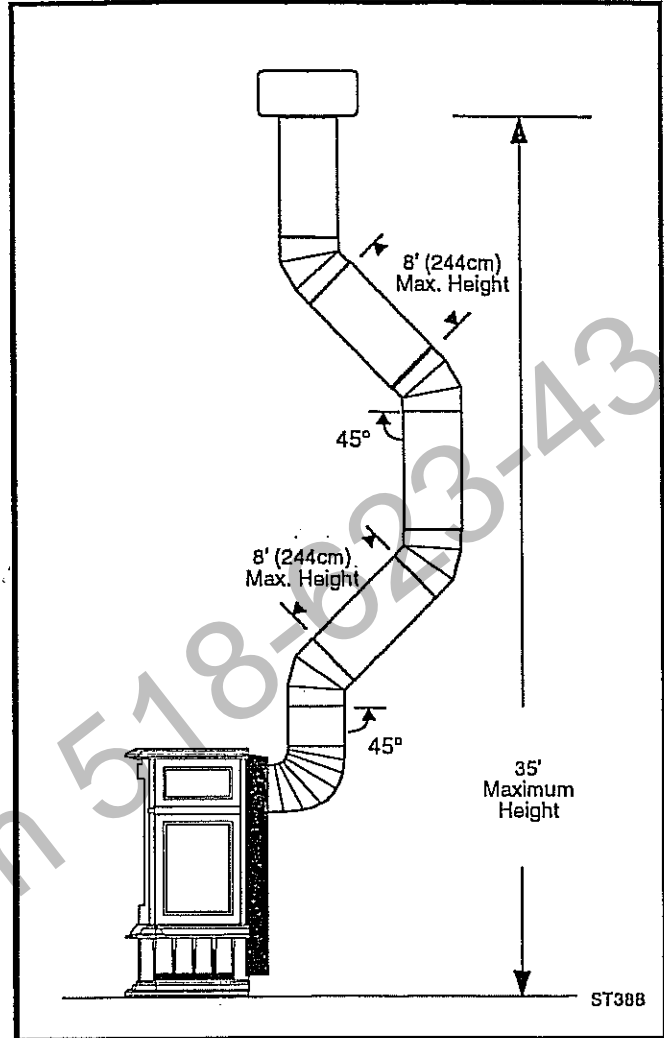

Fig. 23 Typical offset installation.

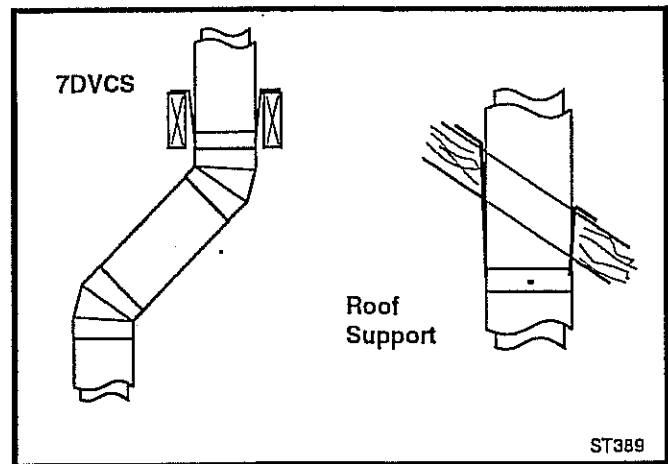

Fig. 24 Typical applications.

Assembly Procedures

Parts Bag Contents:

- 1/4-20 x 3/8" Phillips screws, 3 (Vent Starter)
- #12 x 1/2" hex-head sheet metal screws 3 (Vent adapter to collar)
- #10 x 1/2" Phillips sheet metal screws 3 (control panel to bottom heat shield)
- Stove cement, 1 tube
- 1 3/4" Vent Restrictor Plate
- Switch Wire Harness
- Owner Registration Card
- Hole plug (control panel)
- Lava Rock package
- Switch Heat Shield
- Vent Starter Pipe
- On/Off Switch
- Control Panel
- Wire tie
- On/Off Switch label
- Plastic bushing

Tools/Materials Required:

- Phillips screwdriver
- utility knife
- tin snips
- masonry anchors or TEK screws
- nonhardening mastic
- RTV Hi-Temp Silicone sealant
- tape measure
- drill & .140 drill bit
- caulk gun

Wear safety goggles and work gloves.

Complete all site preparations appropriate to your specific installation before you begin assembly of the heater. These include:

- Hearth area modifications and existing chimney cap removal for air intake and vent termination (for fireplace installations only).
- Framing required wall and/or roof openings for direct-vent installations.

Before you begin assembly of the PDV20, read this section of the manual completely to familiarize yourself with the procedures that apply to your installation. The installation will be most easy if you follow the steps in the order presented. Inspect all parts for damage and notify your dealer if any damage is found. **Do not install this heater if any damage is evident.**

WARNING

FAILURE TO POSITION THE PARTS IN ACCORDANCE WITH THESE DIAGRAMS OR FAILURE TO USE ONLY PARTS SPECIFICALLY APPROVED FOR USE WITH THIS HEATER MAY RESULT IN PROPERTY DAMAGE OR PERSONAL INJURY. THIS HEATER AND COMPONENTS ARE VERY HEAVY. HAVE ASSISTANCE AVAILABLE FOR ASSEMBLY.

Firebox Preparation

Unpack the Log Set and Rear Shroud

Cut the shipping straps and remove the Rear Shroud carton. (Fig. 25) Do not remove the firebox from the shipping pallet yet. The Log Set is packed inside the firebox. The Glass Panel must first be removed to install the Log Set within the firebox.

1. Pivot the two latches at the top corners to disengage the latches from the retainer posts at the top of the firebox. (Fig. 26) Lift the glass frame assembly off the front and place it out of the way on a flat, padded surface such as a counter protected by a towel. *The glass panel will not be replaced until the entire installation is complete and the pilot has been lit.*
2. Remove the Log Set from its packaging and set the pieces aside. Remove any packing material from the firebox.
3. Remove the Rear Shroud from the shipping carton.

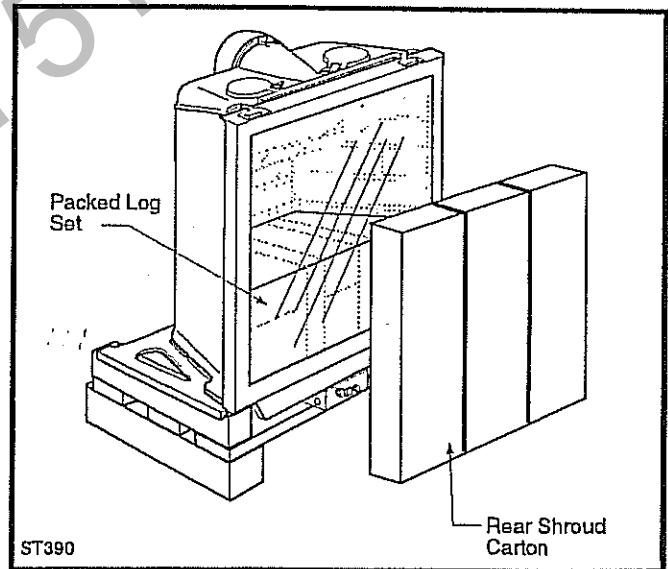

Fig. 25 PDV20 firebox as shipped.

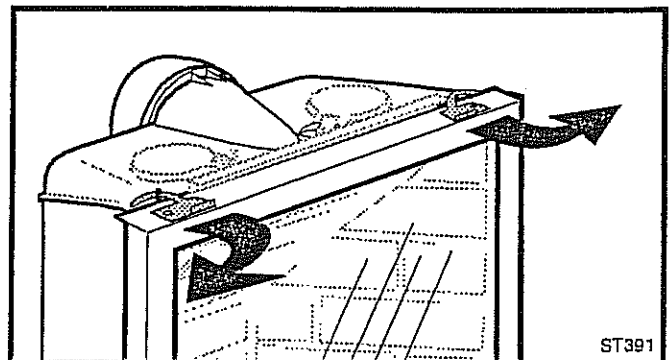

Fig. 26 Pivot the locking latches to release the glass frame.

Heater Shell Assembly

Unpack the cast iron stove shell parts from the shipping carton. Inspect each part for shipping damage and set them aside on a protective surface. *Porcelain enameled surfaces are fragile. Handle porcelain enameled castings tenderly.*

While the Pinnacle shell is depicted in the figures below, the procedures are the same for the Stardance shell (SDVR) components. See the Appendix for detailed dimensional and clearance information specific to the SDVR.

1. Use only the rear shroud supplied with this firebox. Attach the rear shroud to the left side plate by aligning the key holes with the two wingbolts (A) installed in the side. (Fig. 27) If necessary, turn the wingbolts to orient the blades vertically. Slide the shroud downward to engage it behind each washer (B) and then tighten the wingbolts.

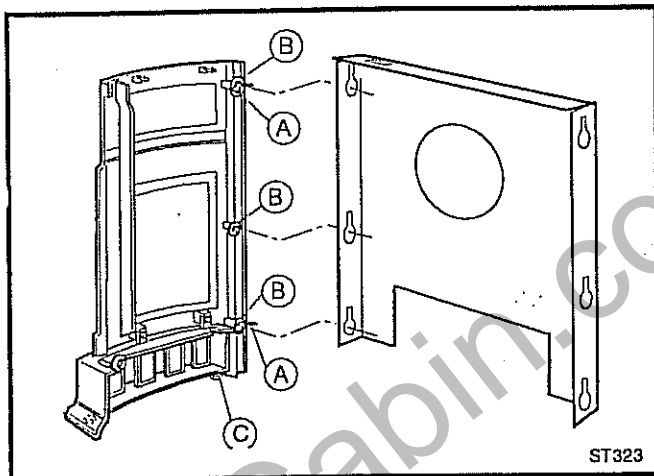

Fig. 27 Fasten the left side to the rear shroud.

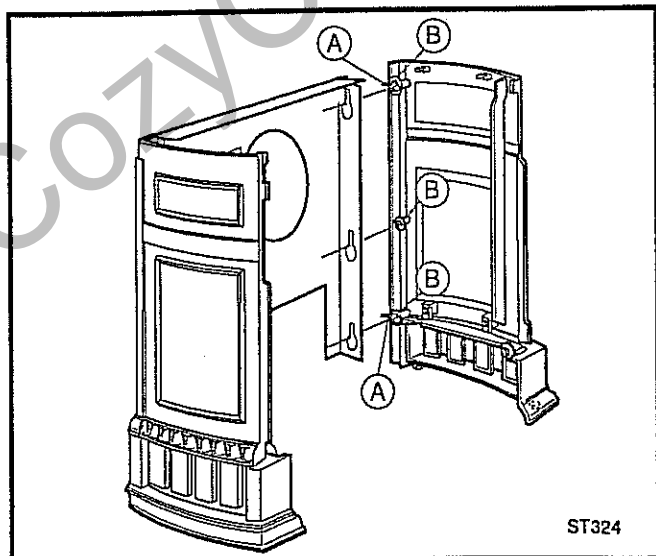

Fig. 28 Fasten the right side to the rear shroud.

2. Repeat Step 1 to attach the Right Side Plate to the Rear Shroud. (Fig. 28) Align the two side plates to be perpendicular to the Rear Shroud as in Figure 30.
3. Attach the Switch Heat Shield.
 - Locate the Switch Heat Shield and black plastic wire harness bushing in the hardware bag. Press the bushing into the wire harness hole in the bottom of the heat shield.
 - Loosen the upper right wingbolt enough to enable you to engage the slot in the heat shield behind the wingbolt. Retighten the wingbolt.
4. Move the entire assembly close to the stove's final position.

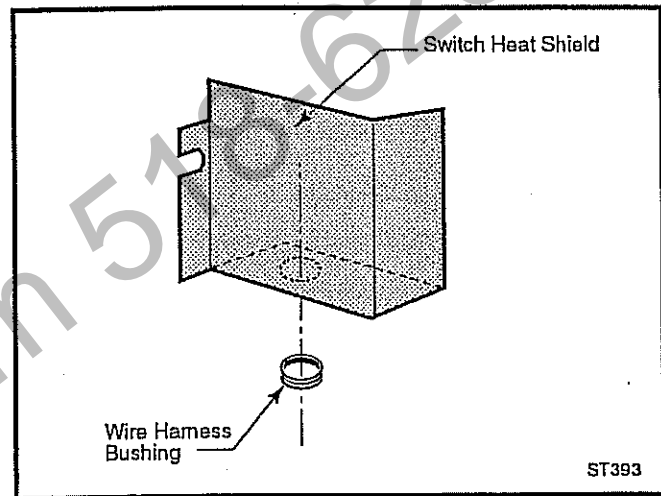

Fig. 29 Insert the wire harness bushing into the bottom of the switch heat shield.

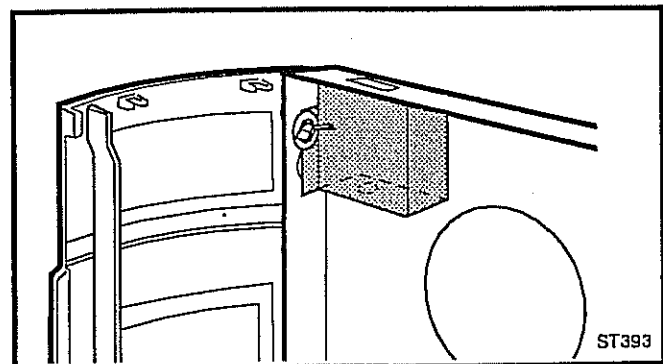

Fig. 30 Fasten the heat shield switch to the rear shroud.

Install the firebox

NOTE: Dry fit the Starter Pipe and first vent pipe sections to the flue collar to align and drill pilot holes as necessary, while the firebox is on the shipping pallet. You will not be able to drill holes after the firebox is installed.

Also, you will find it easiest to connect the flexible or hard gas supply pipe to the burner control valve before installing the firebox into the shell. (Fig. 55)

1. Remove any cardboard packing material from the top of the firebox. Double-check that the sides align at 90° to the rear shroud.
2. Lift the PDV20 firebox assembly and slide it back into position in the shell. The base of the firebox should rest on the side support shelves as in Figures 31-32. Type A has two steel tabs on each side, which engage the raised ridge on the top edges of the firebox base. Type B uses a large washer at the bottom forward corners of each side to engage notches in the undersides of the firebox base. Make sure that either the large washer or the steel tabs engage the firebox base as shown in Figure 32. Properly positioned, the firebox will be level and locked in place. If not, adjust the levelling screws (C, Fig. 27) in the base of each side to keep the entire unit level.

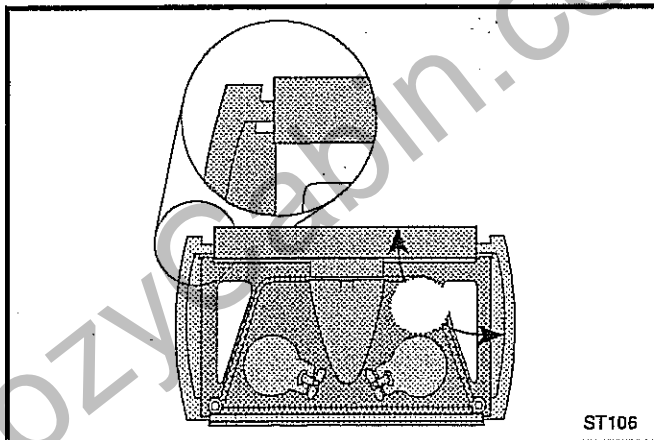

Fig. 31 Slide the firebox into position; check the alignment of both sides with the rear shroud.

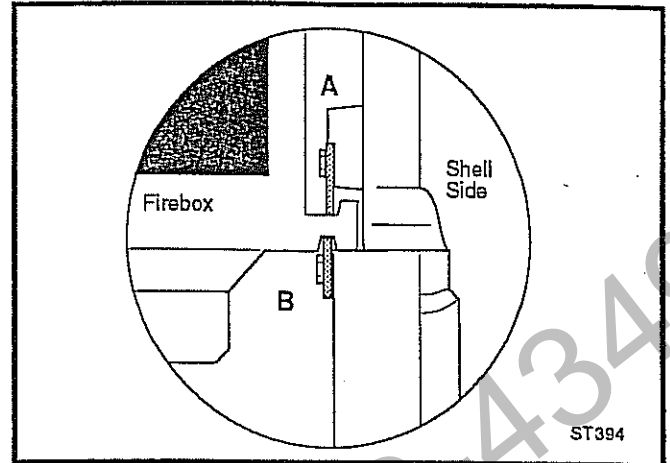

Fig. 32 The shell sides engage the firebox base either; A, with steel tabs capturing a ridge on the top of the firebox base edges, or B, with a washer engaging a notch in the underside of the firebox base.

If you are not installing a fan, proceed to the appropriate vent assembly section.

Install Optional Fan Kit #2960/FK28

Fan Kit Contents:

- #10 x 1/2" phillips screws, 6
- Control Knob
- Retainer Collar
- Snapstat
- Snapstat Bracket
- Blower Assembly w/ Rheostat Control

1. Attach the Snapstat to the Bracket using two #10 x 1/2" phillips sheet metal screws as shown in Figure 33.
2. Locate and remove the 1/4-20 x 3/8" hex head bolt installed in the hole in the right rear ledge of the firebox. (A, Fig. 33) Use that bolt to secure the Snapstat Bracket to the firebox. The mounting hole is slotted to allow you to adjust the bracket so that its head makes contact with the firebox surface. (Fig. 33)
3. Attach the Fan to the firebox by engaging the upper flange of the fan skirt under the lower edge of the Shroud and secure the skirt with the four screws provided with the kit. (Figs. 34, 35)
4. The Rheostat Control switch attaches to the Control Panel provided in the parts bag with the stove.
 - Align the switch box with the hole in the right side of the Panel, aligning the locator pin with the smaller hole in the panel. (Fig. 36)
 - Attach the Retaining nut to the switch control shaft to fasten it to the panel.
 - Attach the control knob to the rheostat shaft.

- Do not install the Control Panel until after the gas line and control switch wiring connections have been made.
 - Use the wire tie to fasten the fan and rheostat wire harness together to the tubing under the bottom heat shield.
5. A length of silicone tape is included for installation between the Top Plate and the Rear Shroud, should you find that contact between these two surfaces causes vibration while the fan is operating.
- Remove the Top Plate.
 - Cut the self-adhesive tape to size as needed, remove the backing paper and place tape on the top edge of the Shroud at those locations where it will eliminate direct contact between the Shroud and the Top Plate. (Fig.37)
 - Replace the Top Plate.

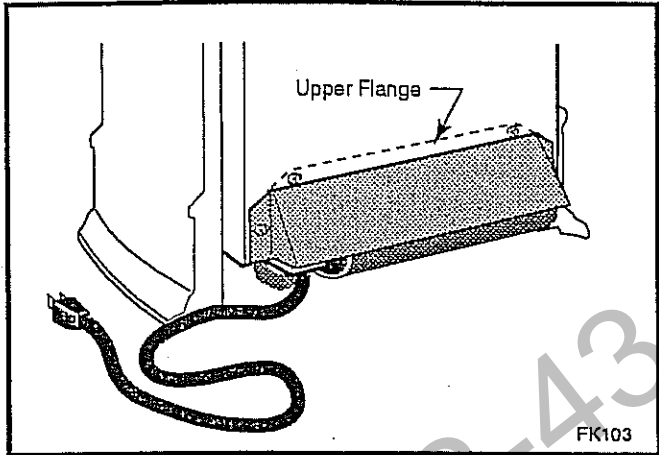

Fig. 35 The fan properly positioned.

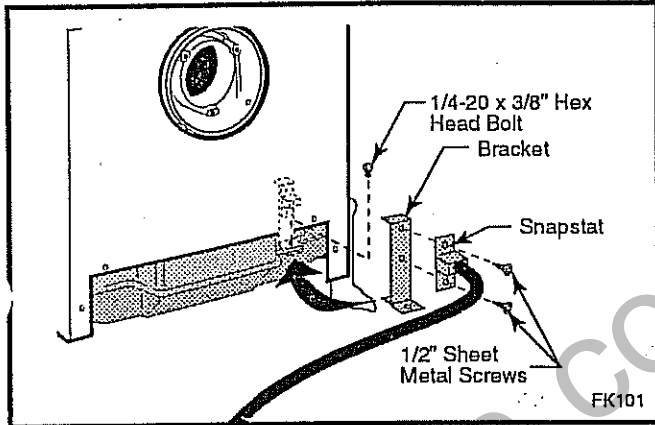

Fig. 33 Snapstat assembly and installation.

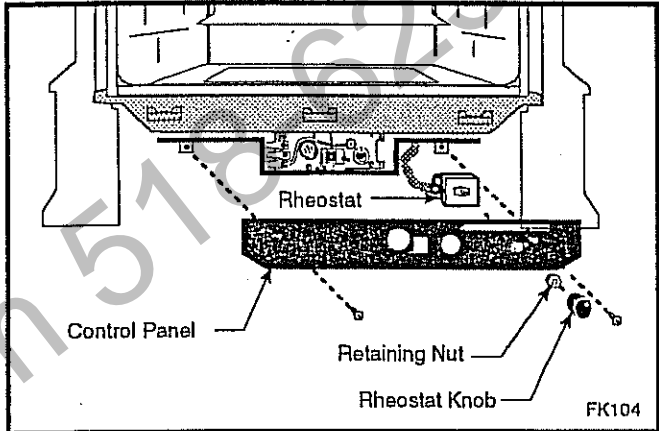

Fig. 36 Attach the rheostat to the control panel.

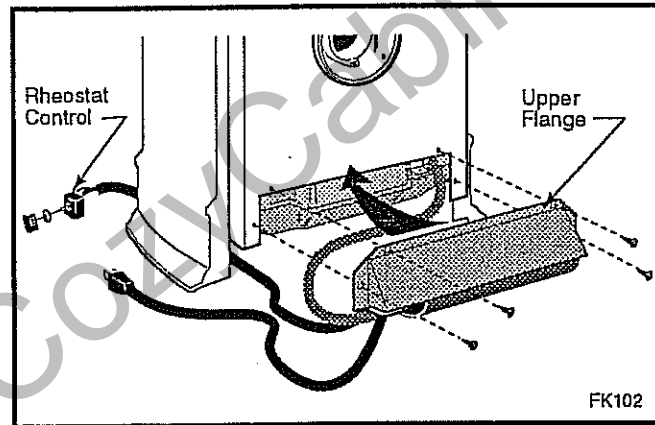

Fig. 34 the upper flange of the fan skirt should be located behind the lower edge of the shroud.

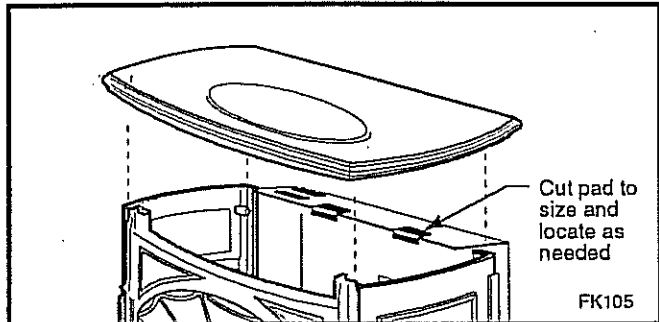
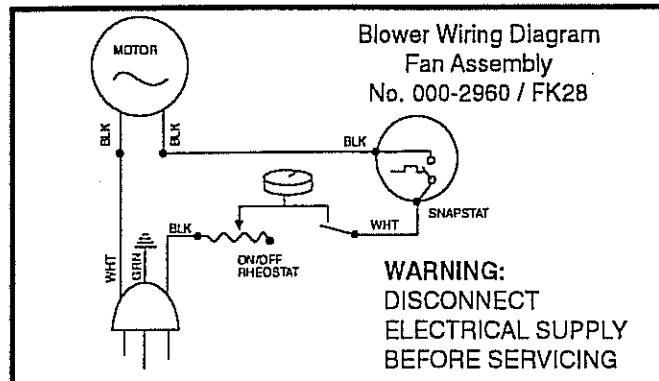

Fig. 37 Vibration dampening pad location.

WARNING

THIS APPLIANCE IS EQUIPPED WITH A THREE-PRONG (GROUNDED) PLUG FOR YOUR PROTECTION AGAINST SHOCK HAZARD AND SHOULD BE PLUGGED INTO A PROPERLY GROUNDED THREE-PRONG RECEPTACLE. DO NOT CUT OR REMOVE THE GROUNDING PRONG FROM THIS PLUG.



Fireplace Vent System

Note: The collar extending down from the Termination base is the air intake collar. Use the flex vent liner, marked with a **blue line**, to connect between this collar and the *lower* flue collar on the Transition Connector. Also make sure the other flex vent liner is attached to the upper Transition Connector collar and the Rain Cap. (Fig. 58)

1. Clean the top of the chimney as needed, to ensure a good seal between it and the vent termination.
2. Slide the insulation sleeves provided in the termination kit over the two 3" flex liners (to be attached to the 3" flue collar and cap of the termination assembly).
3. Feed 3" flex vent from the bottom of the termination assembly up through the 4" sleeve. Apply high-temperature sealant to the rain cap collar, and slide the flex vent over the end of the rain cap collar, fastening with the clamp provided.
4. Slide the flex liner back through the 4" sleeve until the rain cap/collar engages over the sleeve. Attach the cap to the sleeve with three sheet metal screws provided in the kit.
5. Apply high-temperature sealant over the air intake collar, and attach the intake flex vent (blue) with a clamp.

6. Apply high-temperature sealant to the top of the chimney. Feed the two liners down through the chimney flue and damper opening. Fasten the termination assembly to the chimney with the four set screws (C) provided.
7. Trim the flex liners as needed. Each should be only long enough to connect to the Transition Connector. There should be no sag in either flex liner when the stove is in place.
8. Attach the flex liners to the Transition Connector, using high-temperature sealant and clamps as shown in Figure 38. Prop the connector in rough position until the heater is in place in front of it.

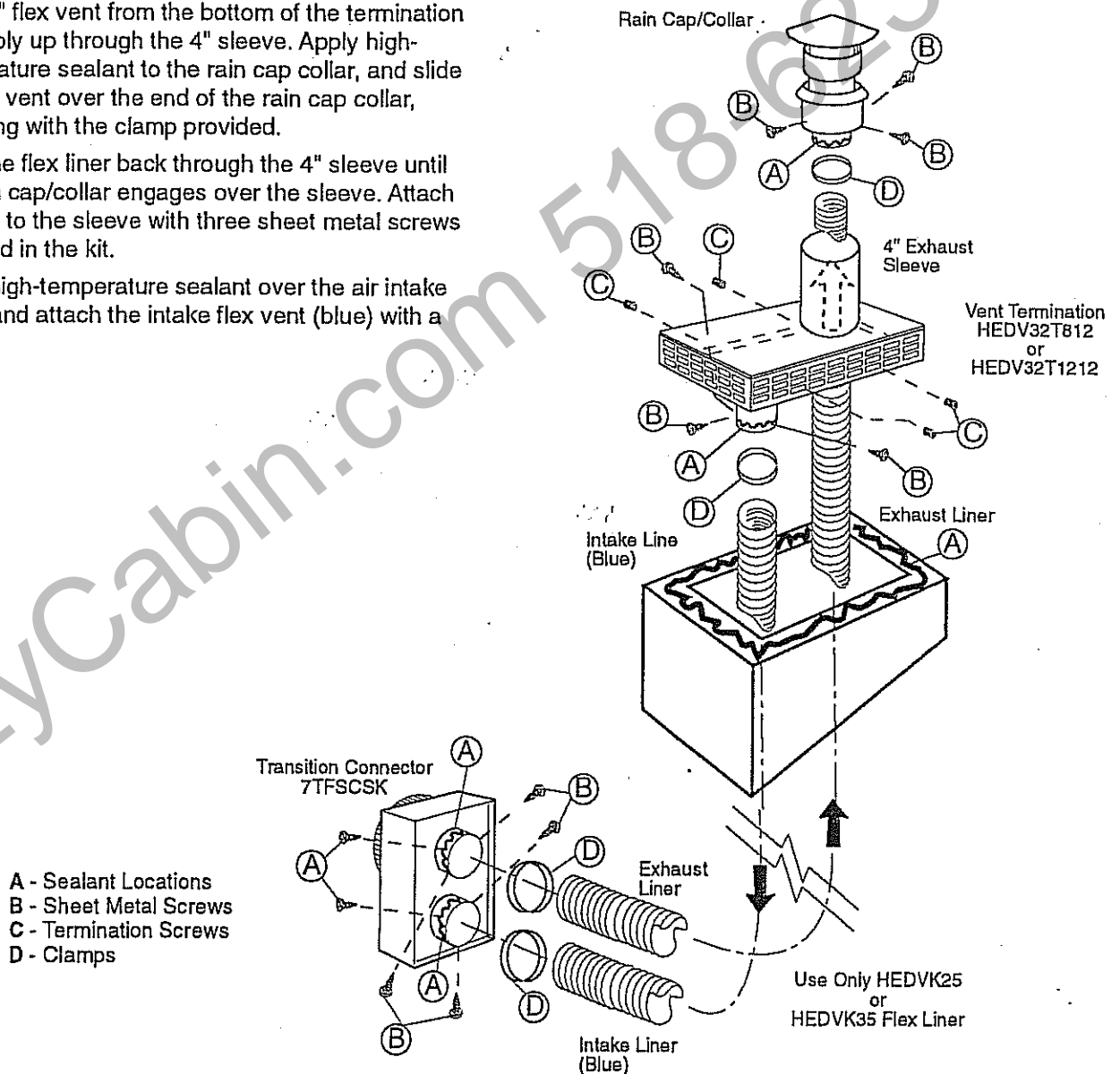

Fig. 38 Fireplace vent system installation.

Connect the PDV20 to the Vent System

1. Apply high-temperature sealant to the outside of the male end of the vent starter pipe provided with the firebox. Install the starter pipe in the exhaust outlet on the back of the firebox. Fasten it in place with three Phillips-head screws. (Fig. 39)
2. Apply sealant to the outside of the 4" collar and the inside of the 7" collar, on the Transition Connector.
3. Remove any temporary props from below the Transition Connector in the fireplace. Move the heater firebox/shell assembly into position in front of the fireplace. Have a helper support the Transition Connector, and guide its intake and exhaust pipes into the starter pipe and the flue collar on the back of the firebox. Align the three screw holes on the Transition Connector collar with the holes in the flue collar. You may need to drill a 3/8" hole through the top of the shroud panel to access the upper screw. Use a stub handle phillips screwdriver to secure the joint with sheet-metal screws. (Fig. 40)
4. Put the heater in its final position, and ensure that there is no sag in either of the flex pipes.

This completes the vent installation procedures for fireplace installations of the PDV20 Heater. Proceed to the section titled "Install the Wiring Harness".

Vertical Through the Roof Vent Assembly

Note that all vertically terminated installations must use the 1 3/4" Restrictor Plate included in the hardware bag. The plate must be installed within the firebox Inner Flue Collar to insure that a proper air/fuel ratio is maintained in an appliance vented through the roof. (Fig. 41)

Make certain that the vent system conforms to all other requirements for vertical termination as specified on page 14.

This installation will require that you first determine the roof pitch and use the appropriate vent components. See the component listing on page 9.

1. **Locate the final position of the stove,** observing all clearances for both the vent and the stove.
2. **Determine the location of the roof termination** and plan the vent run between the roof and the flue collar of the stove. Follow the guidelines in the previous chapter of this manual.
3. **Attach the Inner Elbow Pipe to the Starter Pipe.**
Apply sealant to the crimped end of the inner elbow and attach it to the Starter Pipe with three sheet metal screws. (Fig. 41)

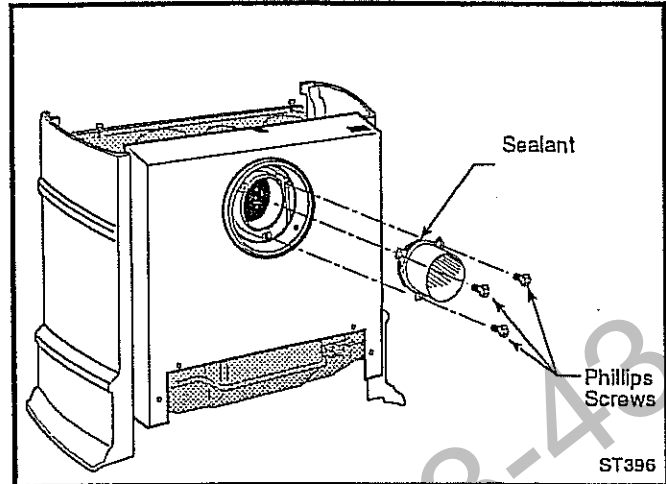

Fig. 39 Apply sealant to the starter pipe, and fasten it with three Phillips screws.

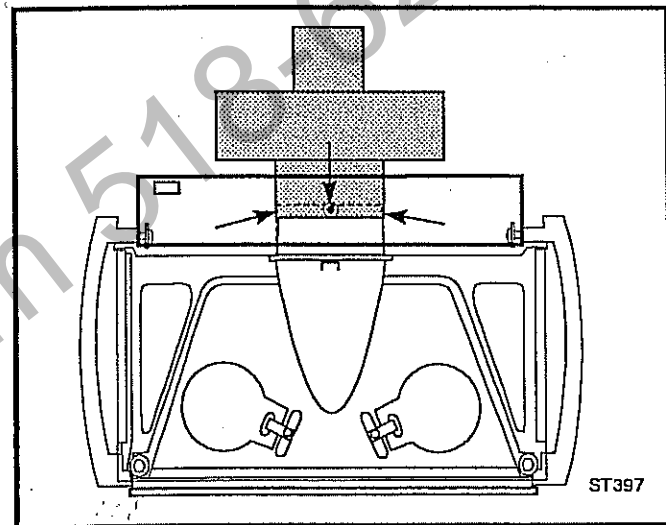

Fig. 40 Use stub handle phillips screwdriver to fasten the transition connector to the flue collar with three sheet metal screws.

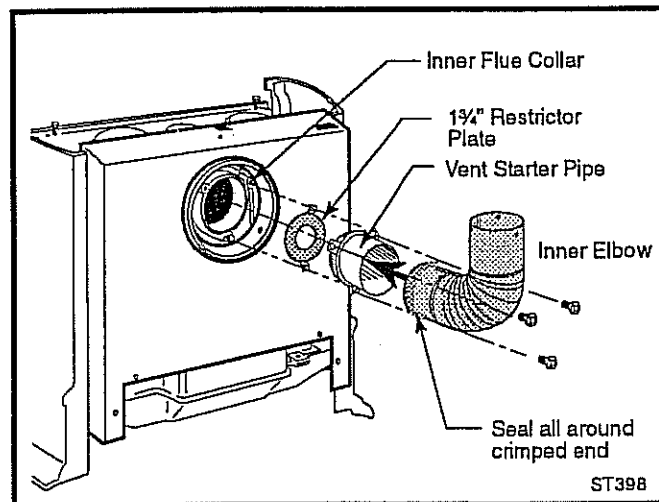

Fig. 41 Install restrictor plate and starter pipe/inner elbow assembly.

4. Install the Restrictor Plate and Starter/Inner Elbow Pipe assembly into the inner flue collar as using the three 1/4-20 x 1/2" phillips screws as shown in Figure 41.
5. Install the Outer Elbow Pipe.
Apply a 1/4" bead of sealant around the *inside* wall of the female end of the outer elbow. Orient the elbow crimped end up and insert it over the inner elbow. Secure the pipe to the flue collar at the pre-drilled holes with the three sheet metal screws supplied. Access the uppermost screw through the cutout, or drill an access hole through the top of the shroud, if necessary. The two side screws can be reached from above with the small screwdriver.
6. Plumb the centerline of the ceiling opening to the center of the elbow. Cut ceiling /floor openings equal to 9 3/8" x 9 3/8" (240mm x 240mm).
7. Plumb any additional openings through the roof or other construction that may be necessary. In all cases, the opening must provide a minimum of 1" clearance to the vent pipe.
8. Install Firestop(s) #7DVFS and Attic Insulation Shield #7DVAIS as appropriate. (Fig. 42) If there is a room above ceiling level, a firestop must be installed on both the bottom and top sides of the ceiling joists. If an attic is above ceiling level, an Attic Insulation Shield must be installed.
9. Install the appropriate roof support and flashing, making certain that the upper flange of flashing is below the shingles. (Fig. 43)
10. Working from the first pipe sections off the stove, Install appropriate pipe sections until the vent run reaches above the roof flashing. The enlarged ends of the vent sections always face downward. Apply sealant to each joint and secure with three sheet metal screws.
11. Install the Storm Collar and seal around the joints. (Fig. 43)
12. Add additional vent lengths to achieve the proper overall height.
13. Install the Terminal Cap. Apply cement to the inner and outer termination collars and install the terminal cap with four sheet metal screws.

This completes the vent installation procedures for installations terminating through the roof. Proceed to the section titled 'Install the Wiring Harness'.

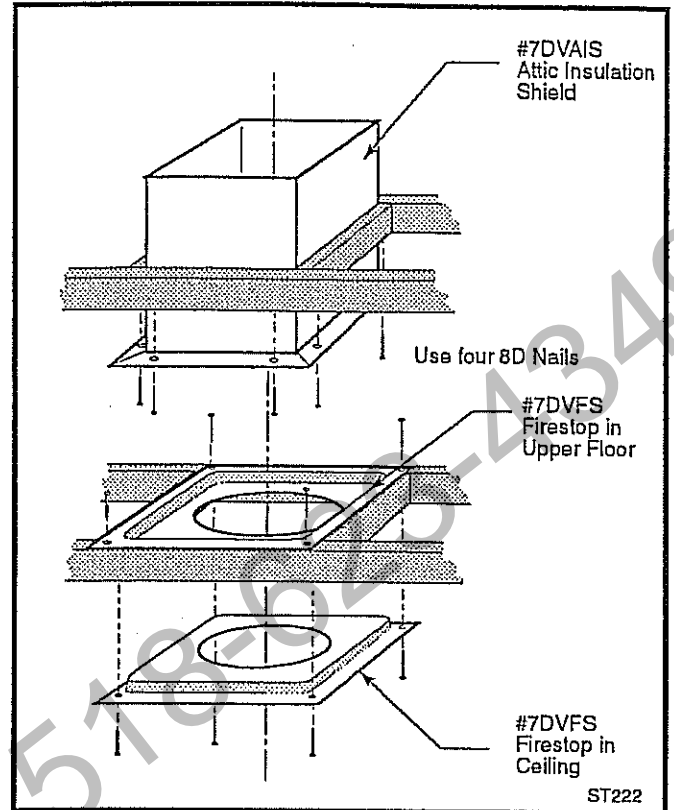

Fig. 42 Install firestops and attic insulation shield.

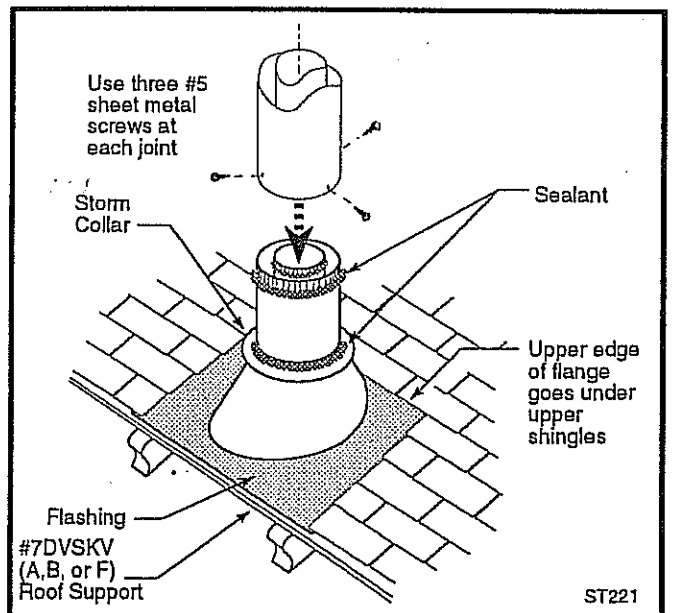

Fig. 43 Roof support and flashing.

Vertical Side Wall Termination

Use Minimum Side Wall Vent Kit 7TFMSK together with Transition Elbow, 7TDVRT90 for basic installation. See page 6 for additional vent components as may be needed.

1. Locate the vent opening on the wall. Be sure that the vent termination meets all clearance requirements noted on pages 11-13. It may be easiest to first position the stove and test fit the vent components to determine the wall opening centerline. Depending on whether or not the wall is composed of combustible materials, cut the opening to the size shown in Figure 44. Combustible wall openings must be framed in as shown in Figure 44.
2. Measure the wall thickness and cut the Wall Sleeve sections to proper length, (MAXIMUM 12"). Assemble the sleeve with the #8 sheet metal screws supplied. Attach the Firestop plate to the sleeve end with the holes. (Fig. 45) **NOTE: The Wall Sleeve is required in combustible walls only.**
3. Install the Wall Firestop/Sleeve assembly into the wall cutout and fasten the firestop to the wall cutout framing members. Seal the joint inside the firestop if necessary to keep cold air from being drawn into the living space.
 1. If necessary, measure to determine the length of pipe required from the Starter pipe to the exterior wall surface, including a 2" overlap at the joint. (Fig. 46) Use a hacksaw to trim the pipe as necessary. The maximum length of this section is 20" (508 mm).
5. Seal and install first the inner and then the outer straight pipe section to the flue collar of the stove. Secure each joint with 1/4-20 sheet metal screws.
6. Slip the Ventilated Wall Plate and the Trim Collar over the end of the horizontal pipe and position the stove to insert the pipe sections into the wall sleeve.
7. Orient the Ventilated Wall Plate with the open ends facing up and down. Secure the plate to the pipe using three sheet metal screws. Slide the Trim Collar up against the Wall Plate to cover the screws. (Fig. 46)
8. Install the vent terminal. (Fig. 46) Apply high temperature sealant one inch from the ends of the inner and outer collars. Guide the inner and outer vent termination collars into the adjacent pipes. Double check that the vent pipes overlap the collars by 2". Secure the termination to the wall with the screws provided and caulk the perimeter joint with weatherproof sealant.

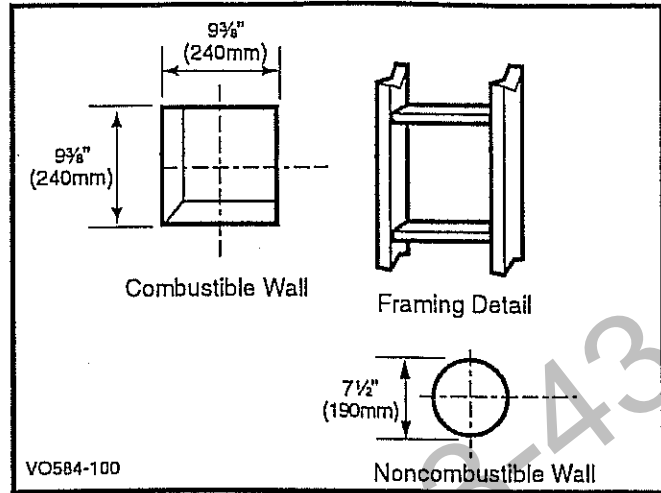

Fig. 44 Locate vent opening.

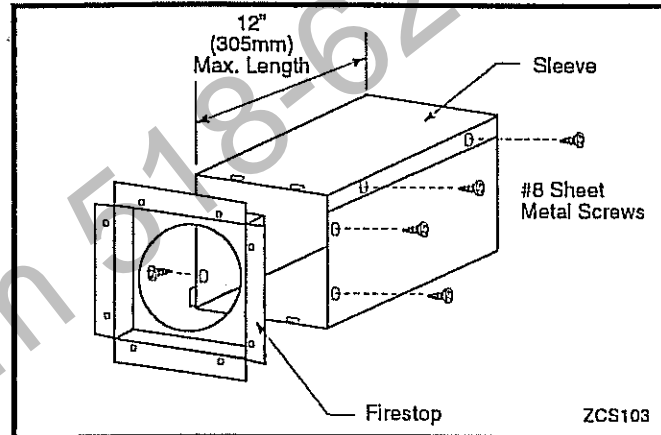

Fig. 45 Assemble the wall sleeve and firestop.

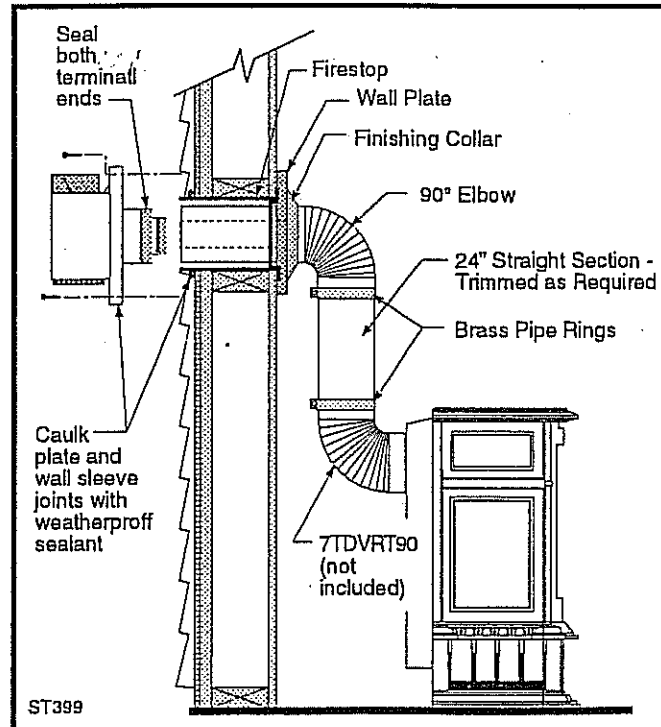

Fig 46 Minimum side wall vent kit, 7TFMSK with transition elbow, 7TDVRT90.

Rear Through-the-Wall Termination

1. Locate the vent opening on the wall. Be sure that the vent termination meets all clearance requirements noted on pages 11-13. Depending on whether or not the wall is composed of combustible materials, cut the opening to the size shown in Figures 47-48. See page 4 for horizontal vent centerline.

NOTE: The opening height for a Rear Vent Termination through a combustible wall will be 25 $\frac{3}{4}$ " (654 mm) from the floor. (Fig. 48)

A 7 $\frac{1}{2}$ " dia. round opening through a noncombustible wall will have a centerline 20" (508 mm) from the floor.

Combustible wall openings must be framed in as shown in Figure 44.

2. Measure the wall thickness and cut the Wall Sleeve halves to proper length, (MAXIMUM 12"). Assemble the sleeve with the #8 sheet metal screws supplied. Attach the Firestop plate to the sleeve end with the holes. (Fig. 48) **NOTE: The Wall Sleeve is required in combustible walls only.**
3. Install the Wall Firestop/Sleeve assembly into the wall cutout and fasten the firestop to the wall cutout framing members. Seal the joint inside the firestop if necessary to keep cold air from being drawn into the living space.
4. If necessary, measure to determine the length of pipe required from the Starter pipe to the exterior wall surface, including a 2" overlap at the joint. (Fig. 48) Use a hacksaw to trim the pipe as necessary. The maximum length of this section is 20" (508 mm).
5. Seal and install first the inner and then the outer straight pipe section to the flue collar of the stove. Secure each joint with 1/4-20 sheet metal screws.
6. Slip the Ventilated Wall Plate and the Trim Collar over the end of the horizontal pipe and position the stove to insert the pipe sections into the wall sleeve.
7. Orient the Wall Plate with the open ends facing up and down. Secure the plate to the pipe using three sheet metal screws. Slide the Trim Collar up against the Wall Plate to cover the screws.
8. Install the vent terminal. Apply high temperature sealant one inch from the ends of the inner and outer collars. Guide the inner and outer vent termination collars into the adjacent pipes. Double check that the vent pipes overlap the collars by 2". Secure the termination to the wall with the screws provided and caulk the perimeter joint with weatherproof sealant.

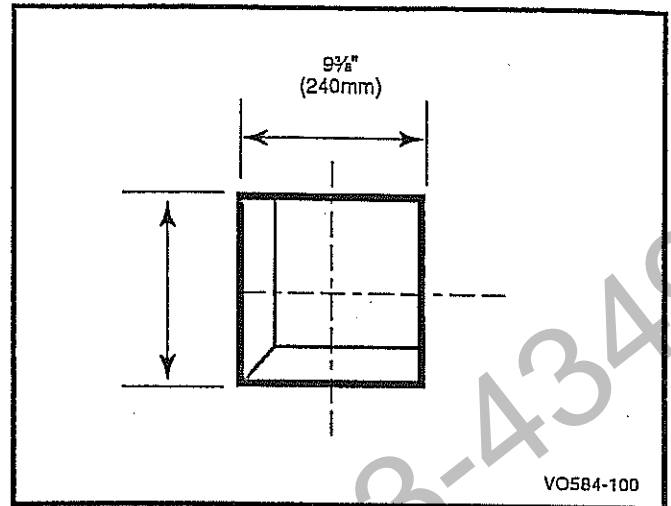

Fig. 47 Combustible wall opening - rear through-the-wall termination.

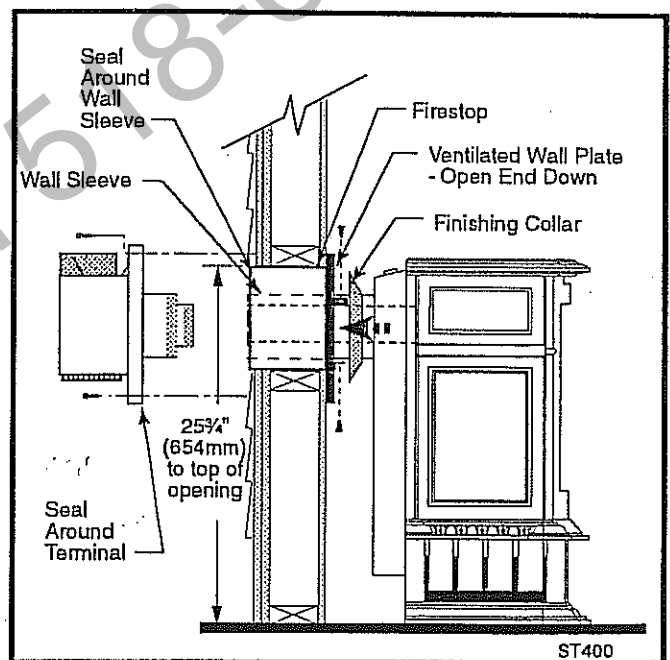

Fig. 48 Rear Vent Kit 7TFMSK installation.

Vent Termination Below Grade

Snorkel Vent Kit #7DVSKS should be installed when it is not possible to meet the required vent termination clearances of 12 inches (305mm) above grade level. The snorkel kit will allow installation depth of down to 7 inches (178mm) below grade level. The 7 inches is measured from the center of the horizontal vent pipe as it penetrates through the wall. If the venting system is installed below ground, a window well must be installed with adequate and proper drainage. (Fig. 49)

NOTE: Ensure that side wall clearances and vent run restrictions are maintained. See previous chapter.

A minimum 24" (608mm) vertical pipe must be installed when using the 7DVSKS Snorkel Kit. (Fig. 49)

With 24" vertical rise, the maximum horizontal run is 36" (915mm) from the back of the fireplace to the face of the exterior wall. See Vent Graph, Fig. 9 for the extended horizontal run if vertical run exceeds 24".

Installation

1. Establish the vent hole through the wall.
2. Remove soil to a depth of approximately 16" below the base of the snorkel. Install a window well (not supplied). Refill the hole with 12" coarse gravel and maintain a clearance of at least 4" below the snorkel. (Fig. 49)
3. Install the vent system as described on pages 22-23 as appropriate.
4. Ensure a watertight seal is made around the vent pipe joint at the inside and outside wall joints.
5. Apply high temperature sealant around the 4" and 7" snorkel collars.
6. Join the pipes and secure the snorkel termination to the wall using the screws provided.
7. Level the soil so that 4" clearance is maintained beneath the snorkel.

If the foundation is recessed, use extension brackets (not supplied) to secure the lower portion of the snorkel. Fasten the brackets to the wall first and then secure to the snorkel with self-tapping #8 x 1/2" sheet metal screws. It will be necessary to extend the vent pipes out as far as the protruding wall face. (Fig. 50)

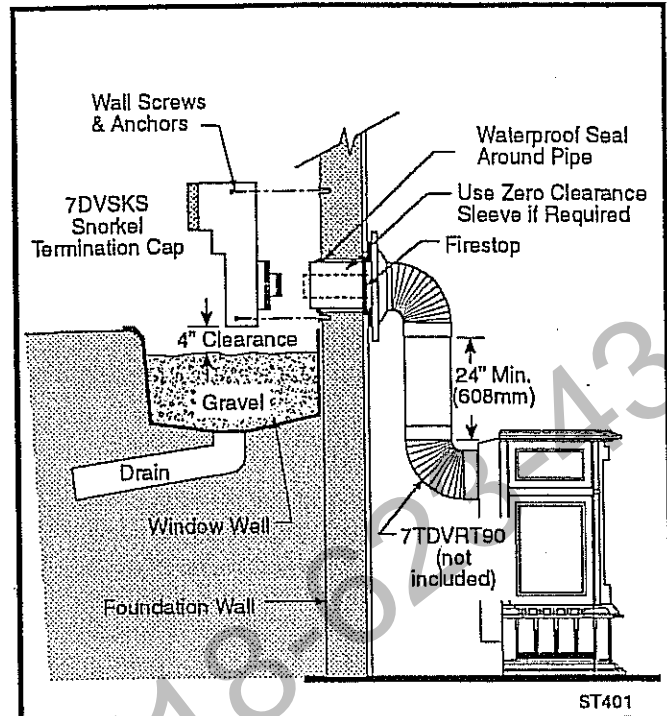

Fig. 49 Snorkel Kit 7DVSKS installation.

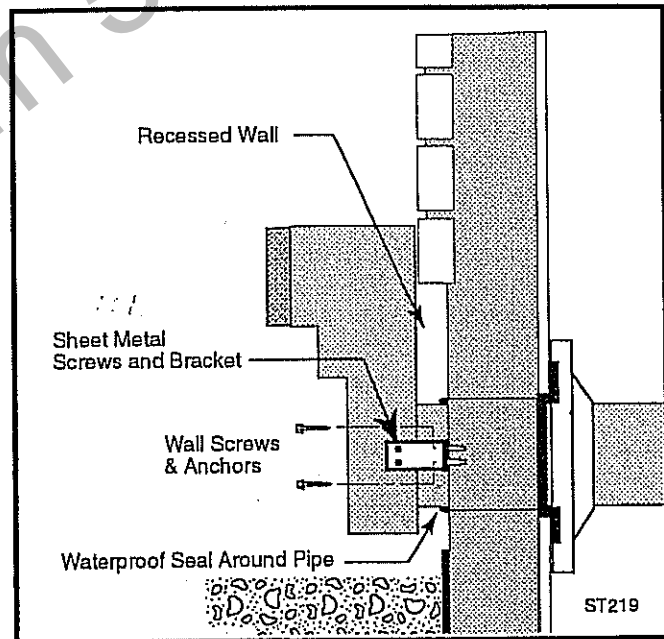

Fig. 50 Use extension brackets to mount snorkel against recessed wall.

Install the Wiring Harness and Switch

Remove the protective film from the T'stat/Off/On label, and press the label against the top panel of the rear shroud as shown in Figure 51.

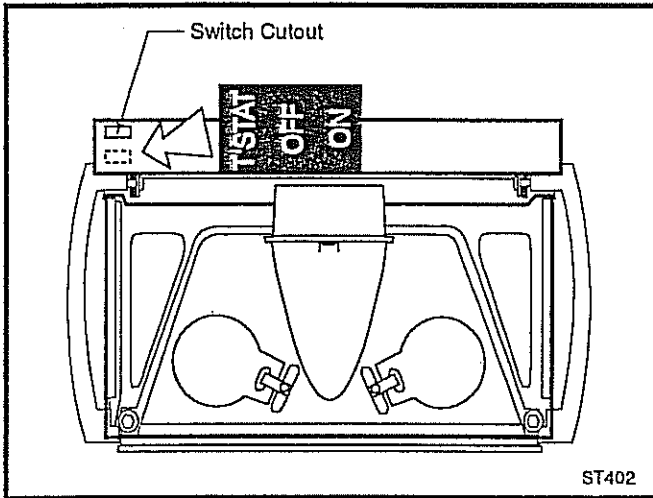

Fig. 51 Attach the switch label to the top of the rear shroud.

Pass the end of the wiring harness which has three connectors through the cutout in the left rear corner of the top of the rear shroud. Let the rest of the harness hang between the heater shell and the firebox.

Connect the three connectors from the wiring harness to the three terminal posts on the switch. The black connector attaches to the left post, the red connector attaches to the center post, and the white connector attaches to the right post. (Fig. 52)

Press the switch through the cutout in the top of the rear shroud, pressing it down completely.

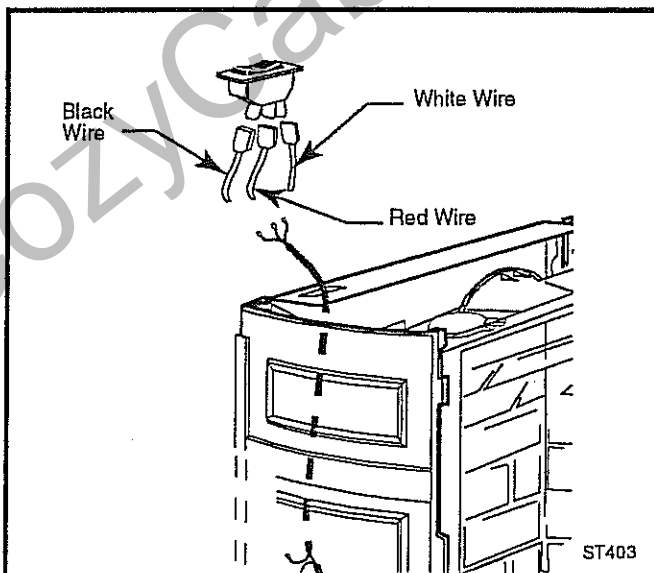

Fig. 52 Connect the wires to the switch.

Connect the Wiring Harness to the Control Valve

Attach the female flag connector with the black and white wires to the top terminal (the 'TP/TH' terminal) on the gas control valve. Attach the connector with the red wire to the bottom terminal (the 'TH' terminal). (Fig. 53)

Any loose wire may be coiled up and positioned between the valve wiring and tubing coil, or use a wire tie to keep it up out of the way.

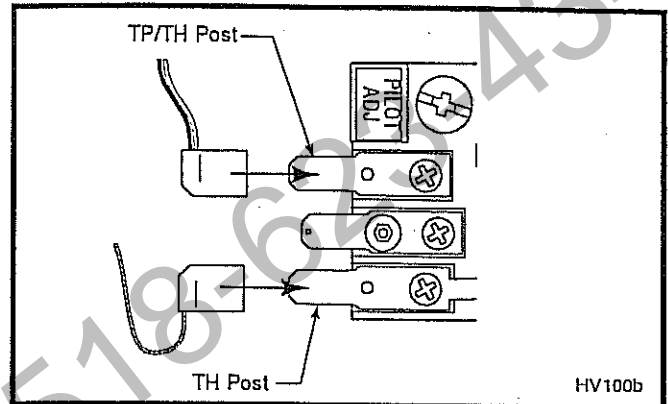

Fig. 53 Attach the switch wires to the valve.

Thermostat Connection

Use only a thermostat rated for 500-700 millivolts with this appliance.

Install an optional wall thermostat in the desired spot and run the wires to the stove location. Terminate the leads with 1/4" spade connectors. Join the spade connectors to the 1/4" female connectors on the wiring harness, accessible from under the left rear corner of the heater. (Fig. 54) Either wire may be connected to either terminal.

Note in the table below the appropriate gauge wire to use for the length of lead needed. Refer to the thermostat manufacturer's instructions.

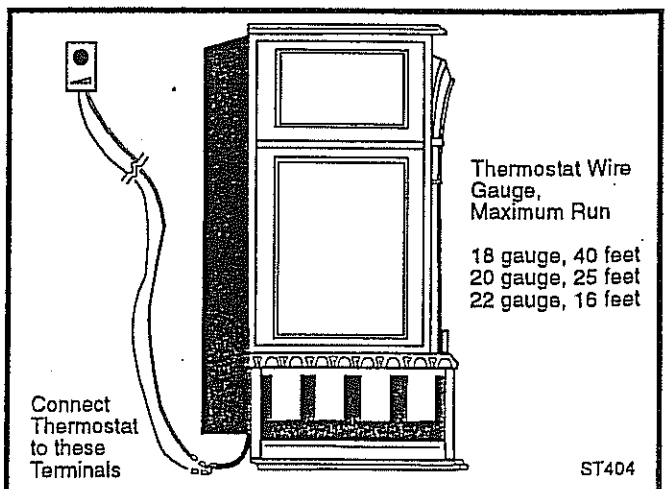

Fig. 54 Thermostat connection.

Connect the Gas Supply

Check the rating plate on the cable under the valve to confirm that the burner is configured for the type of fuel to be used. The heater is not convertible between fuels without use of a certified fuel conversion kit. Exactly follow the instructions provided with the kit.

CAUTION

THIS APPLIANCE MUST BE CONNECTED TO THE GAS SUPPLY LINE ONLY BY A QUALIFIED GAS SERVICE TECHNICIAN. FOLLOW ALL LOCAL CODES.

The PDV20 Heater and its individual shutoff valve must be disconnected from the gas supply piping during any pressure testing of that system at test pressures in excess of 1/2 psig. (3.5 kPa).

The PDV20 Heater must be isolated from the gas supply piping system by closing its individual manual shutoff valve during any pressure testing of the gas supply piping system at test pressures equal to or less than 1/2 psig.

1. Connect the main gas supply to the control valve inlet using a 3/8" NPT male fitting. (Fig. 55)
2. Pressure test the system using the tap accessible on the front of the control valve. (Fig. 55)
3. Use soapy water to test for leaks at all joints before operating.

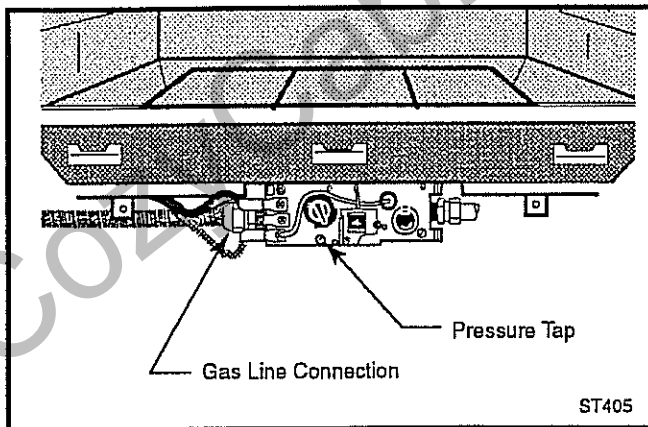

Fig. 55 Connect the gas line to the left side of the valve.

CAUTION

THERE MUST BE A GAS SHUTOFF BETWEEN THE STOVE AND THE SUPPLY.

With Natural Gas, use a 3/8" or 1/2" natural gas supply line with an input of 20,000 BTUs at a manifold pressure of 3.5" and minimum inlet supply for adjustment of 5.0" W.C.

With Propane, use a 3/8" or 1/2" propane gas supply line with an input of 20,000 BTUs at a manifold pressure of 11.0" and minimum inlet supply for adjustment of 11.0" W.C.

Install the Valve Cover Plate

Use the two remaining sheet metal screws from the parts bag to attach the Cover Plate over the control valve at the front of the stove. (Fig. 56)

The bottom ends of the Rating Plate and Operating Instruction Plate should protrude through the slot on the right upper side of the valve cover plate. These plates are permanently attached to the stove bottom by a wire cable.

Capture the wiring harness (and the fan rheostat cord, if a fan is installed) against the left rear corner of the assembly with the wire tie from the parts bag.

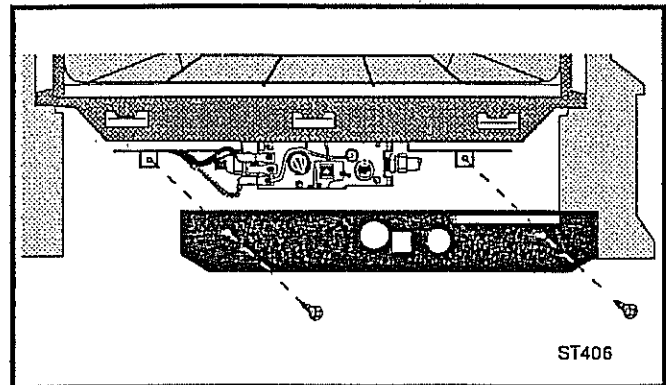

Fig. 56 Replace the valve cover plate with two 1/2" sheet metal screws.

Install the Log Set

1. Remove the logs from their container, and inspect each piece for damage. **DO NOT INSTALL DAMAGED LOGS.**
2. Install the Rear Log (1) by engaging it with the pins on the sheet metal shelf at the back of the firebox. (Fig. 57)
3. Install the Left and Right Middle logs (2 & 3) by engaging holes on their bottoms with pins on the burner brackets. (Fig. 57)
4. Push the burner assembly fully toward the rear, by hand. Place the two front Ember Log sections (4 & 5) in the slot at the front of the firebox, shown in Figure 58. Reposition the burner tray fully forward against the Ember Logs.
5. Loosely sprinkle some of the Lava Rocks sparingly on top of the burner between the Ember Logs and the Middle Logs. Do not place any lava rocks behind the middle logs. See 6, Fig. 58.
6. Engage the Top Log (7) with the Rear Log and the pins on the Middle Logs as shown in Figure 59.

Light the Pilot

Follow the instructions on pages 30-31 to light the Pilot before you reinstall the glass panel onto the stove.

Replace the Glass Panel

Position the glass panel frame against the firebox placing its bottom edge on the brackets at the bottom face of the firebox. Push the assembly against the firebox, and close the latches firmly around the retainer pins on the firebox top.

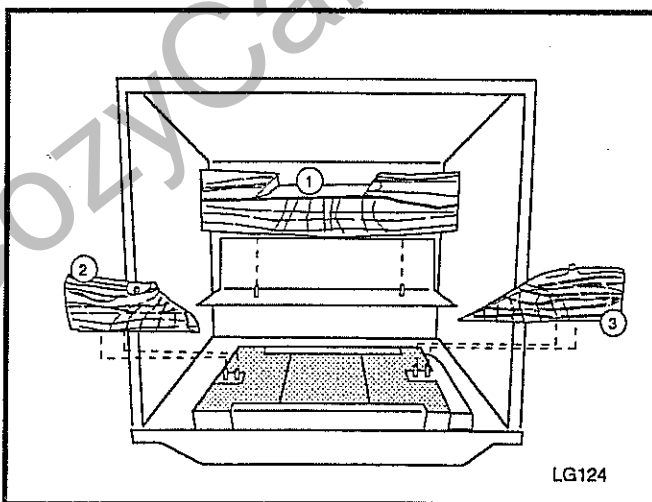

Fig. 57 Install the back, left and right logs.

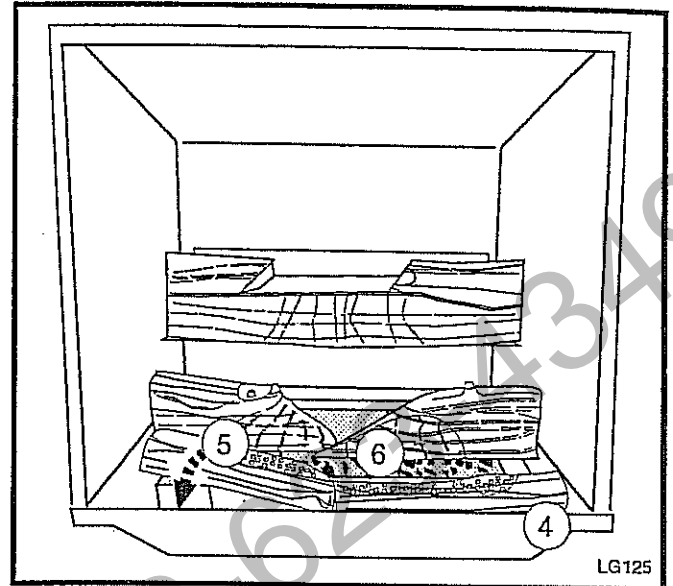

Fig. 58 Install the ember logs, and the lava rocks.

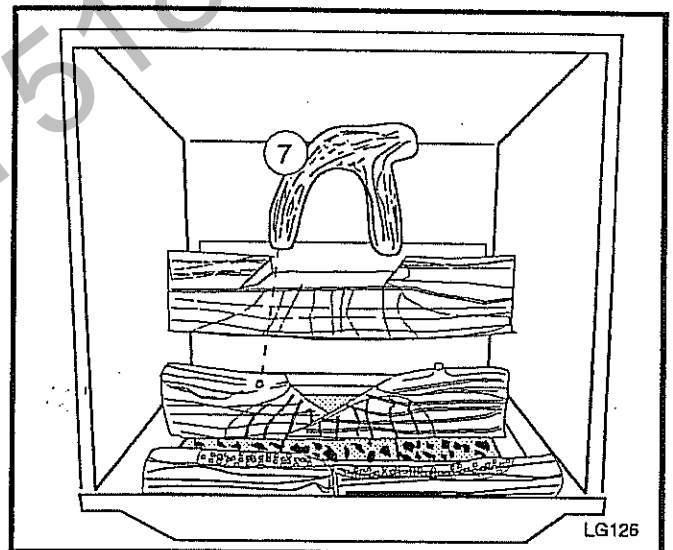

Fig. 59 Install top log.

Install the Front and Top Plates

1. Grasp the Front Plate and lift it into position, engaging the two steel tabs at the upper corners behind the adjacent bosses in the Side Plates. (Fig. 60) Seat the Front against the Sides so that the tabs at the bottom lip engage with the notches in the edge of the stove base.

When properly installed, the bottom of the Front Plate cannot be pulled away from the sides without also lifting it up.

2. If you are installing optional Warming Shelves, do so now, according to the instructions supplied with that kit.
3. Install the Top Plate. The upper edges of the side plates should seat into the channel on the underside of the Top. (Fig. 61)

This completes installation of the PDV20 Gas Heater.

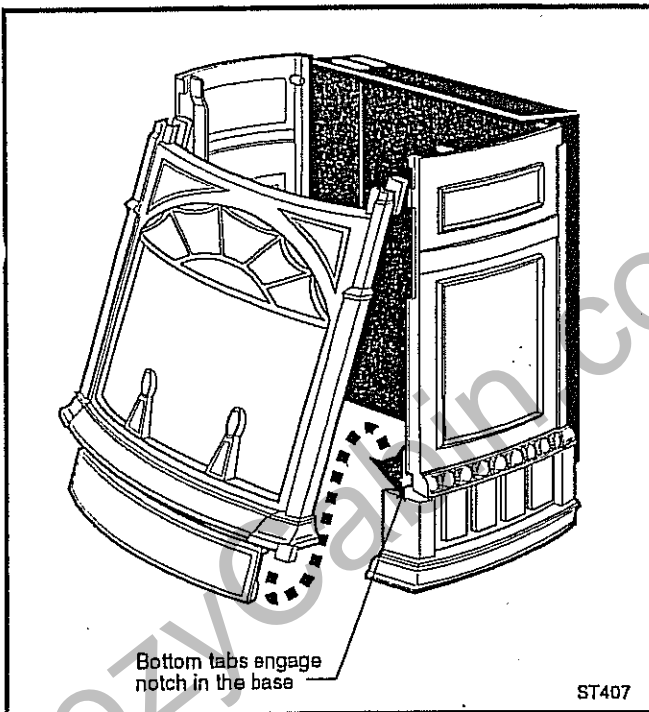

Fig. 60 Install the front plate.

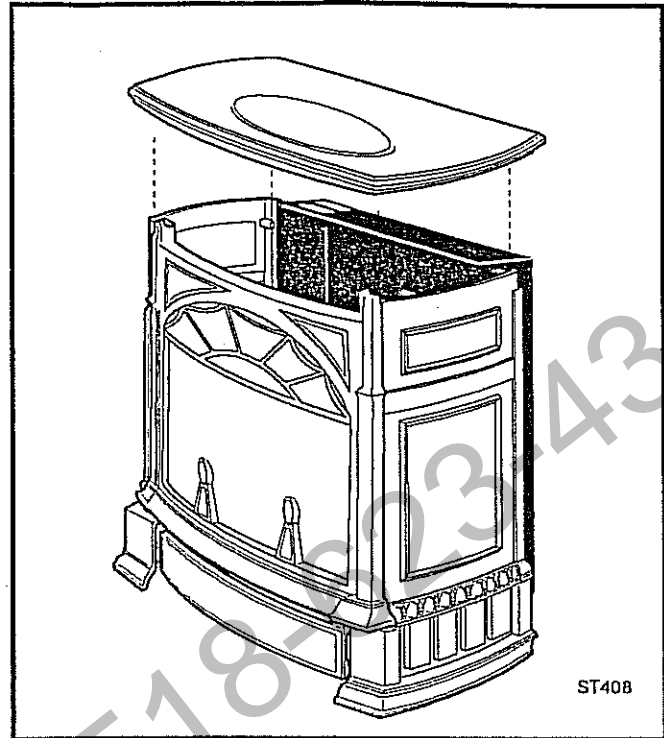

Fig. 61 Install the top plate.

Operation

Your First Fire

Read these instructions carefully and familiarize yourself with the burner controls shown in Figures 62-63. Locate the pilot assembly, Figure 63. Follow the lighting instructions on Page 30-31 exactly.

During the first fire, it is not unusual to smell some odor associated with new logs, paint and metal being heated. Odors should dissipate within an hour or so, however, you can open a window to provide fresh air to alleviate the condition.

Pilot and Burner Inspection

Each time you light your heater check that the pilot flame and burner flame pattern are as shown in Figures 64-65. If flame patterns are incorrect, turn the heater off. Contact your dealer or a qualified gas technician for assistance. Do not operate the heater until the pilot flame is correct.

Follow regular maintenance procedures as described on pages 33-36.

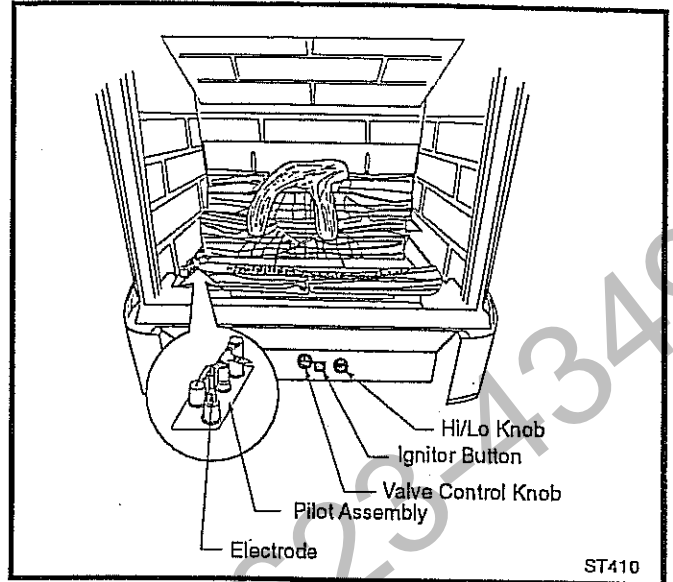

Fig. 63 Pilot assembly location.

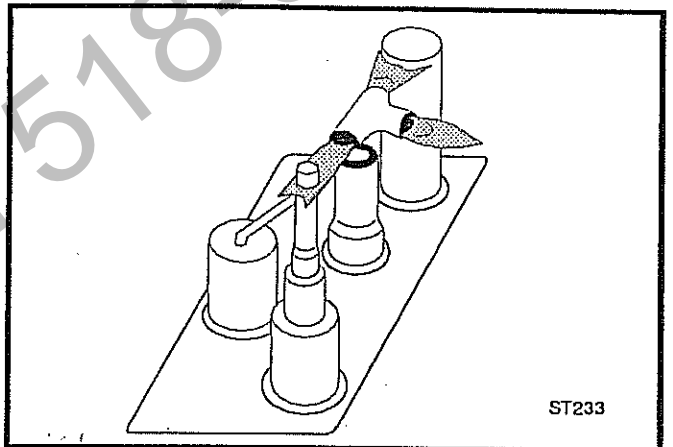

Fig. 64 Correct pilot flame pattern.

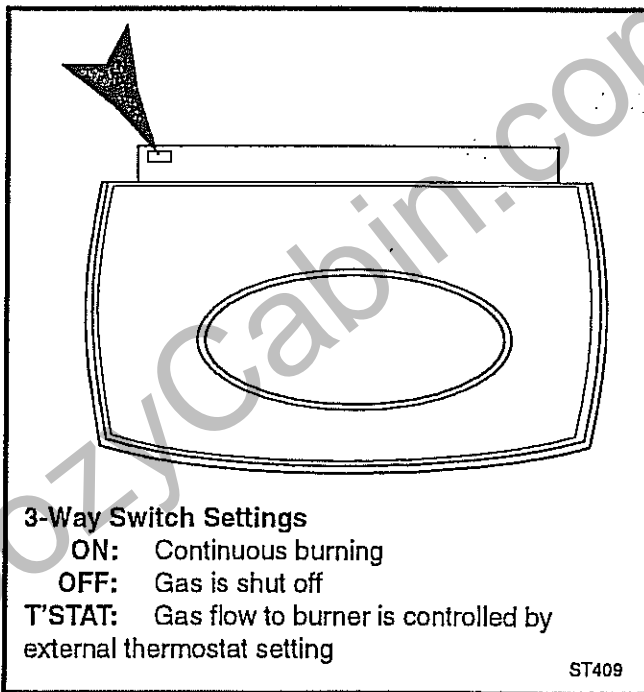

Fig. 62 3-way control switch location.

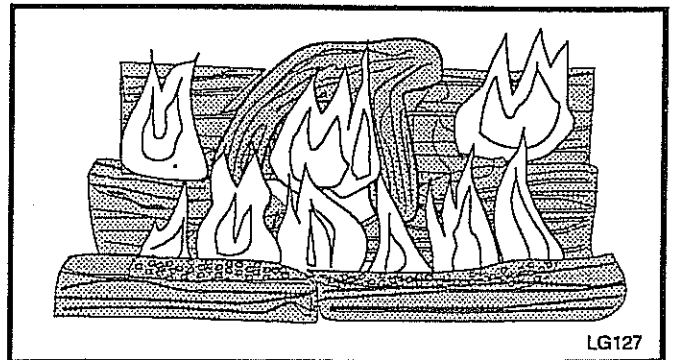

Fig. 65 Correct burner flame pattern.

Lighting the Fire

The control valve includes a variable regulator that lets you adjust the gas input rate. To gain access to the gas control valve, swing open the valve control Access Door below the firebox opening.

1. Turn the wall thermostat, if any, to its lowest setting.
2. If the pilot is already lit, proceed to "Relighting the Fire" below.

Remove the stove front and the glass panel as shown on page 30. Wait fifteen (15) minutes to clear out any residual gas before trying to light the pilot. Before lighting the pilot, make sure that the valve knob is in the OFF position by pushing in the gas control knob slightly and turning it clockwise to "OFF." Also, put the ON/OFF remote rocker switch, located at the rear of the appliance, in the OFF position.

3. Turn the Regulator Control Knob to HI.

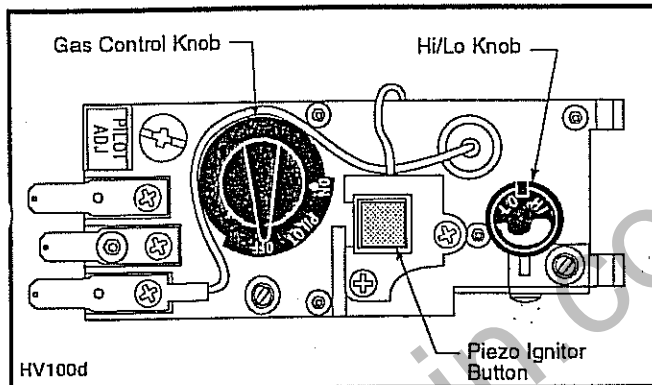

Fig. 66 Valve controls (cover plate removed).

4. Smell for gas. Inspect the unit for any obvious sign of damage or deterioration. If it is damaged, do not attempt to light the pilot or burner.
5. Locate the pilot under the front log in the lower forward left hand corner of the firebox. When lit, the pilot will produce a small steady flame.
6. Turn the knob on the gas control counterclockwise to "PILOT."
7. Light the pilot by pushing the control knob all the way in and holding it there. Immediately push the piezo ignitor button; push it more than once if required to light the pilot. The ignitor produces a small spark at the pilot assembly. Continue to hold the control knob in for about one (1) minute after the pilot is lit. Then, release the knob and it will pop back up. The pilot should remain lit.

NOTE: Once the pilot has been lit, it will remain lit continuously. Replace the glass and the front panel.

8. Turn the gas control knob counterclockwise to "ON."
9. Place the ON/OFF rocker switch in the ON position and continue to watch the fire until the entire unit is lit. Adjust the Regulator Control Knob to maintain the desired level flame intensity.
10. Adjust the wall thermostat, if any, to your desired heat level.

CAUTION

If the entire fire is not lit within five (5) seconds of turning the remote rocker switch ON, immediately push the remote rocker switch to OFF. Allow fifteen (15) minutes for the gas to clear from the firebox. Repeat from Step 2. If unsuccessful again, completely turn off all gas to the Pinnacle. Call your local Dealer.

WARNING

Do not attempt to decrease the gas flow to the Pinnacle by closing the manual gas supply valve. A hazardous condition may result when operating or attempting to operate the Pinnacle if this valve is in a position other than fully open.

Turning Off the Fire

1. Simply push the rocker switch to OFF. The pilot will remain on. You can leave the pilot running.

NOTE: If you do not intend to operate the unit for an extended period of time, it is a good idea to turn the gas control knob to OFF and to turn the manual gas valve on the supply line to OFF as well.

Re-lighting the Fire

1. Check to see if the pilot is on.
2. Turn the rocker switch to ON and watch to be sure the entire burner lights.

FOR YOUR SAFETY READ BEFORE LIGHTING

WARNING: IF YOU DO NOT FOLLOW THESE INSTRUCTIONS EXACTLY, A FIRE OR EXPLOSION MAY RESULT CAUSING PROPERTY DAMAGE, PERSONAL INJURY, OR LOSS OF LIFE.

- A. This appliance has a pilot. When lighting the pilot, follow these instructions exactly.
- B. **BEFORE OPERATING** smell all around the appliance area for gas. Be sure to smell next to the floor because some gas is heavier than air and will settle on the floor.

WHAT TO DO IF YOU SMELL GAS:

- Shut off all gas to the appliance.
 - Do not try to light any gas appliance.
 - Do not touch any electric switch; do not use any phone in your building.
 - Immediately call your gas supplier from a neighbor's phone. Follow the gas supplier's instructions.
 - If you cannot reach your gas supplier, call the fire department.
- C. Use only your hand to turn the gas control knob. Never use tools. If the knob will not turn by hand, don't try to repair it. Call a qualified service technician. Force or attempted repair may result in a fire or explosion.
- D. Do not use this appliance if any part has been under water. Immediately call a qualified service technician to inspect the appliance and to replace any part of the control system and any gas control that has been under water.

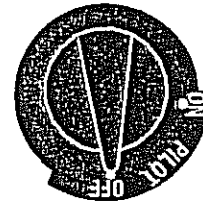

LIGHTING INSTRUCTIONS

1. **STOP!** Read the safety information above on this label.
2. Turn off all electric power to the appliance.
3. Turn the thermostat to the lowest setting, (if applicable).
4. Place the OFF/ON/T'STAT switch in the OFF position.
5. Push in gas control knob slightly and turn clockwise  to "OFF."



Control Knob

NOTE: Knob cannot be turned from "PILOT" to "OFF" unless knob is pushed in slightly. Do not force.

6. Remove the stove's front plate according to the instructions on Page 30. Remove the glass panel according to the instructions on Page 30.
7. Wait fifteen (15) minutes to clear out any gas. If you then smell gas, **STOP!** Follow "B" in the safety information above on this label. If you don't smell gas, go to the next step.
8. Turn knob on gas control counterclockwise  to "PILOT."
9. Find pilot. The pilot is located below the logset in the forward lower left area of the firebox.
10. Push in control knob all the way and hold in. Immediately light the pilot by pushing the ignitor button. Continue to hold the control knob in for about one (1) minute after the pilot is lit. Release knob and it will pop back up. Pilot should remain lit. If it goes out, repeat steps 5 through 9.
 - If knob does not pop up when released, stop and immediately call your service technician or gas supplier.
 - If the pilot will not stay lit after several tries, turn the gas control knob to "OFF" and call your service technician or gas supplier.
11. Replace the glass panel and front according to the instructions on Page 31.
- 12 Turn gas control knob counterclockwise  to "ON."
13. Place the OFF/ON/T'STAT switch in the ON or T'STAT position.
14. Turn on all electric power to the appliance.

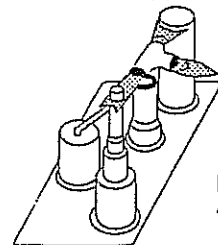

Pilot Assembly

TO TURN OFF GAS TO APPLIANCE

1. Turn off all electric power to the appliance if service is to be performed.
2. Push in gas control knob slightly and turn clockwise  to "OFF."

NOTE: Knob cannot be turned from "PILOT" to "OFF" unless knob is pushed in slightly. Do not force.

Troubleshooting / Honeywell #8420 Gas Control System

NOTE: Before troubleshooting the gas control system, be sure the external gas shut-off is in the "ON" position.

WARNING: REMOVE THE GLASS PANEL BEFORE PERFORMING ANY GAS CONTROL SERVICE WORK.

SYMPTOM	POSSIBLE CAUSES	CORRECTIVE ACTION
1. Spark ignitor will not light.	A. Defective or misaligned electrode at the pilot.	Using a match, light pilot. If pilot lights, turn off pilot and push the ignitor button again. If pilot will not light, check gap at electrode and pilot - it should be 1/8" to have a strong spark.
	B. Defective ignitor (push button).	Push piezo ignitor button. Check for spark at electrode and pilot. If there is no spark at the pilot, and electrode wire is properly connected, replace ignitor.
2. Pilot will not stay lit after carefully following the lighting instructions.	A. Defective pilot generator (thermocouple)	Check pilot flame. It must impinge on thermocouple or thermopile. Note: this pilot burner assembly uses both a thermocouple and a thermopile. The thermocouple operates the pilot flame. Tighten the thermocouple. The thermopile operates the main valve (On and Off). Clean and/or adjust pilot for maximum flame impingement on thermocouple and thermopile.
	B. Defective automatic valve operator.	Turn valve knob to 'Pilot'. Maintain flow to pilot; millivolt meter should read greater than 10mV. If the reading is okay and the pilot does not stay on, replace the gas valve. Note: An interrupter block (not supplied) must be used to conduct this test.
3. Pilot lights, no gas to burner, valve knob ON, remote switch (rocker switch) ON.	A. Remote switch or wires defective.	Check rocker switch and wires for proper connection. Use jumper wires across terminals at rocker switch. If burner lights, replace rocker switch. If okay, use jumper wires across rocker switch wires at the valve; if burner lights, wires are faulty or connections are bad.
	B. Thermopile may not generate sufficient voltage.	1. Be sure wire connections from thermopile at gas valve terminals are tight and thermopile is fully inserted into pilot bracket.
		2. One of the rocker switch wires may be grounded. Remove rocker switch wires from valve terminals. If burner now stays lit, trace rocker switch wiring from ground. It may be grounded to the appliance or the gas supply line.
		3. Check the thermopile with a millivolt meter. Take reading at thermopile ("TP" and "TP/TH") terminals of gas valve. Should read 325 millivolts minimum while holding valve knob depressed in PILOT position and with rocker switch OFF. Replace faulty thermopile if reading is below specified minimum.
C. Plugged burner orifice.	Check burner orifices for debris, and remove.	
D. Defective automatic valve operator.	Turn knob to ON, place rocker switch to ON, millivolt meter should read greater than 100 mV. If the reading is okay and the burner does not light, replace the valve.	
4. Frequent pilot outage.	A. Pilot flame may be too low or high, (blowing or lifting), causing the pilot to drop out.	Clean and/or adjust pilot flame for maximum flame impingement on thermocouple and thermopile.
	B. Possible blockage of the vent terminal.	Check the vent terminal for blockage.

Maintenance

Your PDV20 Gas Heater will provide years of service with minimal upkeep. The following procedures will help ensure that your stove continues to function properly.

Annual System Inspection

Have the entire heater and venting system inspected annually by a qualified gas technician. Replace any worn or broken parts.

Logset and Burner / Cleaning and Inspection

Cleanliness is critical to the proper function of the heater. The log set and burner must all be kept free of dust and unobstructed by debris. Inspect these areas before each use and clean as necessary.

1. Turn the burner OFF and let the heater cool completely before cleaning.
2. Lift the Front Plate up and then swing the bottom out to disengage it from the heater shell. (Fig. 67)
3. Pivot the two frame latches to disengage the retainer bolts at the top corners of the glass frame. (Fig. 68) Carefully remove the glass and frame assembly and place it out of the way on a flat, padded surface such as a counter protected by a towel.
4. Carefully inspect the Logs for damage. Contact your local dealer if any damage is evident. **DO NOT OPERATE THE HEATER WITH DAMAGED LOGS.** Use a soft bristled brush to sweep dust or debris from the Logs, Pilot and Burner. Use care as the Logs are fragile and susceptible to damage. **DO NOT USE A VACUUM TO CLEAN THE LOGS OR BURNER.**
5. Replace the Glass panel and frame assembly.
6. Replace the Front Plate.

Care of Painted Cast Iron

An occasional dusting with a dry rag will help keep the *painted surfaces* looking new. Use high-temperature stove paints, available through your local dealer, to touch-up areas as needed. Clean areas to be painted with a wire brush and be sure to cover the Logs, Burner and Valve assembly, glass and frame assembly, and cover plate. Apply the paint sparingly; two light coats of paint will give better results than a single heavy coat.

CAUTION

Turn the Pilot **OFF** before Painting. Allow the heater to cool completely before painting.

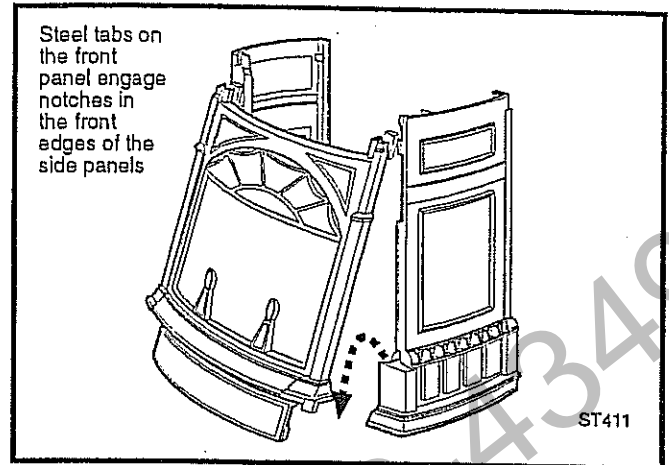

Fig. 67 Remove the front plate.

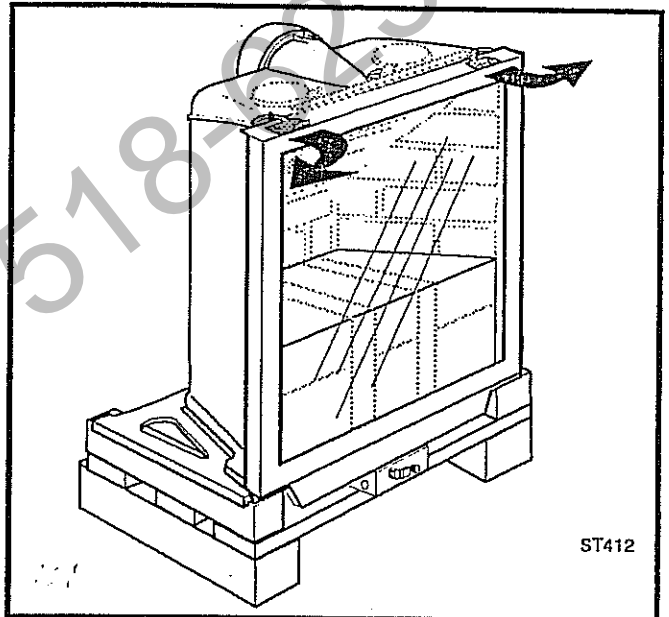

Fig. 68 Release the latches to release the glass frame.

Care of Porcelain Enamelled Surfaces

Clean *porcelain enamel surfaces* with a soft, damp cloth. Do not use abrasive cleaning agents. If necessary, use only a cleaning agent formulated especially for use on porcelain enamel surfaces.

Cleaning the Glass

Clean the glass only with a soft, damp cloth. Do not use abrasive cleaning agents.

WARNING: Let the glass cool completely before attempting to clean.

Glass Replacement

Replace glass only with Vermont Castings Part # 160-1691. Refer to Figures 67 and 68, and previous instructions for removal of the damaged glass panel.

Gasket Replacement

The PDV20 Gas Heater uses a 'tadpole' type gasket to seal between the glass panel and the frame. In time, this gasket can become brittle and compressed and should be replaced. New gasket is available from your dealer; specify part number 120-3702.

Shut off the gas supply and allow the stove to cool. Wear safety goggles and a dust mask.

1. Remove the Front, Glass Frame and Glass Panel. (Figs. 67-68) Remove the old gasket. (Fig. 69) Use a razor blade to separate the glass and gasket from the frame, and to clean the glass of any remaining cement or bits of gasket. Use a cold chisel if necessary.
2. Determine the correct length of gasket by laying it out around the edge of the glass. Allow an extra 1-2" (25-50 mm), and mark the spot to be cut. Use a utility knife.
3. Starting on a long edge, remove about 6" of the protective paper strip and apply the flat adhesive face of the gasket around the outside-facing edge of the panel. Continue around the panel, applying about 6" at a time and being careful to not stretch the material. Do not overlap the gasket ends. (Fig.69)
4. Apply a thin bead of silicone rubber sealant all around the perimeter of the frame opening, as shown in Figure 70.
5. Orient the glass panel so that the *flat side* of the gasket contacts the sealant within the frame. The glass panel should be centered over the opening and resting on the bottom shelf of the frame. (Fig. 71)
Pinch the rounded inside-facing gasket material to bulk it up.
6. Replace the frame and glass assembly on the front of the stove, and fasten it by pivoting the two latches to engage the retainer posts at the top corners of the firebox.
7. Replace the front, holding the bottom edges slightly away from the stove while engaging the steel tabs at the top with notches in the stove's side panels. (Fig. 67) Swing the bottom of the front panel into place against the sides panels, and engage prongs on the bottom corners with notches in the tops of the stove legs. The front is in place properly when you cannot pull it toward yourself without also lifting it.

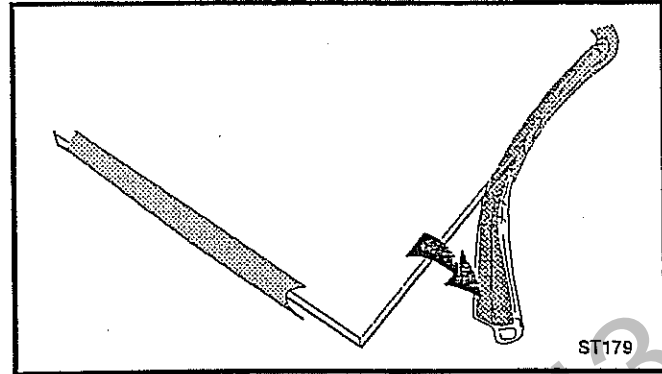

Fig. 69 Wrap the gasket material around the outside edge of the glass.

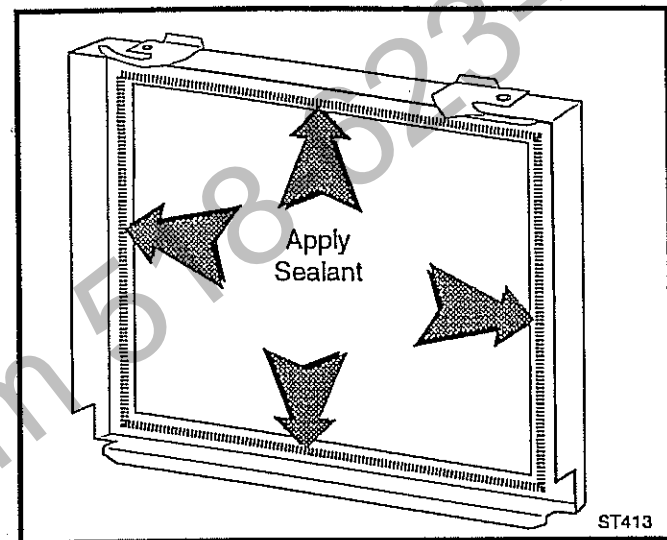

Fig. 70 Apply a bead of sealant all around the window opening.

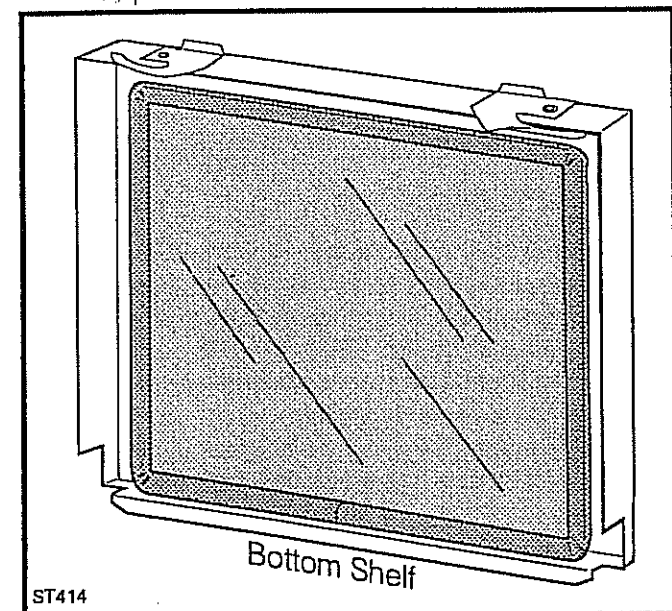

Fig. 71 Rest the glass panel on the bottom centered within the frame.

Inspect the Vent System Annually

Have the vent system inspected annually by a qualified technician. Shut off the main gas supply before inspecting the system. Both the inner exhaust pipe and the outer combustion supply pipe must be checked to confirm that they are unblocked and in good condition. Inspect for dust buildup, corrosion, or any sign of deterioration or deposits that could interfere with the flow of intake air and exhaust gases. Clean the system if needed. Refer to the vent maker's instructions for re-assembly and resealing procedures.

Check the Gas Flame Regularly

To ensure that the stove is operating properly, check the flames periodically to confirm that they match Figure 72. The flame pattern should be evenly distributed throughout the log set. The flames will be blue during the first 15-20 minutes of operation, and will gradually turn to yellow after that.

Do not use your stove if the flame pattern differs from that shown here. Contact your dealer or a qualified technician for help.

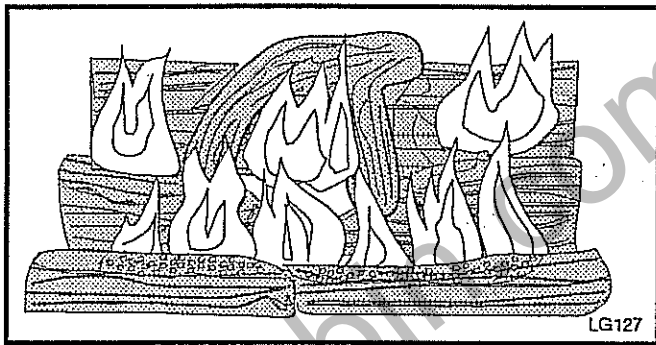

Fig. 72 Correct flame pattern.

Stove Disassembly

If there is ever a need to remove the firebox assembly from the stove shell, support the firebox with solid blocks about 6" (150mm) tall under the outer edges of the firebox base. Do not set the firebox assembly directly on the floor; this can damage the control valve and/or the gas lines from the valve to the firebox.

Before removing the firebox from the shell, shut off the gas supply at the valve upstream of the heater. Remove the control panel from the forward base of the firebox; let it lie on the floor under the heater. Disconnect the on/off switch wires from the valve. If the assembly includes the optional fan, disconnect the fan snapstat from the back edge of the firebox base. See the Fan Installation Section for details.

Slide the firebox over the control panel to remove it. Disconnect the gas line from the control valve. Only a

qualified gas service technician should disconnect and re-connect the gas line.

On re-installation follow the assembly procedures in the Assembly chapter of this manual.

Burner Adjustment

Two air shutters, located on the burner, are set at the factory for either Propane or Natural Gas and should not need adjustment. However, installation characteristics vary, and adjustment may be needed to improve flame picture or eliminate sooting. Generally, the shutter openings should be set as shown in Figure 73. Closing the shutters (less air) produces a more yellow flame, more prone to sooting. Opening the shutters, (more air) produces a bluer flame. After adjusting the shutters, the stove should be burned for at least one hour to see the effect of the setting change. If soot appears on the glass, logset, or firebox, the air shutters must be opened to eliminate the condition. **Adjustment should be done only by a qualified gas technician.**

1. Shut off the gas supply to the stove. Turn off all power to the stove. Remove the front panel, the glass, and the log set.
2. Remove the left and right log brackets. Lift the left end of the burner, slide it to the left, and lift it out of the firebox to access the air shutters on the right end of the burner.
3. Loosen the shutter locking screws enough to adjust the setting as needed and re-tighten. (Fig. 73)
4. Set the burner back into the firebox, taking care to ensure that the ends of the shutter tubes fully engage with the injectors.
5. Replace the log brackets, logs, glass, and front panel. Refer to the assembly chapter for details.

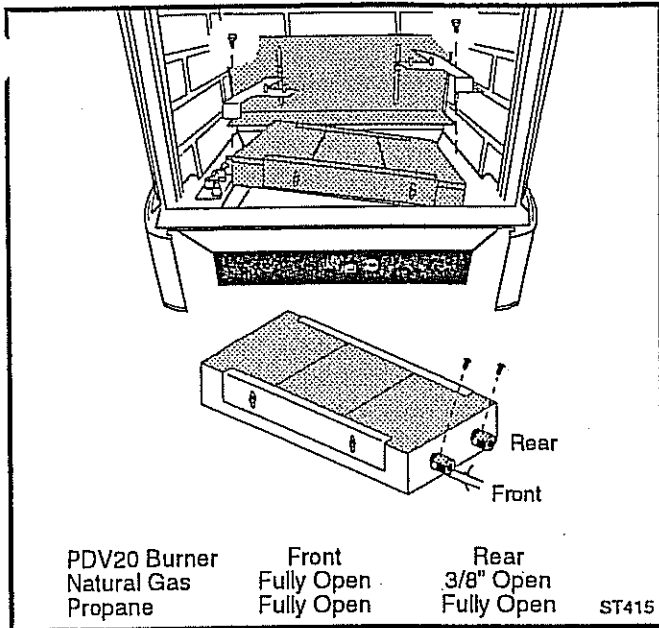

Fig. 73 Burner removal and air shutter settings.

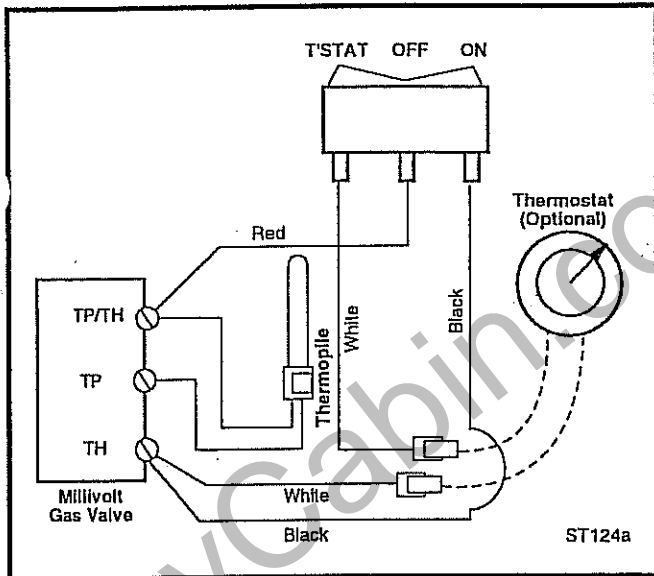

Fig. 74 PDV20 firebox circuit.

Note: If any of the original wire, as supplied with the appliance, must be replaced, it must be replaced with Type SF-2, 200°C wire or its equivalent.

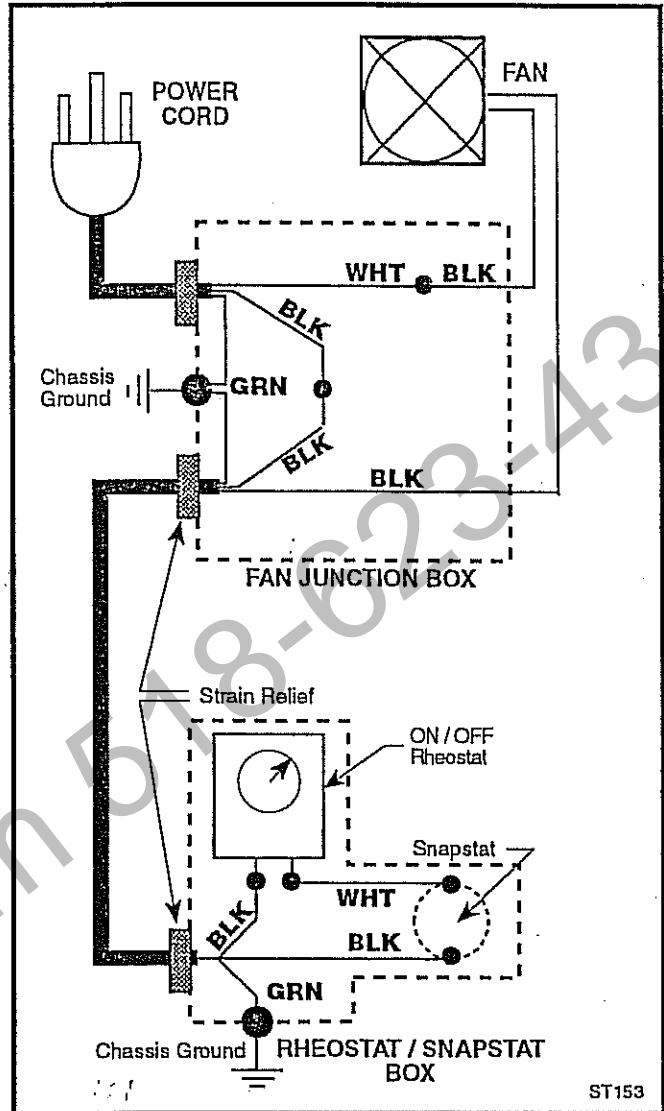

Fig. 75 PDV20/ convection fan circuit.

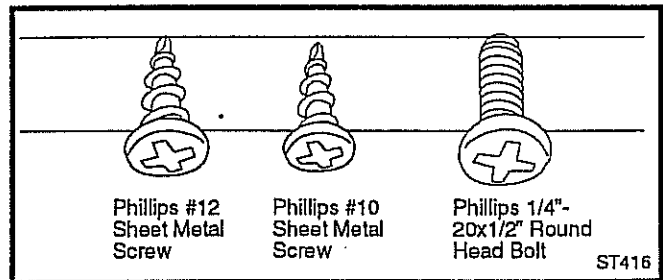
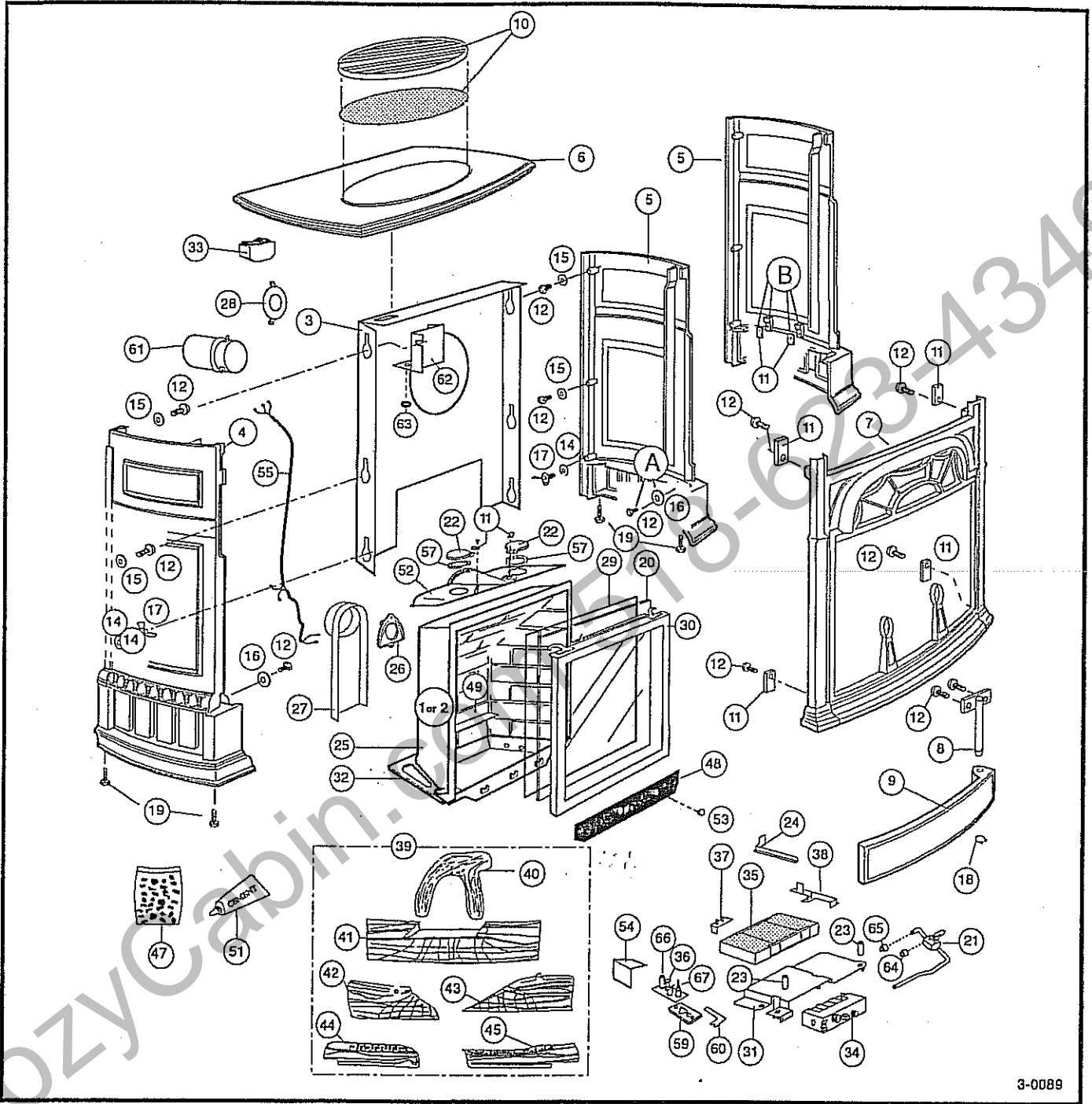

Fig. 76 Hardware chart.



3-0089

Vermont Castings, Majestic Products reserves the right to make changes in design, materials, specifications, prices and discontinue colors and products at any time, without notice.

Pinnacle Direct Vent PVDV20

Item/Model Number	Part Number
1. Firebox Assembly / NG	000-2938
2. Firebox Assembly / LP	000-2939
3. Rear Shroud	30000088
4. Left End ¹	
Type A Fasteners (Item 5)	1301116 ²
Left End ¹	
Type B Fasteners (Item 5)	30000199 ²

Item/Model Number	Part Number
5. Right End ¹	
Type A Fasteners (Item 5)	1301115 ²
Right End ¹	
Type B Fasteners (Item 5)	30000200 ²
6. Top Plate ¹	30000361
7. Front Plate ¹	1301129
8. Control Door Hinge	1601670

PDV20 (continued)

Item/Model Number	Part Number
9. Control Door	1301087
10. Grille	30000393
Grille Mesh	30000508
11. Steel Tab	1601488
12. 1/4-20 x 3/8" Phillips Screw	1200993
13. 1/4-20 x 1/2" Hex Head Screw	1201338
14. Washer, Wingbolt	1202470
15. Washer	1202474
16. Fender Washer	1202527
17. 1/4-20 Wingbolt	1203110
18. Snap Ring	1201987
19. Levelling Bolt	1201745
20. Glass	1601691
21. Manifold Tube Assembly	20000663
22. Relief Door	30000060
23. Spacer	30000139
24. Air Deflector	30000152
25. Firebox	30000057
26. 4" Flue Outlet	30000083
27. Air Passage	30000084
28. Flue Restrictor Plate	30000253
29. Glass Panel Gasket	1203702
30. Glass Frame Assembly	30000127
31. Bottom Heat Shield/ Valve Bracket	30000211
32. Firebox Bottom	30000227
33. On/Off Switch	1601597
34. Control Valve, Honeywell VS8420, NG	20000541
Control Valve, Honeywell VS8420, LP	20000572
35. Burner Assembly, NG	30000259
Burner Assembly, LP	30000260

Item/Model Number	Part Number
36. Pilot, NG	20001115
Pilot, LP	20001116
37. Left Log Bracket	30000243
38. Right Log Bracket	30000209
39. Gas Log Set (Includes #40-45)	30000252
40. Top Log	30000262
41. Rear Log	30000265
42. Middle Left Log	30000263
43. Middle Right Log	30000264
44. Left Ember Log	30000135
45. Right Ember Log	30000134
47. Lava Rock (1 Package)	57897
48. Control Valve Cover Plate	30000210
49. Rear Log Bracket	30000208
51. Tube of Cement	1206122
52. Firebox Cap	30000085
53. Hole Plug	1600561
54. Pilot Shield	30000301
55. Wire Harness	1601913
57. Relief Door Gasket	1203687
58. 1/4-20 x 3/8" Phillips Pan Hd Bolt	1200993
59. Pilot Gasket	1203685
60. Wind Shield	30000251
61. Starter Pipe	30000245
62. Switch Heat Shield	30000582
63. Switch Heat Shield Bushing	1201896
64. Orifice, Front, NG #56 (.0465)	30000336
Orifice, Front, LP #67 (.032)	30000338
65. Orifice, Rear, NG #50 (.070)	30000337
Orifice, Rear, LP #61 (.039+)	30000335
66. Thermopile	30000312
67. Thermocouple	30000313

Fuel Conversion Kits

LP to Natural - nonconvertible valve	000-5027
Natural to LP - nonconvertible valve	000-5028
LP to Natural - convertible valve	000-5029
Natural to LP - convertible valve	000-5030

NOTE: In this parts list, and throughout the manual, 'left' and 'right' mean as you face the stove.

¹When ordering exterior parts, be sure to specify color. For Stardance exterior parts, (SDVR) consult your dealer.

²Type B sides will substitute for Type A sides.

For replacement parts, or for information about parts or service, contact your local dealer. For the name of the dealer nearest you, call or write:

Vermont Castings, Majestic Products
410 Admiral Blvd.
Mississauga, Ontario, Canada L5T 2N6
905 670-7885

Appendix

Stardance SDVR (Rear Vent) Installation Requirements

Specifications for using the PDV20 Direct Vent Firebox Models 2938 / 2939 with Stardance Stove Shells 2985, 2986, 2987, 2988, 2989

The PDV20 firebox installs into the Stardance shell in the same manner as the Pinnacle shell as described in the Assembly chapter of this manual.

Use the clearance and dimensional information presented in this Appendix to install the Stardance shell in a rear vent application.

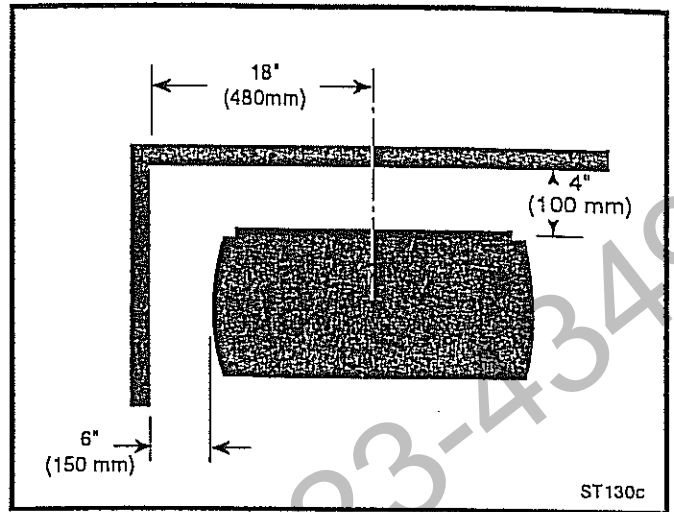

Fig. 78 Stardance shell clearances and SDVR flue collar centerline.

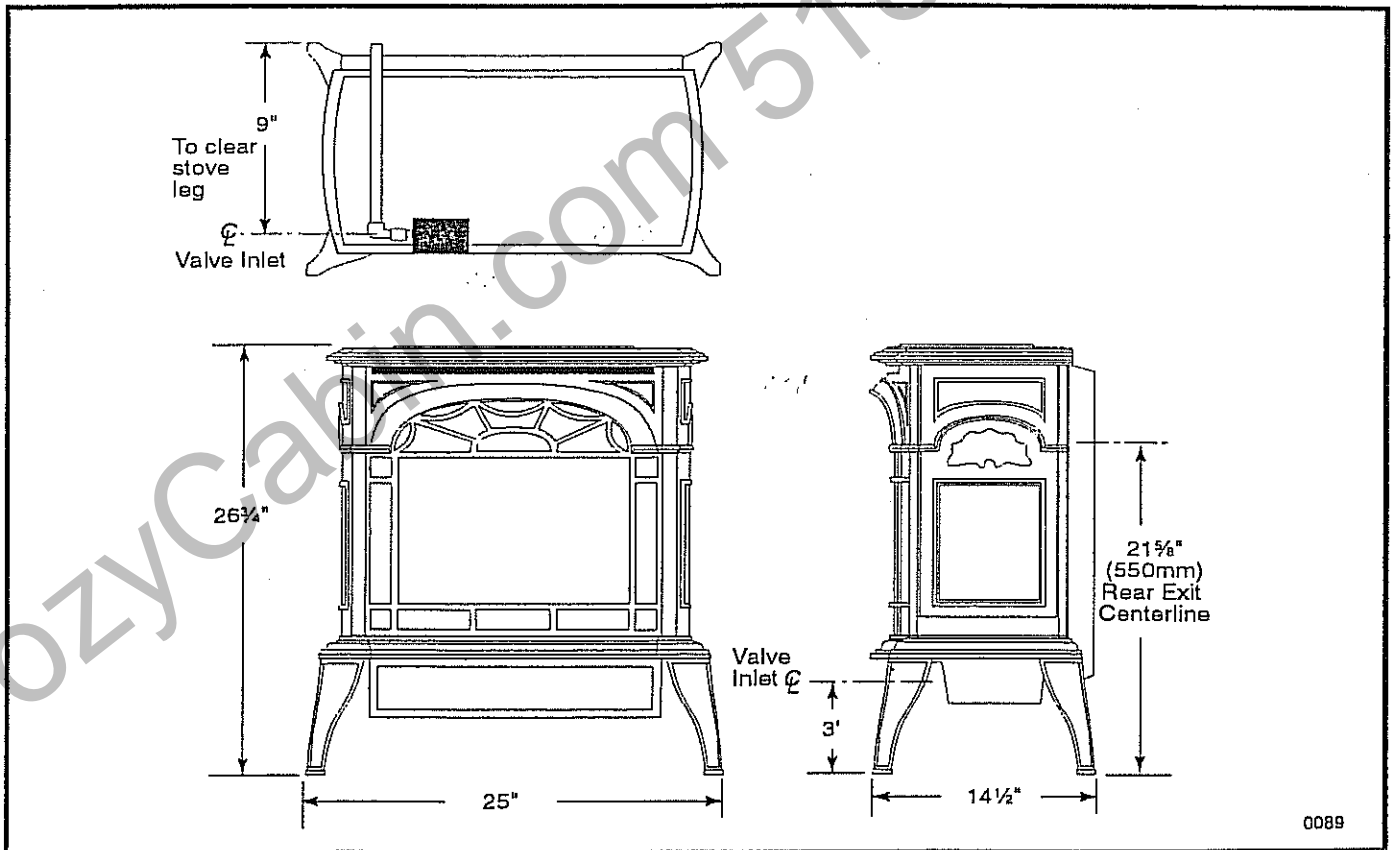

Fig. 77 Stardance shell dimensions.

SDVR Fireplace Vent System Requirements

The illustrations below pertain to fireplace installations and use of the 7TFSCSK Transition Connector. Use the same vent criteria for the Stardance shell as for the Pinnacle shell, except for the clearances and dimensions noted here.

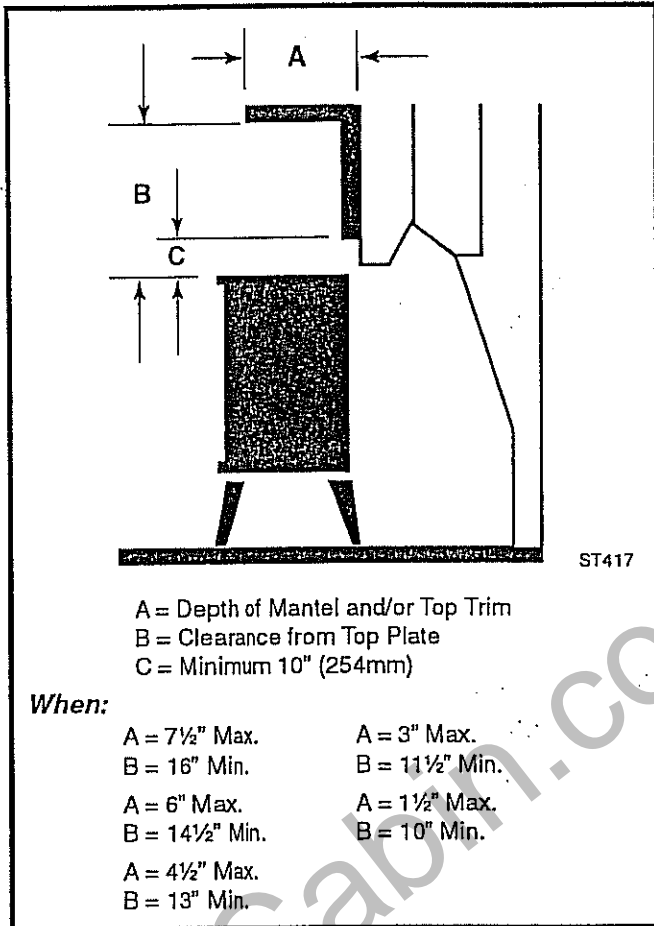

Fig. 79 SDVR mantel clearances.

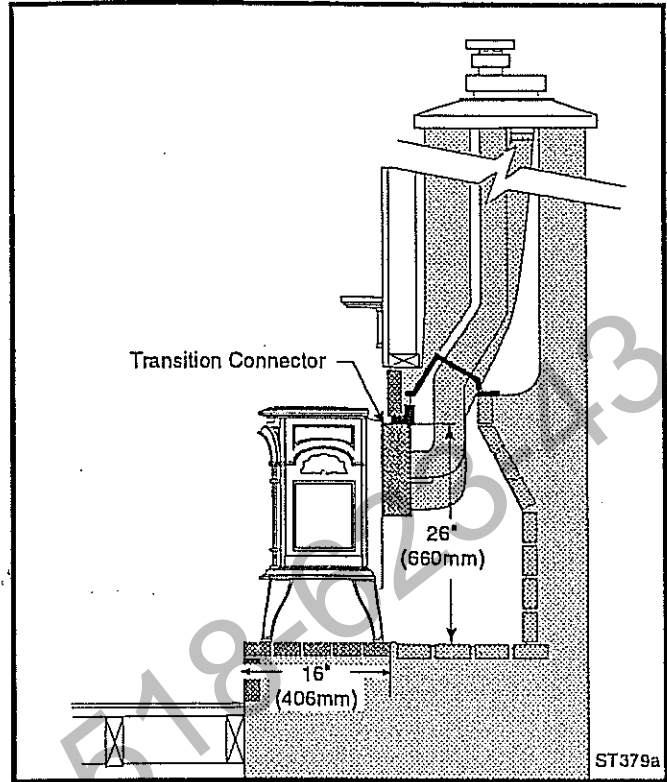

Fig. 80 Minimum fireplace height / minimum hearth depth.

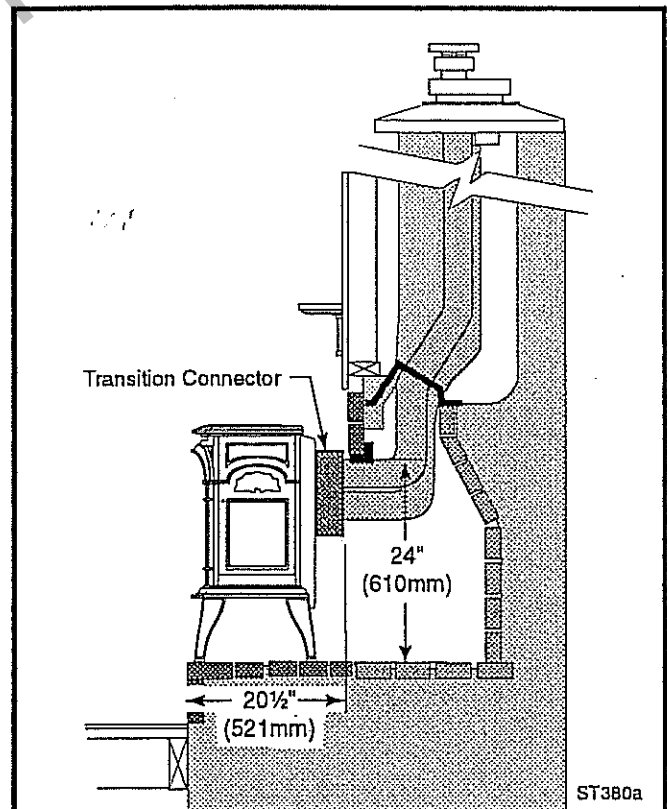

Fig. 81 Minimum fireplace opening height / minimum hearth depth required - transition connector forward of fireplace face.

SDVR Through the Wall Installation

Follow the guidelines and procedures for installing the Minimum Side Wall Vent Kit 7TF5RSK as detailed in the Assembly chapter, page 15. Note the clearance and wall opening dimensions for the SDVR application in Figure 82.

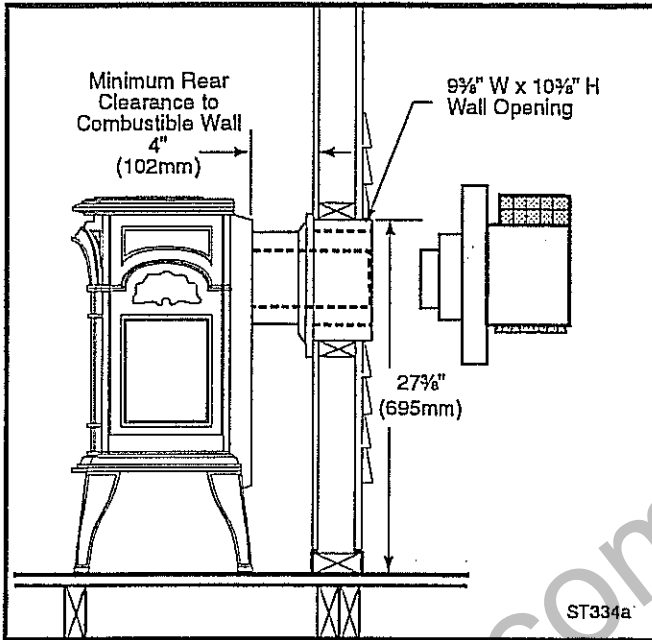

Fig. 82 7TF5RSK rear vent kit. Through the wall installation; wall opening height. Note that the vent is not vertically centered within the wall opening.

CozyCabin.com 518-623-4349

Warranty

Limited Three Year Warranty

Vermont Castings, Majestic Products warrants that this Radiance Natural Vent Room Heater will be free of defects in material and workmanship for a period of three years from the date you receive it, except that the glass door panel, ceramic logs, and gasketing shall be warranted for one year as described below.

Vermont Castings, Majestic Products will repair or replace, at its option, any part found to be defective upon inspection by a Vermont Castings, Majestic Products Authorized Dealer. The customer must return the defective part or the stove, with shipping prepaid, to the Authorized Dealer or pay for any Authorized Dealer in-home travel fees or service charges for in-home repair work. It is the dealer's option whether the repair work will be done in the customer's home or in the dealer's shop. If, upon inspection, the damage is found to be the fault of the manufacturer, repairs will be authorized at no charge to the customer for parts and/or labor.

Any Radiance Natural Vent Room Heater or part thereof that is repaired or replaced during the limited warranty period will be warranted for a period not to exceed the remaining term of the original limited warranty or six (6) months, whichever is longer.

Limited One Year Warranty

The following parts of the Radiance Natural Vent Room Heater are warranted to be free of defects in material and workmanship for a period of one year from the date you receive it. These parts are the glass panel, ceramic logs, and gasketing. Any of these items found to be defective will be repaired or replaced at no charge, upon the return of said part to a Vermont Castings Authorized Dealer with postage prepaid.

Exclusions and Limitations

1. This warranty is transferable; however, proof of original purchase is required.
2. Vermont Castings, Majestic Products offers no warranty on chipping of enamel surfaces. Inspect your Radiance Room Heater prior to accepting it for any damage to the enamel.
3. This warranty does not cover misuse of the Radiance Natural Vent Room Heater as described in the Owner's Guide, nor does it cover a Radiance Natural Vent Room Heater that has been modified unless authorized by a Vermont Castings, Majestic Products representative in writing.
4. This warranty does not cover a stove repaired by someone other than either a Vermont Castings, Majestic Products Authorized Dealer or an authorized, qualified gas agency.
5. Damage to the unit while in transit is not covered by this warranty but is subject to claim against the common carrier. Contact the Vermont Castings, Majestic Products Authorized Dealer from whom you purchased your Radiance Room Heater. (Do not operate the Radiance Room Heater as this may negate the ability to process the claim with the carrier.)
6. Claims are not valid where the installation does not conform to local building and fire codes or, in their absence, to the recommendations in the Owner's Guide.

7. Vermont Castings, Majestic Products shall have no obligation to enhance or update any unit once manufactured.

IN NO EVENT SHALL VERMONT CASTINGS, MAJESTIC PRODUCTS BE LIABLE FOR INCIDENTAL AND CONSEQUENTIAL DAMAGES. ALL IMPLIED WARRANTIES, INCLUDING THE IMPLIED WARRANTIES OF MERCHANTABILITY AND FITNESS, ARE LIMITED TO THE DURATION OF THIS WRITTEN WARRANTY. THIS WARRANTY SUPERSEDES ALL OTHER ORAL OR WRITTEN WARRANTIES. Some states do not allow the exclusion or limitations of incidental and consequential damages or limitations on how long an implied warranty lasts, so the above limitations may not apply to you. This warranty gives you specific rights and you may have other rights which vary from state to state.

8. The salt air environment of coastal areas or a high humidity environment can be corrosive to the porcelain enamel finish. These conditions can cause rusting of the cast iron beneath the porcelain enamel finish which will cause the porcelain enamel finish to flake off.

How To Obtain Service

If a defect is noted within the warranty period, the customer should contact a Vermont Castings, Majestic Products Authorized Dealer with the following information:

1. Name, address, and telephone number of the purchaser.
2. Date of purchase.
3. Serial number from the label on the back of the stove.
4. Nature of the defect or damage.
5. Any relevant information or circumstances, i.e., installation, mode of operation when defect was noted.

A warranty claim process will then begin. Vermont Castings, Majestic Products reserves the right to withhold final approval of a warranty claim pending a visual inspection of the defect by authorized representatives.

Please record the following information for future reference

Serial No. _____
Fuel Type: NG ____ LP ____
Manifold Pressure: _____
Inlet Supply Pressure: _____
Dealer _____

Phone _____
Date Purchased _____
Installer _____

Phone _____
Date Installed _____

CozyCabin.com 518-623-4349

Vermont Castings, Majestic Products
A Division of CFM Majestic Inc.

410 Admiral Blvd. • Mississauga, Ontario, Canada L5T 2N6 • 905-670-7885
www.cfmajestic.com • www.vermontcastings.com