

INSTALLER: THESE INSTRUCTIONS MUST BE CONVEYED TO AND REMAIN WITH THE HOMEOWNER.

CERTIFIED UNDER CANADIAN AND AMERICAN NATIONAL STANDARDS,
CSA 2.33 AND ANSI Z21.88 RESPECTIVELY FOR GAS-FIRED VENTED GAS FIRED SPACE HEATING APPLIANCE



FIREPLACES

GAS-FIRED WALL FURNACE
DIRECT VENT MILLIVOLT SYSTEM

INSTALLATION AND OPERATION INSTRUCTIONS FOR:

NATURAL GAS MODEL *GD3200-N / GD3200B-N*

PROPANE GAS MODEL *GD3200-P / GD3200B-P*

CERTIFIED FOR CANADA AND UNITED STATES USING ANSI / AGA / CGA METHODS

WARNING: If the information in these instructions is not followed exactly, a fire or explosion may result causing property damage, personal injury or death.

FOR YOUR SAFETY

Do not store or use gasoline or other flammable vapours and liquids in the vicinity of this or any other appliance.

WHAT TO DO IF YOU SMELL GAS:

- Do not try to light any appliance.
- Do not touch any electrical switch.
- Do not use any phone in your building.
- Immediately call your gas supplier from a neighbor's phone. Follow the gas supplier's instructions.
- If you cannot reach your gas supplier, call the fire department.

Installation and service must be performed by a qualified installer, service agency or the gas supplier.

**Wolf Steel Ltd., RR#1, 9 Napoleon Rd.,
Barrie, ON., Canada L4M 4Y8 (705)721-1212**

Fax: (705)722-6031 Email: ask@napoleon.on.ca
Web: www.napoleon.on.ca





TABLE of CONTENTS

PG 2-5	INTRODUCTION Warranty General Instructions General Information Care of Glass & Plated Parts	PG 16	OPTIONAL BLOWER INSTALLATION
5-7	VENTING Vent lengths Special Installation Example Air Terminal Locations	17	OPTIONAL FAN & THERMOSTATIC SENSOR
8-13	INSTALLATION / FRAMING Wall & Ceiling Protection Using Flexible Vent Components Fireplace Vent Connection Using Rigid Vent Components Gas Installation Mobile Home Installation Framing	18-19	OPERATION / MAINTENANCE Operating Instructions Maintenance
14-15	FINISHING Log Placement/Charcoal Embers Door, Louvre & Trim Installation	19	ADJUSTMENTS Pilot Burner Adjustment Venturi Adjustment
		20-21	REPLACEMENTS Ordering Replacement Parts Replacement Parts Accessories Vent Kits Terminal Kits
		22-23	TROUBLE SHOOTING GUIDE

PLEASE RETAIN THIS MANUAL FOR FUTURE REFERENCE

NAPOLEON gas fireplaces are manufactured under the strict Standard of the world recognized ISO9002 Quality Assurance Certificate.

NAPOLEON products are designed with superior components and materials, assembled by trained craftsmen who take great pride in their work. The burner and valve assembly are leak and test-fired at a quality test station. The complete fireplace is again test-fired and thoroughly inspected by a qualified technician before packaging to ensure that you, the customer, receives the quality product that you expect from NAPOLEON.

NAPOLEON GAS FIREPLACE PRESIDENT'S LIFETIME LIMITED WARRANTY

The following materials and workmanship in your new NAPOLEON gas fireplace are warranted against defects for as long as you own the fireplace. This covers: combustion chamber, heat exchanger, stainless steel burner, phazer™ logs and embers, ceramic glass (thermal breakage only), gold plated parts against tarnishing, porcelainized enamelled components and aluminum extrusion trims.

Electrical (110V and millivolt) components and wearable parts such as blowers, gas valves, thermal switch, switches, wiring, remote controls, ignitor, gasketing, and pilot assembly are covered and NAPOLEON will provide replacement parts free of charge during the first year of the limited warranty.

Labour related to warranty repair is covered free of charge during the first year. Repair work, however, requires the prior approval of an authorized company official. Labour costs to the account of NAPOLEON are based on a predetermined rate schedule and any repair work must be done through an authorized NAPOLEON dealer.

CONDITIONS AND LIMITATIONS

NAPOLEON warrants its products against manufacturing defects to the original purchaser only -- i.e., the individual or legal entity (registered customer) whose name appears on the warranty registration card filed with NAPOLEON -- provided that the purchase was made through an authorized NAPOLEON dealer and is subject to the following conditions and limitations:

This factory warranty is nontransferable and may not be extended whatsoever by any of our representatives.

The gas fireplace must be installed by a licenced, authorized service technician or contractor. Installation must be done in accordance with the installation instructions included with the product and all local and national building and fire codes.

This limited warranty does not cover damages caused by misuse, lack of maintenance, accident, alterations, abuse or neglect and parts installed from other manufacturers will nullify this warranty.

This limited warranty further does not cover any scratches, dents, corrosion or discolouring caused by excessive heat, abrasive and chemical cleaners nor chipping on porcelain enamel parts, mechanical breakage of PHAZER™ logs and embers, nor any venting components used in the installation of the fireplace.

NAPOLEON warrants its stainless steel burners against defects in workmanship and material for life, subject to the following conditions: During the first 10 years NAPOLEON will replace or repair the defective parts at our option free of charge. From 10 years to life, NAPOLEON will provide replacement burners at 50% of the current retail price.

In the first year only, this warranty extends to the repair or replacement of warranted parts which are defective in material or workmanship provided that the product has been operated in accordance with the operation instructions and under normal conditions.

After the first year, with respect to this President's Limited Lifetime Warranty, NAPOLEON may, at its discretion, fully discharge all obligations with respect to this warranty by refunding to the original warranted purchaser the wholesale price of any warranted but defective part(s).

After the first year, NAPOLEON will not be responsible for installation, labour or any other costs or expenses related to the reinstallation of a warranted part, and such expenses are not covered by this warranty.

Notwithstanding any provisions contained in this President's Limited Lifetime Warranty, NAPOLEON'S responsibility under this warranty is defined as above and it shall not in any event extend to any incidental, consequential or indirect damages.

This warranty defines the obligations and liability of NAPOLEON with respect to the NAPOLEON gas fireplace and any other warranties expressed or implied with respect to this product, its components or accessories are excluded.

NAPOLEON neither assumes, nor authorizes any third party to assume, on its behalf, any other liabilities with respect to the sale of this product. NAPOLEON will not be responsible for: over-firing, downdrafts, spillage caused by environmental conditions such as rooftops, buildings, nearby trees, hills, mountains, inadequate vents or ventilation, excessive venting configurations, insufficient makeup air, or negative air pressures which may or may not be caused by mechanical systems such as exhaust fans, furnaces, clothes dryers, etc.

Any damages to fireplace, combustion chamber, heat exchanger, brass trim or other component due to water, weather damage, long periods of dampness, condensation, damaging chemicals or cleaners will not be the responsibility of NAPOLEON.

The bill of sale or copy will be required together with a serial number and a model number when making any warranty claims from your authorized dealer. The warranty registration card must be returned within fourteen days to register the warranty.

NAPOLEON reserves the right to have its representative inspect any product or part thereof prior to honouring any warranty claim.

4 GENERAL INSTRUCTIONS

THIS GAS FIREPLACE SHOULD BE INSTALLED AND SERVICED BY A QUALIFIED INSTALLER to conform with local codes. In absence of local codes, install to the current CAN/CGA -B149 Installation Code in Canada or to the National Fuel Gas Code, ANSI Z223.1-1988, and NFPA 54-1988 in the United States. Suitable for mobile home installation if installed in accordance with the current standard CAN/CSA Z240MH Series, for gas equipped mobile homes, in Canada or ANSI Z223.1-1988 and NFPA 54-1988 in the United States.

PURGE ALL GAS LINES WITH THE GLASS DOOR OF THE FIREPLACE REMOVED. ASSURE THAT A CONTINUOUS GAS FLOW IS AT THE BURNER BEFORE INSTALLING THE DOOR.

UNDER EXTREME VENT CONFIGURATIONS, ALLOW SEVERAL MINUTES (5-15) FOR THE FLAME TO STABILIZE AFTER IGNITION.

ALL HORIZONTAL RUNS MUST HAVE A MINIMUM 1/4 INCH RISE PER FOOT. EIGHT (8") INCHES IS THE MINIMUM BEND RADIUS ALLOWED FOR THE 7" DIAMETER FLEXIBLE AIR LINER.

The fireplace and its individual shutoff valve must be disconnected from the gas supply piping system during any pressure testing of that system at test pressures in excess of 1/2 psig (3.5 kPa). The fireplace must be isolated from the gas supply piping system by closing its individual manual shutoff valve during any pressure testing of the gas supply piping system at test pressures equal to or less than 1/2 psig (3.5 kPa).

A 1/8 inch NPT plug, accessible for test gauge connection, must be installed immediately upstream of the gas supply connection to the fireplace.

When the fireplace is installed directly on carpeting, vinyl tile or other combustible material other than wood flooring, the fireplace shall be installed on a metal or wood panel extending the full width and depth.

The optional heat circulating blower is not supplied with a cord. If installed, the blower must be electrically connected and grounded in accordance with local codes. In the absence of local codes, use the current CSA C22.1 CANADIAN ELECTRICAL CODE in Canada or the ANSI/NFPA 70-1996 NATIONAL ELECTRICAL CODE in the United States.

WARNING

- Do not burn wood or other materials in this fireplace.
- Adults and especially children should be alerted to the hazards of high surface temperatures and should stay away to avoid burns or clothing ignition. Supervise young children when they are in the same room as the fireplace.
- Due to high temperatures, the fireplace should be located out of traffic and away from furniture and draperies.
- Clothing or other flammable material should not be placed on or near the fireplace.
- Any safety screen or guard removed for servicing must be replaced prior to operating the fireplace.
- It is imperative that the control compartments, burners and circulating blower and its passageway in the fireplace and venting system are kept clean. The fireplace and its venting system should be inspected before use and at least annually by a qualified service person. More frequent cleaning may be required due to excessive lint from carpeting, bedding material, etc. The fireplace area must be kept clear and free from combustible materials, gasoline and other flammable vapours and liquids.
- Under no circumstances should this fireplace be modified.
- This fireplace must not be connected to a chimney flue pipe serving a separate solid fuel burning appliance.
- Do not use this fireplace if any part has been under water. Immediately call a qualified service technician to inspect the fireplace and to replace any part of the control system and any gas control which has been under water.
- Do not operate the fireplace with the glass door removed, cracked or broken. Replacement of the glass should be done by a licensed or qualified service person.
- Do not strike or slam shut the fireplace glass door.

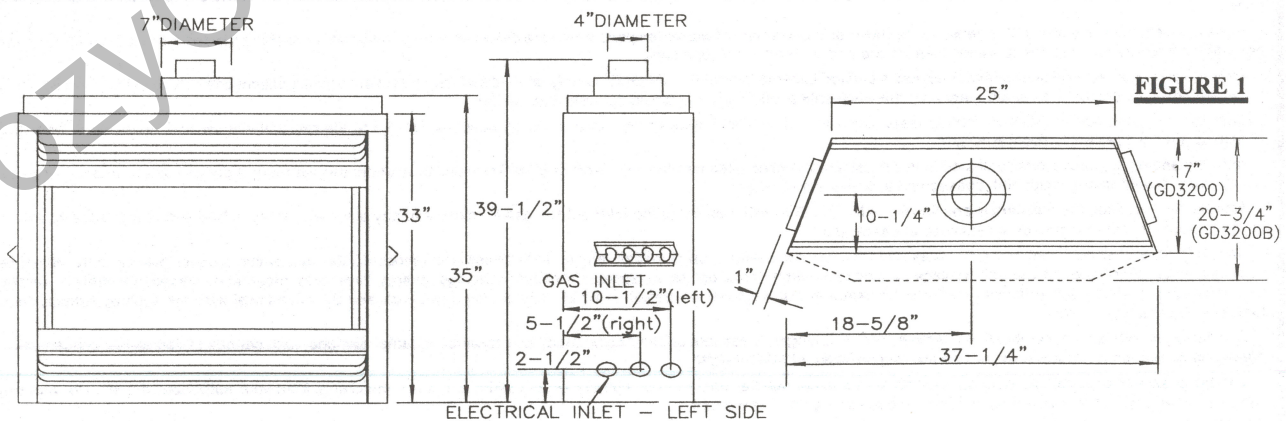

Provide adequate ventilation and combustion air. Provide adequate accessibility clearance for servicing and operating the fireplace. Never obstruct the front opening of the fireplace.

Minimum clearance to combustible construction from fireplace and vent surfaces:	sides, back, bottom, and top	0 inches
	vent pipe	1 inch
	recessed depth	17 inches

GENERAL INFORMATION

FOR YOUR SATISFACTION, THIS FIREPLACE HAS BEEN TEST-FIRED TO ASSURE ITS OPERATION AND QUALITY! Maximum input is 30,000 BTU/hr for natural gas and 24,000BTU/h for propane. When the fireplace is installed at elevations above 4,500ft, and in the absense of specific recommendations from the local authority having jurisdiction, the certified high altitude input rating shall be reduced at the rate of 4% for each additional 1,000ft. Maximum output for natural gas is 23,700 BTU/hr at an efficiency of 79% with the fan on, 78% with the fan off; and 19,200 BTU/hr for propane at an efficiency of 80% with the fan on, 79% with the fan off. Maximum A.F.U.E. (Annual Fuel Utilization Efficiency) rating is 71%. Minimum A.F.U.E. rating is 64%.

Minimum inlet gas supply pressure is 4.5 inches water column for natural gas and 11 inches water column for propane. Maximum inlet gas pressure is 7 inches water column for natural gas and 13 inches water column for propane. Manifold pressure under flow conditions is 3.5 inches water column for natural gas and 10 inches water column for propane. This fireplace is approved for bathroom, bedroom and bed-sitting room installations and is suitable for mobile home installation. The natural gas model can only be installed in a mobile home that is permanently positioned on its site and fueled with natural gas.

This fireplace may be installed in an aftermarket permanently located, manufactured (mobile) home, where not prohibited by local codes.

This fireplace is only for use with the type of gas indicated on the rating plate. This fireplace is not convertible for use with other gases, unless a certified kit is used.

NO EXTERNAL ELECTRICITY (110 VOLTS OR 24 VOLTS) IS REQUIRED FOR THE GAS SYSTEM OPERATION. Expansion / contraction noises during heating up and cooling down cycles are normal and are to be expected. Change in flame appearance from "HI" to "LO" is more evident in natural gas than in propane.

CARE OF GLASS, AND PLATED PARTS

Do not use abrasive cleaners to clean plated parts. Buff lightly with a clean dry cloth. The glass is 3/16" ceramic glass available from your Napoleon / Wolf Steel Ltd. dealer. **DO NOT SUBSTITUTE MATERIALS.** If the door glass should crack or break, do not operate the fireplace. Replace only with a door assembly certified with the fireplace. See **PAGE 11** for removal and replacement details. Clean the glass after the first 10 hours of operation with a recommended gas fireplace glass cleaner. Thereafter clean as required. **DO NOT CLEAN GLASS WHEN HOT!** If the glass is not kept clean permanent discoloration and / or blemishes may result.

VENTING

VENTING LENGTHS AND AIR TERMINAL LOCATIONS

ALL HORIZONTAL RUNS MUST HAVE A MINIMUM 1/4 INCH RISE PER FOOT IN ALL CASES. PROVIDE A MEANS FOR VISUALLY CHECKING THE VENT CONNECTION TO THE FIREPLACE AFTER THE FIREPLACE IS INSTALLED.

DO NOT ALLOW THE INSIDE LINER TO BUNCH UP ON HORIZONTAL OR VERTICAL RUNS AND ELBOWS. KEEP IT PULLED TIGHT. A 1/4" AIR GAP BETWEEN THE INNER AND OUTER LINER ALL AROUND IS REQUIRED FOR SAFE OPERATION.

VENT LENGTHS THAT PASS THROUGH UNHEATED SPACES (ATTICS, GARAGES, CRAWL SPACE) SHOULD BE WRAPPED WITH A PROTECTIVE INSULATION SLEEVE TO MINIMIZE CONDENSATION. USE A FIRESTOP WHEN PENETRATING INTERIOR WALLS, FLOOR OR CEILING.

Roof terminal kits are available for various vertical roof vent installations. Order the specific kit required from your Napoleon / Wolf Steel dealer. For horizontal installation, use the terminal (GD222) or the periscope (GD201) for below grade wall penetration. In conjunction with the various terminations, use the 5 foot vent kit (GD220) or the 10 foot vent kit (GD330).

For optimum flame appearance and fireplace performance, keep the vent length and number of elbows to a minimum. The maximum number of vent connections is two horizontally or three vertically (excluding the fireplace and the air terminal connections). The air terminal must remain unobstructed at all times. Examine the air terminal at least once a year to verify that it is unobstructed and undamaged.

*When venting, the horizontal run must be kept to a minimum of 11 inches or a maximum of 20 feet. If a 20 foot horizontal run is required, the fireplace must have a minimum vertical rise immediately off the fireplace of 57 inches. FIGURES 3a-c. When terminating vertically, the vertical rise is a minimum 34 inches and a maximum 40 feet above the fireplace. FIGURE 2. **This fireplace must be installed against a finished wall. Do not install against a vapour barrier or exposed insulation.***

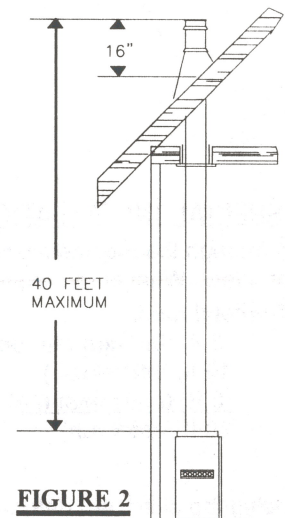
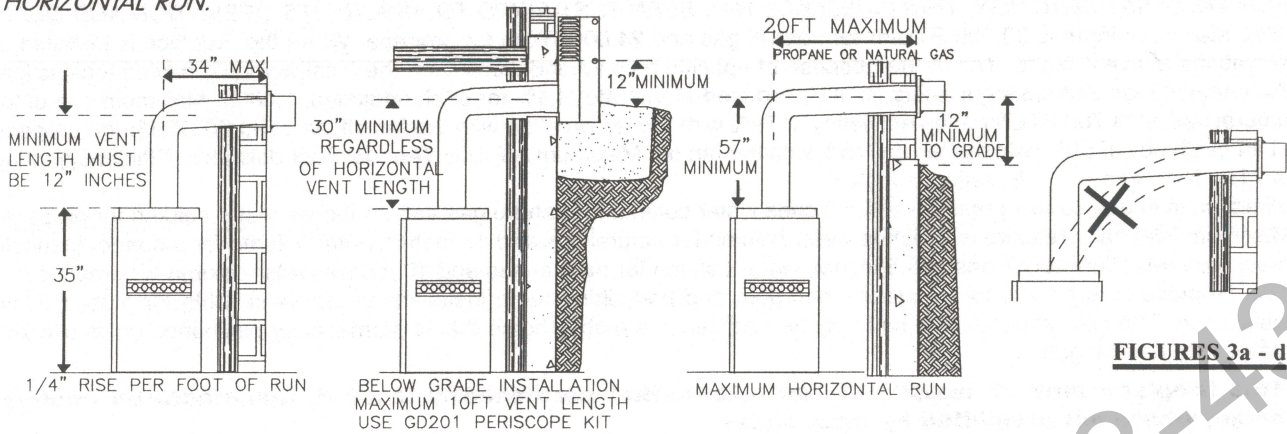

FIGURE 2

FOR SAFE AND PROPER OPERATION OF THE FIREPLACE FOLLOW THE VENTING INSTRUCTION EXACTLY.

DEVIATION FROM THE MINIMUM VERTICAL VENT LENGTH CAN CREATE DIFFICULTY IN BURNER START-UP AND/OR CARBONING. IF VERTICAL RISES GREATER THAN 57 INCHES ARE NECESSARY, THE INCREASED RISE MUST BE DEDUCTED FROM THE HORIZONTAL RUN.



Use the chart on this page to calculate horizontal runs for vertical rises between 12 and 57 inches. **FIGURE 4.** When calculating maximum run lengths, include 10 feet for each 90° elbow or 5 feet for each 45° elbow. (DO NOT INCLUDE THE FIRST ELBOW DIRECTLY OFF THE UNIT.)

FIGURE 4

REQUIRED VERTICAL RISE FROM FIREPLACE TO FIRST ELBOW IN INCHES

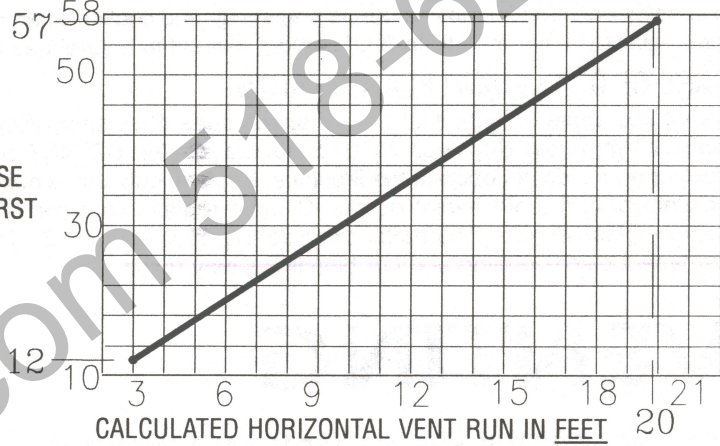

SPECIAL INSTALLATION EXAMPLE

A through the roof installation requires a total 5 foot rise. **FIGURE 5.** The location of the fireplace dictates a horizontal run of 5 feet. What is the required vertical rise to the centre of the initial 90° elbow?

The total run is:

- 5 ft. (through the roof vertical rise)
- 10 ft. (90° elbow)
- 5 ft. (horizontal run)
- 20 ft. (total run)

Using the chart, will determine that a 57 inch minimum vertical rise immediately off the unit is required for satisfactory venting conditions.

ALTHOUGH THE IMMEDIATE VERTICAL RUN MAY BE GREATER THAN 57 INCHES, THE MAXIMUM COMBINATION OF HORIZONTAL AND VERTICAL RUNS, BEYOND THE 57 INCHES, *MUST NOT EXCEED 20 FEET.*

Only the following Napoleon Vent Kits, used in combination with each other can be used:

- GD201, GD222, GD110, GD111 or GD112 (Periscope, Wall or Roof Terminals)
- and
- GD220 (5ft vent kit) or/and GD330 (10ft vent kits)

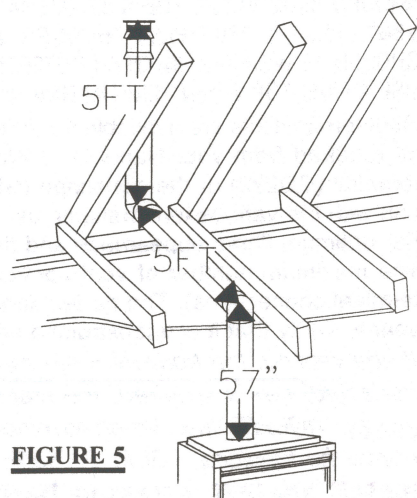

FIGURE 5

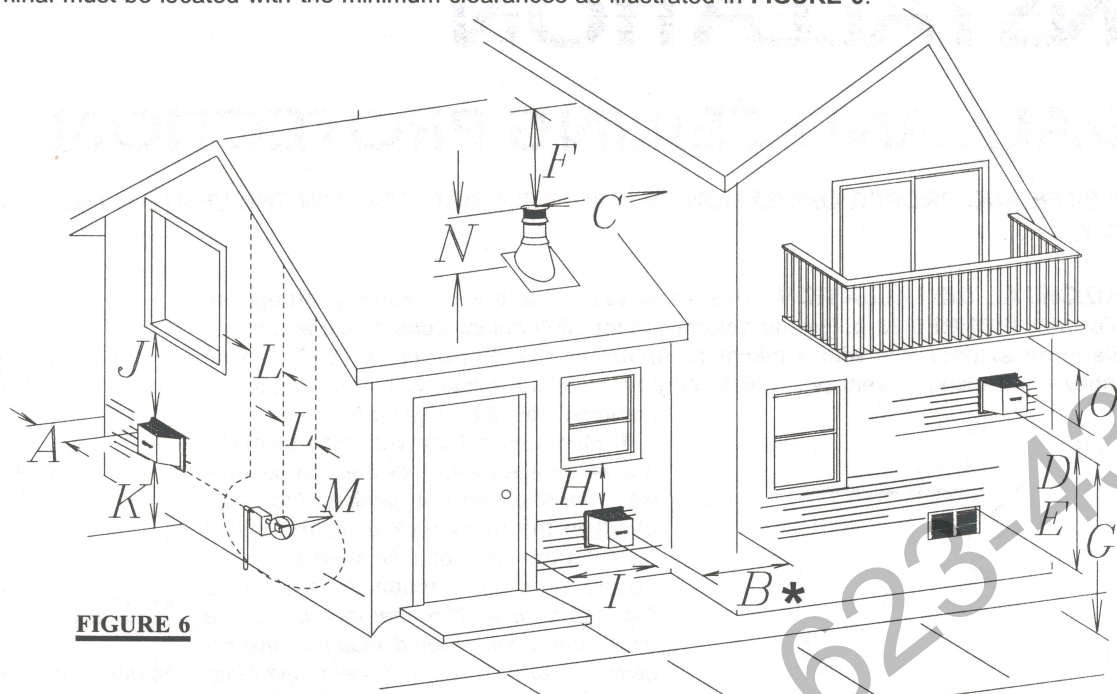

FIGURE 6

(A) **Flush (0 inches)** with outside non-combustible corner walls.

Two inches from outside combustible corner walls.

(B) **Flush (0 inches)** with inside corner walls or protruding non-combustible obstructions (chimney, etc)

Two inches from inside corner walls or protruding combustible obstructions (vent chase, etc)

* The periscope requires a minimum 18" clearance from an inside corner.

(C) **Two feet** from adjacent walls, including neighbouring buildings.

(D) **One foot** from the sides, top and bottom of a non-mechanical combustion or ventilation air supply.

(E) **Six feet** from mechanical combustion or ventilation air supplies.

(F) **One foot** to an unventilated soffit located above the terminal or **eighteen inches** to a ventilated soffit located above the terminal, provided the soffit is sealed for a distance of 24 inches either side of the centre line of the terminal.

(G) **Seven feet** above public walkways unless fitted with heat shield kit GD301.

(H) **One foot** below windows that open.

(I) **One foot** from the side of doors and windows that open.

(J) **One foot** from permanently closed windows.

(K) **One foot** above grade.

(L) NOT above a regulator/meter assembly or within **three feet** horizontally from the vertical centre-line of the assembly.

(M) **Six feet** from a gas service regulator vent outlet.

(N) **Sixteen inches** above the roof.

(O) **One foot** to the underside of a veranda, porch, deck or balcony that has a minimum of two open sides.

On all horizontal runs, when determining air terminal locations, check for appropriate rise per foot requirements.

A terminal shall not terminate directly above a sidewalk or paved driveway which is located between two single family dwellings and serves both dwellings. Local codes or regulations may require different clearances.

Do not allow the inside liner to bunch up on horizontal or vertical runs and elbows. Keep it pulled tight. A 1¼" air gap all around between the inner liner and outer liner is required for safe operation. Use a firestop when penetrating interior walls, floor or ceiling.

8 INSTALLATION

WALL AND CEILING PROTECTION

FOR SAFE AND PROPER OPERATION OF THE FIREPLACE, FOLLOW THE VENTING INSTRUCTIONS EXACTLY.

HORIZONTAL INSTALLATION: This application occurs when venting through an exterior wall. **FIGURES 3a-d.** Having determined the air terminal location, cut and frame a hole in an exterior wall with a minimum square or round opening of 9½". (As an alternative to framing, a vent pipe shield may be installed, ensuring a 1" clearance to combustibles. **See Figure 8.**)

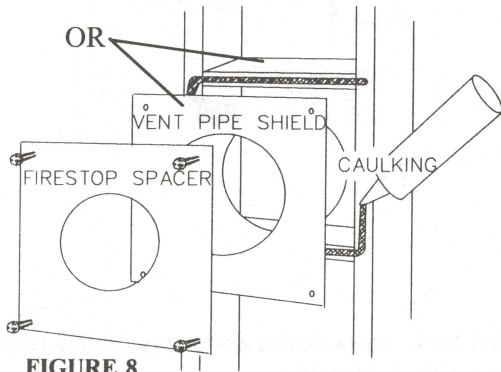

FIGURE 8

1. Mark and cut the vent pipe shield to the determined depth of the combustible wall. Apply a bead of caulking (not supplied) to the framework or to the shield plate (in the case of a finished wall) and secure the shield through the opening to the interior wall. *The final location of the vent pipe shield should maintain the required clearance to the 7" vent pipe / liner. Do not fill this cavity with any type of material.* Apply a bead of caulking all around and place a firestop spacer over the vent shield to restrict cold air from being drawn into the room or around the fireplace. Ensure

that both spacer and shield maintain the required clearance to combustibles. Once the vent pipe / liner is installed in its final position, apply sealant between the pipe / liner and the firestop spacer.

VERTICAL INSTALLATION: This application occurs when venting through a roof. **FIGURE 2.** Installation kits for various roof pitches are available from your Napoleon dealer. See Accessories to order the specific kit required.

1. Determine the air terminal location, cut and frame 9½ inch openings in the ceiling and the roof to provide the minimum 1 inch clearance between the fireplace pipe / liner and any combustible material. Try to center the exhaust pipe location midway between two joist to prevent having to cut them. Use a plumb bob to line up the center of the openings.

DO NOT FILL THIS SPACE WITH ANY TYPE OF MATERIAL.

A vent pipe shield will prevent any materials such as insulation, from filling up the 1" air space around the pipe. **FIGURE 11.** Nail headers between the joist for extra support.

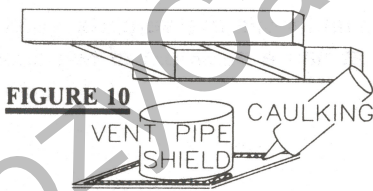

FIGURE 10

2. Apply a bead of caulking (not supplied) to the framework or to the Wolf Steel vent pipe shield plate or equivalent (in the case of a finished ceiling), and secure over the opening in the ceiling. **FIGURE 10.** A firestop must be placed on the bottom of each framed opening in a roof or ceiling that the venting system passes through. **FIGURE 11.** Apply a bead of caulking all around and place a firestop spacer over the vent shield to restrict cold air from being drawn into the room or around the fireplace. Ensure that both spacer and shield maintain the required clearance to combustibles. Once the vent pipe / liner

is installed in its final position, apply sealant between the pipe / liner and the firestop spacer.

3. In the attic, after the pipe / liner has been installed, slide the vent pipe collar down to cover up the open end of the shield and tighten. This will prevent any materials, such as insulation, from filling up the 1" air space around the pipe.

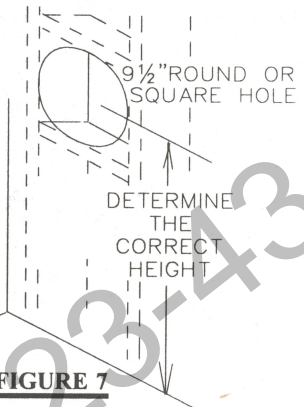

FIGURE 7

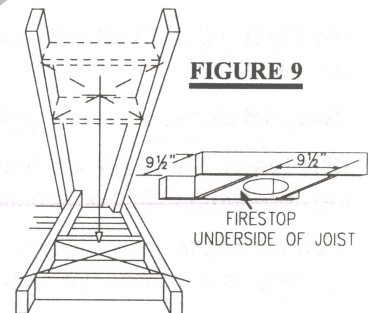

FIGURE 9

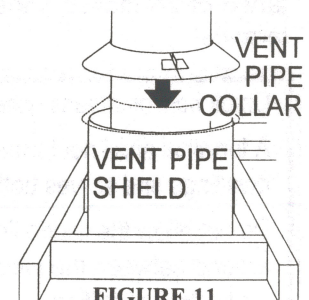

FIGURE 11

USING FLEXIBLE VENT COMPONENTS

ALL HORIZONTAL RUNS MUST HAVE A MINIMUM ¼ INCH RISE PER FOOT USING FLEXIBLE VENTING. FOR SAFE AND PROPER OPERATION OF THE FIREPLACE, FOLLOW THE VENTING INSTRUCTIONS EXACTLY.

HORIZONTAL AIR TERMINAL INSTALLATION

1. Stretch the 4" diameter aluminum flexible liner to the required length taking into account the additional length needed for the finished wall surface. Apply a heavy bead of the high temperature sealant, supplied with the unit, to the inside of the 4" liner approximately 1" from the end. Slip the liner a minimum of 2" over the fireplace vent collar and secure with 3 #8 screws.

2. Using the 7" diameter flexible aluminum liner, apply sealant, slide a minimum of 2" over the fireplace combustion air collar and secure with 3 #8 screws.

3. Insert the liners through the firestop. Position and secure the fireplace using the nailing tabs (2 per side) and/or secure to the floor using screws inserted through the two ¼" diameter holes in the front left and right corners of the base. The liners should be flush with the exterior wall. **The air terminal plate must not be recessed into the exterior wall or siding.**

4. From outside, apply a bead of the high temperature sealant to the inside of both liners, approximately 1" from the end of each liner.

5. Holding the air terminal (lettering in an upright, readable position), insert into both liners with a twisting motion to ensure that both the terminal sleeves engage into the liners / sealant. Secure the terminal to the exterior wall and make weather tight by sealing with caulking (not supplied).

6. If more liner needs to be used to reach the fireplace, couple them together as illustrated in **FIGURE 13**. The vent system must be supported approximately every 3 feet for both vertical and horizontal runs. Use Napoleon support ring assembly **GA-GD-010.370** or equivalent noncombustible strapping to maintain the minimum 1" clearance to combustibles.

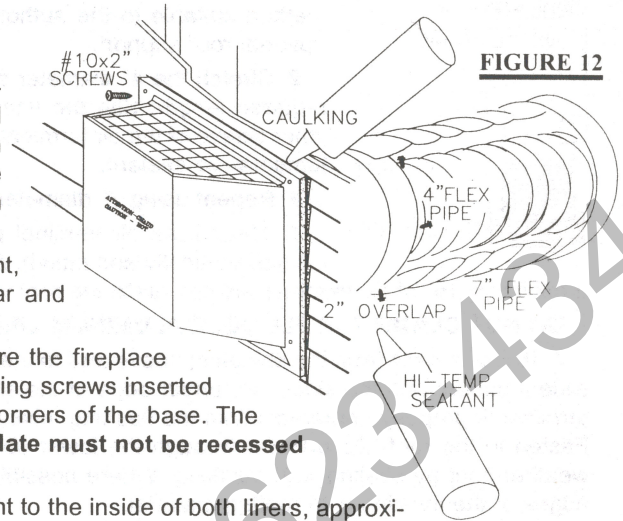

FIGURE 12

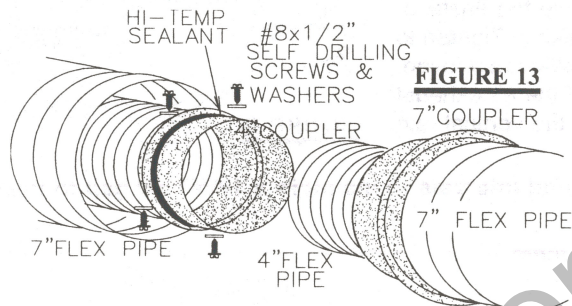
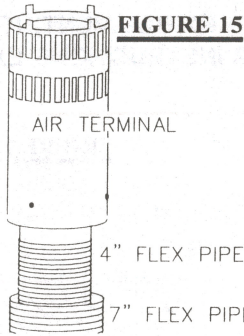

FIGURE 13

CozyCabin.com 234349

10 VERTICAL VENTING INSTALLATION



1. Fasten the roof support to the roof using the screws provided. The roof support is optional. In this case the venting is to be adequately supported using either an alternate method suitable to the authority having jurisdiction or the optional roof support.

2. Stretch the 4" diameter aluminum flexible liner to the required length. Slip the liner a minimum of 2" over the inner sleeve of the air terminal and secure with 3 #8 screws. Seal using a heavy bead of the high temperature sealant.

3. Repeat using 7" diameter aluminum flexible liner. **FIGURE 15.**

4. Thread the air terminal pipe assembly down through the roof. The air terminal must be located vertically and plumb. Attach the air terminal assembly to the roof support, ensuring that a minimum 16" of air terminal will penetrate the roof when fastened.

DO NOT CLAMP THE FLEXIBLE ALUMINUM LINER.

5. Remove nails from the shingles, above and to the sides of the chimney. Place the flashing over the air terminal and slide it underneath the sides and upper edge of the shingles. Ensure that the air terminal is properly centered within the flashing, giving a 3/4" margin all around. Fasten to the roof. Do not nail through the lower portion of the flashing. Make weather-tight by sealing with caulking. Where possible, cover the sides and top edges of the flashing with roofing material.

6. Apply a heavy bead of weatherproof caulking 2 inches above the flashing. Slide the storm collar around the air terminal and down to the caulking. Tighten to ensure that a weather-tight seal between the air terminal and the collar is achieved. Attach the other storm collar centered between the air intake and the air exhaust slots onto the air terminal. Tighten securely. **FIGURE 16.** Attach the vertical rain cap.

Spacers are attached to the 4" inner flex liner at predetermined intervals to maintain a 1-1/4" air gap to the 7" outer liner. These spacers must not be removed.

7. If more liner needs to be used to reach the fireplace, couple them together as illustrated in **FIGURE 13**. The vent system must be supported approximately every 3 feet for both vertical and horizontal runs. Use Wolf Steel support ring assembly **GA-GD-010.370** or equivalent noncombustible strapping to maintain a clearance to combustibles of 1".

FIREPLACE VENT CONNECTION

1. Install the 4 inch diameter aluminum flexible liner to the fireplace. Secure with 3 screws and flat washers. Seal the joint and screw holes using the high temperature sealant provided. **FIGURE 17.**

2. Install the 7 inch diameter aluminum flexible liner to the fireplace. Attach and seal the joints.

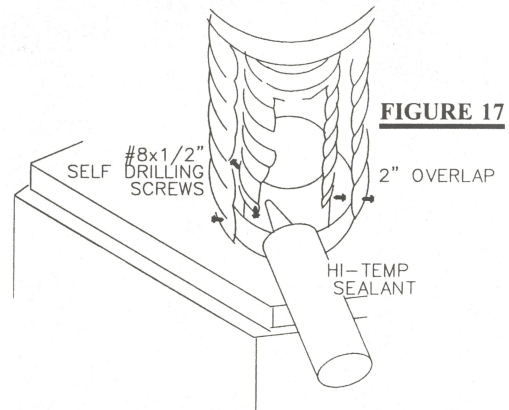
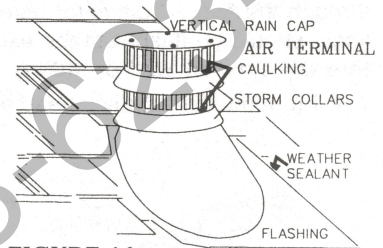
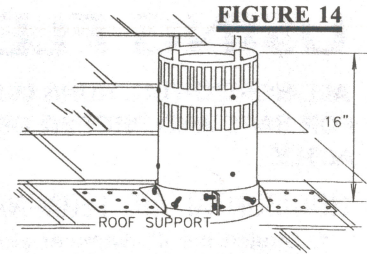

INSTALLATION

USING RIGID VENT COMPONENTS

FOR SAFE AND PROPER OPERATION OF THE FIREPLACE, FOLLOW THE VENTING INSTRUCTIONS EXACTLY.
HORIZONTAL RUNS MUST HAVE A ¼ INCH RISE PER FOOT

The vent system must be supported approximately every 3 feet for both vertical and horizontal runs. Use Napoleon vent spacers **WS-615-33** or equivalent every 3 feet and either side of each elbow to maintain the minimum 1¼" clearance between the outer and inner vent pipes. Use Napoleon support ring assembly **GA-GD-010.370** or equivalent noncombustible strapping to maintain the minimum 1" clearance to combustibles for both vertical and horizontal runs.

HORIZONTAL AIR TERMINAL INSTALLATION

1. Move the fireplace into position. Measure the vent length required between terminal and fireplace taking into account the additional length needed for the finished wall surface and any 1¼" overlaps between venting components.

2. Apply high temperature sealant to the outer edge of the 4" inner collar of the fireplace. Attach the first vent component and secure using 3 self tapping screws. Repeat using 7" piping.

3. Holding the air terminal (lettering in an upright, readable position), insert into both vent pipes with a twisting motion to ensure that both the terminal sleeves engage into the vent pipes and the sealant. Secure the terminal to the exterior wall and make weather tight by sealing with caulking (not supplied). **The air terminal plate must not be recessed into the exterior wall or siding.**

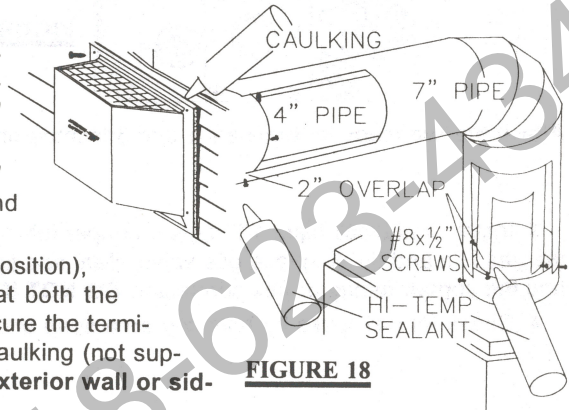

FIGURE 18

VERTICAL VENTING INSTALLATION

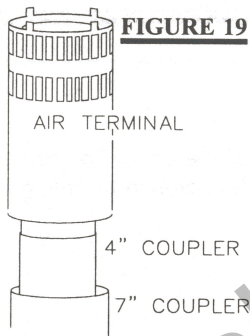

FIGURE 19

1. Move the fireplace into position.

2. Fasten the roof support to the roof using the screws provided. **FIGURE 14**. The roof support is optional. In this case the venting is to be adequately supported using either an alternate method suitable to the authority having jurisdiction or the optional roof support.

3. Apply high temperature sealant to the outer edge of the inner sleeve of the air terminal. Slip a 4" diameter coupler a minimum of 2" over the sleeve and secure using 3 screws.

4. Apply high temperature sealant to the outer edge of the of the outside sleeve of the air terminal. Slip a 7" diameter coupler over the sleeve and secure as before. **FIGURE 19**. Trim the 7" coupler even with the 4" coupler end.

5. Thread the air terminal pipe assembly down through the roof support and attach, ensuring that a minimum 16" of air terminal will penetrate the roof when fastened. **FIGURE 16**. **If the attic space is tight, we recommend threading the Wolf Steel vent pipe collar or equivalent**

loosely onto the air terminal assembly as it is passed through the attic. FIGURE 11. The air terminal must be located vertically and plumb.

6. Remove nails from the shingles, above and to the sides of the chimney. Place the flashing over the air terminal and slide it underneath the sides and upper edge of the shingles. Ensure that the air terminal is properly centered within the flashing, giving a 3/4" margin all around. Fasten to the roof. Do NOT nail through the lower portion of the flashing. Make weather-tight by sealing with caulking. Where possible, cover the sides and top edges of the flashing with roofing material.

7. Apply a heavy bead of waterproof caulking 2 inches above the flashing. Slide the storm collar around the air terminal and down to the caulking. Tighten to ensure that a weather-tight seal between the air terminal and the collar is achieved. Attach the other storm collar centered between the air intake and air exhaust slots onto the air terminal. Tighten securely. Attach the rain cap.

8. Continue adding rigid venting sections, sealing and securing as above. Attach a 4" collapsed telescopic pipe to the last section of rigid piping. Secure with screws and seal. Repeat using a 7" telescopic pipe.

9. Run a bead of high temperature sealant around the outside of the 4" elbow. Pull the adjustable pipe a minimum 2" onto the elbow. Secure with 3 screws. Repeat with the 7" telescopic pipe.

10. In the attic, slide the vent pipe collar down to cover up the open end of the shield and tighten. This will prevent any materials, such as insulation, from filling up the 1" air space around the pipe.

INSTALLATION / FRAMING

INSTALLATION

Proceed once the vent installation is complete.

1. Route a 3/8" N.P.T. black iron gas line, 1/2" type-L copper tubing or equivalent to the fireplace.
2. For ease of accessibility, an optional remote wall switch or millivolt thermostat may be installed in a convenient location. Route 2 strand (solid core) millivolt wire through the electrical hole located at the bottom left side of the unit. The recommended maximum lead length depends on wire size:

WIRE SIZE	MAX. LENGTH
14 gauge	100 feet
16 gauge	60 feet
18 gauge	40 feet

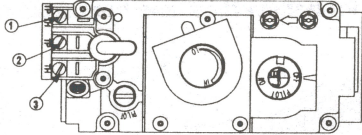

FIGURE 20

Attach the two leads to terminals 1 and 3 located on the gas valve.

DO NOT CONNECT EITHER THE WALL SWITCH, THERMOSTAT OR GAS VALVE TO ELECTRICITY (110 VOLTS).

3. Install rigid black pipe, 1/2" type-L copper tubing or, if local codes permit, a 3/8" flex connector and shutoff valve to the gas line and the fireplace gas valve. Seal and tighten securely. An adapter fitting is required between the gas valve and the copper tubing or flex connector. **DO NOT KINK THE FLEXIBLE CONNECTOR.**

4. Check for gas leaks by brushing on a soap and water solution. **DO NOT USE OPEN FLAME.**

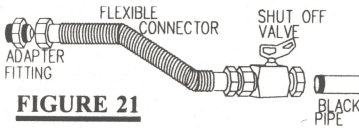

FIGURE 21

PURGE ALL GAS LINES WITH THE GLASS DOOR OF THE FIREPLACE REMOVED. ASSURE THAT A CONTINUOUS GAS FLOW IS AT THE BURNER BEFORE RE-INSTALLING THE DOOR.

MOBILE HOME INSTALLATION

The fireplace is equipped with two 1/4" diameter holes located in the front left and right corners of the base. For mobile home installations, the fireplace must be fastened in place. Use #10 screws, inserted through the holes in the base to secure. It is recommended that the fireplace be secured in all installations.

FRAMING

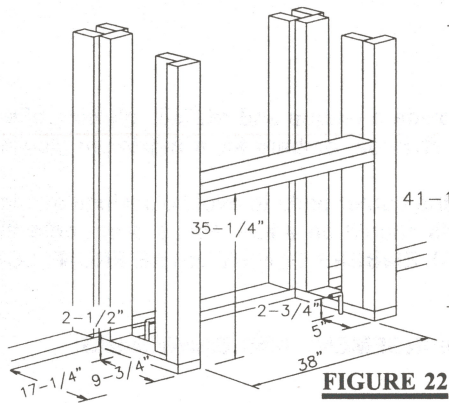

FIGURE 22

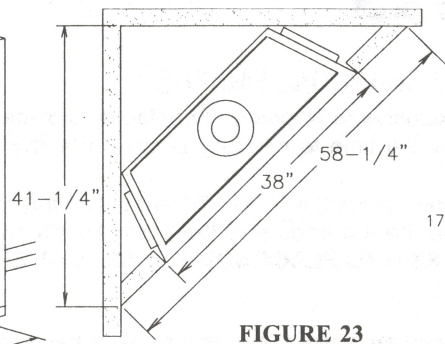

FIGURE 23

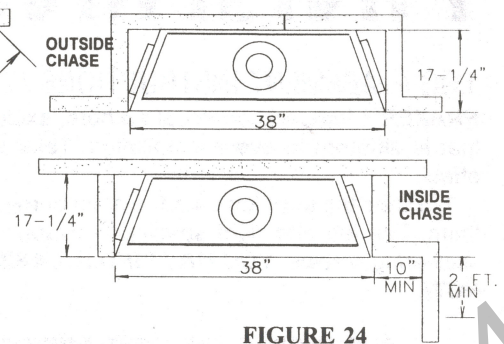

FIGURE 24

It is best to frame your fireplace after it is positioned and the vent system is installed. Use 2x4's and frame to local building codes. **FIGURE 22-24.** To install the fireplace face flush with the finished wall, position the framework to accommodate the thickness of the finished wall. Pull out the four nailing tabs, attached on either side of the fireplace and secure to the 2x4 framing to facilitate drywall installation.

Combustible materials may be installed flush with the front of the fireplace but must not cover any of the black face-areas of the fireplace. Non-combustible material (brick, stone or ceramic tile) may protrude in these areas.

It is not necessary to install a hearth extension with this fireplace system. Objects placed in front of the fireplace should be kept a minimum of 24" away from the front face.

Combustible mantle clearance can vary according to the mantle depth. **FIGURE 25.** Use the graph to help evaluate the clearance needed.

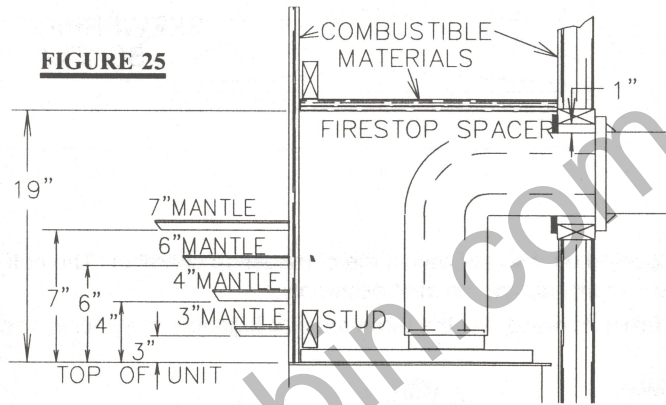

FIGURE 25

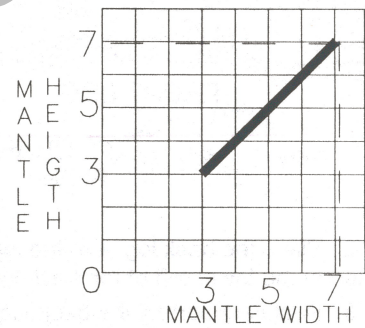

FIGURE 26

CozyCabin.com 518-623-4349

FINISHING

LOG PLACEMENT INSTRUCTIONS / CHARCOAL EMBERS

PHAZER™ logs and charcoal embers, exclusive to Napoleon Fireplaces, provide a unique and realistic glowing effect that is different in every installation. Take the time to carefully position the charcoal embers for a maximum glowing effect.

1. Place the front log onto the main burner, placing it $1/4"$ - $3/8"$ away from the burner ports to avoid blocking/covering them. The left and right spacing between the log ends and the burner ports should be equal. Press down onto the skewering screws. **YOU MAY FIND IT EASIER TO PLACE SOME CHARCOAL EMBERS BENEATH THE FRONT LOG NOW.**

POSITIONING THE LOGS IMPROPERLY WILL CAUSE FLAME IMPINGEMENT AND CARBONING.

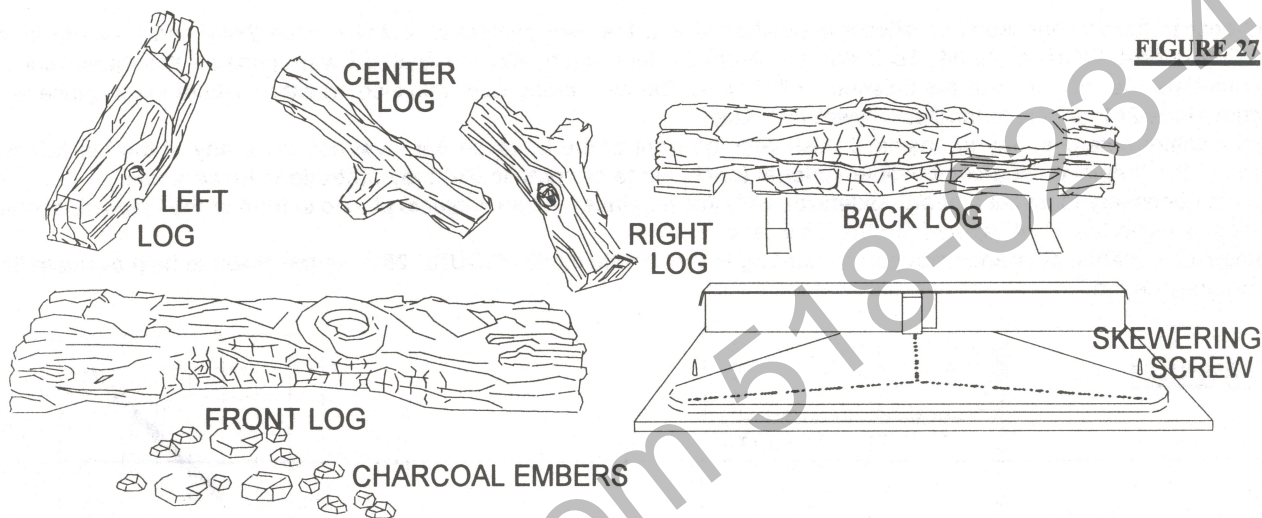

2. Place the back log onto the log support brackets located on the rear wall of the combustion chamber. The notch situated at the lower left of the back log should be centered evenly above the pilot assembly.

3. While supporting the back log, to prevent it from falling forward, set the three smaller logs into the pockets and grooves of the front and back logs, respectively.

Log colours may vary. During the initial use of the fireplace, the colours will become more uniform as colour pigments burn in during the heat activated curing process.

CHARCOAL EMBERS: Randomly place the embers beneath the front log, covering all of the burner area beneath the hollowed out section of the log. Place the remaining embers along the front. Keep ember dust away from burner ports to avoid plugging them.

Fine dust found in bottom of bag not to be used. PHAZER™ logs and charcoal embers glow when exposed to direct flame. Use only certified **PHAZER™** logs and charcoal embers available from your Napoleon / Wolf Steel Ltd. dealer.



DOOR, LOUVRE AND TRIM REMOVAL & INSTALLATION

ENSURE THAT THE DOOR IS PROPERLY CLIPPED ONTO THE STEEL LIP TO PREVENT OVERHEATING, GLASS BREAKAGE AND/OR DISCOLOURATION OF THE UPPER TRIM.

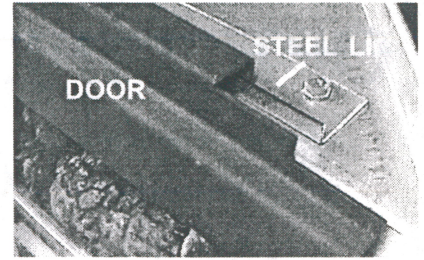

FIGURE 29

GD3200

DOOR REMOVAL: Both top and bottom door trim must be removed prior to door removal. Lift up the top trim and unhook from the door. The bottom trim may be pulled off and lifted out of the bottom door sill. **FIGURE 30.**

Remove the five screws securing the sides and bottom of the door. Lift up and out.

DOOR AND TRIM INSTALLATION: When re-installing, retighten screws snugly. **DO NOT OVERTIGHTEN.**

Hang the door side trim onto each door side with the notches towards the centre of the unit. The top and bottom door trim may be installed next. Attach magnets to the top and bottom door trim approximately 4" from either end. Lift up the top trim and hook over the top of the door. The bottom trim is inserted into the bottom door sill. Push in to engage the magnets. Centre both side trims.

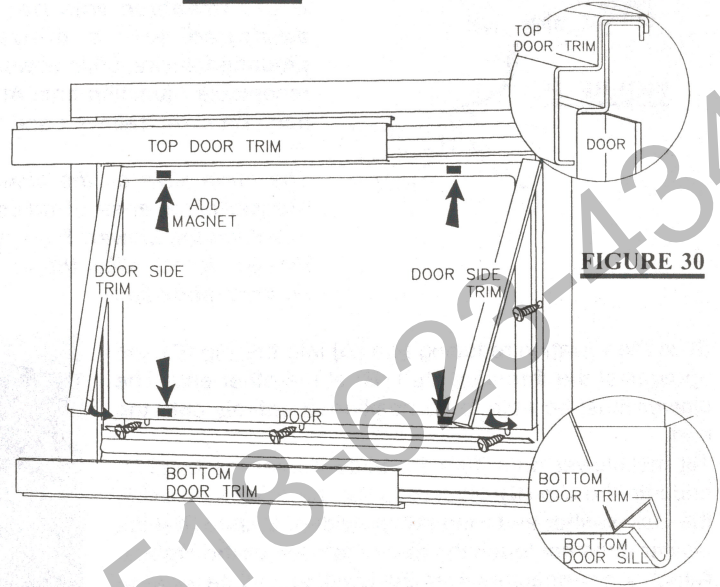
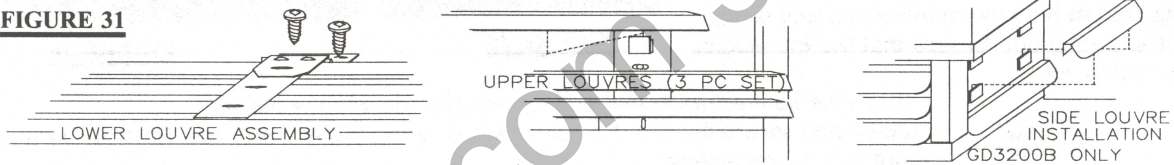

FIGURE 30

FIGURE 31



LOUVRES: The louvre assemblies are installed as illustrated in **FIGURE 31**. Optional arched door facias and black webbed facias are available at your local Napoleon/ Wolf Steel dealer.

GD3200B

DOOR REMOVAL: To access the firebox, remove the two screws securing the bay window facade assembly in place. Lift up and out. Remove the screws securing the sides and bottom of the door. Lift up and out. To re-install, repeat in reverse order. Retighten screws snugly. **DO NOT OVERTIGHTEN.**

TRIM: To install the hinge screen trim, remove the protective plastic wrap from the front of the trim. Attach the four magnets and push the trim onto the fireplace. **FIGURE 32.**

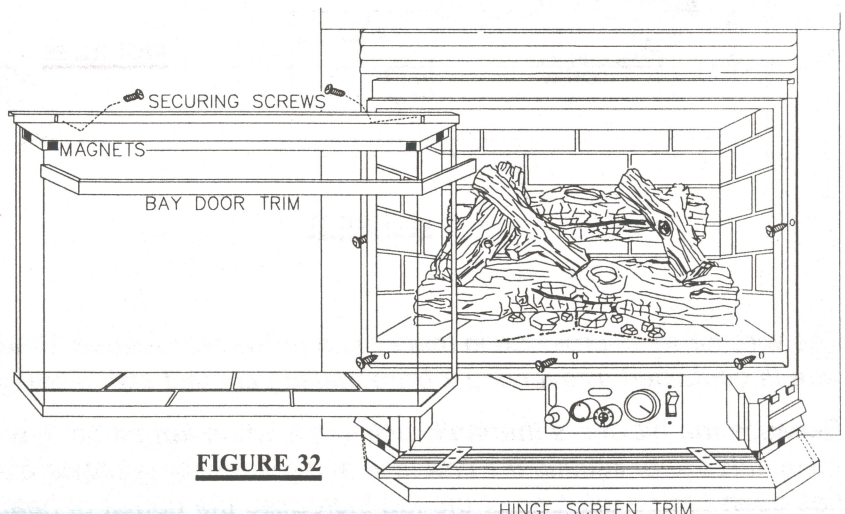

FIGURE 32

LOUVRES: Install the louvres and louvre assemblies as illustrated in **FIGURE 31**. The bay door trim is attached with magnets.

OPTIONAL BLOWER INSTALLATION

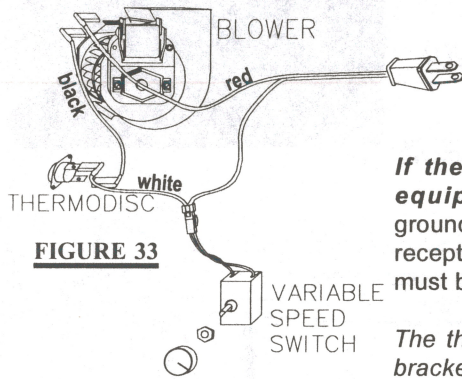

FIGURE 33

INSTALLATION TO BE DONE BY A QUALIFIED INSTALLER and must be electrically connected and grounded in accordance with local codes. In the absence of local codes, use the current CSA C22.1 CANADIAN ELECTRICAL CODE in Canada or the ANSI/NFPA 70-1996 NATIONAL ELECTRICAL CODE in the United States.

If the fireplace was not previously equipped with a blower: route a grounded 2-wire, 60hz power cable to the receptacle / junction box. At this point, it must be strain relieved and insulated.

The three slots on the blower mounting bracket allow ease of adjustment when attaching the blower. For a quiet running blower, do not allow the assembly to sit on the firebox base.

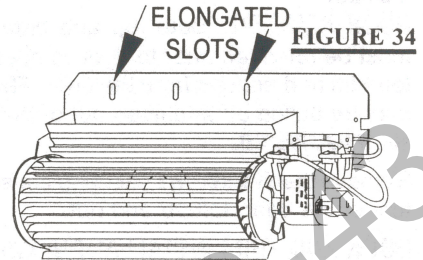

FIGURE 34

Slide the vibration reducing pad (A) into the clip (C) and up against the threaded stud (B) at the other end. The blower must be able to be positioned entirely onto the pad.

Tilt the blower onto its side. Slide it past the controls and into the clip (C). Secure to the threaded stud using the lock washer and wing nut provided. Ensure that the blower does not touch the fireplace base or the firebox. Attach the connectors from the black and white wires to the thermodisc and secure the thermodisc bracket to the securing stud at the bottom left of the unit using a lock washer and wing nut. Ensure that the thermodisc touches the firebox wall.

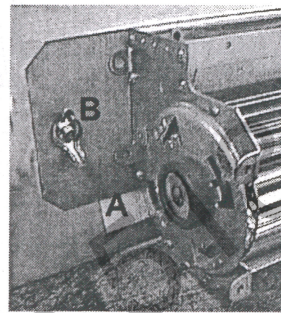

FIGURE 35

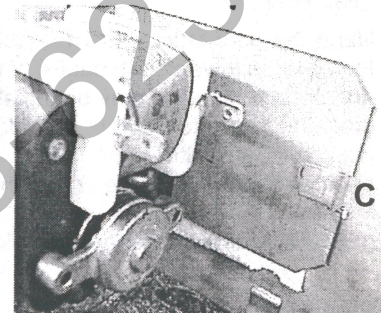

FIGURE 36

Attach the connectors from the black and red wires to the blower. Attach and secure the variable speed switch using the nut provided. Plug the harness cord into the receptacle.

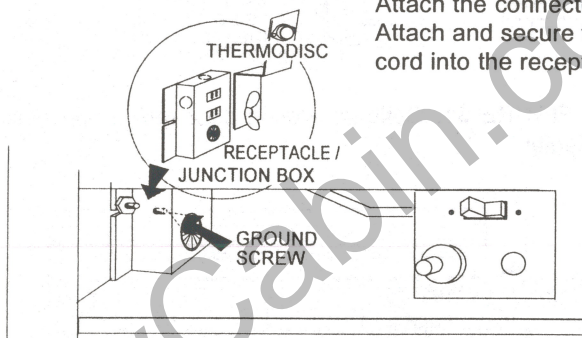

FIGURE 37

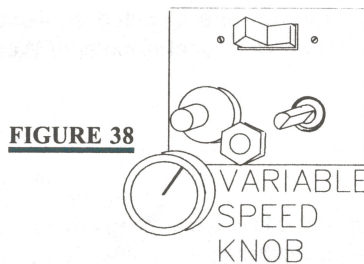

FIGURE 38

VARIABLE SPEED KNOB

The wire harness provided in this kit is a universal harness. When installed, ensure that any excess wire is contained, preventing it from making contact with moving or hot objects.

Because the blower is thermally activated, when turned on, it will automatically start approximately 10 minutes after lighting the fireplace and will run for approximately 30-45 minutes after the fireplace has been turned off. Use of the fan increases the output of heat.

OPTIONAL FAN INSTALLATION

ELECTRICAL INSTALLATION TO BE DONE BY A QUALIFIED INSTALLER and must be connected and grounded in accordance with local codes. In the absence of local codes, use the current CSA C22.1 CANADIAN ELECTRICAL CODE in Canada or the ANSI/NFPA 70-1990 NATIONAL ELECTRICAL CODE in the United States.

If the fireplace was not previously equipped with a fan: route a grounded 2-wire, 60hz power cable to the junction box. At this point, it must be strain relieved and insulated.

The wire harness provided in this kit is a universal harness. When installed, ensure that any excess wire is contained, preventing it from making contact with moving or hot objects.

Position the vibration reducing pad into the clip and onto the threaded stud at the other end, piercing a hole into the pad. The fan assembly must be able to be positioned entirely onto the pad. Slide the fan assembly past the controls and into the clip. Secure using the lock washer and nut provided. Attach the connectors from the black and white wires to the thermodisc and secure the thermodisc bracket to the securing stud at the bottom left of the unit using a lock washer and wing nut. Ensure that the thermodisc touches the firebox wall.

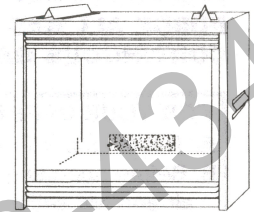

FIGURE 39

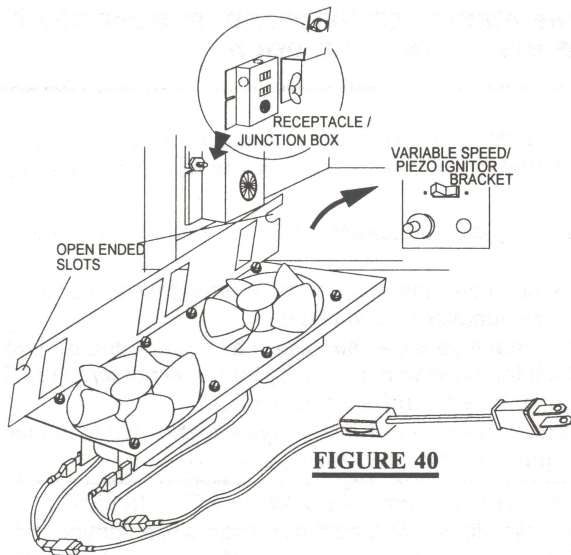

FIGURE 40

GD36 THERMOSTATIC SENSOR CONTROL

This optional kit is meant to be used only in conjunction with the GD65 Fan Kit, shown above, which may be ordered from your Wolf Steel / Napoleon dealer.

With the thermostatic sensor option, the fan, when turned on, becomes thermally activated, and will automatically run approximately 15-30 minutes after the fireplace has been lit and for approximately 30-45 minutes after the fireplace has been turned off.

Use of the fan increases the output of heat.

Unplug the power cord from the receptacle. Connect all wires as shown.

Attach and secure the sensor assembly bracket to the securing stud located next to the receptacle/junction box at the bottom left of the unit using the lock washer and wing nut. Ensure that the thermodisc touches the firebox wall.

Plug the power cord back into the receptacle.

When installed, ensure that any excess wire is contained, preventing it from making contact with moving or hot objects.

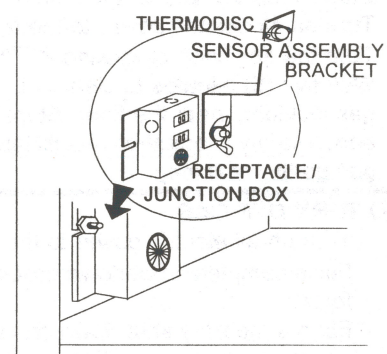

FIGURE 41

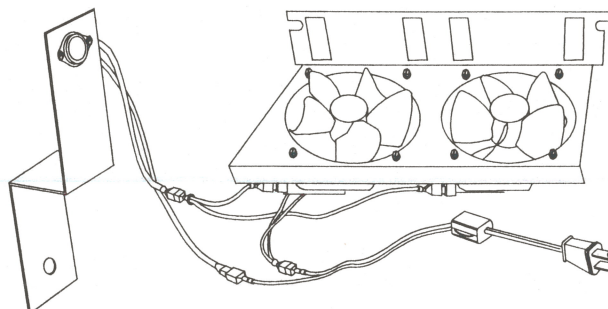

FIGURE 42

OPERATION / MAINTENANCE

OPERATING INSTRUCTIONS

When lit for the first time, the fireplace will emit a slight odour for a few hours. This is a normal temporary condition caused by the curing of the logs and the "burn-in" of internal paints and lubricants used in the manufacturing process and will not occur again. Simply open a window to sufficiently ventilate the room.

After extended periods of non-operation such as following a vacation or a warm weather season, the fireplace may emit a slight odour for a few hours. This is caused by dust particles in the heat exchanger burning off. Open a window to sufficiently ventilate the room.

PURGE ALL GAS LINES WITH THE GLASS DOOR OF THE FIREPLACE REMOVED. ASSURE THAT A CONTINUOUS GAS FLOW IS AT THE BURNER BEFORE INSTALLING THE DOOR.

FOR YOUR SAFETY READ BEFORE OPERATING

- A. This fireplace is equipped with a pilot which must be lit by hand while following these instructions exactly.
 B. Before operating smell all around the fireplace area for gas and next to the floor because some gas is heavier than air and will settle on the floor.

WHAT TO DO IF YOU SMELL GAS:

- Turn off all gas to the fireplace.
- Open windows.
- Do not try to light any appliance.



- Do not touch any electric switch; do not use any phone in your building.
- Immediately call your gas supplier from a neighbour's phone. Follow the gas supplier's instructions.
- If you cannot reach your gas supplier, call the fire department.

- C. Use only your hand to turn the gas control knob. Never use tools. If the knob will not turn by hand, do not try to repair it. Call a qualified service technician. Force or attempted repair may result in a fire or explosion.
 D. Do not use this fireplace if any part has been under water. Immediately call a qualified service technician to inspect the fireplace and replace any part of the control system and any gas control which has been under water.

LIGHTING INSTRUCTIONS

WARNING: The gas valve has an interlock device which will not allow the pilot burner to be lit until the thermocouple has cooled. Allow approximately 60 seconds for the thermocouple to cool.

When lighting and re-lighting, the gas knob cannot be turned from pilot to off unless the knob is **depressed slightly**.

1. Stop! Read the above safety information on this label.
2. Turn off all electric power to the fireplace.
3. Turn the gas knob clockwise to off.
4. Wait five (5) minutes to clear out any gas. If you smell gas including near the floor. Stop! Follow "B" in the above safety information on this label. If you don't smell gas go the next step.

5. Turn gas knob counter-clockwise to pilot.
6. Depress slightly and hold gas knob while lighting the pilot with the push button ignitor. Keep knob depressed for one minute, then release. If pilot does not continue to burn, repeat steps 3 through 5.
7. With pilot lit, depress and turn gas knob counter-clockwise to on.
8. If equipped with remote on-off switch/thermostat, main burner may not come on when you turn valve to on. Remote switch must be in the on position to ignite burner.
9. Turn on all electric power to the fireplace.

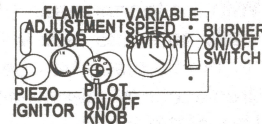

TO TURN OFF GAS

1. Turn off all electric power to the fireplace if service is to be performed.
2. For a complete shut-down procedure: push in gas control knob slightly and turn clockwise to off. Do not force.
3. For a temporary shut-down procedure: set thermostat to lowest setting or remote switch to off. Press and turn the gas knob clockwise to pilot.

MAINTENANCE TURN OFF THE GAS AND ELECTRICAL POWER BEFORE SERVICING THE FIREPLACE.

CAUTION: Label all wires prior to disconnection when servicing controls. Wiring errors can cause improper and dangerous operation. Verify proper operation after servicing. This fireplace and its venting system should be inspected before use and at least annually by a qualified service person. The fireplace area must be kept clear and free of combustible materials, gasoline or other flammable vapours and liquids. The flow of combustion and ventilation air must not be obstructed.

1. In order to properly clean the burner and pilot assembly, remove the logs to expose both assemblies.
2. Keep the control compartment, logs, burner, air shutter opening and the area surrounding the logs clean by vacuuming or brushing, *at least once a year*.
3. Check to see that all burner ports are burning. Clean out any of the ports which may not be burning or are not burning properly. (right brick panel must be removed in order to facilitate burner removal, where applicable.)
4. Check to see that the pilot flame is large enough to engulf the thermocouple and thermopile and reaches toward the burner with the third jet.
5. Replace the cleaned logs.
6. Check to see that the main burner ignites completely on all openings when the gas knob for the burner is turned on. A 5 to 10 second total light-up period is satisfactory. If ignition takes longer, consult your Napoleon dealer / distributor.
7. Check that the gasketing on the sides, top and bottom of the door is not broken or missing. Replace if necessary.

ADJUSTMENTS

PILOT BURNER ADJUSTMENT

Adjust the pilot screw to provide properly sized flame. Turn in a clockwise direction to reduce the gas flow. **FIGURES 43 & 44.**

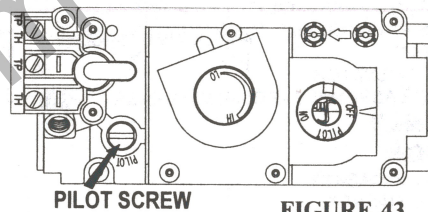
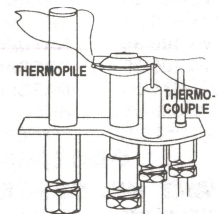

FIGURE 43



FLAME MUST ENVELOPE UPPER 3/8" TO 1/2" OF THERMOCOUPLE & THERMOPILE

FIGURE 44

VENTURI ADJUSTMENT

Natural gas models have air shutters set at 3/16 (.188") inch open. Propane gas models have air shutters set at 3/8 (.375) inch open. Closing the air shutter will cause a more yellow flame, but can lead to carboning. Opening the air shutter will cause a more blue flame, but can cause flame lifting from the burner ports. The flame may not appear yellow immediately; allow 15 to 30 minutes for the final flame colour to be established. **FIGURE 45.**

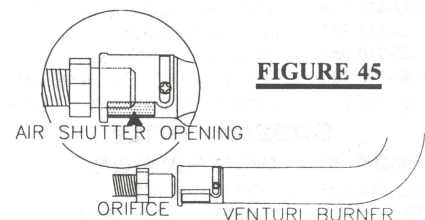

FIGURE 45

AIR SHUTTER ADJUSTMENT MUST ONLY BE DONE BY A QUALIFIED GAS INSTALLER!

REPLACEMENTS

ORDERING REPLACEMENT PARTS

Contact your dealer or the factory for questions concerning prices and policies on replacement parts. Normally all parts can be ordered through your Napoleon dealer or distributor. When ordering replacement parts always give the following information:

1. Model & Serial Number of the unit.
2. Installation date of the unit.
3. Part Number
4. Part Description
5. Finish

REPLACEMENT PARTS For warranty replacement parts, a photocopy of the original invoice will be required to honour the claim.

PART NO. DESCRIPTION

- GI-135.07 BACK LOG
- GI-135.052 FRONT LOG
- GI-135.15 RIGHT LOG
- GI-135.09 CENTER LOG
- GI-135.16 LEFT LOG
- GL-610 LOG SET ASSEMBLY c/w CHARCOAL EMBERS
- GI-550.01 CHARCOAL EMBERS
- GD-225.36 BLACK DOOR FRAME
- GD-321K BLACK DOOR c/w GLASS
- GD-010.454 GLASS c/w GASKET
- GD-562.09 DOOR GASKET (100 INCHES)
- GD-020.042 PKG OF 5 DOOR SCREWS
- GD-200.055 DOOR SIDE TRIM ea
- WS-430-001 CERAMIC MAGNET
- GD-10.352 BURNER ASSEMBLY
- WS-725-25 NATURAL GAS VALVE
- WS-725-26 PROPANE GAS VALVE
- WS-455-23 NATURAL GAS PILOT ORIFICE - #51
- WS-455-24 PROPANE GAS PILOT ORIFICE - #30
- WS-380-007 PILOT ON/OFF KNOB EXTENSION
- WS-380-006 FLAME ADJUSTMENT KNOB EXTENSION
- WS-573-008 HIGH TEMPERATURE SEALANT
- WS-455-04 #36 NATURAL GAS ORIFICE
- WS-455-03 #54 PROPANE GAS ORIFICE
- WS-357-01 PIEZO IGNITER
- WS-680-05 THERMOCOUPLE
- WS-680-04 THERMOPILE
- WS-100-38 NATURAL GAS PILOT ASSEMBLY
- WS-100-39 PROPANE GAS PILOT ASSEMBLY
- WS-385-33 NAPOLEON LOGO
- GD-660-05 BURNER ON/OFF SWITCH
- GD-010.391 LOWER LOUVRE ASSEMBLY - POLISHED BRASS

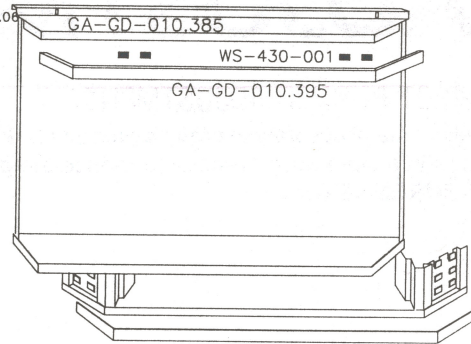
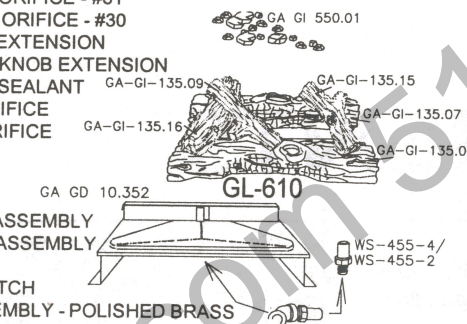
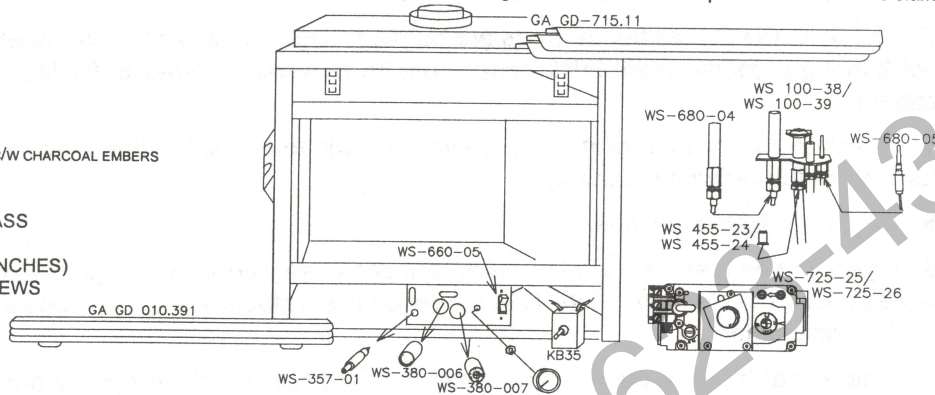

GD3200B - ONLY

PART NO. DESCRIPTION

- GD-010.383 FRONT GLASS c/w GASKET
- GD-010.384 SIDE GLASS c/w GASKET
- GD-010.385 BAY FRAME ASSEMBLY
- GD-010.395 BAY DOOR TRIM - POLISHED BRASS c/w MAGNETS
- GD-010.389 BOTTOM TRIM - POLISHED BRASS
- GD-475.149 REAR BRICK PANEL
- GD-475.153 FRONT BRICK PANEL
- GD-475.148 RIGHT SIDE BRICK PANEL
- GD-475.147 LEFT SIDE BRICK PANEL
- GD-010.388 LOWER LOUVRE ASSEMBLY - POLISHED BRASS
- GD-715.145 SIDE LOUVRE - POLISHED BRASS
- GD-715.11 UPPER LOUVRE - POLISHED BRASS

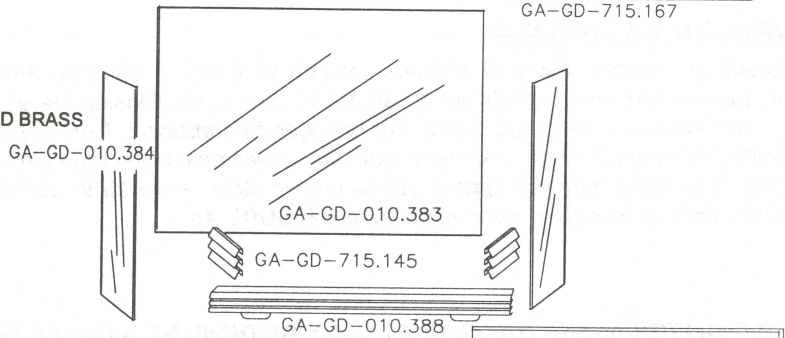

GD3200 - ONLY

PART NO. DESCRIPTION

- GD-715.136 TOP DOOR TRIM
- GD-715.137 BOTTOM DOOR TRIM

VENT KITS

GD220 (5 FOOT)

PART NO. DESCRIPTION

- GD-010.397 4" FLEXIBLE ALUMINUM LINER c/w SPACERS
- WS-410-17 7" FLEXIBLE ALUMINUM LINER

GD330 (10 FOOT)

PART NO. DESCRIPTION

- GS-10.300 4" FLEXIBLE ALUMINUM LINER c/w SPACERS
- WS-410-018 7" FLEXIBLE ALUMINUM LINER
- GD-010.370 WALL SUPPORT ASSEMBLY

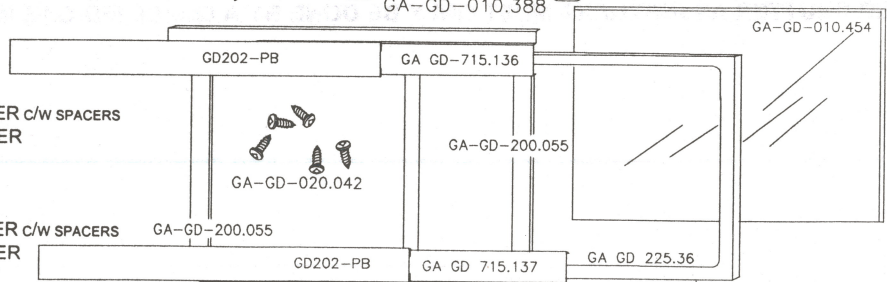

TERMINAL KITS

GD110 - ROOF TERMINAL KIT - 1/12 TO 7/12 PITCH

- GD-010.210 AIR TERMINAL
- GD-120.036 VERTICAL CAP
- GD-010.453 ROOF SUPPORT
- WS-170-052 STORM COLLAR
- WS-263-054 ROOF FLASHING

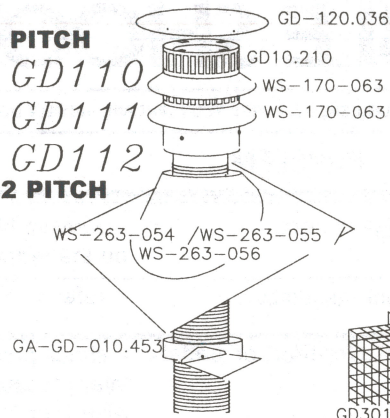

GD111 - ROOF TERMINAL KIT - 8/12 TO 12/12 PITCH

- GD-010.210 AIR TERMINAL
- GD-120.036 VERTICAL CAP
- GD-010.453 ROOF SUPPORT
- WS-170-052 STORM COLLAR
- WS-263-055 ROOF FLASHING

GD112 - ROOF TERMINAL KIT - FLAT ROOF

- GD-010.210 AIR TERMINAL
- GD-010.453 ROOF SUPPORT
- GD-120.036 VERTICAL CAP
- WS-263-056 ROOF FLASHING
- WS-170-063 STORM COLLAR

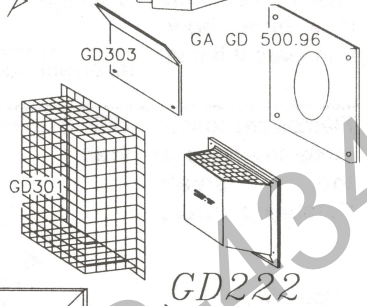
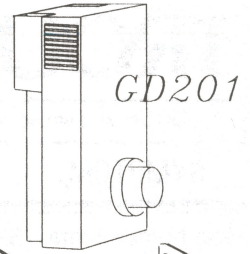

**PERISCOPE - GD201
WALL TERMINAL KIT - GD222**

ACCESSORIES

PART NO. DESCRIPTION

- GA-GD-500.96 FIRE STOP - FLEXIBLE VENTING
- GD-GD-500.136 FIRE STOP - RIGID VENTING
- WS-573-008 HI-TEMP SEALANT
- GD101 WINDSHIELD KIT
- GD301 HEAT GUARD
- GD303 VINYL SIDING SHIELD
- GD2PB 2" TRIM KIT - POLISHED BRASS
- GD2AB 2" TRIM KIT - ANTIQUE BRASS
- GD2C 2" TRIM KIT - CHROME
- GD3PB 3" TRIM KIT - POLISHED BRASS
- GD3AB 3" TRIM KIT - ANTIQUE BRASS
- GD3C 3" TRIM KIT - CHROME 3"
- GD6PB 6" TRIM KIT - POLISHED BRASS
- GD6AB 6" TRIM KIT - ANTIQUE BRASS
- GD6C 6" TRIM KIT - CHROME
- GD43PB 4" - 3D TRIM KIT - POLISHED BRASS
- GD43AB 4" - 3D TRIM KIT - ANTIQUE BRASS
- GA-GD-010.370 WALL SUPPORT ASSEMBLY
- WS-175-1 4" COUPLER
- WS-175-13 7" COUPLER
- WS-660-2 HAND HELD WIRELESS REMOTE SWITCH
- WS-660-011 REMOTE CONTROL - ADVANTAGE PLUS
- WS-660-010 REMOTE CONTROL - ADVANTAGE
- GZ550-1KT BLOWER KIT
- GD65 FAN KIT
- GD36 THERMOSTATIC SENSOR CONTROL FOR USE ONLY WITH GD65
- KB35 VARIABLE SPEED SWITCH
- WS-500-33 V.S.S. MOUNTING PLATE for wall switch
- WS-690-1 MILLIVOLT THERMOSTAT

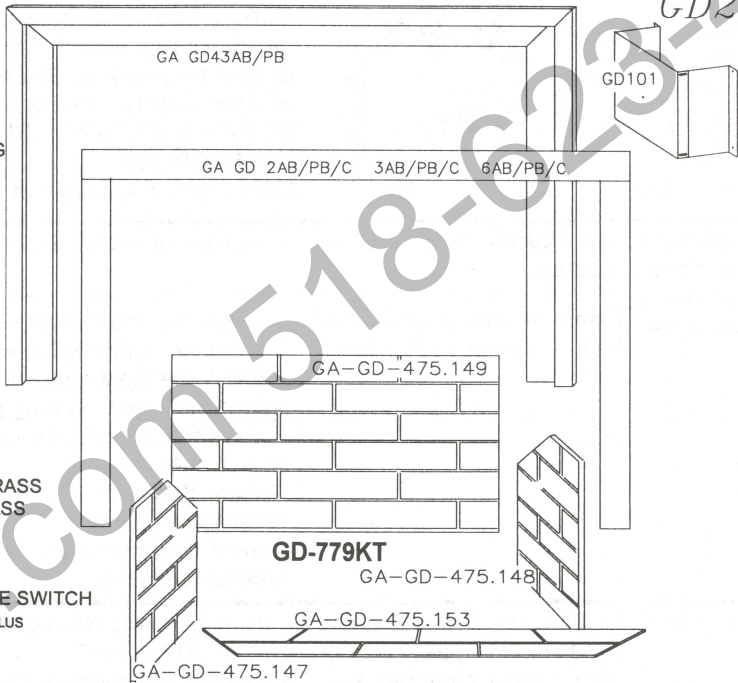

GD-3200 - ONLY

- GD225-K DOOR FACIA - BLACK
- GD225-PB DOOR FACIA - POLISHED BRASS
- GD225-AB DOOR FACIA - ANTIQUE BRASS
- GD225-C DOOR FACIA - CHROME
- GA-GDLPB POLISHED BRASS LOUVRE KIT
- GA-GDLAB ANTIQUE BRASS LOUVRE KIT
- GA-GDLC CHROME LOUVRE KIT
- GD-779KT DECORATIVE BRICK PANEL KIT
- GD202-PB RECTANGULAR DOOR TRIM KIT - POLISHED BRASS
- GD320B-KT BAY WINDOW KIT
- GD250K BLACK WEBBED DOOR FACIA

GD-3200B - ONLY

- GD94-AB LOUVRE / DOOR TRIM KIT - ANTIQUE BRASS

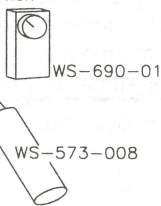

GD225-K / PB / AB / C

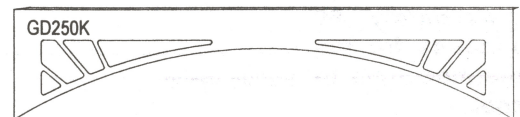
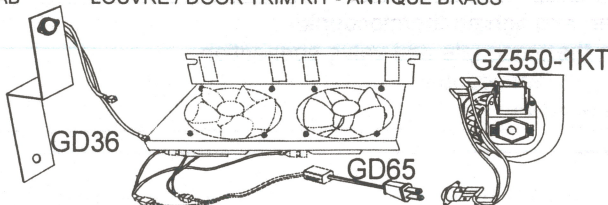
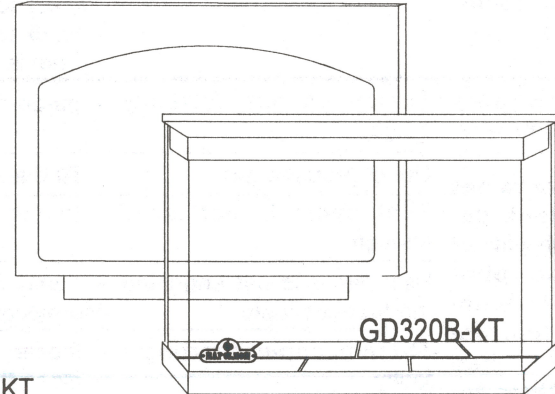

TROUBLE SHOOTING GUIDE

BEFORE ATTEMPTING TO TROUBLESHOOT, PURGE YOUR UNIT AND INITIALLY LIGHT THE PILOT AND THE MAIN BURNER WITH THE GLASS DOOR REMOVED.

SYMPTOM	PROBLEM	TEST SOLUTION
Main burner flame is a blue, lazy, transparent flame.	Blockage in vent. Incorrect installation.	- remove blockage. In really cold conditions, ice buildup may occur on the terminal and should be removed as required. - refer to Figure 13 to ensure correct location of storm collars.
Flames are consistently too large or too small. Carboning occurs.	Unit is over-fired or under-fired.	- check pressure readings: Inlet pressure can be checked by turning screw (A) counter-clockwise 2 or 3 turns and then placing pressure gauge tubing over the test point. Gauge should read 7" (minimum 4.5") water column for natural gas or 13" (11" minimum) water column for propane. Check that main burner is operating on "HI". Outlet pressure can be checked the same as above using screw (B). Gauge should read 3.5" water column for natural gas or 10" water column for propane. Check that main burner is operating on "HI". AFTER TAKING PRESSURE READINGS, BE SURE TO TURN SCREWS CLOCKWISE FIRMLY TO RESEAL. DO NOT OVERTORQUE. Leak test with a soap and water solution.
Carbon is being deposited on glass, logs or combustion chamber surfaces.	Air shutter has become blocked	- ensure air shutter opening is free of lint or other obstructions.
	Flame is impinging on the logs or combustion chamber.	- check that the logs are correctly positioned. - open air shutter to increase the primary air. - check the input rate: check the manifold pressure and orifice size as specified by the rating plate values. - check that the door gasketing is not broken or missing and that the seal is tight. - check that both 4" and 7" vent liners are free of holes and well sealed at all joints. - check that minimum rise per foot has been adhered to for any horizontal venting.
White / grey film forms.	Sulphur from fuel is being deposited on glass, logs or combustion chamber surfaces.	- clean the glass with a gas fireplace glass cleaner. DO NOT CLEAN GLASS WHEN HOT. If deposits are not cleaned off regularly, the glass may become permanently marked.
Exhaust fumes smelled in room, headaches.	Fireplace is spilling.	- check door seal and relief flap seal. - check for chimney blockage - check that chimney is installed to building code. - room is in negative pressure; increase fresh air supply.
Pilot goes out when the gas knob is released. The gas valve has an interlock device which will not allow the pilot burner to be lit until the thermocouple has cooled. Allow approximately 60 seconds for the thermocouple to cool.	System is not correctly purged.	- purge the gas line.
	Out of propane gas.	- fill the tank.
	Pilot flame is not large enough	- turn up the pilot flame.
	Pilot flame is not engulfing the thermocouple.	- gently twist the pilot head to improve the flame pattern around the thermocouple.
	Thermocouple shorting / faulty.	- loosen and tighten thermocouple. - clean thermocouple and valve connection. - replace thermocouple. - replace valve.
	Faulty valve.	- replace.

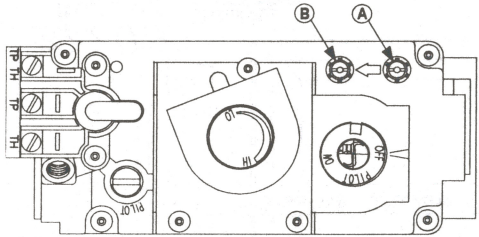

SYMPTOM	PROBLEM	TEST SOLUTION	
Pilot burning; no gas to main burner; gas knob is on 'HI'; wall switch / thermostat is on.	Thermostat or switch is defective.	- connect a jumper wire across the wall switch terminals; if main burner lights, replace switch / thermostat.	
	Wall switch wiring is defective.	- connect a jumper wire across terminals 1 & 3; if the main burner lights, check the wires for defects and / or replace wires.	
	Main burner orifice is plugged.	- remove stoppage in orifice.	
	Faulty valve.	- replace.	
Pilot goes out while standing; Main burner is in 'OFF' position.	Gas piping is undersized.	- turn on all gas appliances and see if pilot flame flutters, diminishes or extinguishes, especially when main burner ignites. Monitor appliance supply working pressure. - check if supply piping size is to code. Correct all undersized piping.	
	Pilot will not light.	No spark at pilot burner	- check if pilot can be lit by a match - check that the wire is connected to the push button ignitor. - check if the push button ignitor needs tightening. - replace the wire if the wire insulation is broken or frayed. - replace the electrode if the ceramic insulator is cracked or broken. - replace the push button ignitor.
Out of propane gas		- fill the tank.	
Spark gap is incorrect		- spark gap should be 0.150" to 0.175" (5/32" to 11/64" approx.) from the electrode tip and the pilot burner. To ensure proper electrode location, tighten securing nut (finger tight plus 1/4 turn).	
No gas at the pilot burner		- check that the manual valve is turned on. - check the pilot orifice for blockage. - replace the valve. - call the gas distributor.	
Main burner goes out; pilot stays on.		Pilot flame is not large enough or not engulfing the thermopile	- turn up pilot flame. - replace pilot assembly.
		Thermopile shorting	- clean thermopile connection to the valve. Reconnect. - replace thermopile / valve.
	Remote wall switch wire is too long; too much resistance in the system.	- shorten wire to correct length or wire gauge.	
	Faulty thermostat or switch.	- replace.	
	Main burner goes out; pilot goes out.	Refer to "MAIN BURNER GOES OUT; PILOT STAYS ON"	
Vent is blocked		- check for vent blockage.	
Vent is re-circulating		- check joint seals and installation.	
Remote wall switch is in "OFF" position; main burner comes on when gas knob is turned to "ON" position.	4" flexible vent has become disconnected from fireplace.	- re-attach to fireplace.	
	Wall switch is mounted upside down	- reverse.	
	Remote wall switch is grounding.	- replace.	
	Remote wall switch wire is grounding.	- check for ground (short); repair ground or replace wire.	
	Faulty valve.	- replace.	

