



**HEARTH PRODUCTS**

This appliance is only for use with the type of gas indicated on the rating plate. This appliance is not convertible for use with other gases, unless a certified kit is used.

**INSTALLER:** Leave this manual with the appliance.  
**CONSUMER:** Retain this manual for future reference.

**INSTALLATEUR:** Laissez cette notice avec l'appareil.  
**CONSOMMATEUR:** Conservez cette notice pour consultation ultérieure.

**WARNING: IF THE INFORMATION IN THIS MANUAL IS NOT FOLLOWED EXACTLY, A FIRE OR EXPLOSION MAY RESULT CAUSING PROPERTY DAMAGE, PERSONAL INJURY OR LOSS OF LIFE.**

Do not store or use gasoline or other flammable vapors or liquids in the vicinity of this or any other appliance.

What to do if you smell gas:

- DO NOT light any appliance.
- DO NOT touch any electrical switches, do not use any phone in your building.
- Immediately call your gas supplier from a neighbor's phone. Follow your gas suppliers instructions.
- If your gas supplier cannot be reached, call the fire department.

Installation and service must be performed by a qualified installer, service agency or the gas supplier.

Tested & Listed By  Portland Oregon USA  
OMNI-Test Laboratories, Inc.

OTL Report No. 116-F-41-5

## INSTALLATION INSTRUCTIONS

# OUTDOOR GAS FIREPLACE ELITE® SERIES

OUTDOOR GAS FIREPLACE  
P/N 850,034M REV. D 04/2009

### MODELS

E360DGNE	E420DGNE
E360DGNE-H	E420DGNE-H
E360DGPE	E420DGPE
E360DGPE-H	E420DGPE-H

A French manual is available upon request. Order Form Number 850,034CF.

Ce manuel d'installation est disponible en français, simplement en faire la demande. Numéro de la pièce 850,034CF.

**AVERTISSEMENT: ASSUREZ-VOUS DE BIEN SUIVRE LES INSTRUCTIONS DONNÉES DANS CETTE NOTICE POUR RÉDUIRE AU MINIMUM LE RISQUE D'INCENDIE D'EXPLOSION OU POUR ÉVITER TOUT DOMMAGE MATÉRIEL, TOUTE BLESSURE OU LA MORT.**

Ne pas entreposer ni utiliser d'essence ni d'autre vapeurs ou liquides inflammables dans le voisinage de cet appareil ou de tout autre appareil.

**QUE FAIRE SI VOUS SENTEZ UNE ODEUR DE GAZ:**

- Ne pas tenter d'allumer d'appareil.
- Ne touchez à aucun interrupteur. Ne pas vous servir des téléphones se trouvant dans le bâtiment où vous vous trouvez.
- Appelez immédiatement votre fournisseur de gaz depuis un voisin. Suivez les instructions du fournisseur.
- Si vous ne pouvez rejoindre le fournisseur de gaz, appelez le service des incendies.

L'installation et l'entretien doivent être assurés par un installateur ou un service d'entretien qualifié ou par le fournisseur de gaz.

## TABLE OF CONTENTS

Packaging .....	page 2
Introduction .....	page 2
New York & Massachusetts Requirements.....	page 3
General Information .....	page 3
Location .....	page 4
Waterproofing The Fireplace .....	page 5
Appliance Clearances .....	page 5
Clearance Specifications .....	page 6
Fireplace Installation .....	page 7
Routing Gas Line .....	page 7
Fireplace Specifications.....	page 8
Framing Specifications.....	page 9
Field Wiring.....	page 10
Connecting Gas Line .....	page 11
Installing The Logs.....	page 12
Checking Appliance Operation .....	page 13
Firebox Finishes .....	page 13
Accessories And Components .....	page 14
<b>Gas Conversion Kits .....</b>	<b>page 15</b>

This installation manual will help you obtain a safe, efficient, dependable installation for your appliance.

This manual is part of a set of two supporting this product. Refer to manual 875,032M for Care And Operations.

**Please read and understand these instructions before beginning your installation.**



We suggest that our gas hearth products be installed and serviced by professionals who are certified in the U.S. by the National Fireplace Institute® (NFI) as NFI Gas Specialists.

## PACKAGING

The assembled outdoor gas fireplace is packaged with the following:

- 1 - the logs are packaged in a carton located within the firebox.

- 2 - one envelope containing the literature package which consists of the Homeowner's manual, Installation Instructions and Warranty.
- 3 - three (3) bags of lave rock, envelope is located in the firebox area.
- 4 - Electrical kit containing the wall switch components, battery holder, box and cover (see Field Wiring page 10).

## INTRODUCTION

These outdoor gas fireplaces are designed for exterior applications. **These appliances must be installed outdoors.**

The Lennox Elite® Series Outdoor Gas Fireplace is designed for outdoor use. It may also be installed in screened porches and lanais that meet these minimum requirements:

Minimum porch area - 96 square feet  
Minimum ceiling height - 7 feet 8 inches

A minimum of two (2) walls can be screened but must be open to outside ventilation.  
Minimum screen area - 64 square feet  
Minimum screen top height - 6 feet 8 inches

Refer to Clearance Specifications on Page 6.

Electronic appliances are designed to operate on natural gas or propane. An electronic intermittent pilot ignition system provides safe, efficient operation. A battery pack is required to operate these units.

These appliances comply with National Safety Standards and are tested by Omni Test Laboratories (Report No. 116-F-41-5) and listed by CSA-4-96 in both USA and Canada, as outdoor gas fireplaces.

The Installation must conform to local codes or, in the absence of local codes, with the *National Fuel Gas Code, ANSI Z223.1/NFPA 54*, or the *Natural Gas and Propane Installation Code, CSA B149.1*.

The appliance, when installed, must be electrically grounded in accordance with local codes or, in the absence of local codes, with the *National Electrical Code, ANSI/NFPA 70*, or the *Canadian Electrical Code, CSA C22.1*.

**DO NOT ATTEMPT TO ALTER OR MODIFY THE CONSTRUCTION OF THE APPLIANCE OR ITS COMPONENTS. ANY MODIFICATION OR ALTERATION MAY VOID THE WARRANTY, CERTIFICATION AND LISTINGS OF THIS UNIT.**

## TYPICAL INSTALLATION

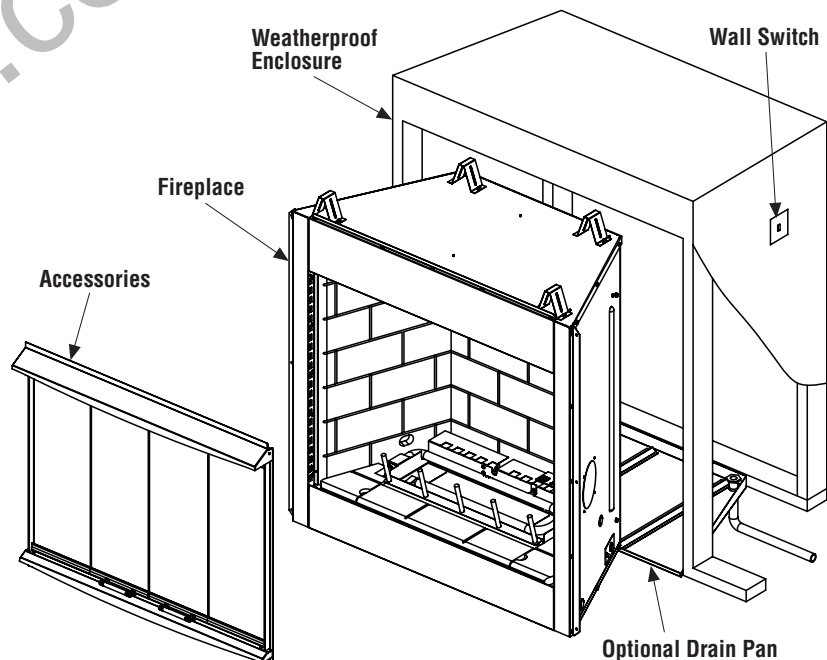


Figure 1

NOTE: DIAGRAMS & ILLUSTRATIONS NOT TO SCALE.

## NEW YORK AND MASSACHUSETTS REQUIREMENTS

These appliances may be installed in the following USA locations with the following requirements:

**Installation of these appliances are approved for installation in the US state of Massachusetts if the following additional requirements are met -**

- Installation and repair must be done by a plumber or gas fitter licensed in the Commonwealth of Massachusetts.
- The flexible gas line connectors shall not exceed 36 inches (92 centimeters) in length.
- The individual manual shut-off must be a t-handle type valve.

## GENERAL INFORMATION

**Note:** Installation and repair should be performed by a qualified service person. The appliance should be inspected annually by a qualified professional service technician. More frequent inspections and cleanings may be required due to yard care, insects, etc. It is imperative that the control compartment and burners of the appliance be kept clean.

Provide adequate clearances around air openings and adequate accessibility clearance for service and proper operation. Never obstruct the front openings of the appliance.

**These appliances are designed to operate on natural or propane gas only.**

### All Models -

All models have a manually modulated gas valve. Input is shown in **Table 1**:

Models with Manually-Modulated Gas Valve			
Natural Gas		Propane Gas	
Model No.	Input rate (BTU/H)	Model No.	Input rate (BTU/H)
E360DG	50,000 to 39,500	E360DG	46,000 to 37,000
E420DG	50,000 to 39,500	E420DG	46,000 to 37,000

**Table 1**

## Gas Pressure - All Models

**Tables 2 and 3** show the appliances' inlet and manifold gas pressure.

Inlet Gas Supply Pressure (all models)		
Fuel #	Minimum	Maximum
Natural Gas	5.0" WC (1.24 kPa)	10.5" WC (2.61 kPa)
Propane	11.0" WC (2.74 kPa)	13.0" WC (3.23 kPa)

**Table 2**

Manifold Gas Supply Pressure (all models)		
Fuel #	Low	High
Natural Gas	(Lo) 2.2" WC (.55 kPa)	(Hi) 3.5" WC (.87 kPa)
Propane	(Lo) 6.3" WC (1.57 kPa)	(Hi) 10.0" WC (2.49 kPa)

**Table 3**

Test gage connections are provided on the front of the gas control valve identified **IN** for the inlet and **OUT** for the manifold side. A 1/8" NPT Test gauge connection is provided at the inlet and outlet side of the electronic gas control valve.

These appliances must be isolated from the gas supply piping system (*by closing their individual manual shut-off valve*) during any pressure testing of the gas supply piping system at test pressures equal to or **less than** 1/2 psig (3.5 kPa).

These appliances and their individual shut-off valves *must be disconnected* from the gas supply piping system during any pressure testing of that system at pressures **greater than** 1/2 psig (3.5 kPa).

## Orifice Sizes - Sea Level To High Altitude (All Models)

These appliances are tested and approved for installation at elevations of 0-4500 feet (0-1372 meters) above sea level, using the standard burner orifice (**See Table 4**). For elevations above 4500 feet, contact your gas supplier or qualified service technician. Install the appliance according to the regulations of the local authorities having jurisdiction and, in the USA, the National Fuel Gas Code NFPA 54 / ANSI Z223.1 - latest edition or, in Canada, the CAN1-B149.1 and .2 codes - latest edition.

Model No.	Orifice size		Elevation Feet (meters)
	Natural Gas	Propane	
E360DG	0.1405" (#28)	0.0785" (#47)	0-4500 (0-1372)
E420DG	0.1405" (#28)	0.0785" (#47)	

**Table 4**

**WARNING: PROPANE TANKS ARE AT PRESSURES THAT WILL CAUSE DAMAGE TO VALVE COMPONENTS. VERIFY THAT THE TANKS HAVE STEP DOWN REGULATORS TO REDUCE THE PRESSURE TO SAFE LEVELS.**

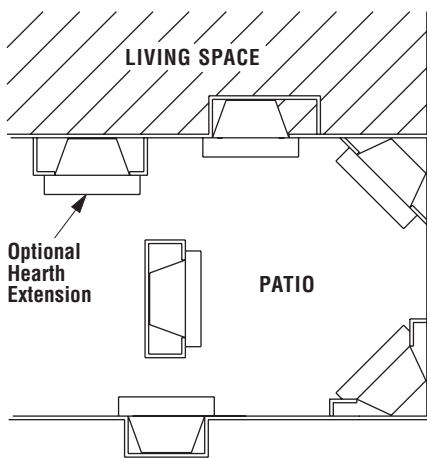
## ASSEMBLY OUTLINE

### Before You Start

Check your inventory list to be sure you have all the necessary parts supplied in good usable condition. Check also for any concealed damage.

### LOCATION OF FIREPLACE

Carefully select the proper location for any obstructions, clearance to side wall(s), air availability, location and aesthetics. With proper pre-planning, a slight adjustment of a few inches can save considerable time and expense later during construction and assembly. See **Figure 2** for some examples.



**Figure 2**

When choosing a location, care must be taken to avoid places where flooding or running water may be a problem.

Identify the desired location for the battery pack/ON/OFF switch junction box location. This should be easily accessible and convenient for use and high enough on the wall to be protected from water and drifted snow.

Do not use these appliances if any part of the gas supply, control or burner has been submerged under water. Immediately call a qualified, professional service technician to inspect the appliance and to replace any parts of the control system and any gas control which have been under water.

Carefully consider the position of the fireplace opening with respect to the location of adjacent or nearby stairwells, doors, windows, walkways and over hanging trees, patios and wires.

When locating the fireplace, consideration must be given to combustibles and final finishing. See **Figure 18** and confine the final location of combustible finish materials to the "Safe Zone". Also refer to Clearance Specifications on page 6.

Consider the effects of heat when locating any object in front of or near the fireplace opening.

### PRE-INSTALLATION NOTES

The fireplace may be installed directly on a combustible floor or raised on a platform of an appropriate height. Do not place the fireplace on vinyl or other soft floor coverings. It may, however, be placed on flat wood, plywood, particle board or other hard surfaces.

Position the electrical junction box as detailed in **LOCATION OF FIREPLACE**. (The umbilical cord is 9 feet long).

Be sure the fireplace rests on a solid continuous floor or platform with appropriate framing for support.

The fireplace may be positioned and then the framing built around it, or the framing may be constructed and the fireplace positioned into the opening.

Usually, no special floor support is needed for the fireplace, however, to be certain:

1. Estimate the total weight of the fireplace system including surround materials such as brick, stone, etc., to be installed. Shipping weights for the fireplace may be found on page 8.

2. Measure the square footage of the floor space to be occupied by the system, surrounds and hearth extensions.

3. Note the decking construction, i.e. 2 x 6's, 2 x 8's or 2 x 10's, single or double joists, type and thickness of floor boards.

4. Use this information and consult your local building code to determine if you need additional support.

If you plan to raise the fireplace and hearth extension, build the platform assembly then position fireplace and hearth extension on top. Secure the platform to the floor to prevent possible shifting.

## ASSEMBLY STEPS

**Note:** The following steps represent the normal sequence of installation. Each installation is unique, however, and might require a different sequence.

1. Position firebox prior to framing or into prepared framing (non-combustible framing is recommended).

2. Position the electrical junction box as detailed in **LOCATION OF FIREPLACE**. (The umbilical cord is 9 feet long).

3. Waterproof the fireplace or install the optional drip pan (see *Waterproofing The Fireplace and Figure 3* on page 5).

4. Plumb gas line. (Gas connections should only be performed by an experienced, licensed/certified tradesman.)

5. Complete the installation, finish wall material, surround and hearth extension to your individual taste.

6. Assemble and attach optional accessories.

Study the three dimensional illustration (**Figure 1**) to get a general idea of each element of your fireplace system.

### WATERPROOFING THE FIREPLACE

Although the fireplace is designed to operate safely outdoors, rain may enter the hearth area, condensation and can cause water to collect inside the fireplace bottom.

**To prevent water collection, the builder must provide a means to drain water from under the fireplace by building or installing a water collector of the builders choice, before positioning the fireplace in its location.**

Special care must be taken when the fireplace is installed against an exterior wall. The enclosure surrounding the fireplace on the sides and back must be treated as an exterior wall.

Lennox does provide an optional drain pan to assist weatherproofing the fireplace.

H4651 DPSS36 Drain Pan for E36ODG, H4652 DPSS42 Drain Pan for E42ODG.

When Planning for the installation of the fireplace, the framing height must be increased from 46-1/2 inches to 47-1/4 inches, when installing the drain pan. An additional space below the fireplace will also be required to plumb a drain line.

**Step 1.** Seal all joints, gaps and corners around the bottom of the drain pan before positioning the fireplace on its location (*Figure 3*).

**Step 2.** On the exposed drain hole, install a PVC threaded coupling reducer, 3/4" x 1/2" going from the top of the pan down through the hole. Apply a silicone-based sealant around the base and threads before installation.

**Step 3.** Holding the reducer coupling with a wrench, thread a 3/4", 90 degree, PVC elbow to the reducer until it is tight to the metal.

**Step 4.** Add additional piping to route the drain to an appropriate location.

**Note:** To assure proper drainage, the fireplace must be installed on a leveled surface.

### CLEARANCES

Minimum clearance to combustibles for the fireplace is as follows; sides and back – 1/2" (13mm), combustible floor – 0" (0mm), adjacent wall 6" (152mm), ceiling – 50" (1270mm). Refer to *Figure 4* on this page and *Figure 18* on page 13 for more detail.

**Note:** Clearance behind the nailing flange for both fireplace models is 1/2" (13mm).

**Note:** Adjacent wall considerations are for an adjacent wall to only a single side. Walls should not be placed at the minimum distance on both sides of the fireplace. Allow at least 4 feet on one side of the fireplace.

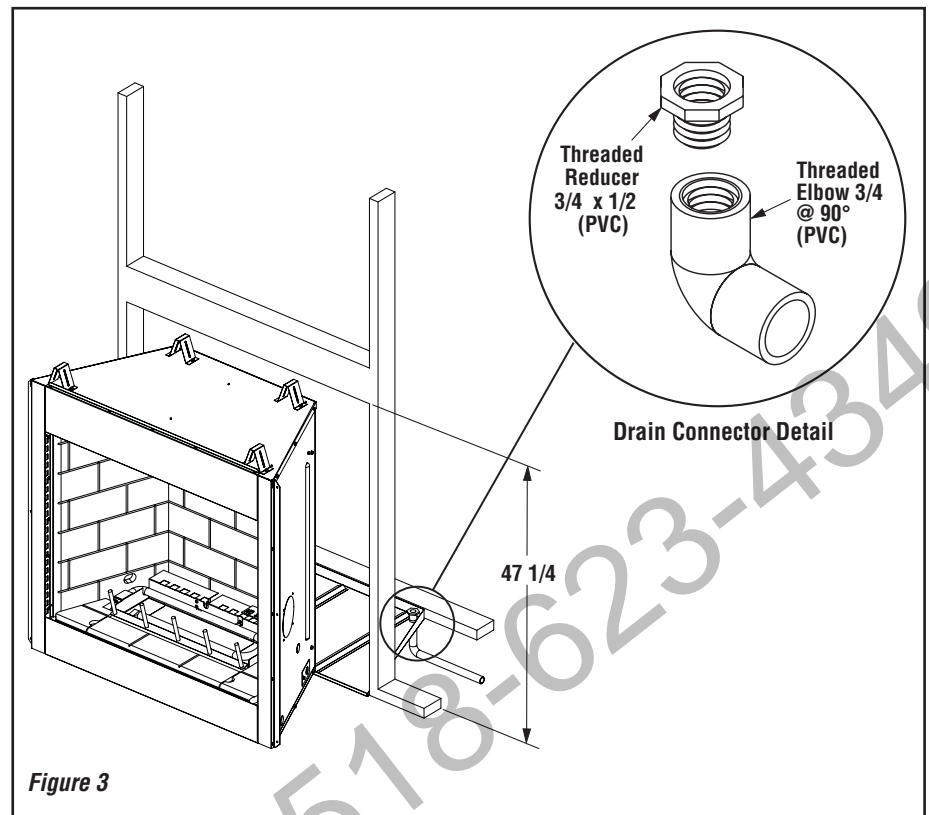


Figure 3

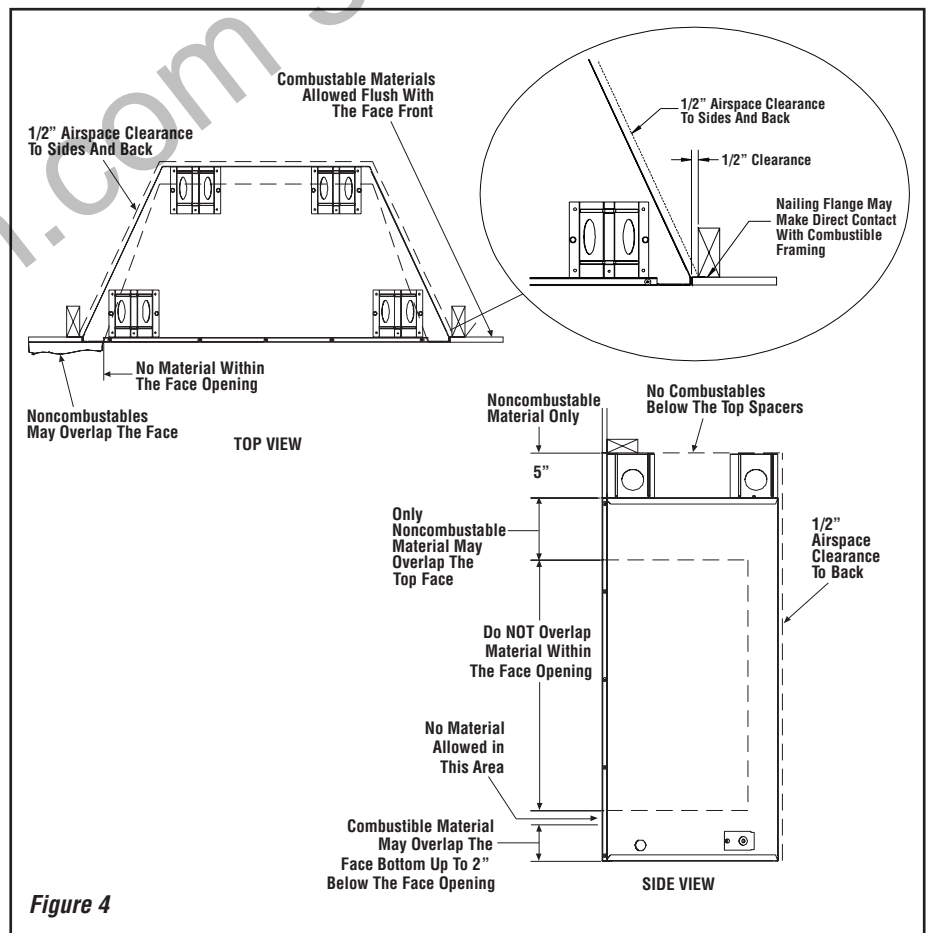
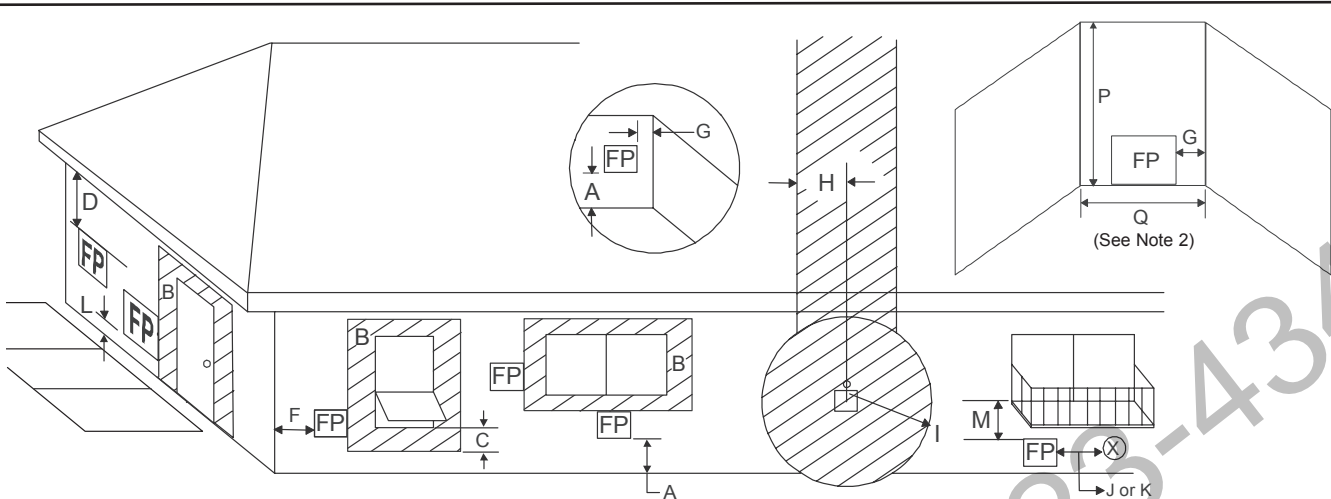


Figure 4

# CLEARANCE SPECIFICATIONS



**FP** = FIREPLACE OPENING    **(X)** = AIR SUPPLY INLET    **[Hatched Box]** = AREA WHERE FIREPLACE IS NOT PERMITTED

A	= 2 in. . . . .	clearances above grade, veranda, porch, deck or balcony.	I	= 3 ft. (USA) . . . . .	clearance to service regulator vent outlet and electric service.
B	= 12 in. . . . .	clearances to window or door that may be opened, or to permanently closed window.	J	= 9 in. (USA) . . . . .	clearance to non-mechanical air supply inlet to building or the combustion air inlet to any other appliance.
	36 in. . . . .	vinyl windows or siding.	K	= 3 ft. (USA) . . . . .	clearance to a mechanical air supply inlet.
C	= 72 in. . . . .	clearance below an operable window.	L*	= 54 in. . . . .	clearance above paved sidewalk or a paved driveway located on public property.
D	= 47 in. . . . .	vertical clearance to unventilated soffit or to ventilated soffit located above the fireplace.	M**	= 47 in. . . . .	clearance under veranda, porch, deck, balcony or overhang.
	60 in. . . . .	vinyl clad soffits.		Not allowed: . . . . .	vinyl.
F	= 9 in. . . . .	clearance to outside corner.	P	= 92 in.	
G	= 6 in. . . . .	clearance to inside corner.	Q	= 72 in.	
	48 in. . . . .	vinyl windows or siding.			
H	= 3 ft. (Canada) . . . . .	not to be installed above a gas meter/regulator assembly within 3 ft (914 mm) horizontally from the center line of the regulator.			

\* A fireplace shall not open directly above a sidewalk or paved driveway which is located between two single family dwellings and services both dwellings.  
 \*\* Only permitted if veranda, porch, deck or balcony is fully open on a minimum of 2 sides beneath the floor, or if the screened porch guidelines are followed.

**Note 1:** Local codes or regulations may require different clearances.  
**Note 2:** Fireplaces in an alcove space (spaces open only on one side and with an overhang) are permitted with the dimensions specified for vinyl or non-vinyl siding and soffits. **1)** There must be a 3 ft minimum between terminations or between the fireplace and termination. **2)** All mechanical air intakes within 10 ft of the top of the fireplace opening must be a minimum of 3 ft below the top of the fireplace opening.

**3)** All gravity air intakes within 3 ft of the fireplace must be a minimum of 1 ft below the face top opening.  
 This fireplace is approved for installation in screened porches with the following guidelines:  
 Minimum porch area - 96 sq ft  
 Minimum ceiling height - 92 in.  
 Minimum of two walls must be screened or open  
 Minimum top of screen height, side walls - 6 ft 8 in.  
 Minimum screen area - 64 sq ft

**Note:** There may be some odor and small amounts of soot associated with burning the fireplace in a screened porch. Ensuring good cross draft ventilation and routine maintenance of the fireplace will maximize comfort and cleanliness.

## FIREPLACE INSTALLATION

**Step 1.** Frame these appliances as illustrated in **Figures 7 through 9**. All framing details must allow for a minimum clearance to combustible framing members, as shown in **Figure 4 on page 5**. Also refer to Fireplace Specifications on Page 8. Headers may be in direct contact with the appliance top spacers but must not be supported by them or notched to fit around them. All construction above the appliance must be self supporting. **DO NOT USE THE APPLIANCE FOR STRUCTURAL SUPPORT.**

**Note:** The framed depth from a framed wall, must always be measured from a finished surface. If a wall covering such as durrock is to be attached to the rear wall, then the depth must be measured from the wall surface. It is important that this dimension be exact.

**Note:** Non-combustible framing members are not required, but are recommended.

**Step 2.** Level the firebox by checking the top edge of the firebox. Shim if necessary.

**Step 3.** The fireplace should be secured to the side framing members, using the full length nailing flange located on both sides of the fireplace. Use 8d nails, or screws.

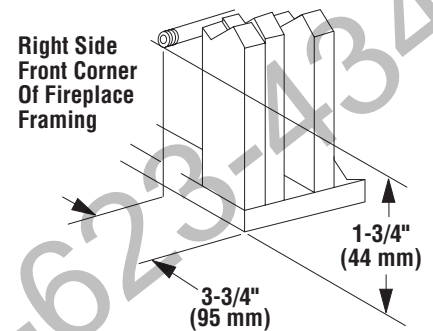
**IMPORTANT: UNDER NO CIRCUMSTANCES SHALL THE FIREBOX TOP SPACERS BE REMOVED OR MODIFIED. THE HEADER MAY BE IN DIRECT CONTACT WITH THE TOP SPACERS BUT MUST NOT BE SUPPORTED BY THEM OR NOTCHED TO FIT AROUND THEM.**

**Step 4.** Identify the desired location for the battery pack/ON/OFF switch junction box. This should be easily accessible and convenient for use. Avoid installing where the opening could be blocked by snow, bushes, etc. Also, considerations need to be made to avoid water infiltration. The electrical junction box must be positioned within range of the electrical umbilical cord (9 feet). Route the umbilical cord to the box to ensure proper length. Secure the umbilical cord per appropriate local and national electrical codes.

## ROUTING GAS LINE

Route a 1/2" (13 mm) gas line along the inside of the right side framing as shown in **Figure 5**. Gas lines must be routed, constructed and made of materials that are in strict accordance with local codes and regulations.

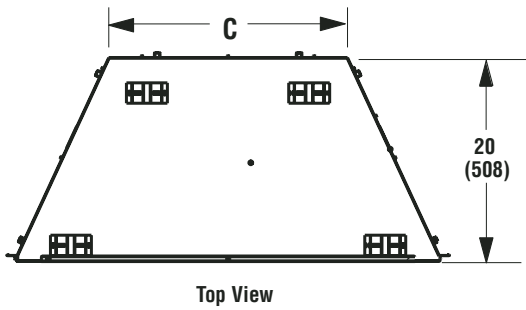
All appliances are factory-equipped with a flexible gas line connector and 1/2 inch shutoff valve. (See **Figure 12 on page 11**).



**Figure 5**

**Note:** An additional inlet has been provided on the left side (see **Figure 6**).

# FIREPLACE SPECIFICATIONS



Dimensions - Inches (millimeters)			
Model No.	A	B	C
E360DG	37 (940)	41-3/4 (1061)	23-1/2 (597)
E420DG	43 (1092)	47-3/4 (1213)	29-1/2 (749)

Weight And Volume		
Model	Ship. Weight (lbs)	Shipping Volume
E360DG	200 lbs	35 Cu. Ft.
E420DG	230 lbs	38 Cu. Ft.

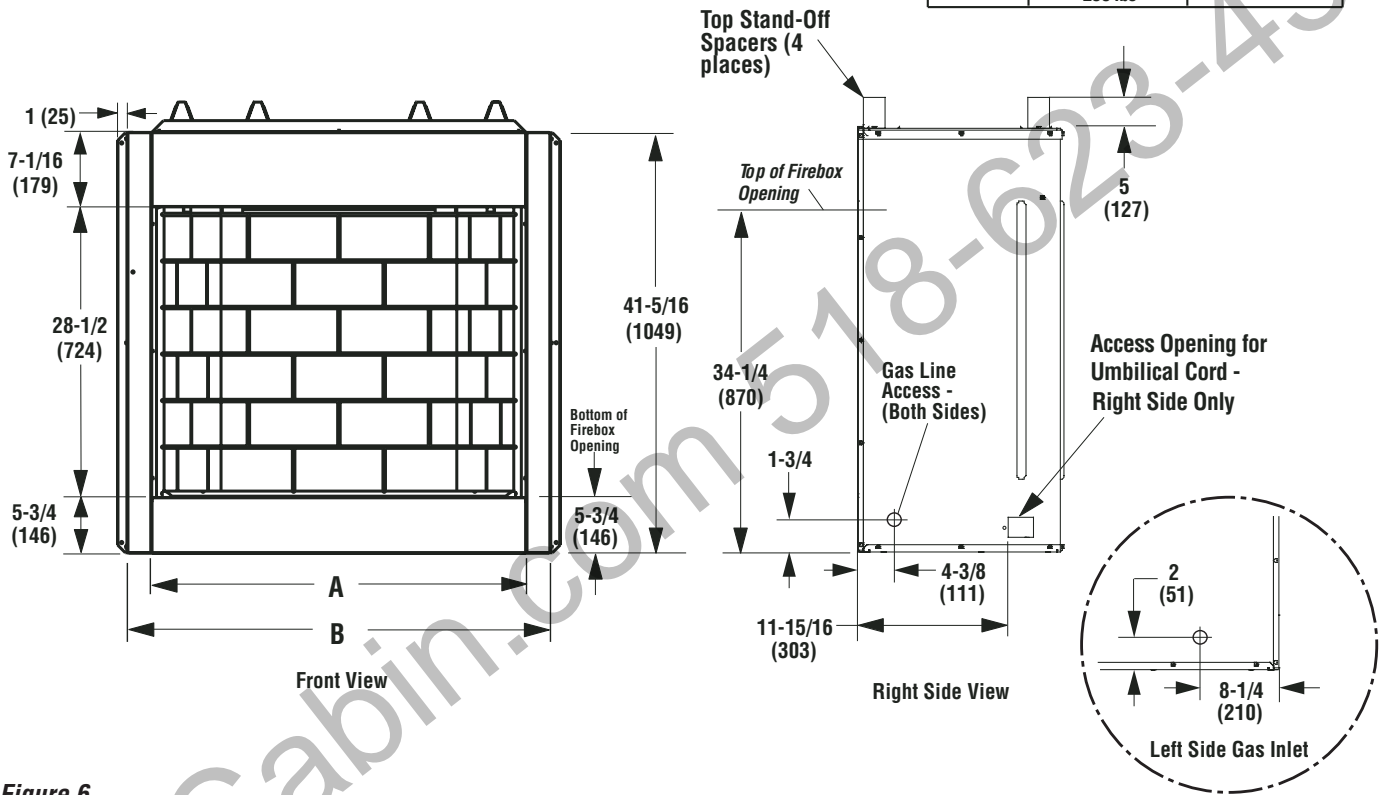
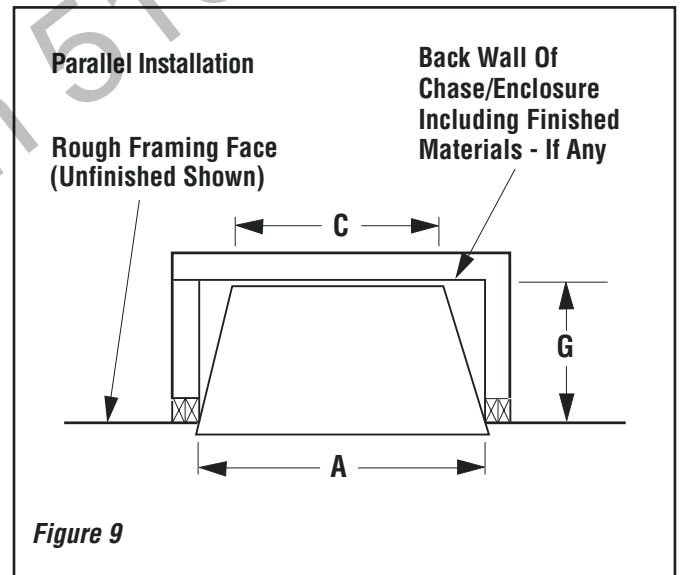
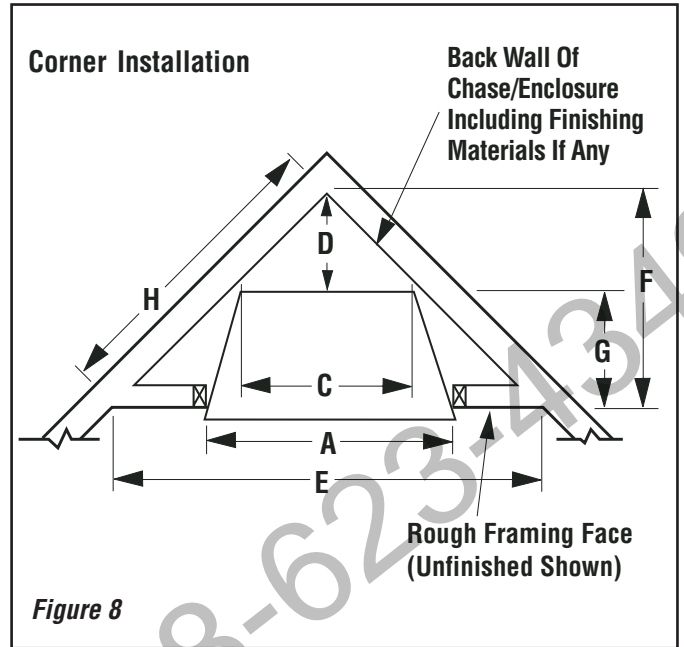
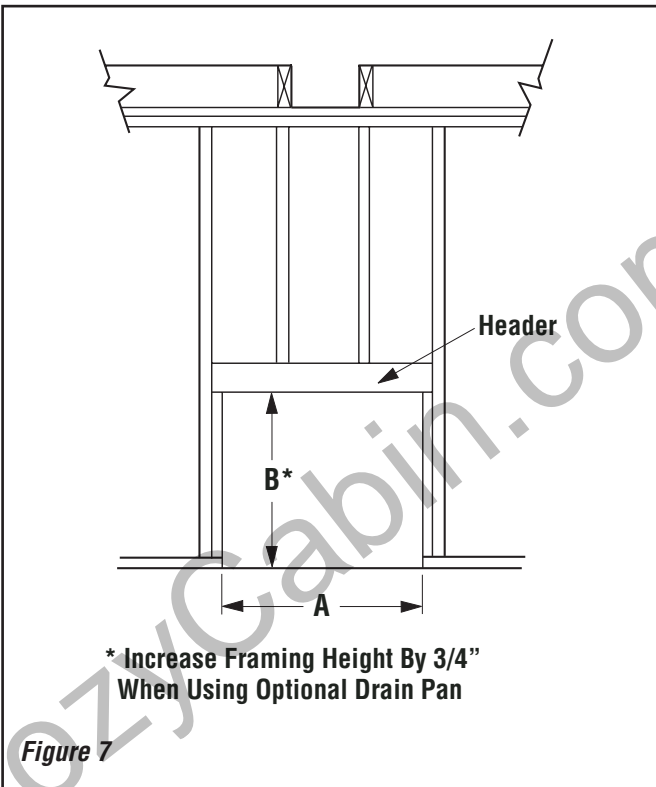


Figure 6

# FRAMING SPECIFICATIONS

Opening	E360DG	E420DG
A	42-3/4" (1086)	48-3/4" (1238)
B	46-1/2" (1181)	46-1/2" (1181)
C	23-9/16" (599)	29-9/16" (751)
D	11-1/4" (286)	14-1/4" (362)
E	63-1/2" (1613)	69-1/2" (1765)
F	31-3/4" (807)	34-3/4" (883)
G	20-1/2" ( 521)	20-1/2" ( 521)
H	44-3/16" (1122)	49-1/8" (1248)

Table 1 (This Table Corresponds To Figures 7, 8 & 9.)



Figures 7, 8 & 9 Correspond To Table 1.

## FIELD WIRING

**Caution: Label all wires prior to disconnection when servicing controls. Wiring errors can cause improper and dangerous operation. Verify proper operation after servicing.**

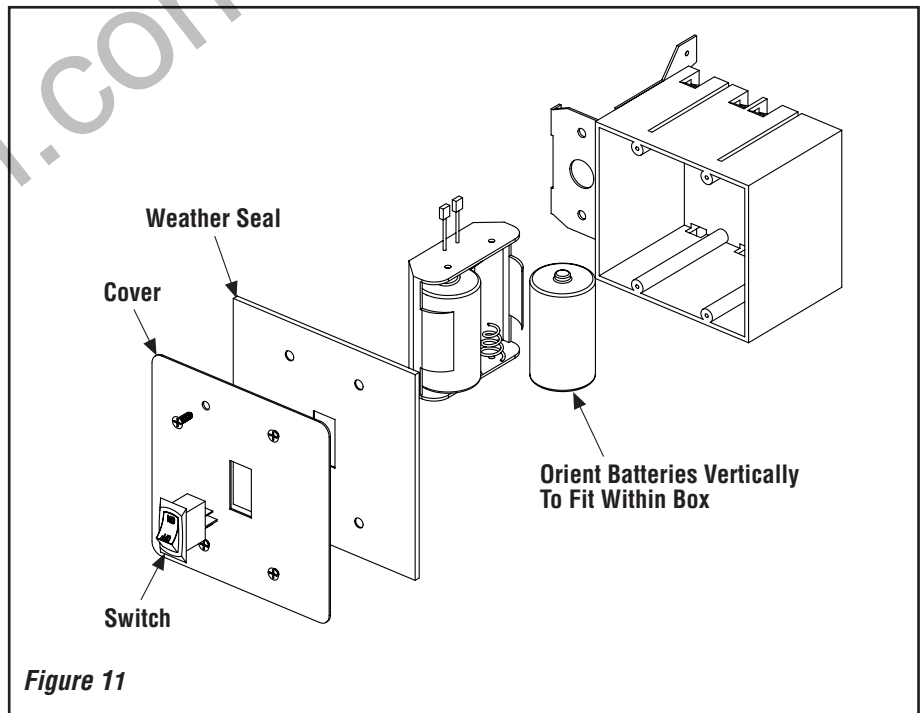
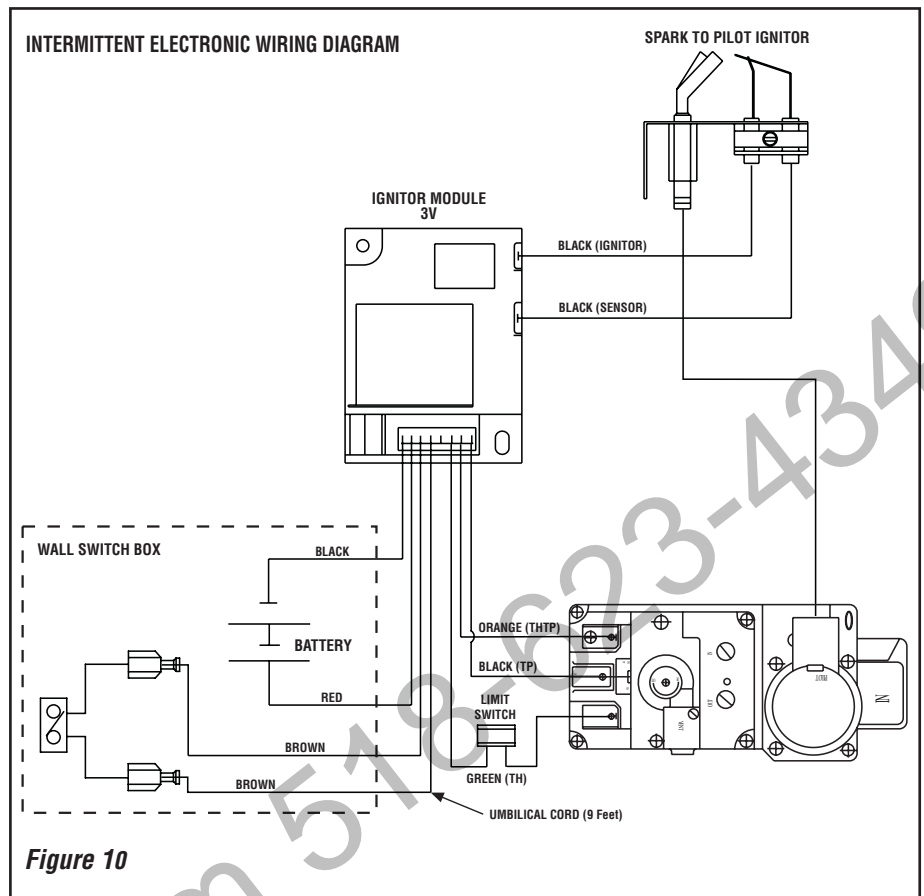
Refer to **Figure 10** for the wiring schematic for these fireplaces.

This fireplace is completely wired internally. On the right hand side of the fireplace, at the rear, are four (4) wires required to connect the Battery and switch for operation.

Two brown wires are for the connection of the switch. These are labeled SW and SW. A black and red pair are for connection to the battery pack. These are labeled (+) and (-).

These wires are for low voltage current. An electrical box has been provided to contain both the switch and battery pack. Mount the box in an appropriate location within the length of the wiring provided. Feed all four wires through one of the lower inlets to the box. Connect the switch wires to the switch and the corresponding (+), (-) to the battery holder.

Install two D-cell batteries (not provided) and test the switch before closing the switch box (refer to **Figure 11**). The igniter should spark to the pilot when the switch is on.



## CONNECTING GAS LINE

Codes require a shut-off valve mounted in the supply line. **Figure 12** illustrates two methods for connecting the gas supply. The flex-line method is acceptable in the U.S., however, Canadian requirements vary depending on locality. Installation must be in compliance with local codes.

These appliances are equipped with a gas flex line for use (where permitted) in connecting the unit to the gas line. A gas flex line is provided to aid in attaching the direct vent appliance to the gas supply. The gas flex line can only be used where local codes permit. See **Figure 12** for flex line description. The flex line is rated for both natural and propane gas. A manual shut off valve is also provided with the flex line.

The gas control valve is located under the refractory cover in front of the burner.

To access the valve, lift out the center refractory and remove the access cover (**see Figure 13**).

The control valves have a 3/8" (10 mm) NPT thread inlet port.

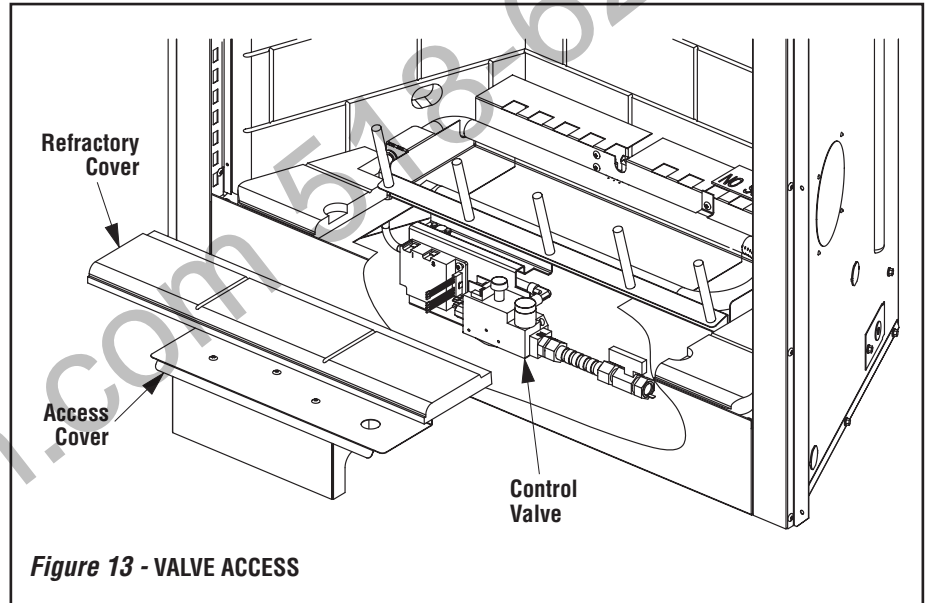
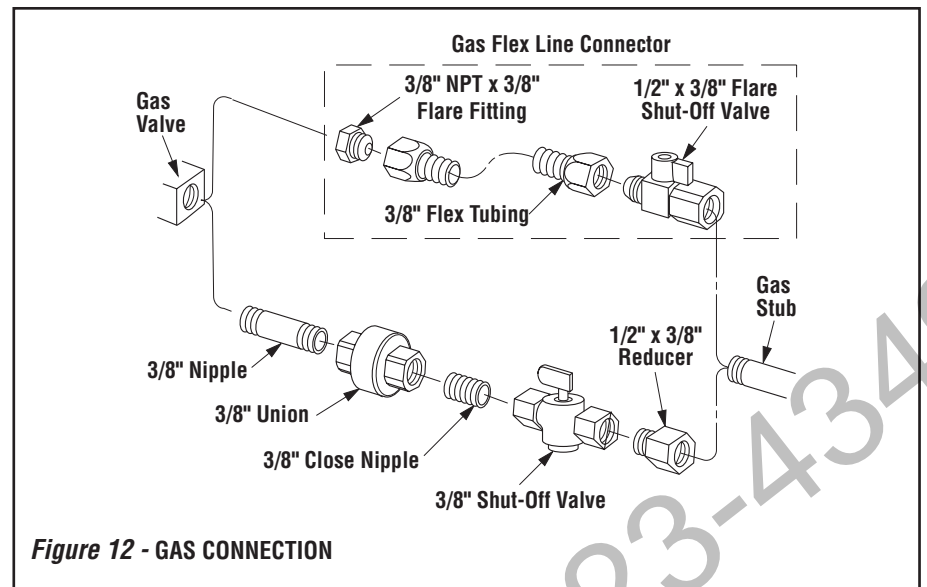
**Secure all joints tightly using appropriate tools and sealing compounds (ensure propane resistant compounds are used in propane applications).**

Turn on gas supply and test for gas leaks, using a gas leak test solution (also referred to as bubble leak solution). **Note:** Using a soapy water solution (50% dish soap, 50% water) is an effective leak test solution but it is not recommended, because the soap residue that is left on the pipes/fittings can result in corrosion over time. **Never use an open flame to check for leaks.**

**A.** Light the appliance (refer to the lighting instructions label in the control compartment or in the Homeowner's Care and Operation Instructions).

**B.** Brush all joints and connections with the gas leak test solution to check for leaks. If bubbles are formed, or gas odor is detected, turn the gas control knob to the "OFF" position. Either tighten or refasten the leaking connection and retest as described above.

**C.** When the gas lines are tested and leak free, be sure to rinse off the leak testing solution.



**WARNING: DO NOT OPERATE THE FIREPLACE FOR ANY EXTENDED PERIOD OF TIME WITHOUT THE LAVA ROCK IN PLACE. THE PAN CAN OVER HEAT AND MAY WARP AND THE FIREPLACE MAY SHUT OFF AUTOMATICALLY.**

## INSTALLING THE LOGS

After verifying that the fireplace operates properly, replace the cover and set the bottom refractory components in place.

Use two (2) bags of lava rock to fill the bottom of the burner tray to completely cover the burner tube. Level the rock evenly.

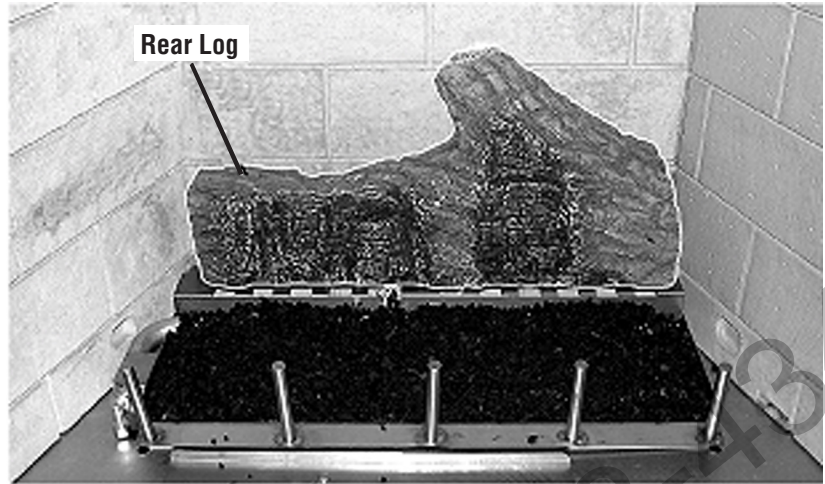
Place the rear log approximately centered as shown in **Figure 14**.

Place the base log approximately as shown in **Figure 15**.

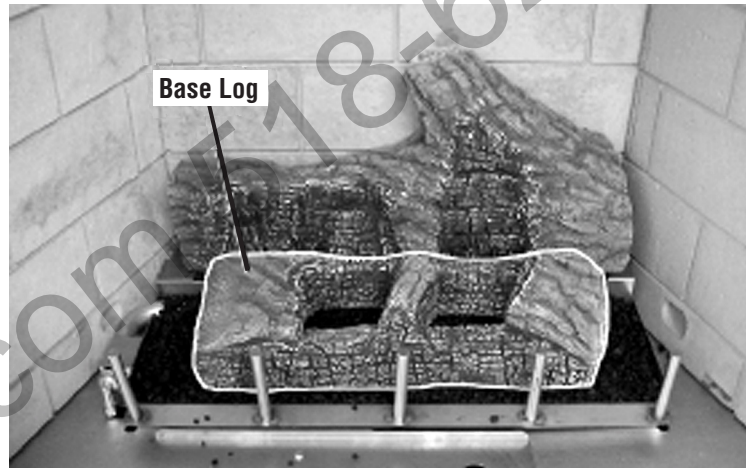
The remaining logs can be placed across the rear and base log approximately as shown in **Figure 16**. **The exact position of these logs is not critical.** Due to the nature of an outdoor environment, the flame will never be strictly controlled. You may need to reposition the logs to get the effect you find most desirable.

A more detailed description is provided in the Homeowners Care and Operations manual.

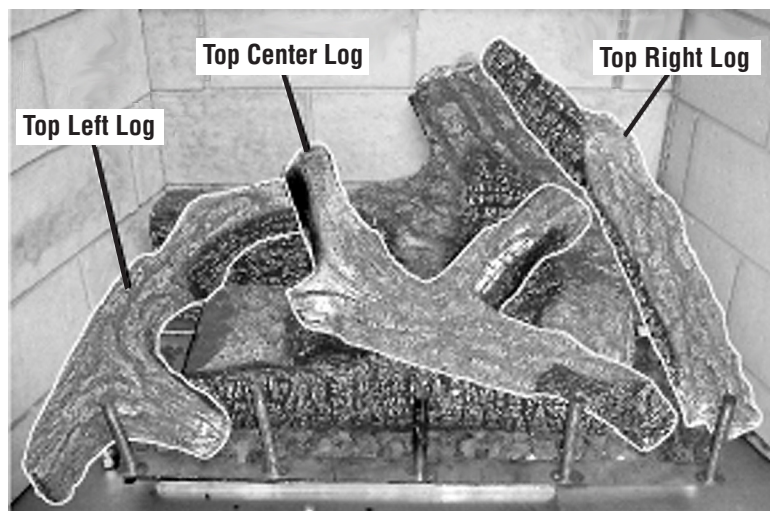
**CAUTION: LOGS GET HOT WHILE THE FIREPLACE IS IN OPERATION. DO NOT ATTEMPT TO ADJUST OR MOVE THE LOGS WHILE THE FIREPLACE IS HOT.**



**Figure 14**



**Figure 15**



**Figure 16**

NOTE: DIAGRAMS & ILLUSTRATIONS NOT TO SCALE.

## CHECKING APPLIANCE OPERATION

With gas line installed run initial system check-out before installing any additional accessories. Follow the lighting instructions provided in the Care and Operation Instructions.

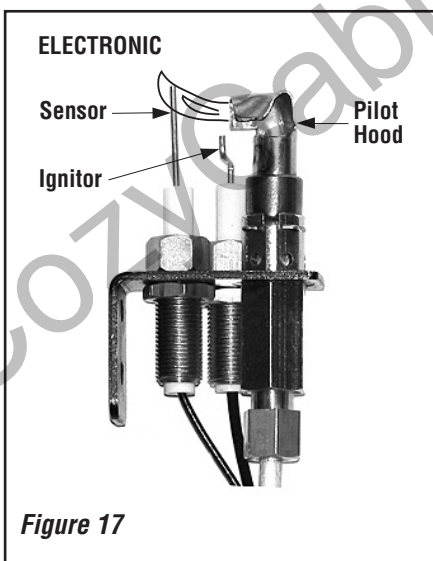
**Note:** Lighting Instructions are also found on the literature tag tied to the gas piping next to the gas valve. To access the tag, open the lower control compartment door (refer to **Figure 13 - Valve Access**).

When first lighting the appliance, it will take a few minutes for the line to purge itself of air. Once purging is complete, the pilot and burner will light and operate as indicated in the instruction manual. Subsequent lighting of the appliance will not require such purging. Inspect the pilot flame (remove logs, if necessary, handling carefully).

After the logs have been placed and the fireplace has been checked for proper flame presentation, use the remaining rock to fill in voids and spaces. Remember, you may need to access the high/low flame control beneath the refractory cover.

## Electronic Appliance Checkout

To light the burner, turn 'ON' the remote wall switch. The battery will energize a spark that will light the pilot. The pilot flame will engulf the sensor and open the main valve. Within seconds the main burner will light. Ensure the ignitor lights the pilot. The pilot flame should engulf the sensor as shown in **Figure 17**.



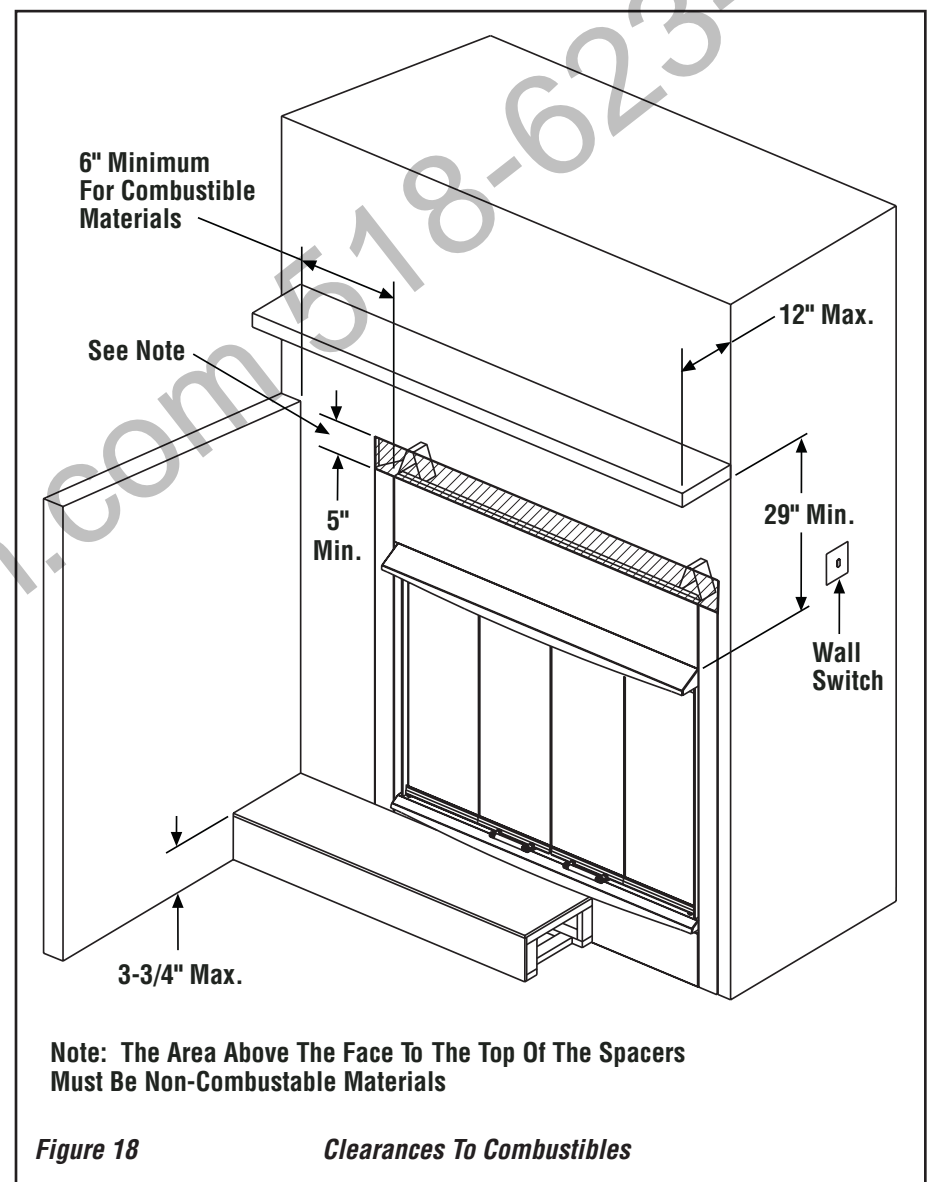
**Carbon Monoxide Poisoning:** Early signs of carbon monoxide poisoning are similar to the flu with headaches, dizziness and/or nausea. If you have these signs, obtain fresh air immediately. Turn off the gas supply to the appliance and have it serviced by a qualified professional, as it may not be operating correctly.

## FIREBOX FINISHES

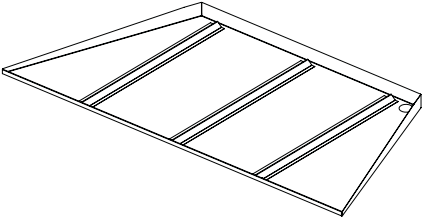
There are a wide variety of "finished looks" for your outdoor fireplace, from formal wall decor with elaborate mantels to rustic wood paneling or warm brick facings.

Only noncombustible materials like marble, stone, tile, brick, etc. may overlap the top and sides of the front facing. Seal all joints between the black facing and wall surrounds to prevent air intrusion. Use noncombustible caulking materials only to seal the metal facing to the surround material on the finished wall. See **Figure 18**.

**CAUTION: DO NOT BLOCK THE FACE OPENING ON THESE FIREBOXES. DOING SO MAY CREATE A POTENTIAL FIRE HAZARD.**



## INSTALLATION ACCESSORIES AND COMPONENTS



### Drain Pan

The drain pan is used with the appliance.

Drain Pan		
Cat. No.	Model	Description
H4651	DPSS36	Drain Pan (36)
H4652	DPSS42	Drain Pan (42)

## GAS CONVERSION KITS

**WARNING: THIS CONVERSION KIT SHALL BE INSTALLED BY A QUALIFIED SERVICE AGENCY IN ACCORDANCE WITH THE MANUFACTURER'S INSTRUCTIONS AND ALL APPLICABLE CODES AND REQUIREMENTS OF THE AUTHORIZED HAVING JURISDICTION. IF THE INFORMATION IN THESE INSTRUCTIONS IS NOT FOLLOWED EXACTLY, A FIRE, EXPLOSION OR PRODUCTION OF CARBON MONOXIDE MAY RESULT CAUSING PROPERTY DAMAGE, PERSONAL INJURY OR LOSS OF LIFE. THE INSTALLATION IS NOT PROPER AND COMPLETE UNTIL THE OPERATION OF THE CONVERTED APPLIANCE IS CHECKED AS SPECIFIED IN THE OWNER INSTRUCTIONS SUPPLIED WITH THE KIT. THE QUALIFIED SERVICE AGENCY PERFORMING THIS INSTALLATION ASSUMES RESPONSIBILITY FOR THIS CONVERSION.**

**AVERTISSEMENT: CET ÉQUIPEMENT DE CONVERSION SERA INSTALLÉ PAR UNE AGENCE QUALIFIÉE DE SERVICE CONFORMÉMENT AUX INSTRUCTIONS DU FABRICANT ET TOUTES EXIGENCES ET CODES APPLICABLES DE L'AUTORISÉS AVOIR LA JURIDICTION. SI L'INFORMATION DANS CETTE INSTRUCTION N'EST PAS SUIVIE EXACTEMENT, UN FEU, EXPLOSION OU PRODUCTION DE PROTOXYDE DE CARBONE PEUT RÉSULTER LE DOMMAGES CAUSER DE PROPRIÉTÉ, PERTE OU BLESSURE PERSONNELLE DE VIE. L'AGENCE QUALIFIÉE DE SERVICE EST ESPONSABLE DE L'INSTALLATION PROPRE DE CET ÉQUIPEMENT. L'INSTALLATION N'EST PAS PROPRE ET COMPLÈTE JUSQU'À L'OPÉRATION DE L'APPAREIL CONVERTI EST CHÉQUE SUIVANT LES CRITÈRES ÉTABLIS DANS LES INSTRUCTIONS DE PROPRIÉTAIRE PROVISIONNÉES AVEC L'ÉQUIPEMENT.**

### In Canada:

THE CONVERSION SHALL BE CARRIED OUT IN ACCORDANCE WITH THE REQUIREMENTS OF THE PROVINCIAL AUTHORITIES HAVING JURISDICTION AND IN ACCORDANCE WITH THE REQUIREMENTS OF THE CAN1-B149.1 AND .2 INSTALLATION CODE.

LA CONVERSION DEVRA ÊTRE EFFECTUÉE CONFORMÉMENT AUX RECOMMANDATIONS DES AUTORITÉS PROVINCIALES AYANT JURIDICTION ET CONFORMÉMENT AUX EXIGENCES DU CODE D'INSTALLATION CAN1-B149.1 ET.2.

Gas conversion kits are available to adapt your appliance from the use of one type of gas to the use of another. These kits contain all the necessary components needed to complete the task including labeling that must be affixed to ensure safe operation.

Kit part numbers are listed here and the following steps detail the conversion procedure.

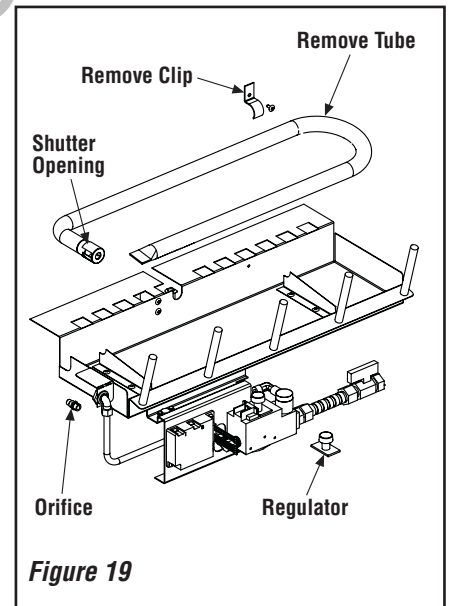
**Step 1.** Turn off the gas supply to the appliance.

**Step 2.** Carefully remove the logs. Exercise care so as not to break the logs.

**Step 3.** Refer to *Figure 19*. Remove the burner assembly with attached venturi tube.

Natural To Propane Gas Conversion Kit		
Models No.	Unit Type	Catalog No.
E360DG	GCK-DB078P	H4916
E420DG	GCK-DB078P	H4916

Propane to Natural Gas Conversion Kit		
Model No.	Unit Type	Catalog No.
E360DG	GCK-DB140N	H4915
E420DG	GCK-DB140N	H4915



**Figure 19**

## Electronic Appliances

**Step 4. Dexen Electronic Valves** - See **Figure 20** and the instructions provided with the kit. Remove and discard the two pressure regulator mounting screws. Remove the pressure regulator and diaphragm. Discard all removed components. **Ensure the rubber gasket installed on the back of the replacement pressure regulator is properly positioned.** Install the new pressure regulator using the new screws supplied with the kit. Tighten screws to 25 in. lb. torque.

**Note:** Natural gas regulators are identified with a blue dot. Propane regulators have a red dot.

**Step 5.** See **Figure 21** and replace the pilot orifice as follows: Remove pilot hood assembly by grasping the hood and pulling the assembly straight up. Under the hood is the pilot orifice. With caution and using a magnetic screwdriver, undo the pilot orifice and remove it from the assembly. Carefully replace the orifice with the one provided with the kit. Press the pilot hood back over the assembly. The orientation should be aligned as shown in **Figure 21**. **Exercise extreme care to prevent damage to or breakage of the ignitor assembly.**

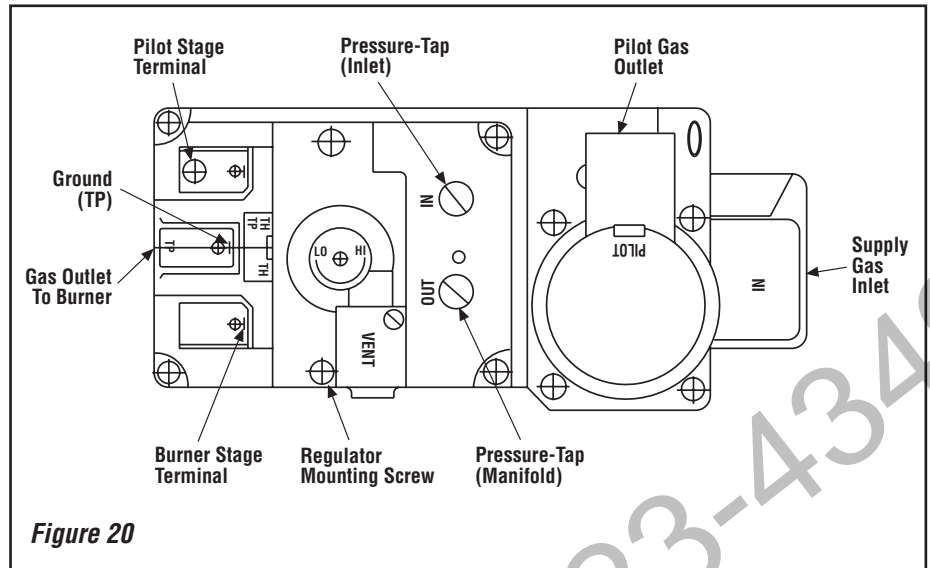
**Note:** Propane pilot orifices are identified with a countersink in the head. Natural gas orifices do not have this countersink. See **Figure 21**.

**Step 6.** (Refer to **Figure 19** on page 15 )

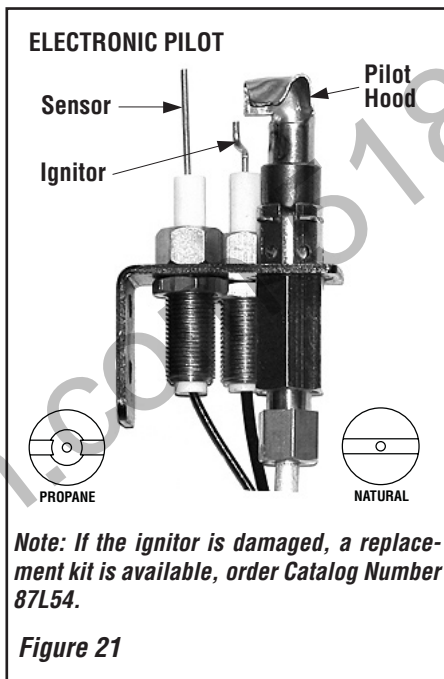
**A.** Remove the orifice from the manifold with a 1/2" deep throat socket. See the following table for orifice sizes for natural and propane models. **Figure 22** illustrates the orifice. Use pipe joint compound or Teflon tape on all pipe fittings before installing (ensure propane resistant compounds are used in propane applications, do not use pipe joint compounds on flare fittings).

**B.** Retrieve the burner and slide the venturi tube over the orifice. Secure the burner in place with the clip shown in **Figure 19**.

**Step 7.** Reassemble the remaining components by reversing the procedures outlined in the preceding steps.

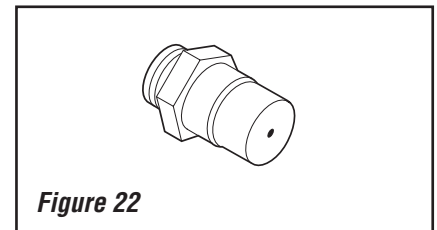


**Figure 20**



**Figure 21**

Model No.	Orifice size	
	Natural	Propane
E360DG	#28 (0.1405)	#47 (0.0785)
E420DG	#28 (0.1405)	#47 (0.0785)



**Figure 22**

NOTE: DIAGRAMS & ILLUSTRATIONS NOT TO SCALE.

Lennox Hearth Products reserves the right to make changes at any time, without notice, in design, materials, specifications, prices and also to discontinue colors, styles and products. Consult your local distributor for fireplace code information.

**LENNOX**<sup>TM</sup>

**HEARTH PRODUCTS**

1110 West Taft Avenue • Orange, CA 92865