

**INSTALLER/CONSUMER
SAFETY INFORMATION**

**PLEASE READ THIS MANUAL
BEFORE INSTALLING AND
USING APPLIANCE**

WARNING!
IF THE INFORMATION IN THIS
MANUAL IS NOT FOLLOWED
EXACTLY, A FIRE OR EXPLOSION
MAY RESULT CAUSING PROPER-
TY DAMAGE, PERSONAL INJURY
OR LOSS OF LIFE.

FOR YOUR SAFETY
Installation and service must
be performed by a qualified
installer, service agency or
the gas supplier.

- WHAT TO DO IF YOU SMELL GAS:**
- Do not try to light any appliance.
 - Do not touch any electric switch;
 - Do not use any phone in your building.
 - Immediately call your gas supplier from your neighbor's phone. Follow the gas suppliers instructions.
 - If you cannot reach your gas supplier call the fire department.

**DO NOT STORE OR USE
GASOLINE OR OTHER FLAM-
MABLE VAPORS AND LIQUIDS
IN THE VICINITY OF THIS OR
ANY OTHER APPLIANCE.**

MAJESTIC

VERMONT

Castings

Chateau™

**Direct Vent Decorative
Gas Appliance
Model: DVT38, DVT44**

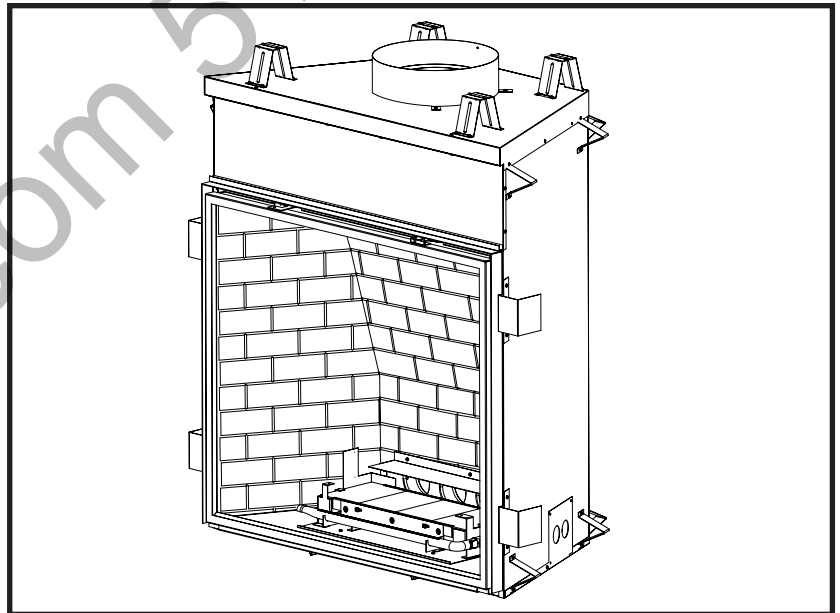

Installation Instructions and Homeowner's Manual

CFM Specialty Home Products

410 Admiral Blvd. • Mississauga, Ontario, Canada L5T 2N6 • 905-670-7777
www.majesticproducts.com • www.vermontcastings.com

INSTALLER: DO NOT DISCARD THIS MANUAL - LEAVE FOR HOMEOWNER

20006081 3/05 Rev. 7

Table of Contents

Please read the installation & operating instructions before using this appliance.

Thank you and congratulations on your purchase of a Vermont Castings, Majestic Products fireplace.

IMPORTANT: Read all instructions and warnings carefully before starting installation.

Failure to follow these instructions may result in a possible fire hazard and will void the warranty.

Installation & Operating Instructions

Important Curing/Burning Instructions	3
Locating Your Fireplace	3
Fireplace Dimensions	4
Clearance to Combustibles	5
Mantels	5
Hearth	5
Framing & Finishing	6
Final Finishing	7
Gas Specifications	7
Gas Inlet and Manifold Pressures	7
High Elevations	7
Gas Line Installation	7
Remote ON/OFF Switch	8
Electrical Junction Box	8
Electronic Gas Control Valve	8

General Venting Information

General Venting	9
General Venting Information - Termination Location	10
General Information Assembling Vent Pipes	11
SK8 Venting Pipes	11
Horizontal Termination	12
Vertical Termination	12
Sidewall Applications	12
Use of the Restrictor Plates in Horizontal Venting Applications	12
Sidewall Installation	14
Vertical Through-the-Roof Applications	15
Use of Restrictor Plates for Vertical Venting Applications	15
Vertical Through-the-Roof Installation	17
Chimney Components	19

Operating Instructions

Glass Information	20
Window Frame Assembly Removal	20
Glass Cleaning	20
Restrictor Plate Installation	20
Ceramic Refractory Installation	21
Log, Lava Rock and Ember Placement	22
Flame & Temperature Adjustment	24
Flame Characteristics	24
Lighting and Operating Instructions (Standing Pilot Models)	25
Lighting and Operating Instructions (Electronic Ignition Models)	26
Troubleshooting	27
Fuel Conversion	29

Maintenance

Cleaning the Standing Pilot Control System	32
Cleaning Electronic Ignition System	32
Battery Replacement for Ignitor Module	32

Replacement Parts

Optional Accessories

Warranty

Installation & Operating Instructions

This gas fireplace should be installed by a qualified installer in accordance with local building codes and with current CSA-B149.1 Installation codes for Gas Burning Appliances and Equipment. For USA Installations follow local codes and/or the current National Fuel Gas Code. ANSI Z223.1/NFPA 54.

FOR SAFE INSTALLATION AND OPERATION PLEASE NOTE THE FOLLOWING:

1. This fireplace gives off high temperatures and should be located out of high traffic areas and away from furniture and draperies.
2. Children and adults should be alerted to the hazards of the high surface temperatures of this fireplace and should stay away to avoid burns or ignition of clothing.
3. **CAUTION: Due to high glass surface temperature children should be carefully supervised when in the same room as fireplace.**
4. Under no circumstances should this fireplace be modified. Parts removed for servicing should be replaced prior to operating this fireplace again.
5. Installation and any repairs to this fireplace must be performed by a qualified installer, service agency or gas supplier. A professional service person should be contacted to inspect the fireplace annually. More frequent cleaning may be required due to excess lint and dust from carpeting, bedding material, etc.
6. Control compartments, burners and air passages in this fireplace should be kept clean and free of dust and lint. Make sure that the gas valve and pilot light are turned off before you attempt to clean this fireplace.
7. The venting system (chimney) of this fireplace should be checked at least once a year and if needed your venting system should be cleaned.
8. Keep the area around your fireplace clear of combustible materials, gasoline and other flammable vapor and liquids. This fireplace should not be used as a drying rack for clothing, nor should Christmas stockings or decorations be hung on or around the fireplace.
9. Under no circumstances should any solid fuels (wood, coal, paper or cardboard etc.) be used in this fireplace.
10. The flow of combustion and ventilation air must not be obstructed in any way.
11. When the fireplace is installed directly on carpeting, vinyl tile or any combustible material other than wood, this fireplace must be installed on a metal or wood panel extending the full width and depth of the fireplace.
12. This fireplace requires adequate ventilation and combustion air to operate properly.
13. This fireplace must not be connected to a chimney flue serving a separate solid fuel burning fireplace.
14. When the fireplace is not in use it is recommended that the gas control valve be left in the "OFF" position.

NOTE: This appliance uses a fast acting thermocouple and must be replaced with same.

Proposition 65 Warning: Fuels used in gas, woodburning or oil fired appliances, and the products of combustion of such fuels, contain chemicals known to the State of California to cause cancer, birth defects and other reproductive harm. California Health & Safety Code Sec. 25249.6

This appliance may be installed in an aftermarket permanently located, manufactured home or mobile home, where not prohibited by local codes.

This appliance is only for use with the type of gas indicated on the rating plate. This appliance is not convertible for use with other gases, unless a certified kit is used.

The DVT38/44 has been approved for mobile home installations.

IMPORTANT:

PLEASE REVIEW THE FOLLOWING CAREFULLY

Remove any plastic from parts before turning the fireplace ON.

It is normal for fireplaces fabricated of steel to give off some expansion and/or contraction noises during the start up or cool down cycle. Similar noises are found with your furnace heat exchanger or car engine.

It is not unusual for your Vermont Castings, Majestic Products gas fireplace to give off some odor the first time it is burned. This is due to the curing of the paint and any undetected oil from the manufacturing process.

Please ensure that your room is well ventilated-open all windows.

It is recommended that you burn your fireplace for at least ten (10) hours the first time you use it.

Locating Your Fireplace

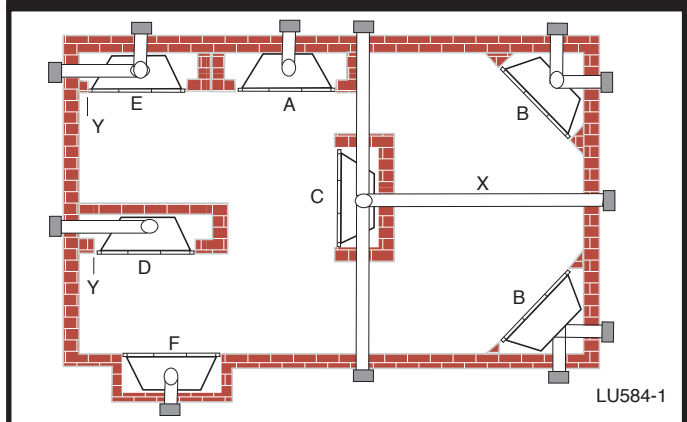

Fig. 1 Locate gas fireplace.

A) Flat on wall B) Cross corner C) **Island
D) *Room divider E) *Flat on wall corner F) Chase installation
Y) 6" minimum

Note (Fig. 1):

** Island (C) and Room Divider (D) installation is possible as long as the horizontal portion of the vent system (X) does not exceed 20' (6 m). See details in Venting Section.

* When you install your Vermont Castings, Majestic Products fireplace in (D) Room divider or (E) Flat on wall corner positions (Y), a minimum of 6" (152 mm) clearance must be maintained from the perpendicular wall and the front side edge of the fireplace.

Clearance to Combustibles

- Appliance
 Top Standoffs0" (0mm)
 Bottom0" (0mm)
 Side Standoffs0" (0mm)
 Back Standoffs0" (0mm)
- Venting
 Horizontal Termination through-a-side wall:
 Vertical Sections:
 Sides2½" (64mm)
- Horizontal Sections:
 Top3½" (89mm)
 Bottom1½" (38mm)
 Sides2½" (64mm)
- Vertical Vent Application:
 Sides1½" (38mm)

Mantels

The height that a combustible mantel is fitted above the fireplace is dependent on the depth of the mantel. This also applies to the distance between the mantel leg (if fitted) and the fireplace.

For the correct mounting height and widths refer to Figs. 4a and 4b, the following Mantel Charts.

Noncombustible mantels and legs may be installed at any height and width around the appliance.

When using paint or lacquer to finish the mantel, such paint or lacquer must be heat resistant to prevent discoloration.

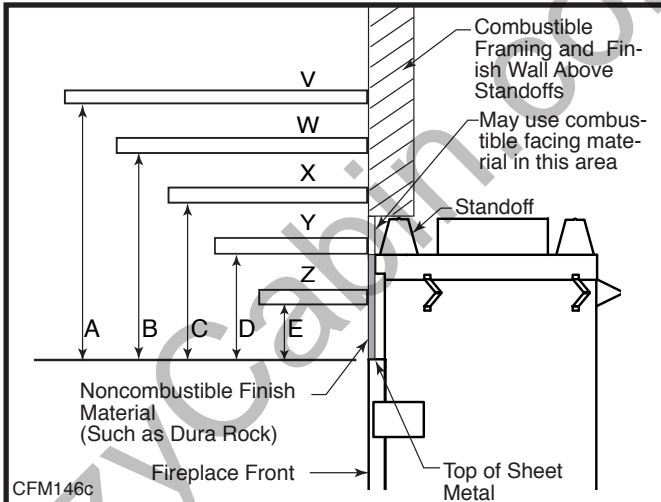

Mantel Chart			
Ref.	Mantel Shelf or Breast Plate Depth	Ref.	Mantel from Top of Comb. Chamber
V	10" (254 mm)	A	10" (254 mm)
W	9" (229 mm)	B	9" (229 mm)
X	8" (203 mm)	C	8" (203 mm)
Y	7" (178 mm)	D	7" (178 mm)
Z	6" (152 mm)	E	6" (152 mm)

Fig. 4a Combustible mantel minimum installation. 20006081

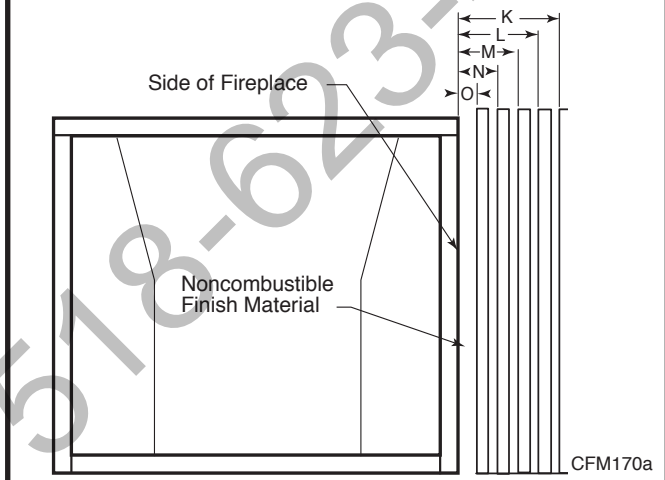
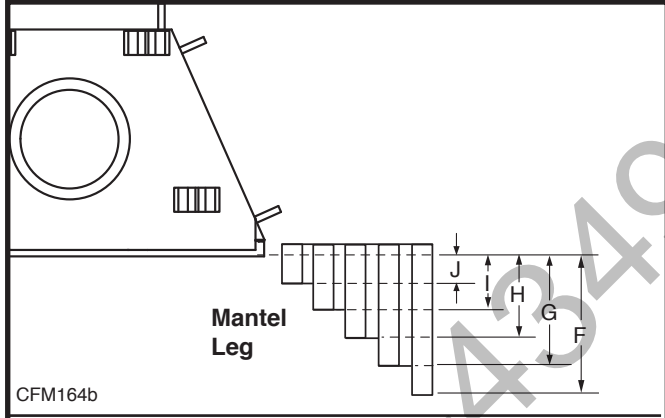

Ref.	Mantel Leg Depth	Ref.	Mantel Leg from Side of Comb. Opening
F	12" (305mm)	K	12" (305mm)
G	9" (229mm)	L	9" (229mm)
H	6" (152mm)	M	6" (152mm)
I	4" (102mm)	N	4" (102mm)
J	3" (76mm)	O	3" (76mm)

Fig. 4b Combustible mantel leg minimum installation.

Hearth

A hearth is not mandatory but is recommended for aesthetic purposes. We recommend a noncombustible hearth which projects out 12" (305mm) or more from the front of the fireplace. The hearth cannot exceed 1½" (38mm) in height from bottom of fireplace for ease of door accessibility. (Fig. 5)

Cold climate installation recommendation:
When installing this unit against a non-insulated exterior wall or chase, it is mandatory the outer walls be insulated to conform to applicable insulation codes.

Framing and Finishing

NOTE: The valve box assembly must be installed in the same room as the fireplace.

1. Choose the unit location.
2. The unit is shipped with four (4) nailing flanges mounted to the sides near the front corners. (Fig. 5)
3. Frame the fireplace with a header across the top of the standoff. (Fig. 6) It is very important to allow for the finished wall face along with marble, tiles or any

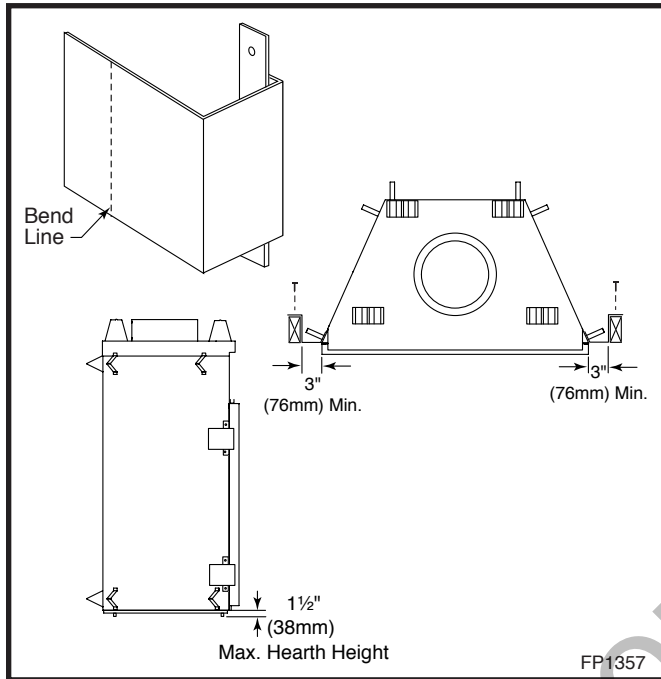

Fig. 5 Nailing flanges.

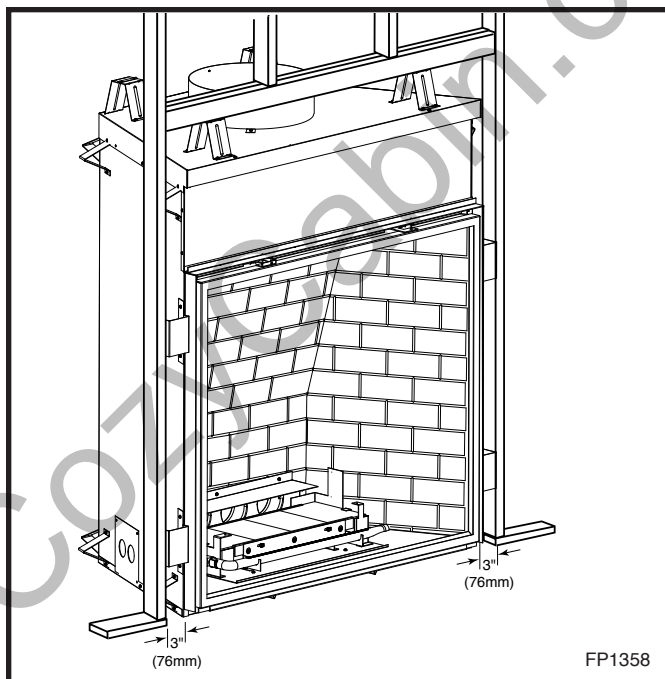

Fig. 6 Fireplace framing.

other noncombustible face finish material desired when setting the depth of the framing.

4. Attach the fireplace nailing flanges to the frame as shown in Figure 5.
5. The gas components are located in the control panel assembly attached to the right side of the unit. Choose the desired location on the wall or mantel for the valve box assembly. The conduit length is 5' (1524mm). (Fig. 7) The framing dimensions for the box are 12 1/4" L x 9 1/4" W x 5 5/8" D (311 mm x 235 mm x 143 mm). When the framing for the box is complete, remove the screws securing the valve box to the outer casing. Carefully remove the valve box and, without stressing the conduit, slide the box into the framed opening. Replace the screws removed from the side of the outer casing.

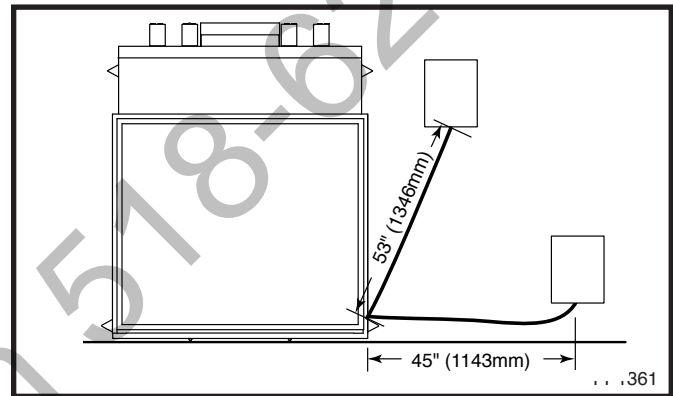

Fig. 7 Valve box assembly location.

6. To secure the valve box assembly to the framing members, open the box door, remove extension knob(s). For units with two piece cover plates, remove the front cover plate by removing the screws holding the front plate to the second plate. Disconnect the wires for the pilot indicator and remove the second plate located at the top of the box.

For units with a one piece cover plate, remove the valve cover by removing the two (2) screws securing the valve cover to the box, hold the cover plate with one hand and disconnect the wires to the switch and pilot indicator (R models only). **NOTE:** Do not allow the valve cover plate to hang from the pilot indicator wires as this could damage the wires.

Secure the box to the framing through the two (2) holes at the top and one (1) on each side using sheet rock screws. (Fig. 8) After framing the box, replace the wires, the valve cover, the extension knob(s) in reverse order.

NOTE: The pilot indicator body is labelled +/-, make sure the positive wire on the pilot indicator goes to ground and the negative goes to the plug between the valve and the thermocouple.

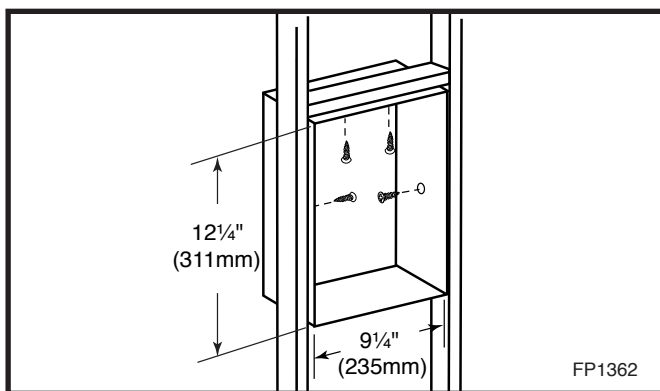

Fig. 8 Valve box framing.

7. The U-channel located on the top of the unit as well as the nailing flanges on the sides that were mentioned in Step 1, are designed to accommodate non-combustible board (recommended Dura-Rock). They are positioned 1" (25mm) back from the face of the unit. **NOTE:** The U-channel depth can be adjusted by loosening the hex nut inside the channel.

If marble, tile or any other noncombustible decorative face finish material is desired, a 3" (76mm) wide noncombustible board (recommended Dura-Rock) is to be nailed to the nailing flanges on both sides of the unit. Also, 12" (305mm) of noncombustible board is to be nailed to the front face of the U-channel and the top framing member above the standoff.

Combustible material can then be brought to the outside edges of the noncombustible board installed earlier. Any noncombustible decorative face finish could be brought to the sides and top of the unit and can cover the framing and sheet rock. If a decorative facing is not desired, then the noncombustible boards must be double thickness and brought flush with the face of the unit.

Final Finishing

Noncombustible materials such as brick or tile may be brought to the edges of the face of the appliance.

DVT38 / DVT44
Certified To
ANSI Z21.50b-2002/CSA 2.22b-2002
Vented Gas Fireplace

DVT38 Units: GF1HC0, GF1IC0, GF1AC0, GF1BC0

DVT44 Units: E21H00, E21I00, E21A00, E21B00

Gas Inlet and Manifold Pressures

	Natural	LP (Propane)
Minimum Inlet Pressure	5.5" w.c.	11.0" w.c.
Maximum Inlet Pressure	14.0" w.c.	14.0" w.c.
Manifold Pressure	3.5" w.c.	10.0" w.c.

Gas Specifications

MODEL	FUEL	GAS CONTROL	MAX. INPUT	MIN. INPUT
			B.T.U.H	B.T.U.H.
DVT38RN	Natural Gas	Millivolt	46,000	34,000
DVT38RP	Propane	Millivolt	46,000	36,000
DVT38EN	Natural Gas	24V Hi/Lo	46,000	34,000
DVT38EP	Propane	24V Hi/Lo	46,000	36,000
DVT44RN	Natural Gas	Millivolt	60,000	37,000
DVT44RP	Propane	Millivolt	60,000	45,000
DVT44EN	Natural Gas	24V Hi/Lo	60,000	37,000
DVT44EP	Propane	24V Hi/Lo	60,000	45,000

High Elevations

Input ratings are shown in BTU per hour and are certified without deration for elevations up to 4,500 feet (1,370m) above sea level.

For elevations above 4,500 feet (1,370m) in USA, installations must be in accordance with the current ANSI Z223.1/NFPA 54 and/or local codes having jurisdiction.

In Canada, please consult provincial and/or local authorities having jurisdiction for installations at elevations above 4,500 feet (1,370m).

WARNING: Improper installation, adjustment, alteration, service or maintenance can cause injury or property damage. Refer to this manual for correct installation and operational procedures. For assistance or additional information consult a qualified installer, service agency, or the gas supplier.

Gas Line Installation



When purging gas line the front glass must be removed.



A gas shut off valve must be installed on the gas pipe line going into the appliance within easy access.

The gas pipeline can be brought in through the bottom right side of the valve box assembly.

The gas line connection can be made with properly tinned 1/2" copper tubing or 1/2" gas tight. Some municipalities have additional local codes, it is always best to consult your local authority and the CSA-B149.1 installation codes.

For USA installations consult the current National Fuel Gas Code, ANSI Z223.1/NFPA 54.

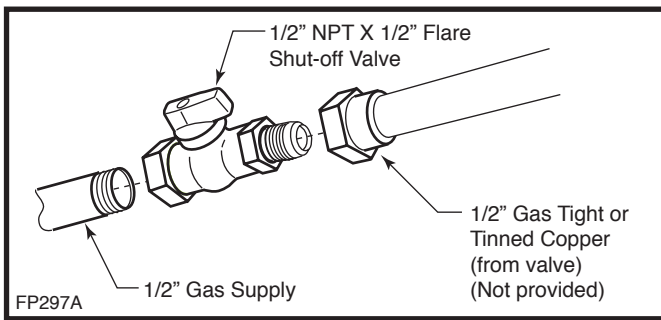

Fig. 9 Typical gas supply installation.

Always check for gas leaks with a mild soap and water solution applied with a brush no larger than 1" (25mm). Never apply soap and water solution with a spray bottle. Do not use an open flame for leak testing.

The fireplace valve must not be subjected to any test pressures exceeding 1/2 psi. Isolate or disconnect this or any other gas appliance control from the gas line when pressure testing.

The gas control is equipped with a captured screw type pressure test point, therefore it is not necessary to provide a 1/8" test point up stream of the control.

When using copper, use only approved fittings. **Always provide a union** when using black iron pipe so the gas line can be easily disconnected for burner servicing. A union may not be behind a wall. (Fig. 9) See the gas specifications for pressure details and ratings.

Remote ON/OFF Switch

Do not wire the remote ON/OFF wall switch for this gas appliance into a 120V power supply.

The unit is equipped with an ON/OFF rocker switch at the valve box assembly. If a wall switch is desired, follow these instructions.

1. The valve box is equipped with two knockouts at the top right and left corners. The right knockout is designed to run the wall switch wires to the valve. Use Romex connectors when running wires through the valve box where the knockouts are located.
2. Attach the wire to the ON/OFF switch and install the switch into the receptacle box.
3. Connect the other end of the wire to the gas control valve. (Fig. 10)

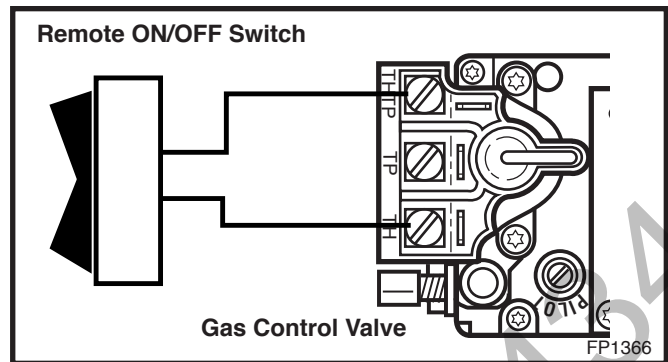

Fig. 10 Remote switch wiring diagram for R models.

Electrical Junction Box (E Units Only)

The fireplace, when installed, must be electrically connected and grounded in accordance with local codes or, in the absence of local codes, with the current CSA C22.1 Canadian Electrical Code or the national electrical code ANS/NFPA No. 70 in the USA.

It is strongly suggested that the wiring of the Electrical Junction Box be carried out by a licensed electrician. The box should be near the valve box assembly to plug the cord into.

Ensure the power to the supply line has been disconnected before commencing this procedure.

Electronic Gas Control Valve

This appliance may be fitted with a Honeywell ignition module. The unit is shipped from the manufacturer with an ON/OFF switch. The ON/OFF switch is located in the valve box assembly. If desired a wall switch may be used.

Installation of the remote ON/OFF switch on electronic ignition units:

1. The valve box is equipped with two knockouts at the top right and left corners. The right knockout is designed to run the wall switch wires to the valve. The left knockout is designed for wiring the electronic unit (E model) to 120v with proper grounding. Use Romex connectors when running wires through the valve box where the knockouts are located.
2. Attach the wire to the ON/OFF switch and install the switch into the receptacle box. (Fig. 11)
3. Connect the White wire from the wall switch to the Black wire from the transformer, using an approved wire nut or terminal. Connect the Black wire from the wall switch to the Black wire running from the #6 position of the ignition module, also using an approved wire nut or terminal.

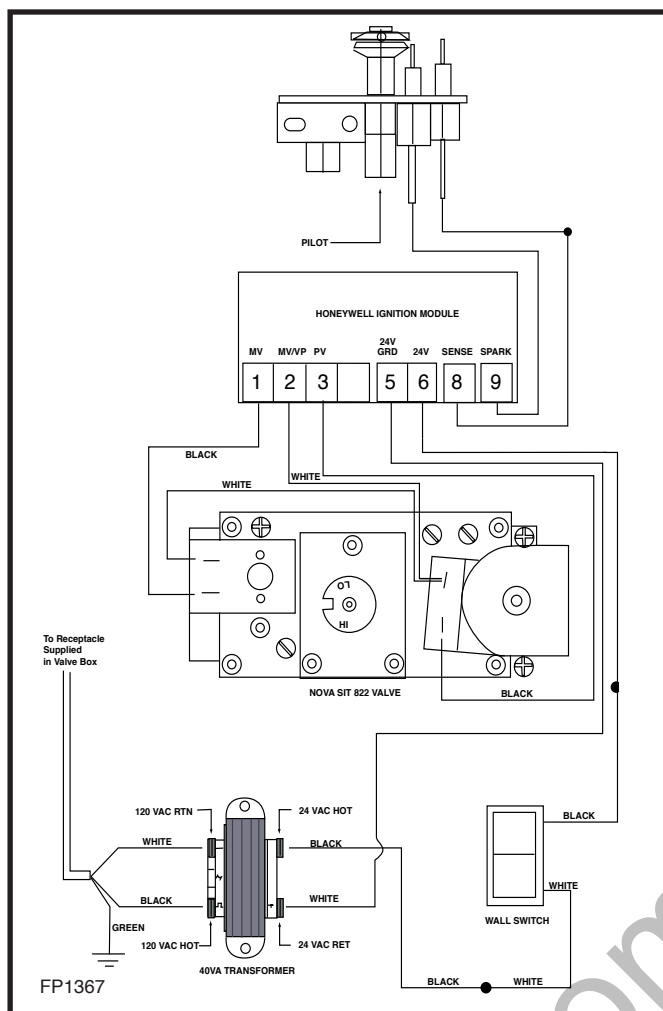

Fig. 11 Honeywell ignition module.

General Venting

Your fireplace is approved to be vented either through the side wall, or vertical through the roof.

- **Only Vermont Castings, Majestic Products venting components specifically approved and labelled for this fireplace may be used.**
- Venting terminals shall not be recessed into a wall or siding.
- Horizontal venting must be installed on a level plane without an inclining or declining slope.

There must not be any obstruction such as bushes, garden sheds, fences, decks or utility buildings within 24" (610mm) from the front of the termination hood.

Do not locate termination hood where excessive snow or ice build up may occur. Be sure to check vent termination area after snow falls, and clear to prevent accidental blockage of venting system. When using snow blowers, make sure snow is not directed towards vent termination area.

Location of Vent Termination

It is imperative the vent termination be located observing the minimum clearances as shown on following page.

General Venting Information - Termination Location

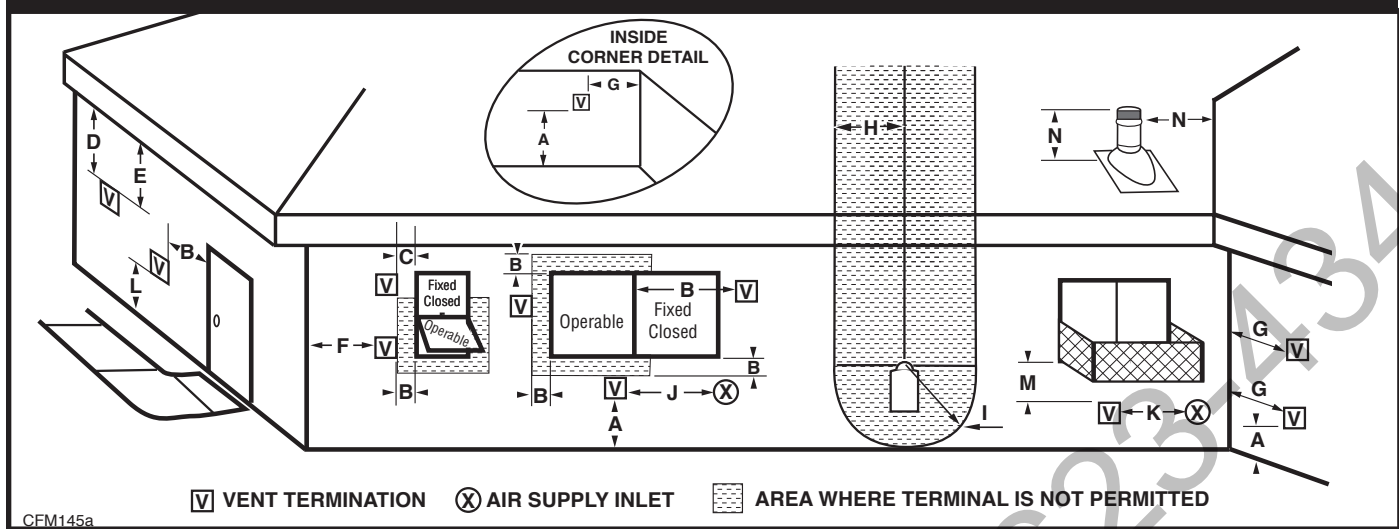

CFM145a

	Canadian Installations ¹	US Installations ²
A = Clearance above grade, veranda, porch, deck, or balcony	12" (30cm)	12" (30cm)
B = Clearance to window or door that may be opened	6" (15cm) for appliances < 10,000Btuh (3kW), 12" (30cm) for appliances > 10,000 Btuh (3kW) and < 100,000 Btuh (30kW), 36" (91cm) for appliances > 100,000 Btuh (30kW)	6" (15cm) for appliances < 10,000 Btuh (3kW), 9" (23cm) for appliances > 10,000 Btuh (3kW) and < 50,000 Btuh (15kW), 12" (30cm) for appliances > 50,000 Btuh (15kW)
C = Clearance to permanently closed window	12" (305mm) recommended to prevent window condensation	12" (305mm) recommended to prevent window condensation
D = Vertical clearance to ventilated soffit located above the terminal within a horizontal distance of 2 feet (610mm) from the center line of the terminal	18" (458mm)	18" (458mm)
E = Clearance to unventilated soffit	12" (305mm)	12" (305mm)
F = Clearance to outside corner	see next page	see next page
G = Clearance to inside corner (see next page)	see next page	see next page
H = Clearance to each inside of center line extended above meter/regulator assembly	3' (91cm) within a height of 15' above the meter/regulator assembly	3' (91cm) within a height of 15' above the meter/regulator assy
I = Clearance to service regulator vent outlet	3' (91cm)	3' (91cm)
J = Clearance to nonmechanical air supply inlet to building or the combustion air inlet to any other appliances	6" (15cm) for appliances < 10,000 Btuh (3kW), 12" (30cm) for appliances > 10,000 Btuh (3kW) and < 100,000 Btuh (30kW), 36" (91cm) for appliances > 100,000 Btuh (30kW)	6" (15cm) for appliances < 10,000 Btuh (3kW), 9" (23cm) for appliances > 10,000 Btuh (3kW) and < 50,000 Btuh (15kW), 12" (30cm) for appliances > 50,000 Btuh (15kW)
K = Clearance to a mechanical air supply inlet	6' (1.83m)	3' (91cm) above if within 10' (3m) horizontally
L = Clearance above paved sidewalk or paved driveway located on public property	7' (2.13m)†	7' (2.13m)†
M = Clearance under veranda, porch, deck or balcony	12" (30cm)‡	12" (30cm)‡
N = Clearance above a roof shall extend a minimum of 24" (610mm) above the highest point when it passes through the roof surface, and any other obstruction within a horizontal distance of 18" (450mm).		

¹ In accordance with the current CSA-B149 Installation Codes
² In accordance with the current ANSI Z223.1/NFPA 54 National Fuel Gas Codes
 † A vent shall not terminate directly above a sidewalk or paved driveway which is located between two single family dwellings and serves both dwellings
 ‡ only permitted if veranda, porch, deck or balcony is fully open on a minimum 2 sides beneath the floor:
 NOTE: 1. Local codes or regulations may require different clearances.
 2. The special venting system used on CFM Specialty Home Products Direct Vent Fireplaces are certified as part of the appliance, with clearances tested and approved by the listing agency.

Fig. 12 Vent termination clearances.

Termination Clearances

Termination clearances for buildings with combustible and noncombustible exteriors.

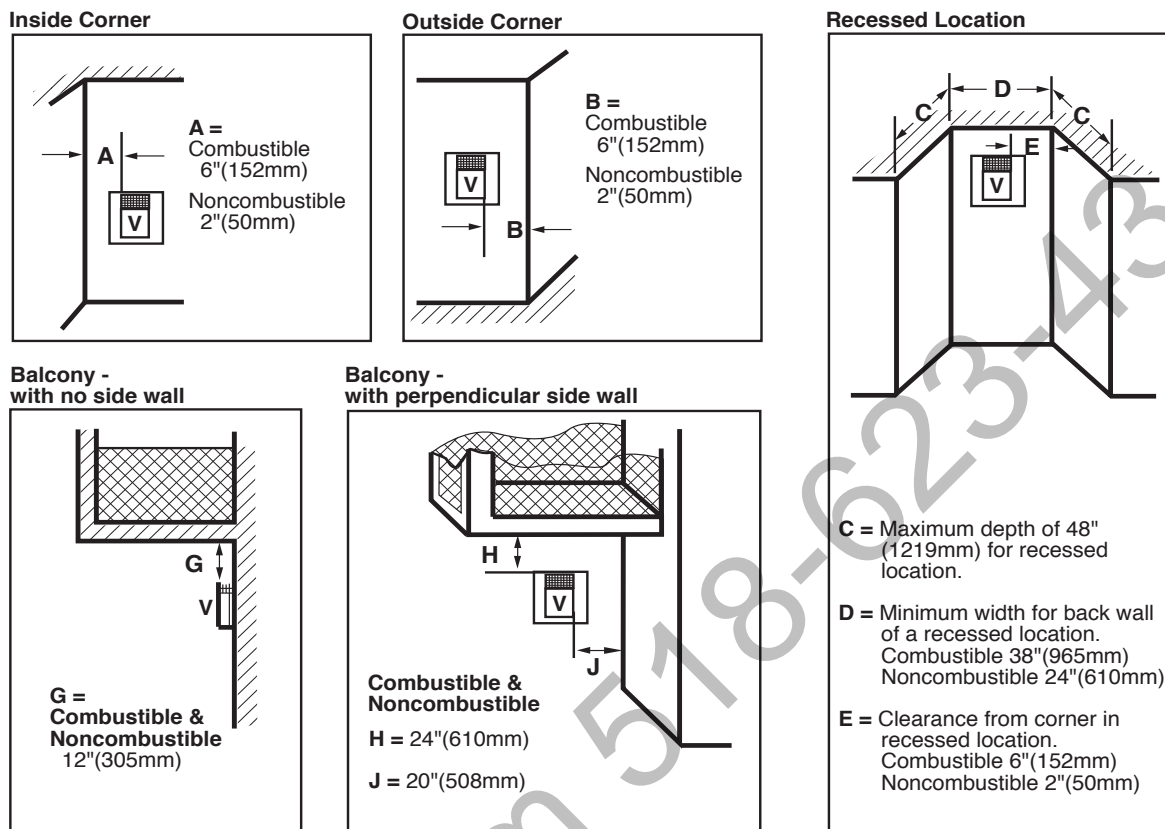

584-15

Fig. 13 Termination clearances.

Quick Reference for Fresh Air Restrictor Plate / Flue Baffle

Application	Item	DVT38N	DVT38P	DVT44N	DVT44P
SK8DVSK	Flue Restrictor Plate	3"	None	None	4½"
	Fresh Air Restrictor Plate	None	None	None	#1
Vertical Less than 12'	Flue Restrictor Plate	None	None	None	None
	Fresh Air Restrictor Plate	None	None	None	None
Vertical 12' to 20'	Flue Restrictor Plate	4½"	4½"	4½"	4½"
	Fresh Air Restrictor Plate	#3	#3	#3	#3
Vertical 20' to 30'	Flue Restrictor Plate	4½"	4½"	4½"	4½"
	Fresh Air Restrictor Plate	#2	#2	#2	#2
Vertical 30' to 40'	Flue Restrictor Plate	4½"	4½"	4½"	4½"
	Fresh Air Restrictor Plate	#1	#1	#1	#1

General Information Assembling Vent Pipes

SK8 Venting Pipes

Canadian Installations:

The venting system must be installed in accordance with the current CSA-B149 .1 installation code.

USA Installations:

The venting system must conform with local codes and/or the current National Fuel Gas code ANSI Z223.1/ NFPA 54.

Only venting components manufactured by Vermont Castings, Majestic Products can be used in Direct Vent systems.

NOTE: The joints of the inner pipe (flue pipe) must be taped with 550°F or higher temperature metal adhesive tape that meets the requirements of F.A.R. 25.853(a) High temperature sealant milpack or stove cement of 550°F or higher could be used instead. The joints of The outer pipe (fresh air pipe) must be taped with 315°F or higher temperature metal adhesive tape or the use of high temperature milpack or stove cement would be applicable. When using the unitized 30°, 45° or 90° elbows, apply 1/4" bead of high temperature, 550°F or higher, sealant (milpack or stove cement) to the joint of the inner pipe (flue pipe) and the straight section as it is impossible to be taped. The outer pipe must be taped with 315°F high temperature metal adhesive tape for proper sealing.

Start by attaching the first vent pipe section to the collar on top of the fireplace. In order to attach the first pipe section, it may be necessary to remove the top shield. Remove four (4) screws securing top shield, install first pipe section and replace top shield.

Install the pipe as shown in Figure 14. When you get a good lock, you will hear the pipe clearly snap together. Once sections are snap-locked in place, it is extremely difficult to get them apart. Make sure the pipe is firmly snapped and locked together as each pipe section is mounted.

When installing elbows, follow the same procedure. The joints of inner and outer elbow must be taped with UL approved high temperature metal adhesive tape for proper sealing. Be sure to always attach straps on upper elbow to a structural framing member.

For vertical installations, continue installing the pipe as required until pipe is installed up through the ceiling. At this point, you must install a firestop spacer.

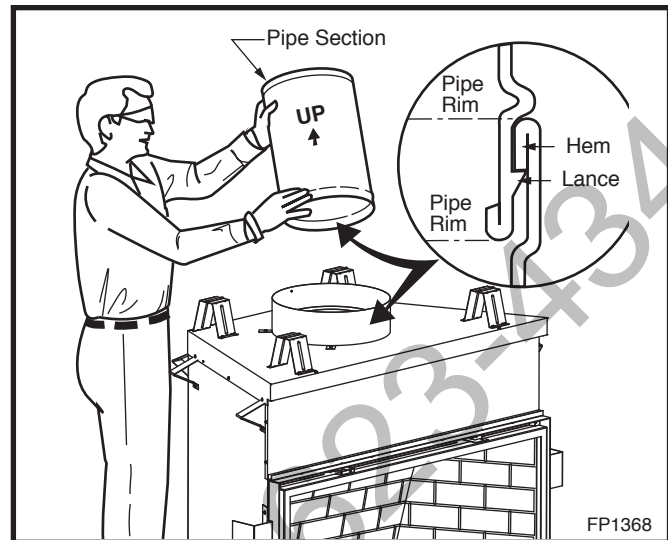

Fig. 14 Install pipe, listening for the snap-lock to fasten.

Horizontal Termination

The vent must rise vertically a minimum of 24" (610mm) off the top of the unit, before the first elbow. The horizontal run may extend up to 20' (6m) and include a vertical rise of up to 40' (12m). (Fig. 15) Horizontal termination must also meet the criteria shown in Figures 12 & 13.

- Approved vent systems must terminate above and including the heavy line in Figure 15.
- Two 45° elbows may be substituted for each single 90° elbow.
- With a rise between 2' - 4', one (1) 90° or two (2) 45° elbows may be used.

Vertical Termination

A vertical vent system must terminate no less than 12' (3.66m) and no more than 40' (12m) above the appliance flue collar. A 2' (610mm) vertical section must be installed before any offset. A maximum of 20' (6.1m) horizontal and three (3) 90° elbows may be installed with a minimum of 12' (3.66m) vertical section above the flue collar of the unit. Refer to Page 15, Figure 26 for more information.

A vertically terminated vent system must also conform to the following criteria:

- No more than three (3) 90° elbows may be used.
- Two (2) 45° elbows may be substituted for one (1) 90° elbow. No more than six (6) elbows may be used.

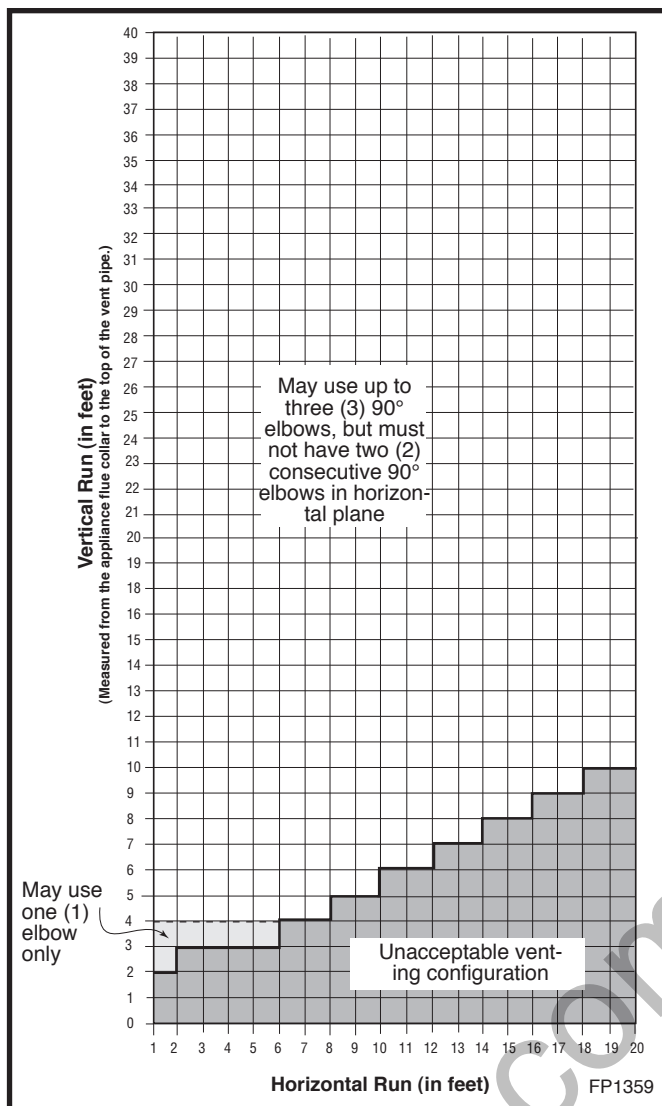

Fig. 15 Horizontal vent termination window.

- Vent must rise a minimum of 2' (610mm) before offset is used.
- Termination height must conform to roof clearance as specified in Figure 34.

Sidewall Applications



Since it is very important that the venting system maintain its balance between the combustion air intake and the flue gas exhaust, certain limitations as to vent configurations apply and must be strictly adhered to.

Use of the Restrictor Plates in Horizontal Venting Applications

The primary purpose for the vent restrictor plate is to regain flame height under certain venting conditions as outlined below.

DVT44 ONLY

When using the horizontal starter vent kit, SK8DVSK, with natural gas, do not use the restrictor plate. If using this vent kit with liquid propane, the 4½" restrictor plate may be used. (Fig. 16)

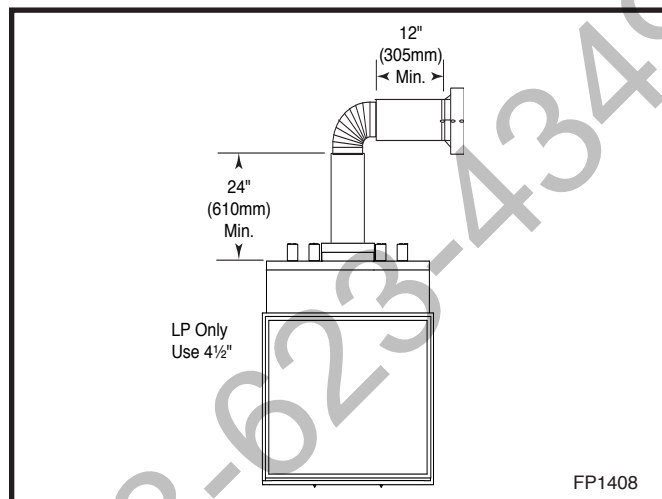

Fig. 16 Restrictor plate in horizontal venting.

For propane unit, fresh air restrictor plate is shipped from the factory at the #2 setting and can be adjusted to setting #1 in some applications if needed. Refer to Pages 20 & 21, Figures 36 & 38 for restrictor plate installation and fresh air plate setting adjustment.

DVT38 ONLY

When using the horizontal starter vent kit, SK8DVSK, with liquid propane, do not use the restrictor plate. If using this vent kit with natural gas, the 3" restrictor plate may be used. (Fig. 16)

The vent graph showing the relationship between vertical and horizontal side wall venting will help to determine the various dimensions allowable.



Minimum clearance between vent pipes and combustible materials is 3½" (89mm) on top, 2½" (64mm) on both sides and 1½" (38mm) on the bottom.

When the vent termination exits through foundations less than 20" (508mm) below siding outcrop, the vent pipe must be flush with the siding.

It is always best to locate the fireplace in such a way that minimizes the number of offsets and horizontal vent length of vent pipe from the flue collar of the fireplace to the face of the outer wall.

Horizontal plane means no vertical rise exists on this portion of the vent assembly.

- The maximum number of 90° elbows per side wall installation is three (3), but must not have two (2) consecutive elbows in the horizontal plane.

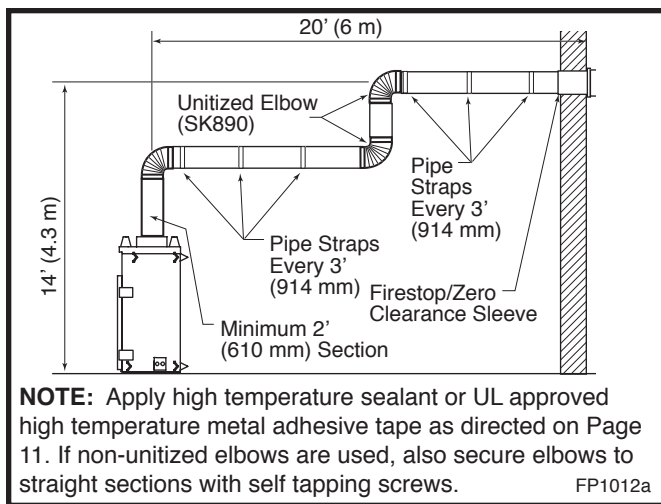

Fig. 17 Support straps for horizontal runs.

- A minimum of 2' (610mm) vertical section off the top of the unit is required, an elbow and a 1' (305mm) maximum horizontal run to get through a wall. (Fig. 18)
- The maximum number of 45° elbows permitted per side wall installation is two (2). These elbows can be installed in either the vertical or horizontal run. (Fig. 19)

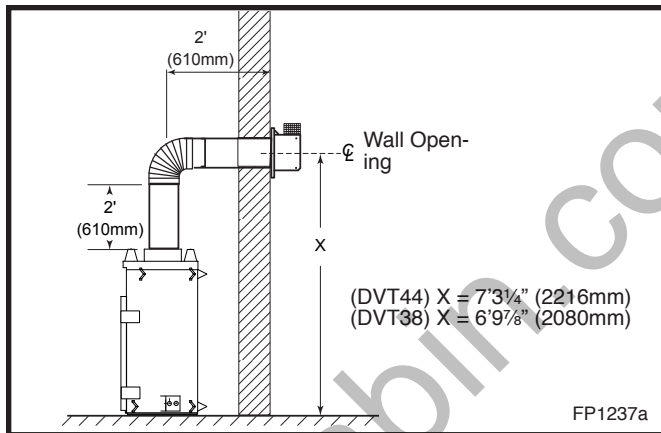

Fig. 18 Minimum vertical run / maximum horizontal run.

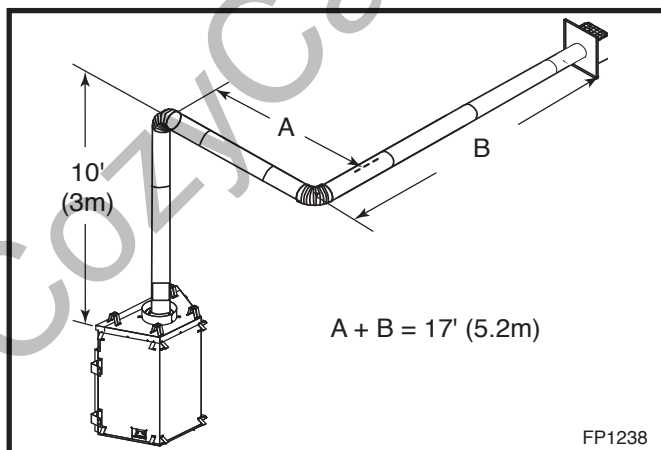

Fig. 19 Maximum vent run with elbows.

- For each 45° elbow installed in the horizontal run, the length of the horizontal run MUST be reduced by 18" (45cm). This does not apply if the 45° elbows are installed on the vertical part of the vent system. For each 90° elbow installed in the horizontal run, the length of the horizontal run MUST be reduced by 36" (91cm).
- The maximum number of elbow degrees in a system is 270°. (Fig. 20)

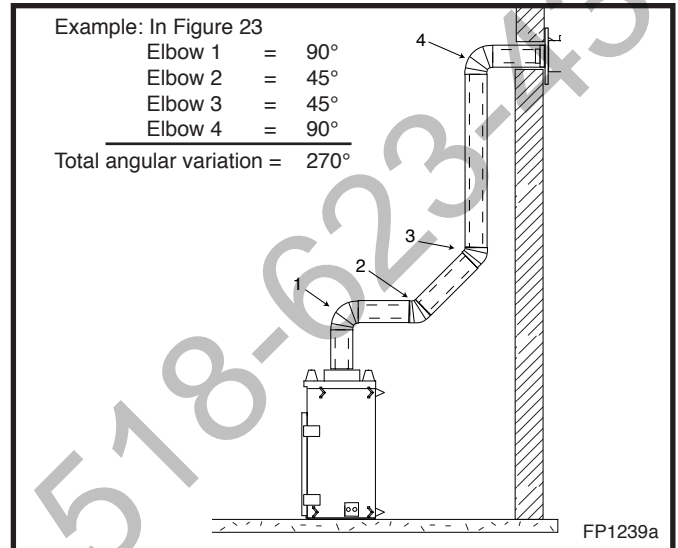

Fig. 20 Maximum number of elbow degrees.

Sidewall Installation

STEP 1

Locate vent opening on the wall. It may be necessary to first position the fireplace and measure to obtain hole location. Depending on whether the wall is combustible or noncombustible, cut opening to size. (Fig. 21)

For combustible walls first frame in opening.

Combustible Walls: Cut a 16¼"H x 16¼" W (413mm x 413mm) hole through the exterior wall and frame as shown.

Noncombustible Walls: Hole opening must be 11¼" (286mm) in diameter.

STEP 2

Measure wall thickness and cut zero clearance sleeve parts to proper length (MAXIMUM 12"/305 mm). Assemble sleeve using #8 sheet metal screws (supplied). (Fig. 22) Install firestop assembly. (Fig. 31)



Zero clearance sleeve is only required for combustible walls.

STEP 3

Slide the zero clearance sleeve through the wall and install the firestop on the inside surface of the wall. Secure with four (4) #8 sheet metal screws.

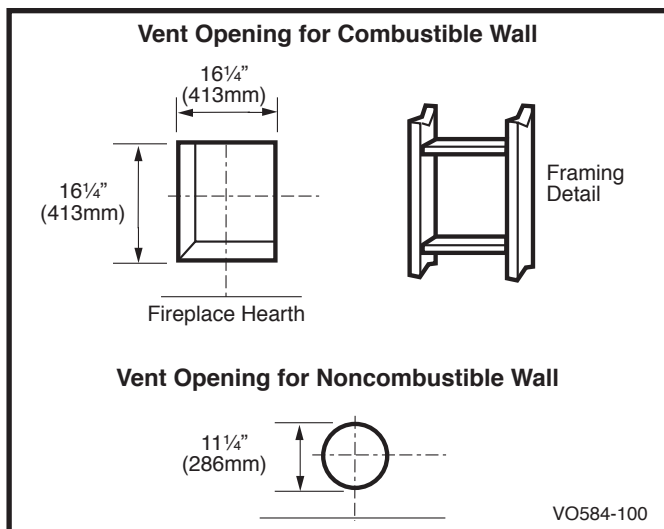

Fig. 21 Locate vent opening on wall.

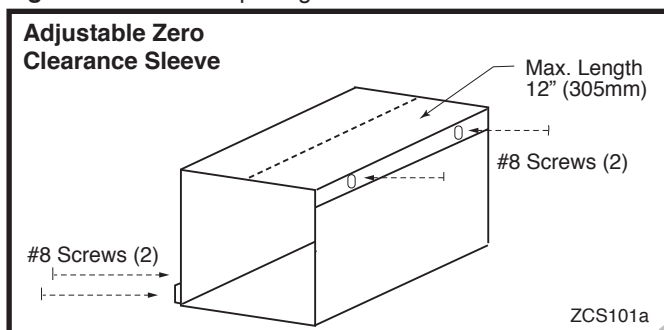

Fig. 22 Adjustable zero clearance sleeve.

STEP 4

Place fireplace into position. (Fig. 23) Measure the vertical height (X) required from the base of the flue collars to the center of the wall opening. **NOTE:** If using the SK8DVSK Kit, the vertical section of pipe is telescopic and could provide adjustment from 24" up to 40" (610mm to 1016mm).

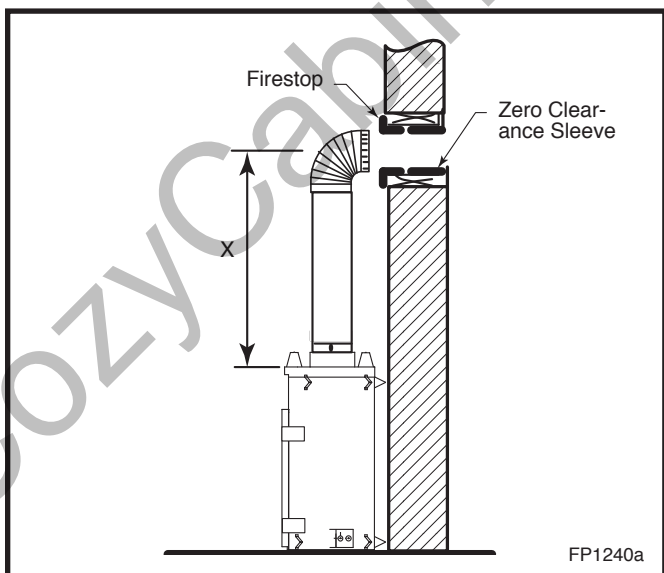

Fig. 23 Vertical height requirement.

STEP 5

Tap the inner and outer flue collars of the fireplace using UL approved metal adhesive tape to ensure the joints are sealed. Attach an appropriate length of vent pipe to the fireplace. Follow with the installation of the inner and outer elbow, tape elbow joints and secure joints as described on Page 11.

STEP 6

Measure the horizontal length requirement including a 2" (50mm) overlap, ie from the elbow to the outside wall face plus 2" (50mm) (or the distance required if installing a second 90° elbow). (Fig. 24)



Always install horizontal venting on a level plane.

STEP 7

Use appropriate length of pipe sections and install the horizontal vent sections. You may need to cut 1' wall section to size to be flush with the outside wall. The sections which go through the wall are packaged with the starter kit, and can be cut to suit if necessary. (Fig. 25)

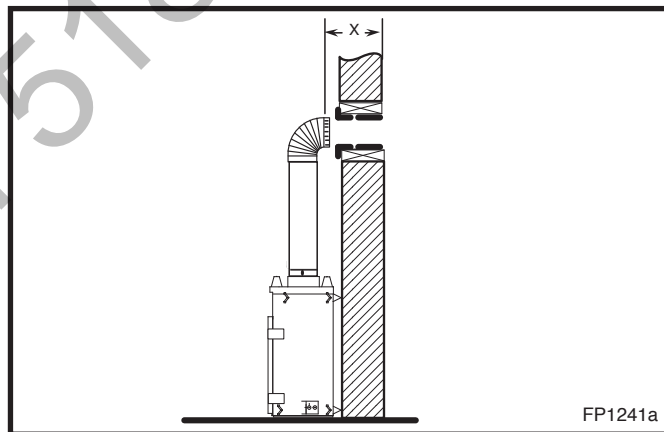

Fig. 24 Horizontal length requirement.

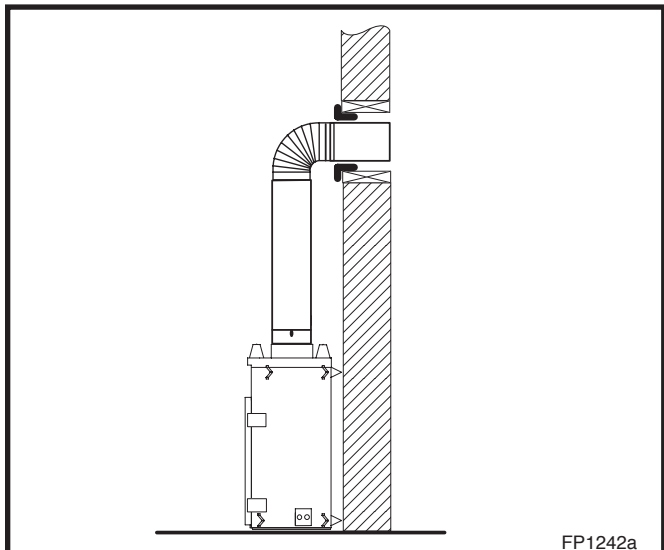



Fig. 25 Through the wall.

Sealing firestop gaps with high temperature sealant will restrict cold air being drawn in around fire-place.

STEP 8

Guide the vent terminations 8" and 11" collars into their respective vent pipes. Double check that the vent pipes overlap the collars by 2" (50mm). Secure the termination to the wall with screws provided and caulk around the wall plate to weatherproof. (Fig. 26) As an alternative to screwing the termination directly to the wall you may also use expanding plugs or an approved exterior construction adhesive.

-  **Support horizontal pipes every 3' (91 cm) with metal pipe straps.**
- Check fireplace to make sure it is levelled and properly positioned.**

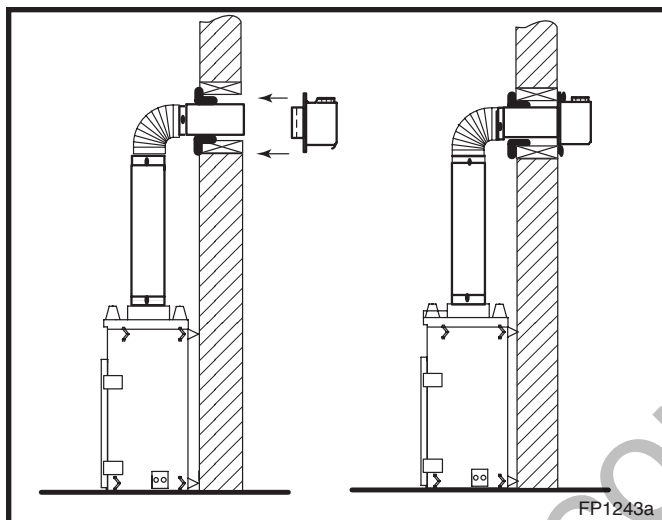

Fig. 26 Secure termination to wall.

Vertical Through-the-Roof Applications

Use of Restrictor Plate for Vertical Venting Applications

The primary purpose for the vent restrictor is to regain flame height under certain venting conditions as outlined below.

NOTE: The joints of the inner pipe (flue pipe) must be taped with 550°F or higher temperature metal adhesive tape that meets the requirements of F.A.R. 25.853(a) High temperature sealant milpack or stove cement of 550°F or higher could be used instead. The joints of The outer pipe (fresh air pipe) must be taped with 315°F or higher temperature metal adhesive tape or the use of high temperature milpack or stove cement would be applicable. When using the unitized 30°, 45° or 90° elbows, apply 1/4" bead of high temperature, 550°F or higher, sealant (milpack or stove cement) to the joint of the inner pipe (flue pipe) and the straight section as it is

impossible to be taped. The outer pipe must be taped with 315°F high temperature metal adhesive tape for proper sealing.

For vertically venting either propane or natural gas units, with vertical vent heights of 12' (3.7m) or greater, (measured from the top of the flue collar) the restrictor plate as supplied with this unit should be used. (Fig. 27) Also, the fresh air restrictor plate could be adjusted according to your vent height. (Fig. 27) Refer to Pages 20 & 21, Figures 36 & 38 for restrictor plate installation and fresh air restrictor plate adjustment.

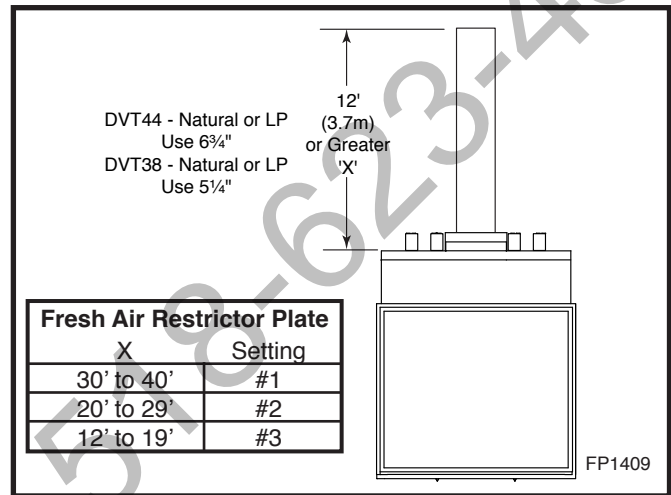

Fig. 27 Restrictor plate use in straight up installation.

For vertical venting configurations that include a minimum vertical rise of 12' (3.7m) and a maximum horizontal offset of 10' (3m) the 4 1/2" restrictor plate supplied with this unit should be used. The fresh air restrictor plate could be adjusted to the setting #3 (DVT44 Only). (Fig. 28) Refer to Pages 20 & 21, Figures 36 & 38 for restrictor plate installation and fresh air restrictor plate adjustment.

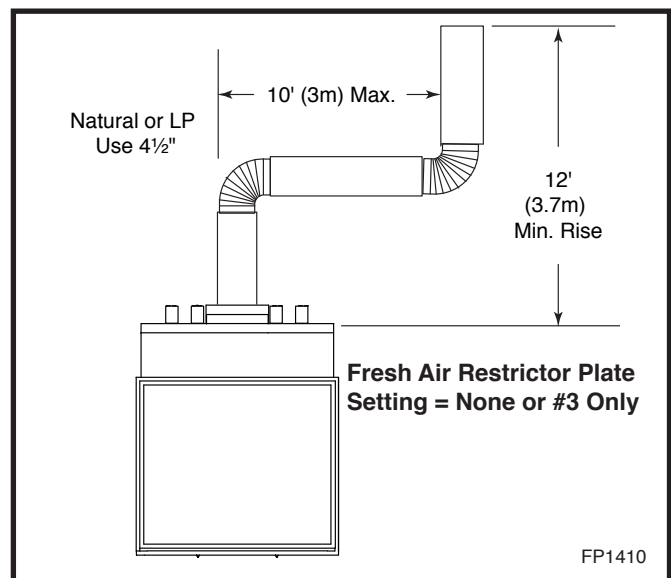

Fig. 28 Restrictor plate use with horizontal offset.

This Gas Fireplace has been approved for,

- Vertical installations up to 40' (12m) in height. Up to a 20' (6m) horizontal vent run can be installed within the vent system using a maximum of three (3) 90° elbows. (Fig. 29)
- A 2' (610mm) vertical section must be installed before any offset. A maximum of 20' (6.1m) horizontal and three (3) 90° elbows may be installed with a minimum of 12' (3.66m) vertical section above the flue collar of the unit. (Fig. 29)

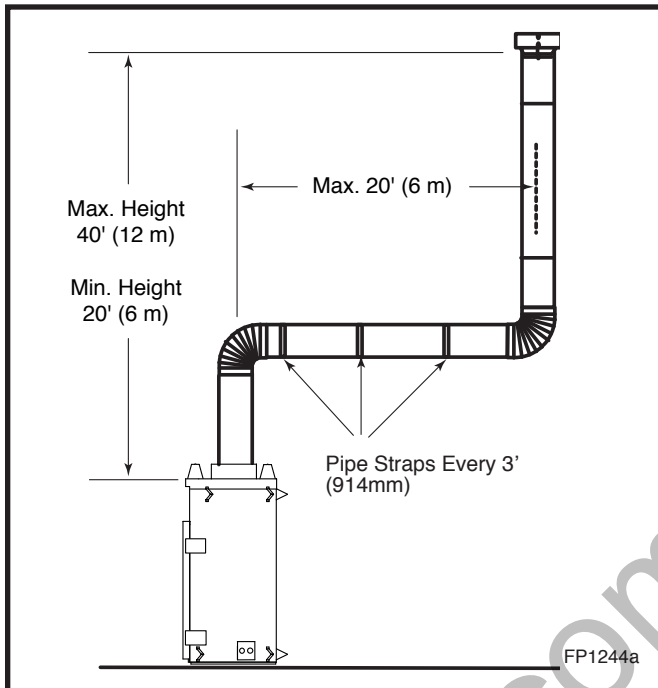

Fig. 29 Support straps for horizontal runs.

- Up to two (2) 30° or 45° elbows may be used within the horizontal run. For each 30° or 45° elbow used on the horizontal level the maximum horizontal length must be reduced by 18" (457mm).
Example: Maximum horizontal length
 - 0 x 30° or 45° elbows = 10' (3m)
 - 1 x 30° or 45° elbows = 8'6" (2.6m)
 - 2 x 30° or 45° elbows = 7' (2.1m)
- A minimum of an 12' (3.7m) vertical rise.
- Two sets of 30° or 45° elbows offsets within these vertical installations. From 0 to a maximum of 8' (2.4m) of vent pipe can be used between elbows. (Fig. 30)
- SKCS8 must be used to support offsets. (Fig. 31)
This application will require that you first determine the roof pitch and use the appropriate starter kit. (Refer to Venting Components List)
- The minimum height of the vent above the highest point of penetration through the roof is 2' (610mm). (Fig. 32)

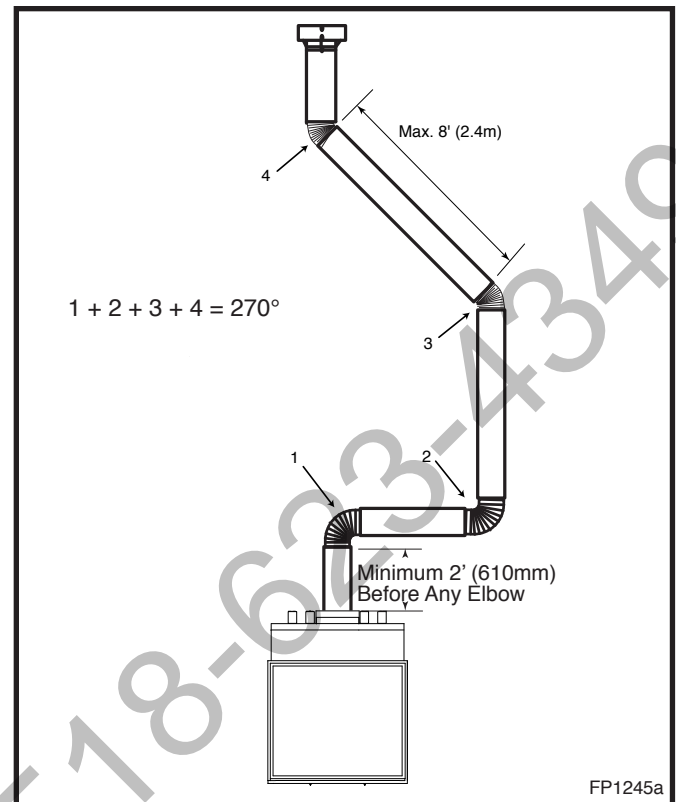

Fig. 30 Typical offset application.

Vertical Through-the-Roof Installation

1. Locate your fireplace.
2. Plumb to center of the (8") flue collar from ceiling above and mark position.
3. Cut opening equal to 14½" x 14½" (368mm x 368mm).
4. Proceed to plumb for additional openings through the roof. In all cases, the opening must provide a minimum of 1½" (38mm) clearance to the vent pipe, i.e., the hole must be at least 14½" x 14½" (368 mm x 368mm).
5. Place fireplace into position.
6. Place firestop(s) SKFS2A or Attic Insulation Shield AIS-SK into position and secure. (Figs. 31, 32)
7. Install roof support (Fig. 33) and roof flashing making sure upper flange of flashing is below the shingles.
8. Install appropriate pipe sections until the venting is above the flashing.
9. Seal around the pipe.
10. Add additional vent lengths for proper height. (Fig. 34)

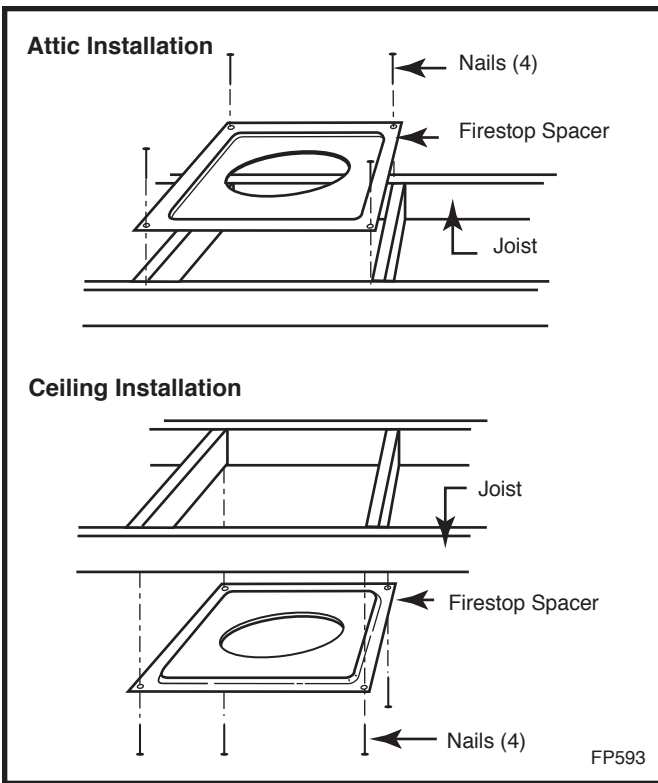

Fig. 31 Installing firestop spacer.

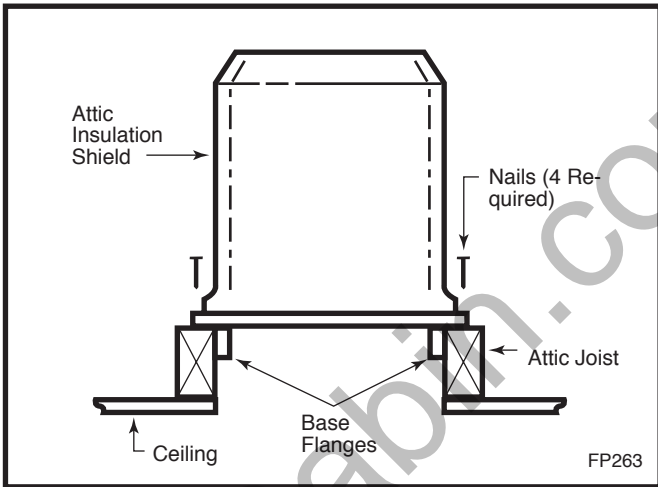

Fig. 32 Attic shield installation.

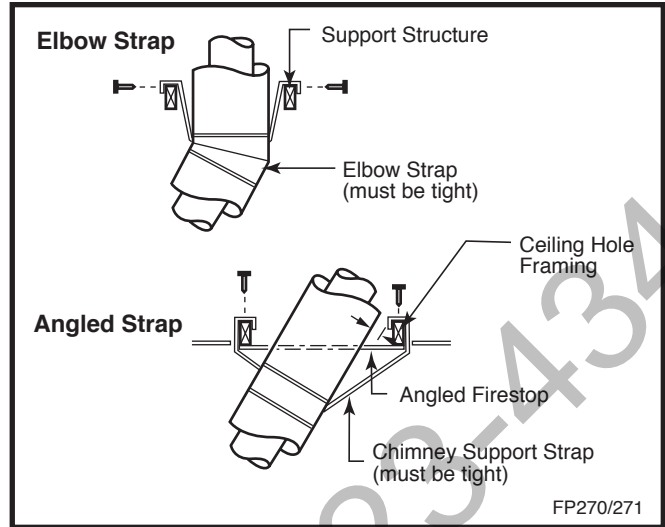

Fig. 33 Attach straps to a structural framing member.

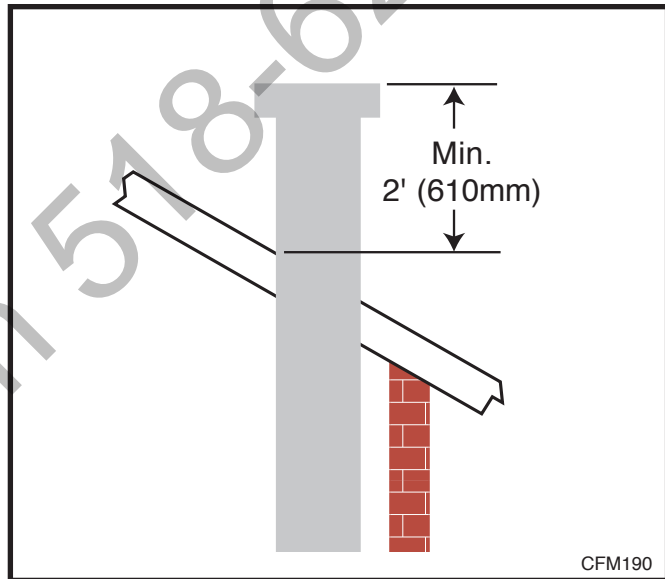

Fig. 34 Minimum termination to roof clearance.



If an attic is above ceiling level an AIS-SK (Attic Insulation Shield) must be installed. The enlarged ends of the vent section always face downward.

Chimney Components

Component	Description	Model Number
Horizontal Starter Kit	Contains 24"-40" telescopic pipe* for minimum vertical rise from collar pipe, 90° elbow, horizontal through-wall starter pipe, zero clearance sleeve, metal adhesive tape, sidewall termination and firestop.	SK8DVSK
SK8 Chimney Sections	Pipe used to build 8" (SK8) flue systems.	SK81 (1' Long) SK818 (12x' Long) SK83 (3' Long) SK84 (4' Long)
SK8 Chimney Elbows	Elbow used to create an offset in an 8" chimney system.	SK830-2 30° Elbow* (2 per pkg.) SK845 45° Elbow* SK890 90° Elbow*
Firestop	Required at each floor level of chimney installation. (Plus attic on multi-story installation.)	SKFS2A — (8" straight flue) SK8DVFS (Horizontal Firestop)
Zero Clearance Sleeve	Used when horizontal pipe goes through an interior vertical wall.	SK8ZCS
Attic Insulation Shield	Used to prevent insulation from coming in contact with the chimney system.	AIS-SK
Chimney Support	Used to support chimney for each of: 30' vertical height and 6' of angled chimney run.	SKCS8
Round Top Termination	Top used to terminate chimney at roof. (Flashing not included.)	RLTSK8
Round Top Termination - Extended	Top used to terminate chimney at chase. (Flashing not included.)	RLTSK8L
Flashing	Metal finishing required around termination to prevent rain leakage.	8-6-12 with 8" flue: 0-6/12 pitch 8-12-12 with 8" flue: 6/12-12/12 pitch
Housing Extensions	Extends Square Termination on steep pitched roofs.	202036
Chase Top Housing	Low profile pyramid-style chimney cap used to terminate chimney through a chase. Includes adapter. (Flashing not included.)	PTLSK8
Chase Top Housing	Square chimney cap used to terminate chimney through a chase. Terra Cotta Masonry. Includes adapter. (Flashing not included.)	SLTSK8
Horizontal Termination	Cap used to terminate venting through a sidewall.	SK8DVRVT

NOTE: The 24"-40" telescopic pipe is only intended for use with the SK8DVSK.

* Factory unitized elbow

Operating Instructions

Glass Information



Only glass approved by CFM Specialty Home Products should be used on this fireplace.

- The use of any non-approved replacement glass will void all product warranties.
- Care must be taken to avoid breakage of the glass.
- **Do not operate appliance with glass front removed, cracked or broken.**
- **A replacement glass frame assembly (complete with gasket) is available through your Vermont Castings, Majestic Products dealer and should only be installed by a licensed qualified service person.**

Glass Frame Assembly Removal

1. Turn the fireplace OFF (including the pilot).
2. If the unit has been operating allow time for the components to cool.
3. Using a Phillips screwdriver, unfasten two (2) screws located at the top of the glass frame. (Fig. 35)
4. Tilt the glass frame at the top away from the unit. Lift it carefully off the bottom door track and set on padded surface.

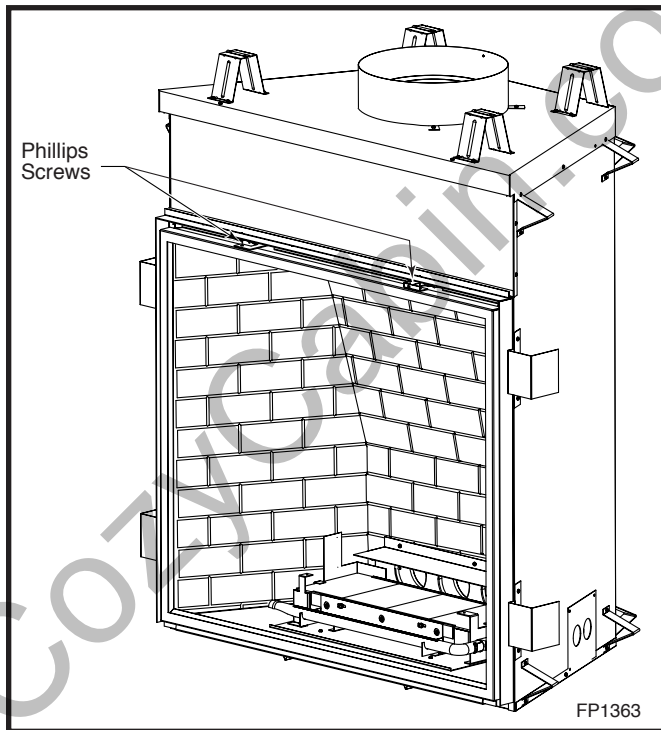

Fig. 35 Remove Phillips screws, tilt frame forward and lift off bottom door track.

Glass Cleaning

It is necessary to periodically clean the glass. During start-up, condensation, which is normal, forms on the inside of the glass. This condensation causes lint, dust and other airborne particles to cling to the glass surface.

Also initial paint curing may deposit a slight film on the glass. It is therefore recommended the glass be cleaned two or three times with a non-ammonia based household cleaner and warm water (gas fireplace glass cleaner is recommended) within the first few weeks of operation.

After the initial cleaning process the glass should be cleaned two or three times during each operating season depending on the environment in the house.



Clean the glass after the first two weeks of operation.

Restrictor Plates Installation

Refer to Pages 13 & 16 for your venting configuration and combination of restrictor plate requirement and fresh air restrictor plate adjustment.

Restrictor Plate Installation

Using the two (2) screws provided along with the restrictor plate shipped with the logset, fasten the restrictor plate to the firebox top through the front of the unit. (Fig. 36)

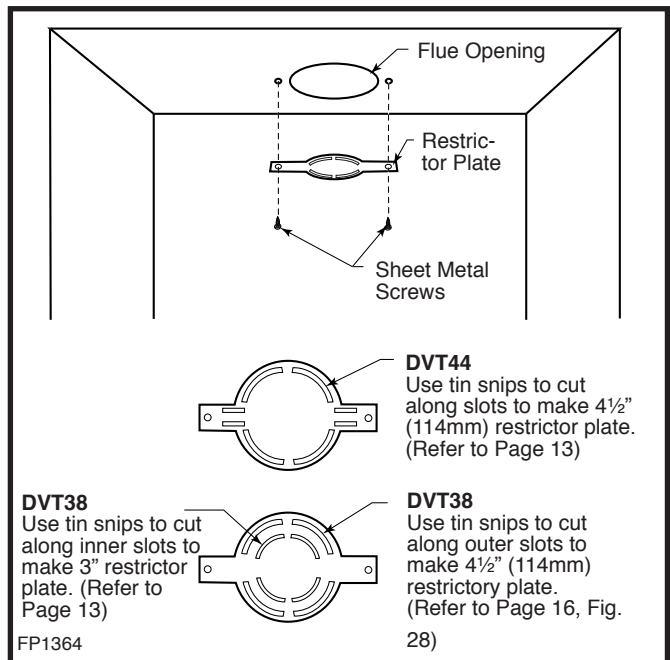

Fig. 36 Restrictor plate location.

Fresh Air Restrictor Plate Adjustment

1. Remove the glass.
2. Remove the logs, andirons and fettle.
3. Remove one side refractory (right or left) and remove the rear upper and lower refractory in reverse order of installation. (Refer to “Ceramic Refractory Installation” section.)
4. Remove the rear log bracket by removing three (3) screws. On some models you may be able to loosen the screws and slide bracket to the left and out. (Fig. 37)

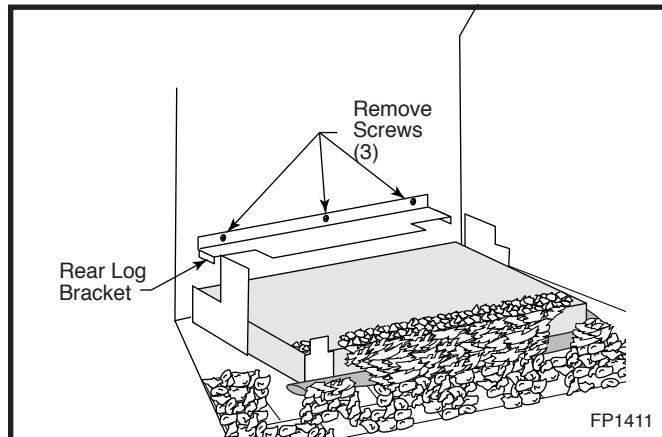

Fig. 37 Remove rear log bracket.

5. Adjust the fresh air restrictor plate setting. (Fig. 38) Simultaneously install the plate and the log bracket using the three (3) screws loosened or removed earlier. The adjustment is made by matching the proper setting on the plate with the three (3) holes on the firebox back.
6. Replace the rear lower and upper refractory, side refractory, fettle, andiron, logs and glass.

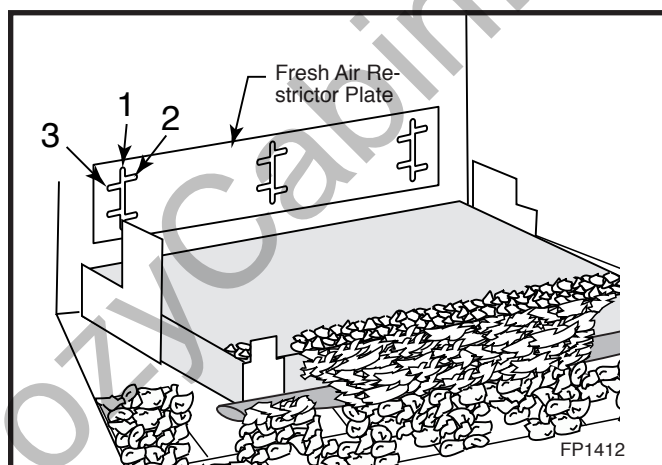

Fig. 38 Fresh air restrictor plate adjustment.

Ceramic Refractory Installation



The ceramic refractories are fragile and should be handled with care. Due to the size of the refractories, an assistant may be helpful.

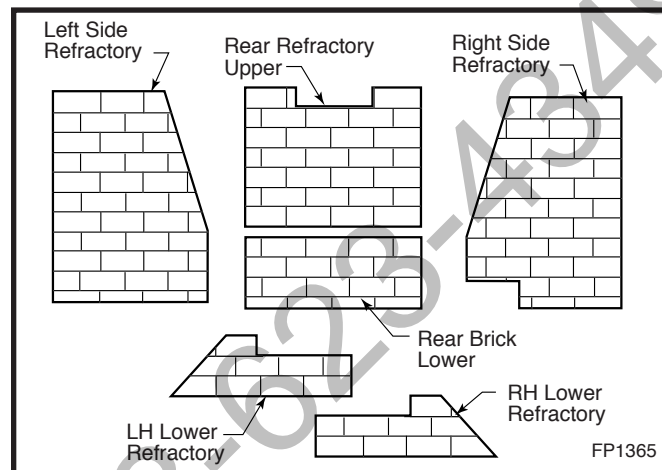

Fig. 39 DVT44 ceramic refractory panels.

1. Using a Phillips or Robertson screwdriver, unfasten the two (2) screws holding the fettle to the burner assembly. (Fig. 39) With a wrench, remove the front burner tube by unfastening the two (2) nuts that secure the burner tube to the front of the burner assembly.
2. Using a Phillips or Robertson screwdriver, remove the heat shield located toward the front top of the fire box by unfastening the five (5) screws that secure the heat shield in place. (Fig. 40)

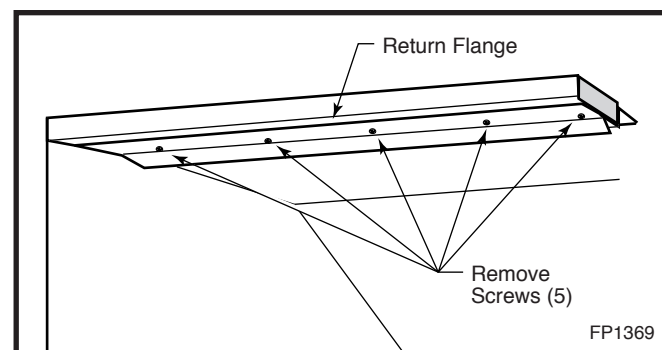

Fig. 40 Remove five (5) screws securing heat shield in place.

3. Start with either the right side refractory or left side refractory. Hold the refractory at an angle. Slide and seat the bottom edge toward the bottom of the firebox. Tilt it carefully toward the side until the piece is in place. Slide the refractory forward until it comes in contact with the front flange on the firebox.

4. Holding the rear refractory lower straight up, rotate it back behind the side refractory and set it on the small return bend of the rear log bracket toward the back of the firebox. Ensure the mortar lines in the refractory match the side refractory already installed.
5. Rotate back and set on the rear log bracket toward the back of the firebox.
6. The rear refractory upper has a notch in the top side. Holding the refractory at an angle, slide the refractory behind the side refractory installed.
7. While holding the rear refractory upper in place, follow Step 3 and install the remaining side refractory.
8. Adjust all refractory pieces so mortar lines are aligned. Replace heat shield removed in Step 2. Make sure the angle on the heat shield goes back. This will secure the side refractory in place.
9. Slide the right and left lower refractories into place in front of the burner and align.
10. Reinstall the burner tube and fettle.

Log, Lava Rock and Ember Placement

Unpack the logs from packaging and remove each log from its wrapping material.



The logs are fragile and should be handled with care. Keep the packaging materials out of the reach of children and dispose of the material in a safe manner.

1. Ensure the two (2) screws that attach the fettle to the burner are secure.
2. Set the andirons in place by hooking the tabs on the back of the andirons over the outermost webs of the fettle. (Fig. 41)
3. Place the volcanic rock over the lower refractory in front of the burner tube and around the burner assembly as desired. (Fig. 42)

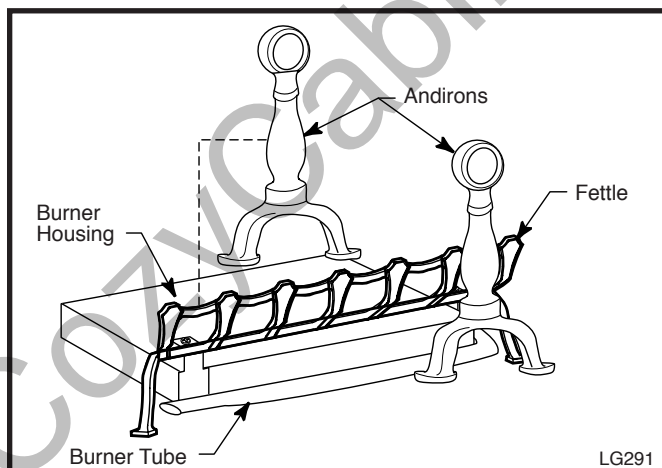

Fig. 41 Ensure fettle is securely attached to the burner housing and set andirons in place.

4. Place the ember material lightly in front over the burner tube. Cover the area between the burner tube and the burner pan assembly. (Fig. 43)
5. Place the small lava rock 1½" (38mm) along the top front edge of the burner pan assembly.

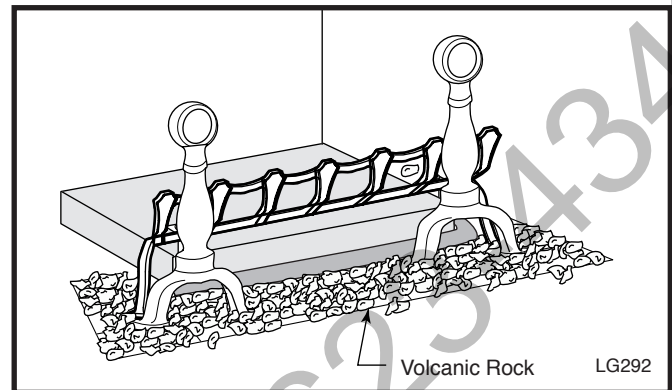

Fig. 42 Place volcanic rock on lower refractory in front of burner housing.

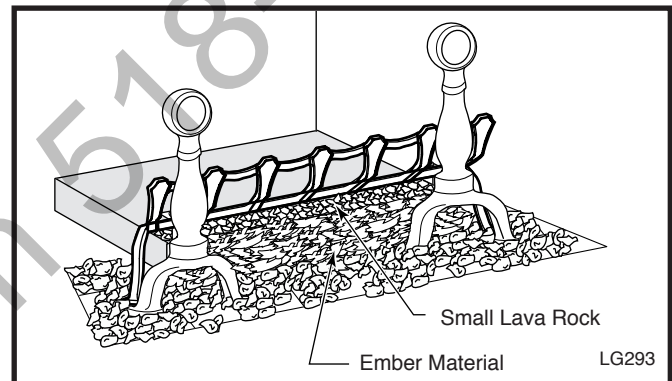

Fig. 43 Place ember material on burner tube. Place small lava rock 1½" on burner housing.

Refer to Figures 47 & 48 for final log positions.

6. Center the log rear onto the rear log bracket and slide back until it comes in contact with the rear refractory lower. (Fig. 44)
7. Hold the log front left with the narrower end toward the right. For DVT44, set the log on the inside left side of the fettle and bring it forward until the right end of the log comes through the opening in the fettle. For the DVT38, the log is placed the same, however the end will not come through the fettle. When in place, the left end of the log is supported above the left sheet metal bracket. DVT38, the log will just touch the left side refractory. (Fig. 45)
8. Hold the log right front with the pointed end toward the left. Set the log on the inside right side of the fettle and bring forward. The pointed end of the log should come in contact with the front left log. When in place, the right end of the log is supported above the sheet metal bracket toward the right. (Fig. 45)

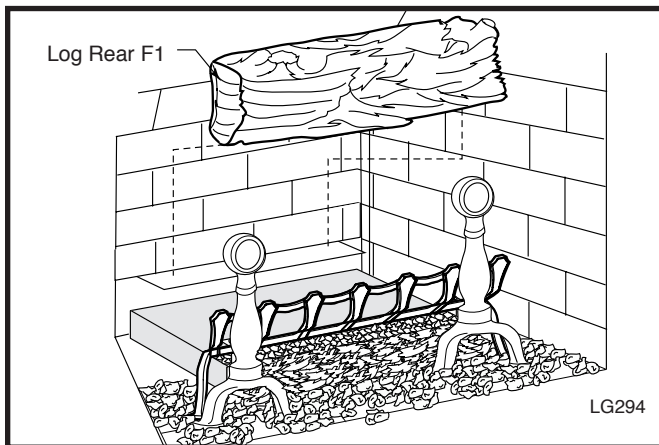

Fig. 44 Place log rear onto rear log bracket.

9. Hold the log top right front to back with the narrower end toward the back. With your left hand, tilt the front left log slightly up and forward. With your right hand position the fat end of the top right log on the small shelf on the back of the front right log. Lower the two logs in place until the narrower end of the top right log comes in contact and rests on the top right side of the rear log. (Fig. 46)

10. Hold the log top left at an angle with the burned area toward the middle. Set the top left log above the front left log, matching the indentation on the bottom of the top left log with the protrusion on the front left log. Lay the back end of the top left log onto the rear log. (Fig. 46)

11. Hold the log top middle at an angle with the curve of the log going from right to left. Position the front end of the top middle log over the right front log, matching the protrusion on the right front log with the indentation on the bottom of the top middle log. Lay the back end of the middle log onto the rear log and swing the end of the log from right to left until the end of the top middle log comes in contact with the top left log. (Fig. 46)

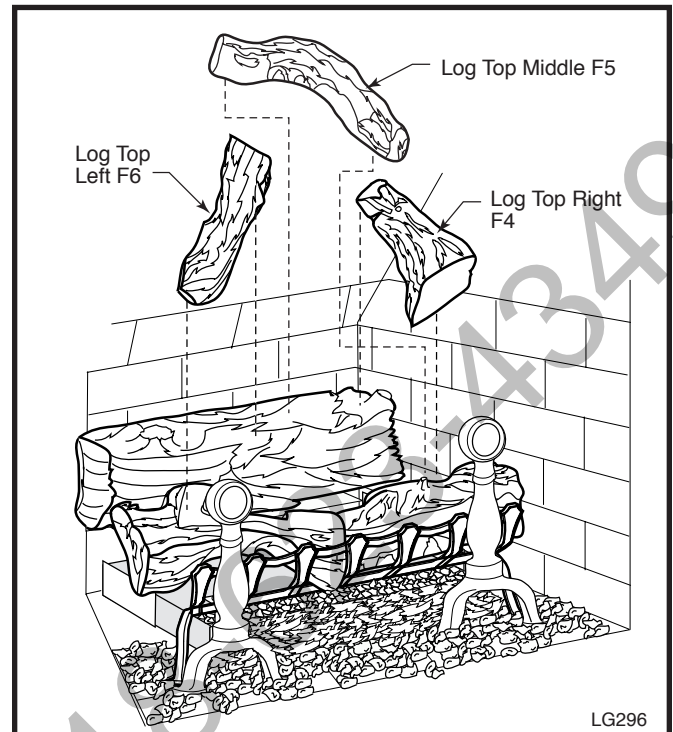

Fig. 46 Place middle logs.

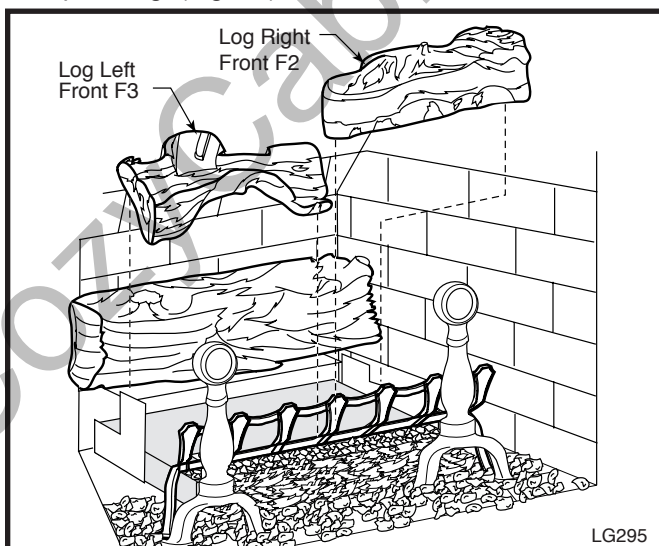

Fig. 45 Place logs left front and right front.

20006081

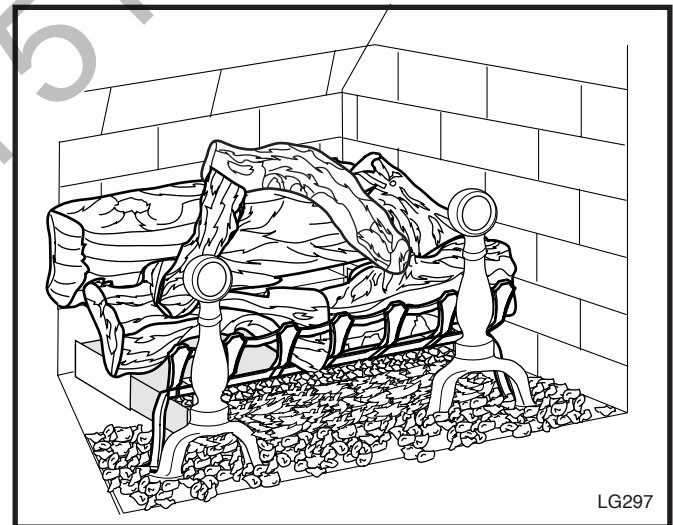

Fig. 47 DVT44 logset.

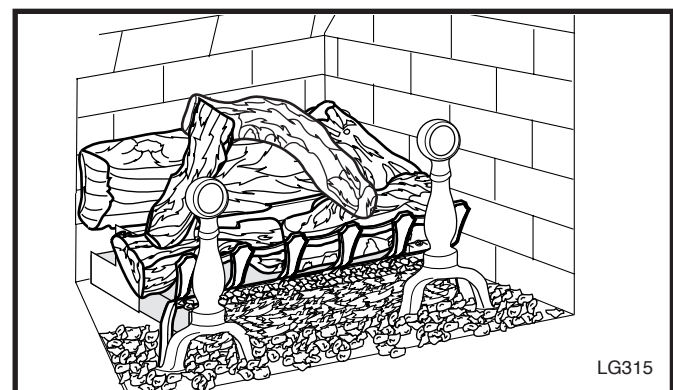

Fig. 48 DVT38 logset.

Flame & Temperature Adjustment

RN/RP & EN/EP Models

For units equipped with 'HI/LO' valves the flame adjustment is accomplished by rotating the 'HI/LO' adjustment knob located near the center of the gas control valve. (Fig. 49)

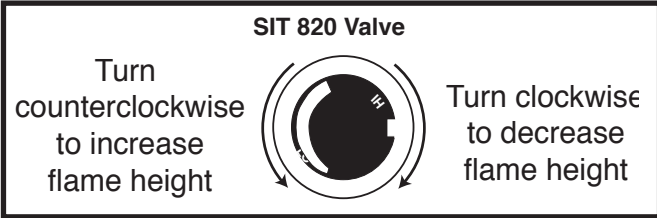

Fig. 49 Flame adjustment knob for SIT valve.

Flame Characteristics

It is important to periodically perform a visual check of the pilot and burner flames. Compare them to the illustrations below. (Figs. 50, 51, 52)

If the flame patterns appear abnormal contact a qualified service provider for service and adjustment.

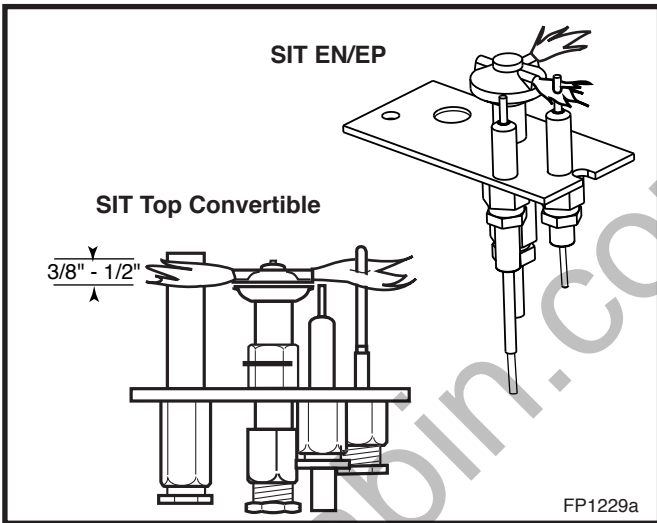

Fig. 50 Correct pilot flame appearance.

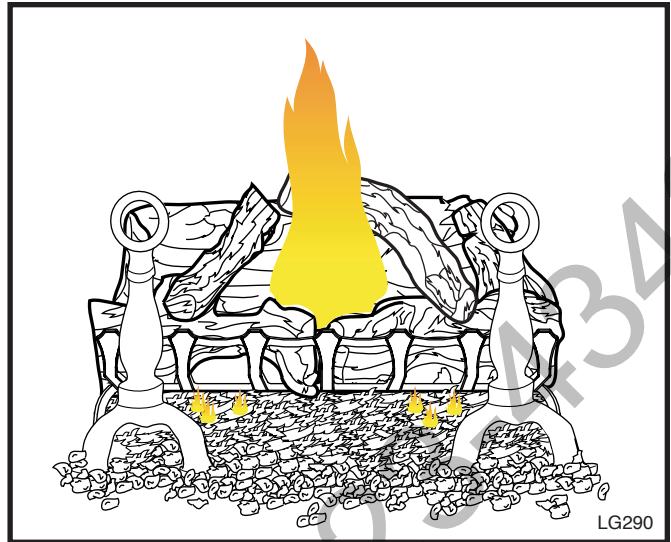

Fig. 51 DVT44 burner flame pattern.

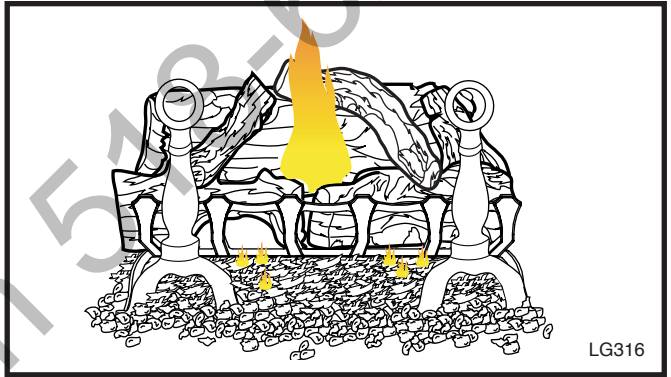

Fig. 52 DVT38 burner flame pattern.

Lighting And Operating Instructions

FOR YOUR SAFETY READ BEFORE LIGHTING

WARNING: If you do not follow these instructions exactly, a fire or explosion may result causing property damage, personal injury or loss of life.

- This appliance has a pilot which must be lit manually. When lighting the pilot follow these instructions exactly.
- BEFORE LIGHTING smell all around the heater area for gas. Be sure to smell next to the floor because some gas is heavier than air and will settle on the floor.

WHAT TO DO IF YOU SMELL GAS

- Do not try to light any appliance
- Do not touch any electric switch
- Do not use any phone in your building
- Immediately call your gas supplier from a neighbor's phone. Follow the gas supplier's

instructions.

- If you cannot reach your gas supplier, call the Fire Department
- Use only your hand to push in or turn the gas control knob. Never use tools. If the knob will not push in or turn by hand, do not try to repair it, call a qualified service technician. Force or attempted repair may result in a fire or explosion.
 - Do not use this appliance if any part has been under water. Immediately call a qualified service technician to inspect the heater and to replace any part of the control system and any gas control which has been under water.

Lighting Instructions

- STOP!** Read the "For Your Safety" information first and locate the control panel before lighting.
- For TN/TP appliances ONLY, go on to Step 3. For RN/RP appliances turn the ON/OFF switch to OFF position or set thermostat to lowest setting.
- Push in gas control knob slightly and turn to "OFF" position. Do not force.

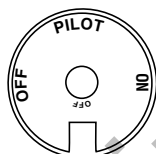

SIT NOVA

- Wait five (5) minutes to clear out any gas. Then smell for gas, including near the floor. If you smell gas, STOP! Follow "What to do if you smell gas" in your "For your safety". If you do not smell gas, go to the next step.
- Remove glass door before lighting pilot. (See Glass Frame Removal section).
- Visually locate pilot assembly by the main burner.
- Turn knob on gas control to "PILOT".

- Push in control knob all the way and hold in until pilot indicator pointer moves from green to red (pilot is on). If the pointer does not move to red after several attempt, repeat Steps 3 to 7. When pointer moves to red, hold control knob in for

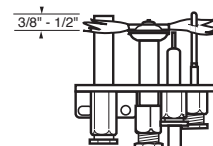

about one (1) minute. release knob and it will pop back into original position. Pilot should remain lit. If it goes out, repeat Steps 3 to 7.

- If knob does not pop up when released, stop and immediately call your service technician or gas supplier.
 - If after several tries, the pilot will not stay lit, turn the gas control knob to "OFF" and call your service technician or gas supplier.
- Replace glass door.
 - Turn gas control knob to "ON" position.
 - For RN/RP appliances turn the On/Off switch to "ON" position or set thermostat to desired setting.

To Turn Off Gas To Heater

- Turn the On/Off switch to Off position or set the thermostat to lowest setting.
- Turn off all electric power to the fireplace if service is to be performed.
- Open control access panel.
- Push in gas control knob slightly and turn clockwise  to "OFF". Do not force.
- Close control access panel.

Lighting and Operating Instructions

For Fireplaces equipped with SIT822 Gas Valve (EN or EP)

Warning: If you do not follow these instructions exactly, a fire or explosion may result causing property damage, personal injury and loss of life.

FOR YOUR SAFETY READ THE FOLLOWING WARNINGS BEFORE LIGHTING THE APPLIANCE

- A. This fireplace is equipped with an ignition device which automatically lights the pilot. **DO NOT** try to light the pilot by hand.
- B. **BEFORE OPERATING**, smell all around the appliance area for gas. Be sure to smell next to the floor because some gas is heavier than the air and will settle on the floor.

What to do if you smell gas

- Do not try to light any appliance
- Do not operate any electrical switch.
- Do not use any phone in your building.
- Immediately call your gas supplier from a neighbor's phone.

Follow the gas suppliers instructions.

- If you cannot contact your gas supplier call the Fire Department
- C. Use only your hand to push in or turn the gas control knob. Never use tools. If the knob will not push in or turn by hand do not try to repair it, call a qualified service technician. Force or attempting repair may result in a fire or explosion.
- D. Do not use this appliance if any part has been under water. Immediately call a qualified service technician to inspect the appliance and replace any part of the control system and any gas control that has been under water.

Lighting Instructions

1. **STOP!** Read the safety information above and locate the control panel before continuing.
2. Turn off all electrical power to the appliance.
3. This appliance is equipped with an ignition device which automatically lights the pilot. **DO NOT** try to light the pilot by hand.
4. Access the gas control by lowering the lower access door (ouvre assembly).
5. Turn the remote switch, if used, OFF. Turn the wireless remote, if used, OFF.
6. Wait five (5) minutes to clear out any gas. Then smell for gas, including near the floor. If you smell gas STOP. Follow instructions B in the safety warnings above. If you do not smell gas go onto the next step.
7. Close the access door.
8. Turn ON all electrical power to the appliance.
9. Turn remote switch or wireless remote to "ON".
10. If the appliance will not operate, follow the instructions TURNING OFF THE GAS TO THE APPLIANCE and call your service technician or gas supplier.

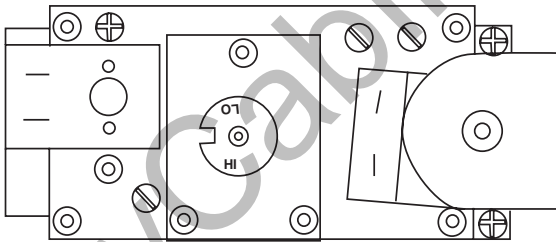

Turning Off the Gas to the Appliance

1. Turn the remote switch to the "OFF" position.
2. Turn OFF all electrical power to the fireplace if service is required.
3. Open the lower access panel.
4. Turn the shut-off valve on the gas line to the "OFF" position.

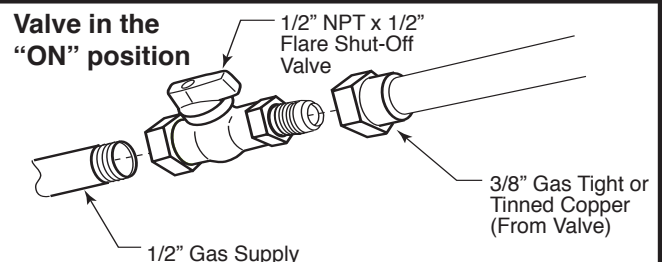

Troubleshooting the Gas Control System

SIT NOVA 820 MILLIVOLT VALVE

NOTE: Before trouble shooting the gas control system, be sure external gas shut off is in the "On" position.

Symptom	Possible Causes	Corrective Action
1. Spark ignitor will not light	A. Defective or misaligned electrode at pilot	Using a match, light pilot. If pilot lights, turn off pilot and push the red button again. If pilot will not light - check gap at electrode and pilot-should be 1/8" to have a strong spark.
	B. Defective ignitor (Push Button)	With the control knob in the pilot position, push the control knob all the way and hold. Check for spark at electrode and pilot. If no spark to pilot, and electrode wire is properly connected, replace the battery in the ignitor module and try again. Refer to Maintenance Section. If the problem still exists, replace the ignitor module box.
2. Pilot will not stay lit after carefully following lighting instructions	A. Defective pilot generator (thermocouple), remote wall switch	Check pilot flame. Must impinge on thermocouple/thermopile. NOTE: This pilot burner assembly utilizes both a thermocouple and a thermopile. The thermocouple operates the main valve operation (On and Off). Clean and or adjust pilot for maximum flame impingement on thermopile and thermocouple.
	B. Defective automatic valve	Turn valve knob to "Pilot". Maintain flow to pilot; millivolt meter should read greater than 10mV. If the reading is okay and the pilot does not stay on, replace the gas valve. NOTE: An interrupter block (not supplied) must be used to conduct this test.
3. Pilot burning, no gas to main burner	A. Wall switch or wires defective	Check wall switch and wires for proper connections. Jumper wire across terminals at wall switch, if burner comes on, replace defective wall switch.. If okay, jumper wires across wall switch wires at valve, if burner comes on, wires are faulty or connections are bad.
	B. Thermopile may not be generating sufficient millivoltage	<ol style="list-style-type: none"> 1. Be sure wire connections form thermopile at gas valve terminals are tight and thermopile is fully inserted into pilot bracket. 2. One of the wall switch wires may be grounded. Remove wall switch wires form valve terminals if pilot now stays lit, trace wall switch wiring for ground. May be grounded to fireplace or gas supply. 3. Check thermopile with millivolt meter. Take reading at thermopile terminals of gas valve. Should read 250-300 millivolts (minimum 150) while holding valve knob depressed in pilot position and wall switch "Off". Replace faulty thermopile if reading is below specified minimum.
	C. Plugged burner orifice	Check burner orifices for debris and remove.
	D. Defective automatic valve operator	Turn valve knob to "On", place wall switch to "On" millivolt meter should read greater than 150mV. If the reading is okay and the burner does not come on, replace the gas valve.
4. Frequent pilot outage problem	A. Pilot flame may be too low or blowing (high) causing the pilot safety to drop out	Clean and/or adjust pilot flame for maximum flame impingement on thermopile and thermocouple.
	B. Possible blockage of the vent terminal	Check the vent terminal for blockage (recycling the flue gases).

Troubleshooting the Gas Control System

SIT 822 Valve with a Honeywell Electronic Ignitor

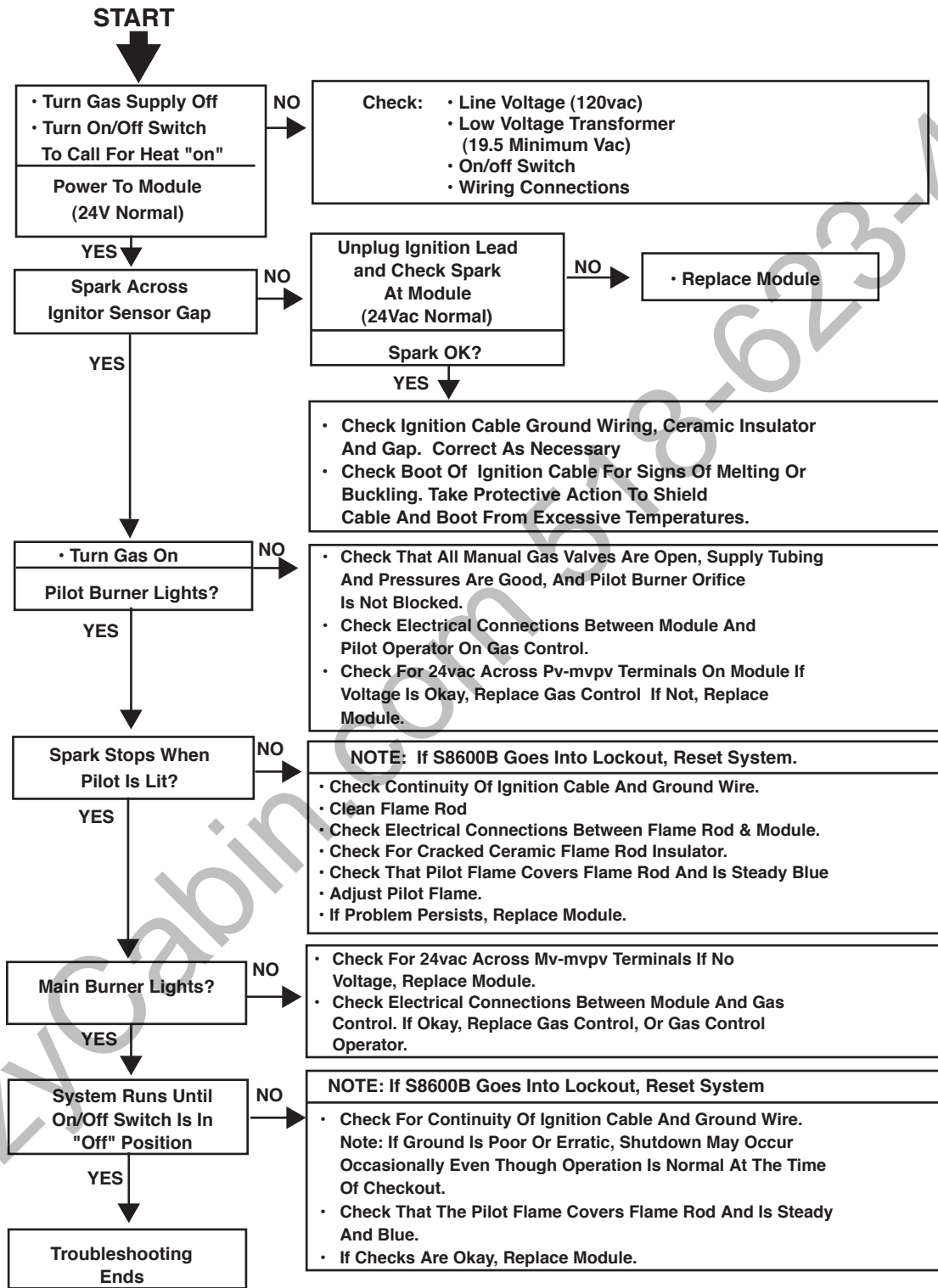

Fuel Conversion Instructions

WARNING! This conversion kit shall be installed by a qualified service agency in accordance with the manufacturer's instructions and all applicable codes and requirements of the authority having jurisdiction. If the information in these instructions is not followed exactly, a fire, explosion or production of carbon monoxide may result causing property damage, personal injury or loss of life. The qualified service agency is responsible for the proper installation of this kit. The installation is not proper and complete until the operation of the converted appliance is checked as specified in the manufacturer's instructions supplied with the kit.

CAUTION: The gas supply shall be shut off prior to disconnecting the electrical power, before proceeding with the conversion.

Avertissement: Cette trousse de conversion ne doit être installée que par le représentant d'un organisme qualifié et conformément aux instructions du fabricant et aux codes et exigences pertinentes de l'autorité compétente. Quiconque ne respecte pas à la lettre les instructions du présent guide risque de déclencher un incendie, une explosion ou le dégagement de monoxyde de carbone entraînant des dommages matériels, des lésions corporelles ou la perte de vies humaines. L'organisme qualifié qui effectue les travaux est responsable de l'installation de cette trousse. L'installation n'est pas terminée tant que le fonctionnement de l'appareil converti n'a pas été vérifié selon la notice du fabricant qui accompagne la trousse.

ATTENTION: Avant d'effectuer la conversion, coupez d'abord l'alimentation en gaz, ensuite, coupez l'alimentation électrique.

Conversion Precautions

Allow unit to cool if it has been operating.

Before proceeding with conversion, turn control knob on valve to OFF and turn gas supply OFF. Turn OFF any electricity that may be going to appliance.

Conversion Procedure

1. Remove glass frame. Refer to Glass Frame Assembly section on Page 20.
2. Remove lava rock, volcanic rock, embers and logs.
CAUTION: Logs may be hot.
3. With a Phillips or Robertson screwdriver, remove the two (2) screws holding the fettle to the burner assemblies. With a hex, remove the two (2) hex nuts holding

the burner tube to the front of the burner assembly. Remove burner tube.

4. Remove two (2) hex nuts holding the left burner leg. Remove burner leg. (Fig. 53)

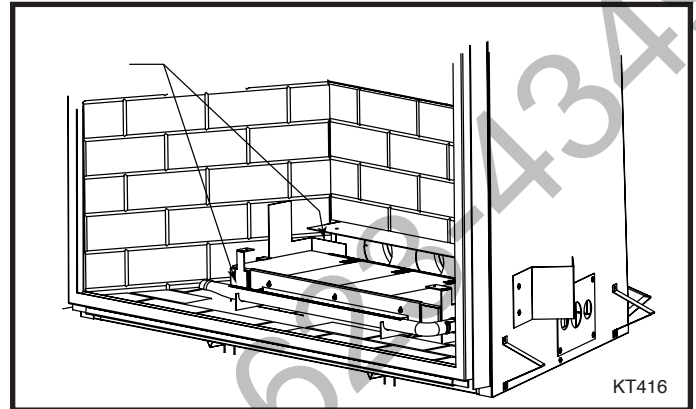

Fig. 53 Use 3/8" socket to remove hex nuts holding left burner leg.

5. Slide the burner housing assembly to the left and away.
6. Replace the three (3) injectors. Refer to Table 1.
7. Replace pilot orifice.
8. Remove pilot hood by lifting up. (Fig. 54) **NOTE:** It is not necessary to remove the pilot tube for conversion.
9. Remove pilot orifice with 5/32" Allen wrench. (Fig. 55)

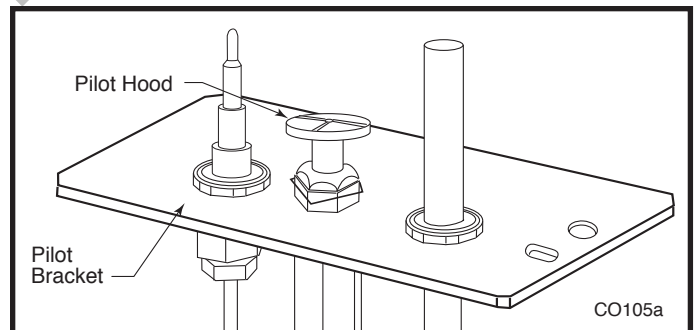

Fig. 54 Remove pilot hood.

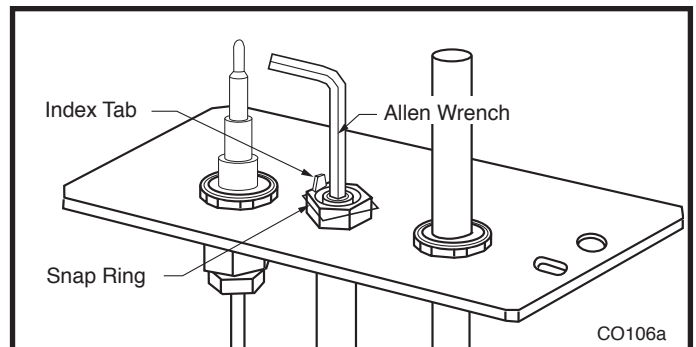

Fig. 55 Remove pilot orifice.

10. Install the conversion orifice.
11. Reinstall pilot hood. Be sure to align hood with index tab.
12. Open the control panel and remove the cover by removing two (2) screws. While holding the valve cover plate with one hand, disconnect the wiring to the switch and the pilot indicator. **NOTE:** Do not allow the valve cover plate to hang from the pilot wires as this could damage the wires. Remove the extension knob(s). Replace the valve regulator.
13. Using the TORX T20 bit remove and discard the three (3) pressure regulator mounting screws (A), pressure regulator tower (B) and the spring and diaphragm assembly (C). (Fig. 56)

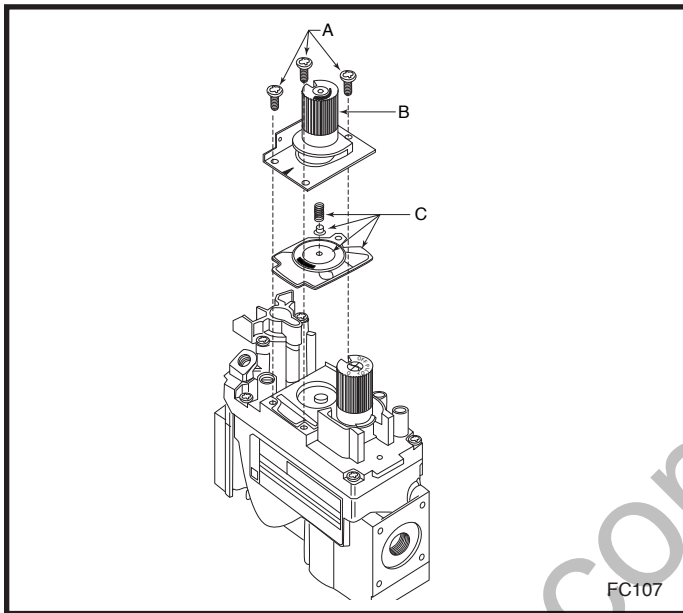

Fig. 56 Remove valve regulator.

14. Insure the rubber gasket (D) is properly positioned and install the new HI/LO pressure regulator assembly to the valve using the new screws (E) supplied with the kit. Tighten the screws securely. (Ref. torque = in/lb) (Fig. 57)
15. Install the enclosed identification label (F) to the valve body where it can easily be seen. (Fig. 57)
16. Regulator conversion complete.
17. Test for Leaks
 - Apply gas to the system and light the pilot.
 - With a soapy solution check for leaks around the pilot assembly where the tube enters the pilot assembly. Tighten fitting if necessary.

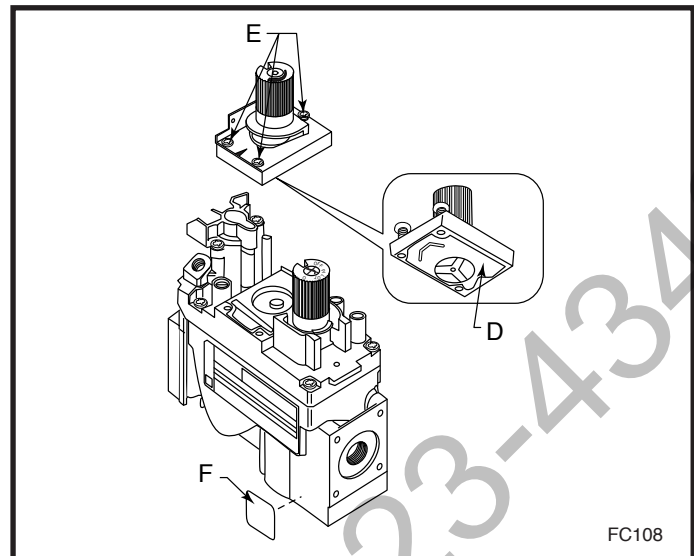

Fig. 57 Replace regulator.

- Light the main burner and check for leaks around the new pressure regulator assembly. Tighten screws if necessary.
 - With the main burner "ON" check for leaks around the burner orifice. Be careful of the burner flame. Tighten orifice if necessary.
 - With the main burner "ON" rotate the HI/LO knob and verify proper burner operation.
18. Replace burner to original position.
 19. Replace burner leg.
 20. Replace burner tube and fettle.
 21. Follow instructions on Page 22 to reinstall logs, lava rock, volcanic rock and embers.
 22. Replace glass frame.
- Conversion complete.

Pilot Flame Adjustment

Typically, the top 3/8" or 1/2" of the thermopile should be engulfed in the pilot flame. (Page 24, Fig. 50)

To adjust pilot burner:

1. Remove pilot adjustment cap located on valve.
2. Adjust pilot screw to provide properly sized flame.
3. Replace pilot adjustment cap.

Table 1 Injector Orifice Size Matrix

Conversion to Natural Gas									
Kit #	Model	Burner Orifice						Input (BTU/hr)	
		Front	Part #	Middle	Part #	Rear	Part #	Minimum	Maximum
20006987	DVT38RP	#56	30000336	#56	30000336	#31	20006927	36,000	46,000
20006412	DVT44RP	#52	30000331	#56	30000336	#28	20006173	37,000	60,000
Conversion to LP									
Kit #	Model	Burner Orifice						Input (BTU/hr)	
		Front	Part #	Middle	Part #	Rear	Part #	Minimum	Maximum
20006988	DVT38RN	#69	30000513	#67	30000338	#50	30000337	34,000	46,000
20006414	DVT44RN	#57	20004587	#63	20006251	#49	20006252	45,000	60,000

Maintenance

It is important to keep the burner and the burner compartment clean. At least once per year the logs and lava rock/ember material should be removed and the burner compartment vacuumed and wiped out. Remove and refit the logs as per the instructions in this manual.



Always handle the logs with care as they are fragile and may also be hot if the fireplace has been in use.

Cleaning the Standing Pilot Control System

The burner and control system consist of:

- burner tube
- gas orifice
- pilot assembly
- thermopile
- gas valve

Most of these components may require only an occasional checkup and cleaning and some may require adjustment. **If repair is necessary, it should be performed by a qualified technician.**

1. Turn off pilot light at gas valve.
2. Allow fireplace to cool if it has been operating.
3. Remove window frame assembly. (Refer to Window Frame Assembly Removal section.)
4. Remove logs.
5. Vacuum burner compartment especially around orifice primary air openings.
6. Visually inspect pilot. Brush or blow away any dust or lint accumulation.
7. Reinstall logs.
8. Ignite pilot - Refer to Lighting Instructions.
9. Reinstall window frame assembly.

To obtain proper operation, it is imperative that the pilot and burner's flame characteristics are steady, not lifting or floating.

Typically, the top 3/8" to 1/2" of the thermopile/sensing electrode should be engulfed in the pilot flame. (Refer to Page 24, Figure 48)

To adjust pilot burner: (by qualified service technician)

1. Remove pilot adjustment cap
2. Adjust pilot screw to provide properly sized flame.
3. Replace pilot adjustment cap.

Cleaning Electronic Ignition System

The Electronic Ignition burner/control system consists of:

- main burner
- gas orifice
- pilot burner
- 24VAC valve with transformer

Taking care of the Electronic Ignition units is identical to taking care of the Standing Pilot models.

Battery Replacement for Ignitor Module

1. Open control panel box door.
2. Remove the extension knob(s).
3. Remove the valve cover by removing the two (2) screws securing the valve cover plate to the box. While holding the valve cover plate with one hand, disconnect the wiring to the switch and the pilot indicator. **NOTE:** Do not allow the valve cover plate to hang from the pilot indicator wires as this could damage the wires.
4. Replace the battery (AA) in the ignitor module located at the top left corner.
5. Replace wires, valve cover, extension knob(s) in reverse order. **NOTE:** The pilot indicator body is labelled +/-, make sure the positive wire on the pilot indicator goes to ground and the negative goes to the plug between the valve and the thermocouple.

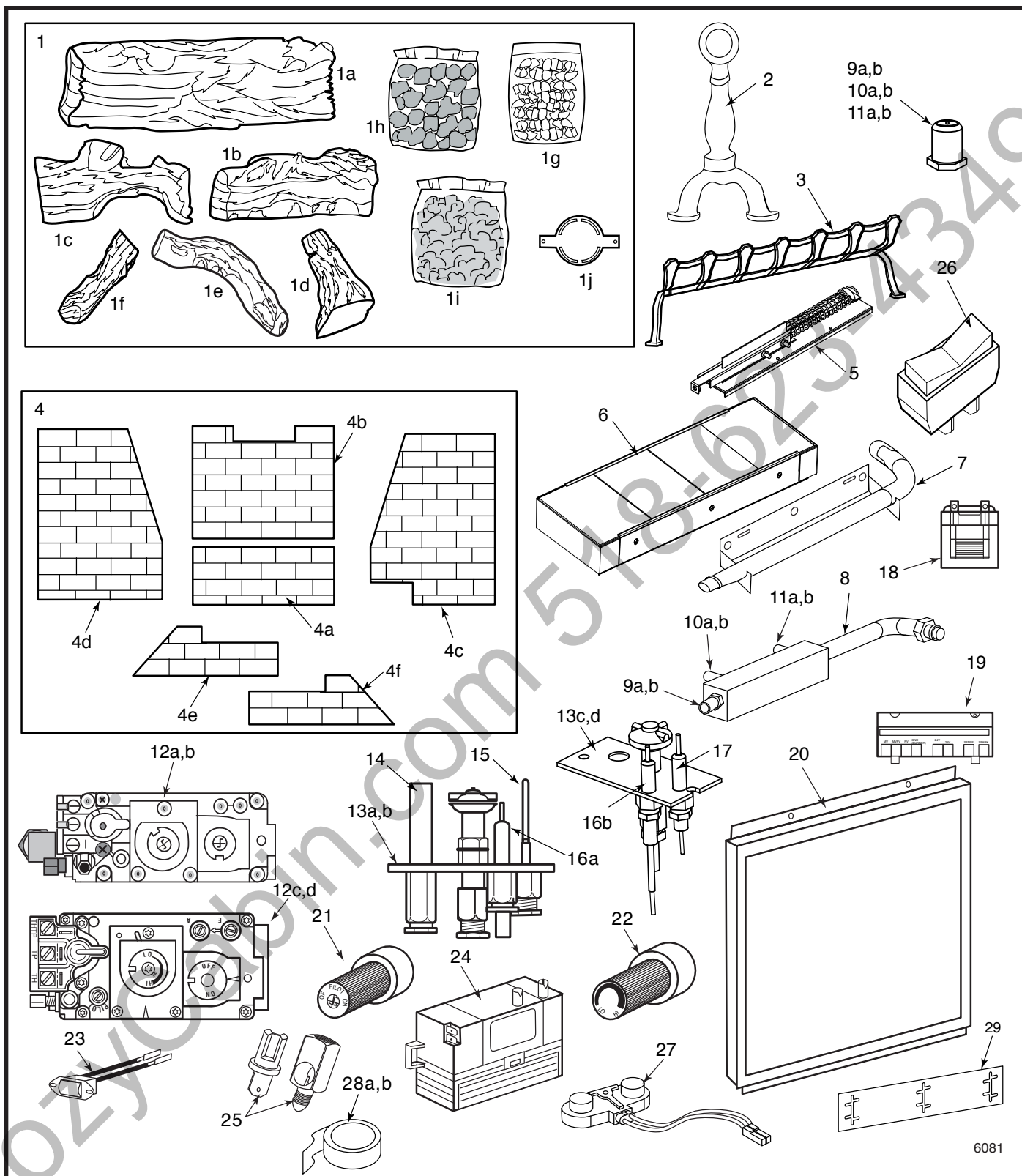

6081

CFM Specialty Home Products reserves the right to make changes in design, materials, specifications, prices and discontinue colors and products at any time, without notice.

DVT38, DVT44

DVT38, DVT44 (continued)

Ref.	Description	DVT38	DVT44
1.	Log Set (Complete)	20006961	20006378
1a.	Log Rear F1	20006970	20006330
1b.	Log Right Front F2	20006971	20006331
1c.	Log Left Front F3	20006972	20006332
1d.	Log Top Right F4	20006333	20006333
1e.	Log Top Middle F5	20006334	20006334
1f.	Log Top Left F6	20006335	20006335
1g.	Small Lava Rock Package	57897	57897
1h.	Volcanic Rock	20000376	20000376
1i.	Bag of Glowing Embers	0005219	0005219
1j.	Restrictor	20006959	20005817
2.	Andiron Assembly	20006491	20006491
3.	Fettle	20006960	20005977
4.	Refractory Set Complete	20006823	20006384
4a.	Rear Refractory Lower	20006589	20005824
4b.	Rear Refractory Upper	20006590	20005825
4c.	Right Side Refractory	20006591	20005826
4d.	Left Side Refractory	20006592	20005827
4e.	LH Lower Refractory	20006593	20005876
4f.	RH Lower Refractory	20006594	20005879
5.	Spring Latch Assembly	20005788	20005788
6.	Burner Housing Assembly	20006576	20005834
7.	Burner Tube Assembly	20006584	20005884
8.	Manifold Tube Assembly	20005852	20005852
9a.	Front Orifice #52 (.635") - Natural	--	30000331
9a.	Front Orifice #56 (.0465") - Natural	30000336	--
9b.	Front Orifice #57 (.043") - LP	--	20004587
9b.	Front Orifice #69 (.0292") - LP	30000513	--
10a.	Middle Orifice #56 (.0465") - Natural	30000336	30000336
10b.	Middle Orifice #63 (.037") - LP	--	20006251
10b.	Middle Orifice #67 (.032") - LP	30000338	--
11a.	Rear Orifice #28 (.1405") - Natural	--	20006173
11a.	Rear Orifice #31 (.120") - Natural	20006927	--
11b.	Rear Orifice #49 (.073") - LP	--	20006252
11b.	Rear Orifice #50 (.070") - LP	30000337	--
12a.	Valve Nova SIT 0.820.652 - RN	52677	52677
12b.	Valve Nova SIT 0.820.651 - RP	52678	52678
12c.	Valve Nova SIT 0.822.632 - EN 24v/60Hz Solenoid Manual HI/LO	57884	57884
12d.	Valve Nova SIT 0.822.631 - EP 24v/60Hz Solenoid Manual HI/LO	57883	57883
13a.	Pilot Assy 3way N/DV Top Convertible - RN	20006144	20006144
13b.	Pilot Assy 3way N/DV Top Convertible - RP	20006145	20006145
13c.	Pilot Assy 3way N/DV Top Convertible - EN	20006146	20006146
13d.	Pilot Assy 3way N/DV Top Convertible - EP	20006147	20006147
14.	Thermopile 75"	20006148	20006148
15.	Thermocouple 72"	20006149	20006149
16a.	Electrode Ignitor 79" RN/RP	20006150	20006150

DVT38, DVT44 (continued)

Ref.	Description	DVT38	DVT44
16b.	Electrode Ignitor 79" EN/EP	20008059	20008059
17.	Sensing Electrode 79"	20006151	20006151
18.	Transformer	7522409	7522409
19.	Ignitor Module Honeywell 58600B1025	20000005	20000005
20.	Glass Frame Assembly	20006566	20005947
21.	Knob Extension Pilot/Stat	10000166	10000166
22.	Knob Extension HI/LO	10000165	10000165
23.	Pilot Indicator	20005908	20005908
24.	Ignitor Module	20005909	20005909
25.	Pilot Indicator Plug	20006250	20006250
26.	Switch Rocker	53606	53606
27.	Spark Cable Connection	20005807	20005807
28a.	Outer Pipe Aluminum Foil Tape	20006169	20006169
28b.	Inner Pipe Aluminum Foil Tape	20008253	20008253
29.	Plate, Restrictor	20006663	20006757
30.	Milpack Tube (not shown)	53326	53326

Fuel Conversion Kits

Conversion Kit, NG to LP

DVT44RN & EN Kit # 20006414

DVT38RN & EN Kit # 20006988

Conversion Kit, LP to NG

DVT44RP & EP Kit # 20006412

DVT38RP & EP Kit # 20006987

Accessories

Remote Controls

Optional remote control units are available to control different functions of the appliance.

Model	Function(s) Controlled
MRC1	On/Off
MRC2	On/Off and Temperature
MRC3	On/Off and Temperature control with digital display and programmable 24-hour clock
IMT	Wall-mounted Thermostat Control (For use in Canada ONLY)

Full Surround Mantel

The Chateau Full Surround has been designed for installation with the DVT38 and DVT44 Chateau fireplaces. Hinged face panels on the surround allow access to the fireplace control box and gas valve. Accurate framing of the fireplace is critical to proper installation. Refer to the instructions supplied with the Surround for complete details.

CAUTION: If you are framing with the plan to use the surround mantel mentioned above, it is extremely critical to meet the dimensions provided, especially if the mantel is not available at the time of framing.

NOTE: In the event the mantel is not available at the time of framing the unit/valve box, you must make the spacer on the left side of the valve box in order to access the valve box door through the opening in the mantel.

Fireplace	Full Surround Mantel
DVT38	CHFN049S
DVT38	CHFWC49S
DVT38	CHFPR49S
DVT44	CHFPR55
DVT44	CHFWC55
DVT44	CHFN055

NOTE: The vertical dimension is shown from the floor where the fireplace sits. If a marble hearth extension, or other type of material is used, the vertical framing will increase by the thickness of the material used to accommodate the height difference when the mantel sits on the hearth extension.

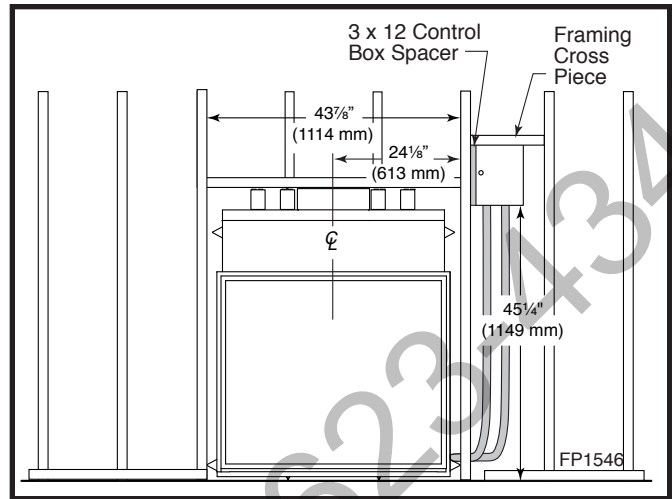

Fig. 58 Chateau DVT38 Full Surround Mantel framing.

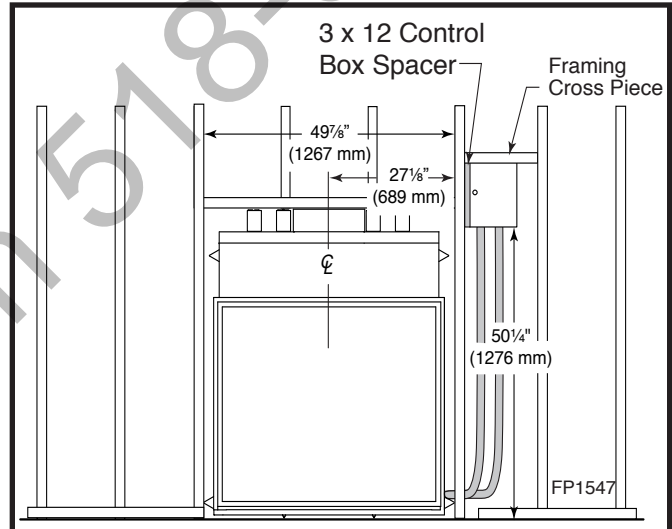

Fig. 59 Chateau DVT44 Full Surround Mantel framing.

CozyCabin.com 518-623-4349

CozyCabin.com 518-623-4349

LIMITED LIFETIME WARRANTY

PRODUCT COVERED BY THIS WARRANTY

All Vermont Castings gas stoves, gas inserts, and gas fireplaces, and all Majestic or Northern Flame brand gas fireplaces equipped with an Insta-Flame Ceramic Burner, or standard steel tube burner.

BASIC WARRANTY

Vermont Castings, Majestic Products (hereinafter referred to collectively as the Company) warrants that your new Vermont Castings or Majestic Gas Fireplace/Stove is free from manufacturing and material defects for a period of one year from the date of purchase, subject to the following conditions and limitations.

EXTENDED LIFETIME WARRANTY

The heat exchanger, where applicable, and combustion chamber of every Vermont Castings or Majestic gas product is warranted for life against through wall perforation. All appliances equipped with an Insta-Flame Ceramic Burner have limited lifetime coverage on the ceramic burner plaque. Warrantees are made to the original owner subject to proof of purchase and the conditions and limitations listed on this Warranty Document

COMPONENT WARRANTY

CAST IRON: All external and internal cast iron parts are warranted for a period of three years.

Note: On porcelain enamel finished external parts and accessories The Company offers no Warranty on chipping of enamel surfaces. Inspect all product prior to accepting it for any damage to the enamel.

The salt air environment of coastal areas or a high humidity environment can be corrosive to the porcelain enamel finish. These conditions can cause rusting of the cast iron beneath the porcelain enamel finish, which will cause the finish to flake off.

Dye lot variations with replacement parts and/or accessories can occur and are not covered by warranty.

GLASS DOORS: Glass doors are covered for a period of one year. Glass doors are not warranted for breakage due to misuse or accident. Glass doors are not covered for discoloration or burned in stains due to environmental issues, or improper cleaning and maintenance.

BRASS PLATED PARTS AND ACCESSORIES: Brass parts should be cleaned with Lemon oil only. Brass cleaners cannot be used. Mortar mix and masonry cleaners may corrode the brass finish. The Company will not be responsible for, nor will it warrant any brass parts which are damaged by external chemicals or down draft conditions.

GAS VALVES: Gas valves are covered for a period of one year

ELECTRONIC AND MECHANICAL COMPONENTS: Electronic and mechanical components of the burner assembly are covered for one year. All steel tube burners are warranted for one year.

ACCESSORIES: Unless otherwise noted all components and Vermont Castings, Majestic Products company supplied accessories are covered for a period of one year.

CONDITIONS AND LIMITATIONS

- This new Vermont Castings or Majestic product must be installed by a competent, authorized, service contractor. A licensed technician, as prescribed by the local jurisdiction must perform any installation/service work. It must be installed and operated at all times in accordance with the Installation and Operating instructions furnished with the product. Any alteration, willful abuse, accident, or misuse of the product shall nullify this warranty.
- This warranty is non-transferable, and is made to the original owner, provided that the purchase was made through an authorized supplier of the Company.
- The customer must pay for any Authorized Dealer in-home travel fees or service charges for in-home repair work. It is the dealers option whether the repair work will be done in the customer's home or in the dealer's shop.
- If upon inspection, the damage is found to be the fault of the manufacturer, repairs will be authorized at no charge to the customer parts and/or labor.

- Any part and/or component replaced under the provisions of this warranty is covered for six months or the remainder of the original warranty, whichever is longest.
- This warranty is limited to the repair of or replacement of part(s) found to be defective in material or workmanship, provided that such part(s) have been subjected to normal conditions of use and service, after said defect is confirmed by the Company's inspection.
- The company may, at its discretion, fully discharge all obligations with respect to this warranty by refunding the wholesale price of the defective part(s)
- Any installation, labor, construction, transportation, or other related costs/expenses arising from defective part(s), repair, replacement, or otherwise of same, will not be covered by this warranty, nor shall the Company assume responsibility for same. Further, the Company will not be responsible for any incidental, indirect, or consequential damages except as provided by law.
- SOME STATES DO NOT ALLOW FOR THE EXCLUSION OR LIMITATIONS OF INCIDENTAL AND CONSEQUENTIAL DAMAGES OR LIMITATIONS ON HOW LONG AN IMPLIED WARRANTY LASTS, SO THE ABOVE LIMITATIONS MAY NOT APPLY TO YOUR CIRCUMSTANCES. THIS WARRANTY GIVES YOU SPECIFIC RIGHTS AND YOU MAY HAVE OTHER RIGHTS WHICH VARY FROM STATE TO STATE.
- All other warranties-expressed or implied- with respect to the product, its components and accessories, or any obligations/liabilities on the part of the Company are hereby expressly excluded.
- The Company neither assumes, nor authorizes any third party to assume on its behalf, any other liabilities with respect to the sale of this Vermont Castings, Majestic product
- The warranties as outlined within this document do not apply to chimney components or other non Vermont Castings, Majestic accessories used in conjunction with the installation of this product..
- Damage to the unit while in transit is not covered by this warranty but is subject to claim against the common carrier. Contact the dealer from whom you purchased your fireplace/stove (do not operate the appliance as this might negate the ability to process the claim with the carrier).
- The Company will not be responsible for:
 - a) Down drafts or spillage caused by environmental conditions such as near-by trees, buildings, roof tops, hills, or mountains.
 - b) Inadequate ventilation or negative air pressure caused by mechanical systems such as furnaces, fans, clothes dryers, etc.
- This warranty is void if:
 - a) The fireplace has been operated in atmospheres contaminated by chlorine, fluorine, or other damaging chemicals.
 - b) The fireplace has been subjected to prolonged periods of dampness or condensation
 - c) Any damages to the fireplace, combustion chamber, heat exchanger or other components due to water, or weather damage, which is the result of but not limited to, improper chimney/venting installation.
 - d) Any alteration, willful abuse, accident, or misuse of the product has occurred.

IF WARRANTY SERVICE IS NEEDED...

- 1) Contact your supplier. Make sure you have your warranty, your sales receipt, and the model/serial number of your Vermont Castings, Majestic product.
- 2) DO NOT ATTEMPT TO DO ANY SERVICE WORK YOURSELF.

Canada

ENERGUIDE

Look for the **EnerGuide**
Gas Fireplace Energy
Efficiency Rating in this brochure

Based on CSA P.4.1-02

Efficiency Ratings

Model	EnerGuide Ratings Fireplace Efficiency (%)
DVT38RN	47.1
DVT38RP	47.1
DVT38EN	48.2
DVT38EP	48.2
DVT44RN	50.1
DVT44RP	50.1
DVT44EN	51
DVT44EP	51

NATIONAL
FIREPLACE
INSTITUTE



CERTIFIED
www.nficertified.org

We recommend that our gas hearth products be installed and serviced by professionals who are certified in the U.S. by the National Fireplace Institute® (NFI) as NFI Gas Specialists.

CFM Specialty Home Products

410 Admiral Blvd. • Mississauga, Ontario, Canada L5T 2N6 • 905-670-7777
www.majesticproducts.com • www.vermontcastings.com