

**INSTALLER/CONSUMER
SAFETY INFORMATION**

**PLEASE READ THIS MANUAL
BEFORE INSTALLING AND
USING APPLIANCE**

WARNING!
IF THE INFORMATION IN THIS
MANUAL IS NOT FOLLOWED
EXACTLY, A FIRE OR EXPLO-
SION MAY RESULT CAUSING
PROPERTY DAMAGE, PER-
SONAL INJURY OR LOSS OF
LIFE.

FOR YOUR SAFETY
Installation and service must
be performed by a qualified
installer, service agency or
the gas supplier.

**WHAT TO DO IF YOU SMELL
GAS:**

- Do not try to light any
appliance.
- Do not touch any electric
switch; do not use any phone in
your building.
- Immediately call your gas
supplier from your neighbor's
phone. Follow the gas suppliers
instructions.
- If you cannot reach your gas
supplier call the fire
department.

**DO NOT STORE OR USE
GASOLINE OR OTHER FLAM-
MABLE VAPORS AND LIQUIDS
IN THE VICINITY OF THIS OR
ANY OTHER APPLIANCE.**

MAJESTIC VERMONT *Castings*

**Direct Vent
Models: DV360
DV580**

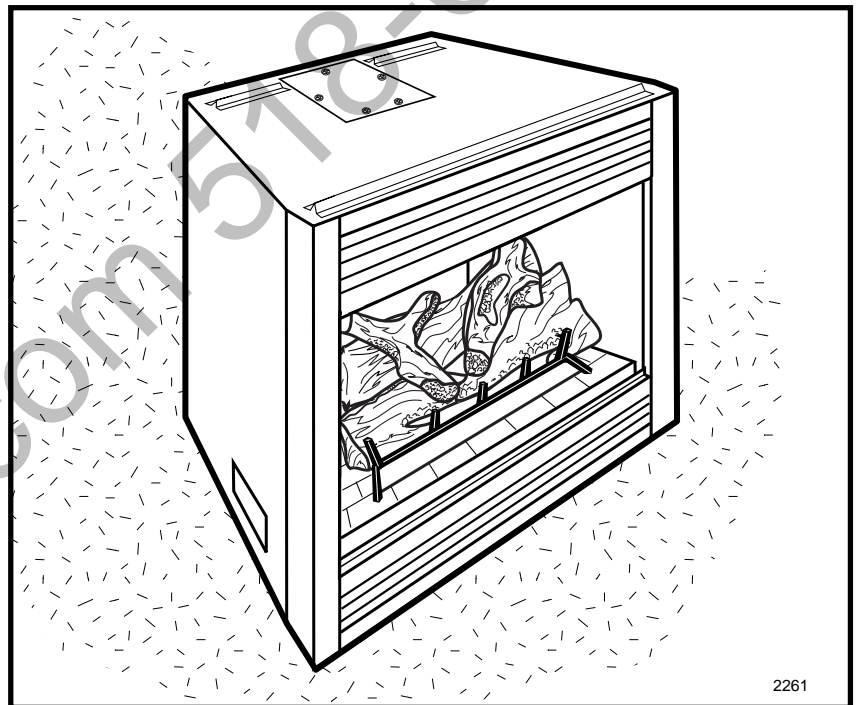

Homeowner's Installation and Operating Manual



Vermont Castings, Majestic Products

410 Admiral Blvd. • Mississauga, Ontario, Canada L5T 2N6 • 905-670-7777
www.majesticproducts.com • www.vermontcastings.com

INSTALLER: DO NOT DISCARD THIS MANUAL - LEAVE FOR HOMEOWNER

Table of Contents

PLEASE READ THE INSTALLATION & OPERATING INSTRUCTIONS BEFORE USING APPLIANCE.

Thank you and congratulations on your purchase of a Vermont Castings, Majestic Products fireplace.

IMPORTANT: Read all instructions and warnings carefully before starting installation. Failure to follow these instructions may result in a possible fire hazard and will void the warranty.

Installation & Operating Instructions

Important Curing/Burning Instructions	3
Locating Your Fireplace	3
Fireplace Dimensions	4
Clearance to Combustibles	6
Mantels	6
Hearth	6
Framing & Finishing	7
Final Finishing	7
Gas Specifications	7
Gas Inlet and Manifold Pressures	7
High Elevations	7
Gas Line Installation	7
Remote ON/OFF Switch Installation	8
Alternate Switch Location	8
EB-1 Electrical Box	8
Optional Top Vent Application	9

General Venting Information

General Venting	10
General Venting Information - Termination Location	11
General Information Assembling Vent Pipes	12
How to Use the Vent Graph	13
Rear Wall Vent Applications & Installation	13
Vertical Sidewall Applications & Installation	14
Below Grade Installation	17
Vertical Through-the-Roof Applications & Installation	18
Twist Lock Venting Components	21

Operating Instructions

Glass Information	21
Louvre Removal	21
Window Frame Assembly Removal	21
Glass Cleaning	21
Replacement of Ceramic Hearth Panels	21
Installation of Logs	22
Ember Material Placement	23
Lava Rock	23
Flame & Temperature Adjustment	23
Flame Characteristics	23
Inspecting the Venting System	23
Lighting and Operating Instructions (Honeywell Gas Valve)	24
Instructions for RF Comfort Valve	25
Troubleshooting Gas Control (Honeywell Gas Valve)	29
Troubleshooting Gas Control (SIT 820 Millivolt Gas Valve)	30
Fuel Conversion Instructions	31

Maintenance

Cleaning the Standing Pilot Control System	35
--	----

Replacement Parts

Optional Accessories

Fan Kits	40
Hard (Direct) Wire Hook Up	40
Remote Controls	41
Ceramic Refractory Panels	41
Decorative Bay Windows	41
Decorative Frame Trim	41

Warranty	43
-----------------------	----

Energide	44
-----------------------	----

Installation & Operating Instructions

This gas appliance should be installed by a qualified installer in accordance with local building codes and with current **CSA-B149.1** Installation codes for Gas Burning Appliances and Equipment. If the unit is being installed in a mobile home, the installation should comply with the current **CAN/CSA Z 240.4** code. For U.S.A Installations follow local codes and/or the current **National Fuel Gas Code, ANSI Z223.1/NFPA 54**.

FOR SAFE INSTALLATION AND OPERATION

PLEASE NOTE THE FOLLOWING:

1. This fireplace gives off high temperatures and should be located out of high traffic areas and away from furniture and draperies.
2. Children and adults should be alerted to the hazards of the high surface temperatures of this fireplace and should stay away to avoid burns or ignition of clothing.
3. Children should be carefully supervised when in the same room as your fireplace.
4. Under no circumstances should this fireplace be modified. Parts removed for servicing should be replaced prior to operating this fireplace again.
5. Installation and any repairs to this fireplace must be performed by a qualified installer, service agency or gas supplier. A professional service person should be contacted to inspect this fireplace annually. Make it a practice to have all of your gas fireplaces checked annually. More frequent cleaning may be required due to excess lint and dust from carpeting, bedding material, etc.
6. Control compartments, burners and air passages in this fireplace should be kept clean and free of dust and lint. Make sure the gas valve and pilot light are turned off before you attempt to clean this fireplace.
7. The venting system (chimney) of this fireplace should be checked at least once a year and if needed your venting system should be cleaned.
8. Keep the area around your fireplace clear of combustible materials, gasoline and other flammable vapor and liquids. This fireplace should not be used as a drying rack for clothing, nor should Christmas stocking or decorations be hung in the area of it.
9. Under no circumstances should any solid fuels (wood, coal, paper or cardboard etc.) be used in this fireplace.
10. The flow of combustion and ventilation air must not be obstructed in any way.
11. When fireplace is installed directly on carpeting, vinyl tile or any combustible material other than wood, this fireplace must be installed on a metal or wood panel extending the full width and depth of the fireplace.
12. This fireplace requires adequate ventilation and combustion air to operate properly.
13. This fireplace must not be connected to a chimney flue serving a separate solid fuel burning fireplace.
14. When the fireplace is not in use it is recommended that the gas valve be left in the OFF position.

Proposition 65 Warning: Fuels used in gas, woodburning or oil fired appliances, and the products of combustion of such fuels, contain chemicals known to the State of California to cause cancer, birth defects and other reproductive harm.
California Health & Safety Code Sec. 25249.6

This appliance may be installed in an aftermarket permanently located, manufactured home or mobile home, where not prohibited by local codes.

This appliance is only for use with the type of gas indicated on the rating plate. This appliance is not convertible for use with other gases, unless a certified kit is used.

IMPORTANT:

PLEASE READ THE FOLLOWING CAREFULLY

Remove any plastic from trim parts before turning the fireplace ON.

It is normal for fireplaces fabricated of steel to give off some expansion and/or contraction noises during the start up or cool down cycle. Similar noises are found with your furnace heat exchanger or car engine. It is not unusual for your Vermont Castings, Majestic Products company gas fireplace to give off some odor the first time it is burned. This is due to the manufacturing process.

Please ensure that your room is well ventilated -open all windows.

It is recommended that you burn your fireplace for at least ten (10) hours the first time you use it. If the optional fan kit has been installed, place the fan switch in the "OFF" position during this time.

Locating Your Fireplace

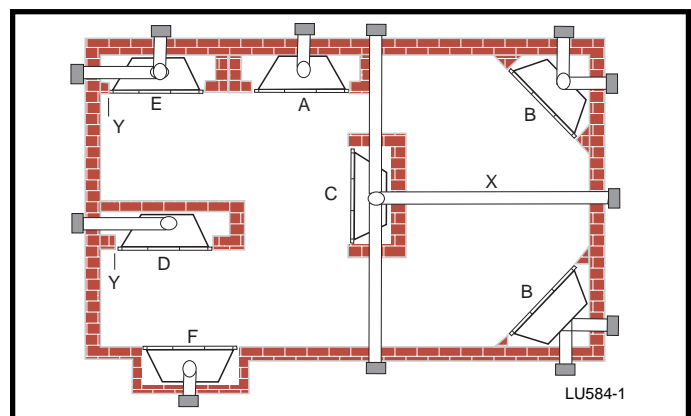

Fig. 1 Locating Gas Fireplace

- A) Flat on wall B) Cross corner C) **Island
D) *Room divider E) *Flat on wall corner F) Chase installation
Y) 6" minimum

Note (Fig. 1):

** Island (C) and Room Divider (D) installation is possible as long as the horizontal portion of the vent system (X) does not exceed 20 feet (610cm). See details in Venting Section.

* When you install your Vermont Castings, Majestic Products fireplace in (D) Room divider or (E) Flat on wall corner positions (Y), a minimum of 6 inches (153mm) clearance must be maintained from the perpendicular wall and the front of the fireplace.

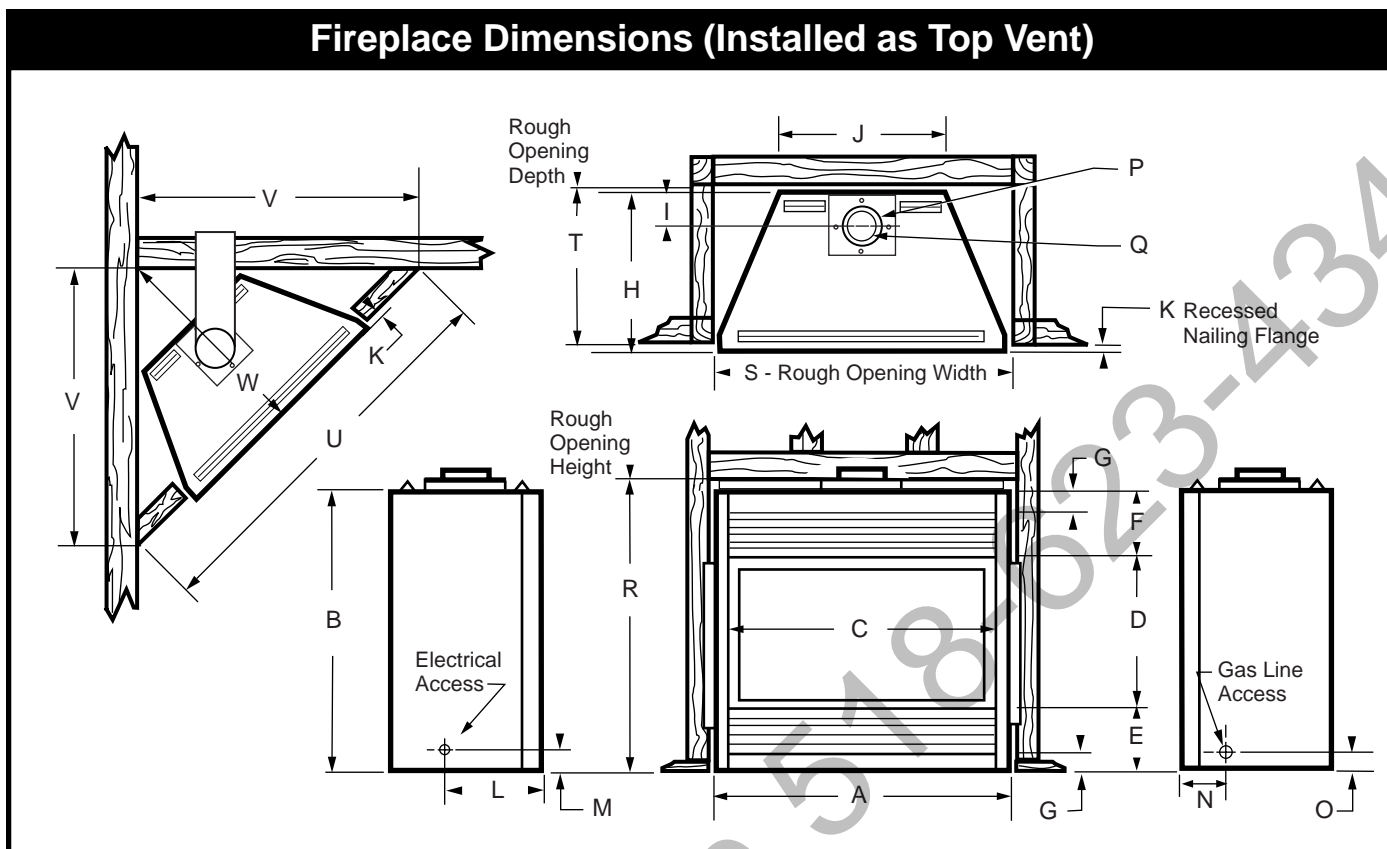

Fig. 2 Fireplace specifications and framing dimensions.

Ref.	DV360	DV580
A	41" (1041mm)	47" (1194mm)
B	37" (953mm)	41¼" (1048mm)
C	36" (914mm)	42" (1067mm)
D	24½" (622mm)	28½" (724mm)
E	7" (178mm)	7" (178mm)
F	6" (152mm)	6" (152mm)
G	1¼" (32mm)	1¼" (32mm)
H	19¼" (489mm)	23½" (591mm)
I	5½" (140mm)	5½" (140mm)
J	25" (635mm)	31" (787mm)
K	5/8" (16mm)	5/8" (16mm)
L	10¾" (273mm)	10¾" (273mm)
M	2" (51mm)	2" (51mm)
N	7⅝" (194mm)	11¼" (286mm)
O	1⅞" (48mm)	1⅞" (48mm)
P	7" (178mm) Dia.	7" (178mm) Dia.
Q	4" (102mm) Dia.	4" (102mm) Dia.
Framing Dimensions		
R	38¼" (978mm)	42½" (1080mm)
S	41¼" (1048mm)	47¼" (1200mm)
T	19¼" (489mm)	23½" (597mm)
U	62¼" (1581mm)	75" (1905mm)
V	44" (1118mm)	53" (1346mm)
W	31¾" (807mm)	38" (965mm)

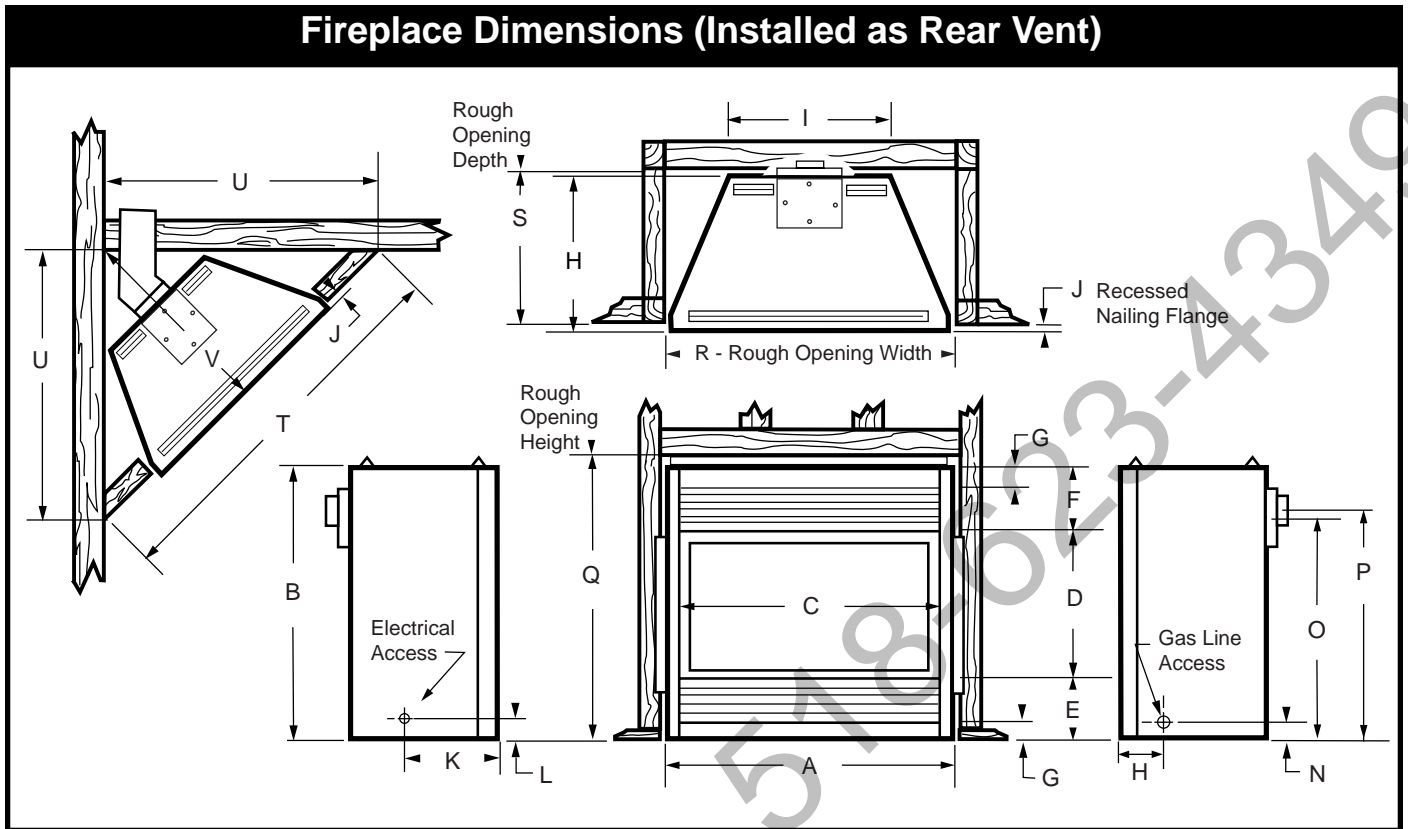

Fig. 3 Fireplace specifications and framing dimensions.

Ref.	DV360	DV580
A	41" (1041mm)	47" (1194mm)
B	37½" (953mm)	41¼" (1048mm)
C	36" (914mm)	42" (1067mm)
D	24½" (622mm)	28½" (724mm)
E	7" (178mm)	7" (178mm)
F	6" (152mm)	6" (152mm)
G	1¼" (32mm)	1¼" (32mm)
H	19¼" (489mm)	23½" (591mm)
I	25" (635mm)	31" (787mm)
J	5/8" (16mm)	5/8" (16mm)
K	10¾" (273mm)	10¾" (273mm)
L	2" (51mm)	2" (51mm)
M	7⅝" (194mm)	11¼" (286mm)
N	1⅞" (48mm)	1⅞" (48mm)
O	31⅓" (808mm)	35¾" (908mm)
P	32⅙" (827mm)	36⅙" (928mm)
Framing Dimensions		
Q	38½" (978mm)	42½" (1080mm)
R	41¼" (1048mm)	47¼" (1200mm)
S	19¼" (489mm)	23½" (597mm)
T	62¼" (1581mm)	75" (1905mm)
U	44" (1118mm)	53" (1346mm)
V	31¾" (807mm)	38" (965mm)

Clearance to Combustibles

Top of unit to ceiling 36" (914mm)
 Front of unit to combustibles 36" (914mm)

Appliance

Top 0" (0mm)
 Bottom 0" (0mm)
 Side 0" (0mm)
 Back 0" (0mm)

Venting

Concentric sections of DV Vent 1" (25mm)
 Nonconcentric sections of DV Vent
 Sides and bottom 1" (25mm)
 Top 2" (51mm)

Mantels

The height that a combustible mantel is fitted above the fireplace is dependent on the depth of the mantel. This also applies to the distance between the mantel leg (if fitted) and the fireplace.

For the correct mounting height and widths, refer to Figures 4a, 4b and the Mantel Chart below.

The distances and reference points are not affected by the fitting of a bay window front trim kit.

Noncombustible mantels and legs may be installed at any height and width around the appliance. When using paint or lacquer, it must be heat resistant to prevent discoloration.

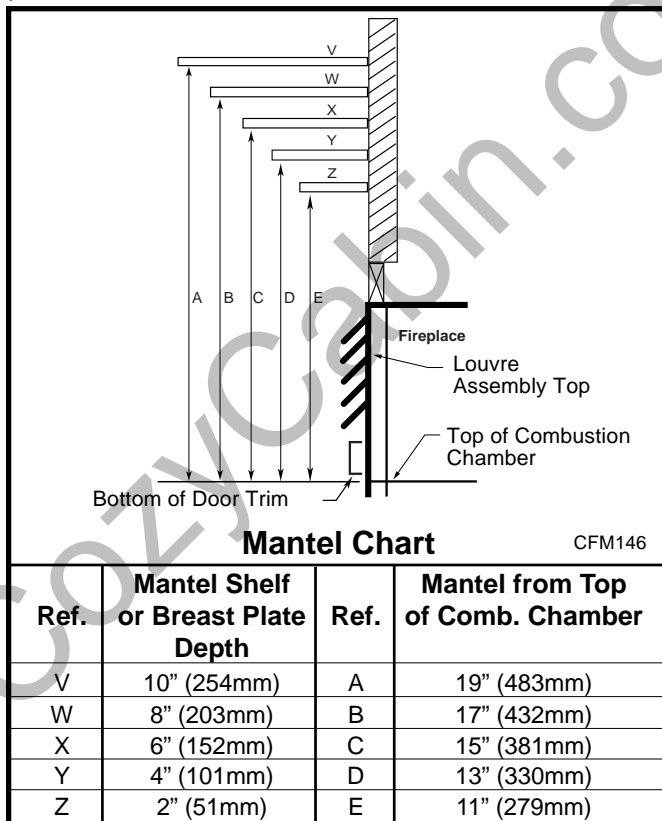
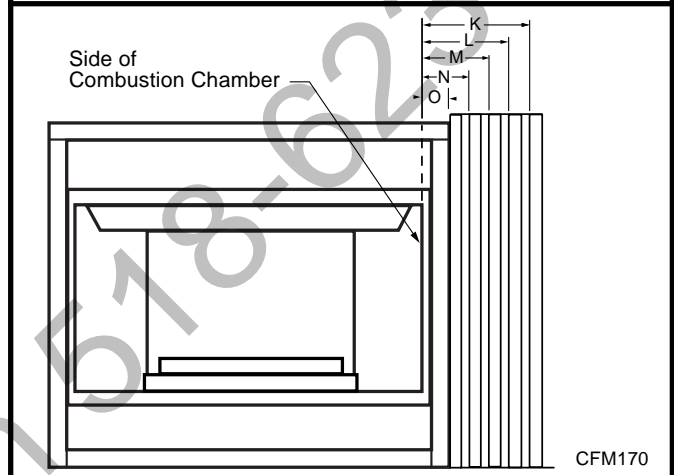
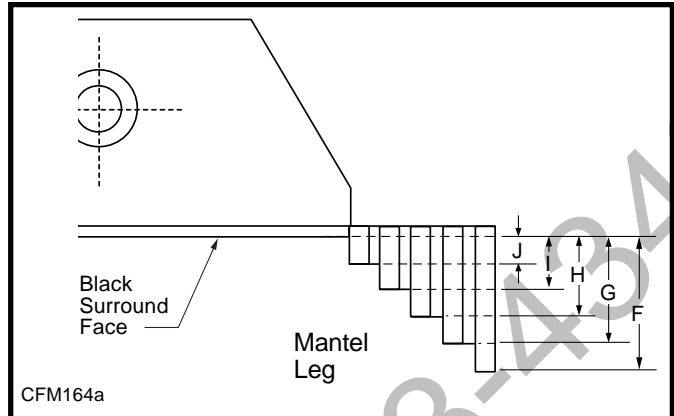

Fig. 4a Combustible mantel minimum installation.



Ref.	Mantel Leg Depth	Ref.	Mantel Leg from Side of Comb. Opening
F	10" (254mm)	K	11½" (292mm)
G	8" (203mm)	L	9½" (241mm)
H	6" (152mm)	M	7½" (191mm)
I	4" (101mm)	N	5½" (140mm)
J	2" (51mm)	O	3½" (89mm)

Fig. 4b Combustible mantel leg minimum installation.

Hearth

A hearth is not mandatory, but is recommended for aesthetic purposes. We recommend a noncombustible hearth which projects out 12" (305mm) or more from the front of the fireplace.

Cold climate installation recommendation:



When installing this unit against a non-insulated exterior wall or chase, it is mandatory that the outer walls be insulated to conform to applicable insulation codes.

Framing And Finishing



Check fireplace to make sure it is levelled and properly positioned.

To mount the appliance:

1. Choose the location.
2. Nailing flanges are supplied with the fireplace (found on the fireplace hearth). To level the box and secure it firmly in place, remove the nailing flanges from the hearth and install at the sides of the fireplace as shown in Figure 5.
3. Screw through the slotted holes in the drywall strip and into pre-drilled holes in fireplace side. Measure from face of fireplace to the face of the drywall strip to confirm the final depth.

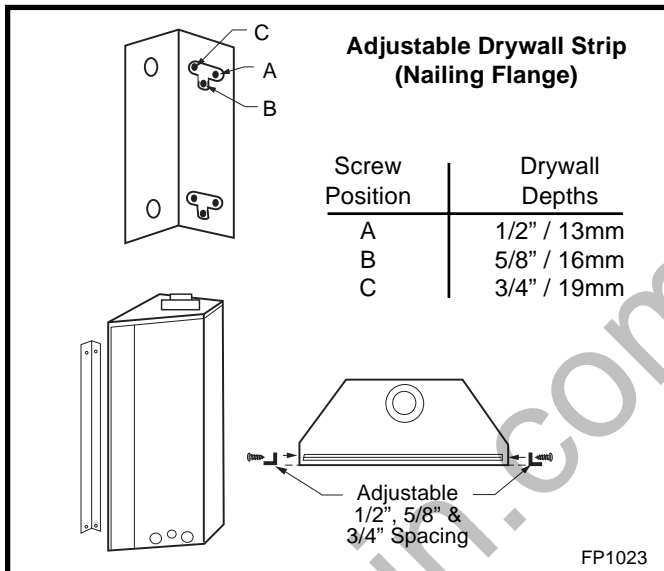

Fig. 5 Adjustable drywall strip (nailing flanges).

Final Finishing

Noncombustible materials such as brick or tile can be extended over the edges of the face of the fireplace. **Do not cover the window frame assembly, any vent, louvre assembly top or louvre assembly bottom.** If a Trim Kit is to be installed, brick and tile will have to be installed flush with the side of this appliance.

Gas Specifications

MODEL	FUEL	GAS CONTROL	MAX. INPUT B.T.U.H	MIN. INPUT B.T.U.H
DV360RN	Natural Gas	Millivolt Hi/Lo	30,000	21,000
DV360RP	Propane	Millivolt Hi/Lo	30,000	21,000
DV360RFN	Natural Gas	Comfort Control	30,000	21,000
DV360RFP	Propane	Comfort Control	30,000	21,000
DV580RN	Natural Gas	Millivolt Hi/Lo	38,000	26,500
DV580RP	Propane	Millivolt Hi/Lo	38,000	27,000
DV580RFN	Natural Gas	Comfort Control	38,000	26,500
DV580RFP	Propane	Comfort Control	38,000	27,000

Gas Inlet and Manifold Pressures

	Natural	LP (Propane)
Minimum Inlet Pressure	5.5" w.c.	11.0" w.c.
Maximum Inlet Pressure	14.0" w.c.	14.0" w.c.
Manifold Pressure	3.5" w.c.	10.0" w.c.

DV360 / DV580

Certified To

ANSI Z21.88-2002/CSA 2.33-M-99
Vented Gas Fireplace Heater

High Elevations

Input ratings are shown in BTU per hour and are certified without deration for elevations up to 4,500 feet (1,370m) above sea level.

For elevations above 4,500 feet (1,370m) in USA, installations must be in accordance with the current ANSI Z223.1/NFPA 54 and/or local codes having jurisdiction.

In Canada, please consult provincial and/or local authorities having jurisdiction for installations at elevations above 4,500 feet (1,370m).

Gas Line Installation



When purging gas line the front glass must be removed.

The gas pipeline can be brought in through the right side of the appliance. Knockouts are provided at convenient locations to allow for the gas pipe installation and testing of any gas connection.

The gas line connection can be made with properly tinned 3/8" copper tubing, 1/2" rigid pipe or an approved flex connector. Since some municipalities have additional local codes, it is always best to consult your local authority and the **CSA-B149.1** installation codes. For USA installations consult the current National Fuel Gas Code, **ANSI Z223.1/NFPA 54**.

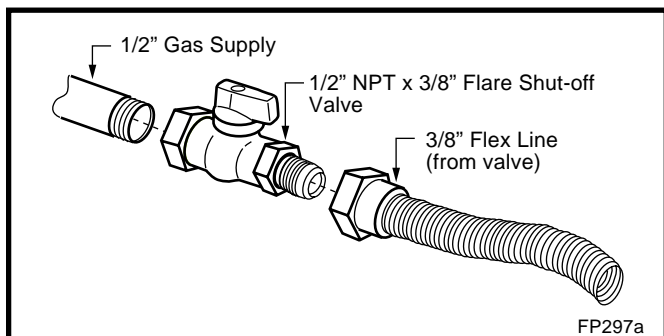

Fig. 6 Typical gas supply installation.

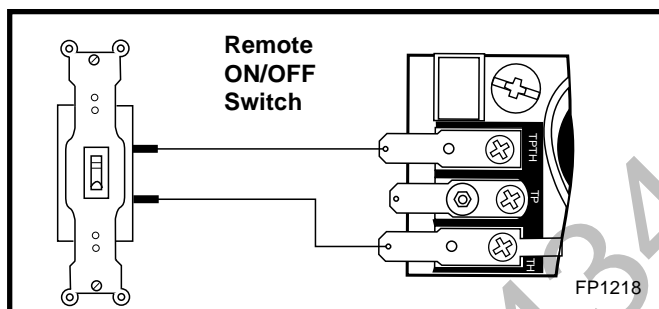

Fig. 7 Remote switch wiring diagram for R models.



Always check for gas leaks with a mild soap and water solution applied with a brush no larger than 1" (25mm). Never apply soap and water solution with a spray bottle. Do not use an open flame for leak testing.



The fireplace valve must not be subjected to any test pressures exceeding 1/2 psi. Isolate or disconnect this or any other gas appliance control from the gas line when pressure testing.

The gas control is equipped with a captured screw type pressure test point, therefore it is not necessary to provide a 1/8" test point up stream of the control.

When using copper or flex connector use only approved fittings. Always provide a union when using black iron pipe so that the gas line can be easily disconnected for burner or fan servicing. (Fig. 6) See the gas specifications for pressure details and ratings.

Alternate Switch Location

The remote switch can be installed either side of the access door. Mount the switch to the switch bracket provided. Screw the bracket on either side of the frame, line up the screws with the prepunched holes. (Fig. 8)

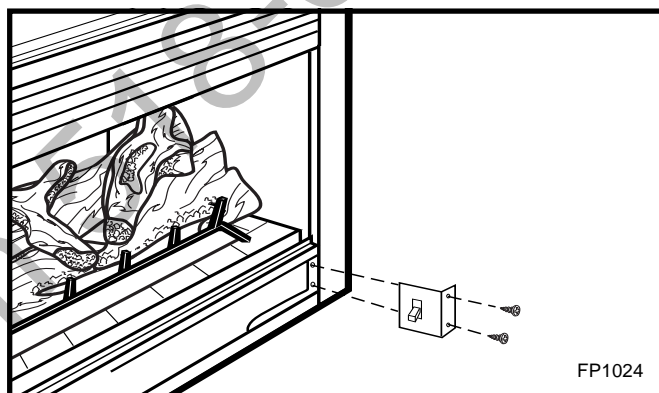

Fig. 8 Alternate switch location.

Remote ON/OFF Switch Installation



Do not wire the remote ON/OFF wall switch for this gas appliance into a 120v power supply.

1. Thread wire through the electrical knockout located on either side of the unit. Take care not to cut the wire or insulation on metal edges. Ensure the wire is secured and protected from possible damage. Run one end of the gas control valve and the other end to the conveniently located wall switch.
2. Attach the wire to the ON/OFF switch and install switch into receptacle box. Attach cover plate to switch.
3. Connect wiring to gas valve. (Fig. 7)

EB-1 Electrical Box



The fireplace, when installed, must be electrically connected and grounded in accordance with local codes or, in the absence of local codes, with the current CSA C22.1 Canadian Electrical Code.



For USA installations, follow the local codes and the national Electrical Code ANSI/NFPA No. 70.



It is strongly suggested that the wiring of the EB-1 Electrical Junction Box be carried out by a licensed electrician.



Ensure that the power to the supply line has been disconnected before commencing this procedure.

The EB-1 electrical junction box has been supplied standard on the DV360/580 models to allow for the easy installation of an optional fan kit.

To connect the EB-1 box to the house electrical supply, follow the steps below.

1. Unscrew the retaining screw from the EB-1 base plate (Fig. 9) and remove the EB-1 assembly from the fireplace.
2. Remove the front cover of the EB-1 box.
3. Remove the plug socket assembly from the EB-1 box.
4. Feed the supply line in from the outside through the cable clamp. (Fig. 9)
5. Connect black wire of the power supply line to the brass screw (polarized) of the socket assembly.
6. Connect the white wire of the power line to the chrome screw of the socket assembly.
7. Connect the ground wire of the supply line to the green screw of the socket assembly.
8. Refit the socket assembly back into the electrical box and replace the cover plate. Secure the cable with the clamp on the outside of the unit to prevent strain on the connections.
9. The EB-1 electrical junction box is now ready to supply power to the FK12 or FK24 fan kits if fitted.

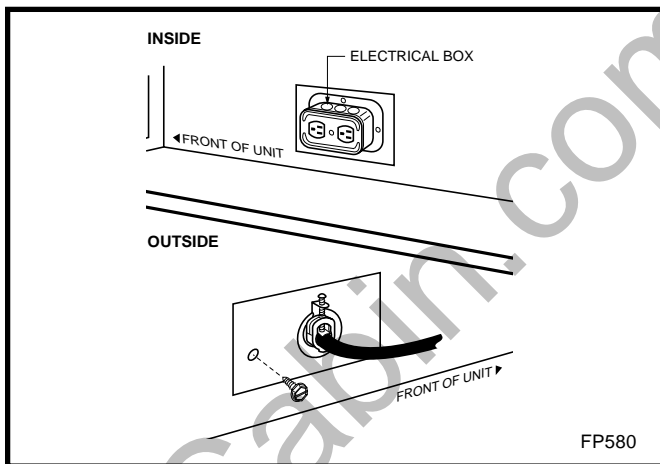

Fig. 9 EB-1 receptacle.

Optional Top Vent Application

The DV360/580 fireplace is shipped as a rear vent unit. If the layout requires a top vent, convert the unit following the steps below.

1. Remove the 10 screws securing outer collar adapter to fireplace. (Fig. 10)
2. Set outer collar adapter aside.
3. Remove insulation from top of unit and discard. Remove the four (4) screws securing flue cover to top of unit and remove flue cover. (Fig. 11)

DV580 Unit ONLY: Remove deflector top from unit

by squeezing together the two legs and allowing top to fall into firebox. Discard. (Fig. 12)

4. Remove the four (4) screws securing flue pipe to back of unit. Remove flue pipe. (Fig. 11)
5. Secure flue cover to back of flue outlet. Be sure to replace gasket. (Fig. 13)
6. Install flue pipe and gasket removed in step 4 to top of unit with four (4) screws. Be sure to replace gasket. (Fig. 13)
7. Secure outer collar adapter to unit with the round collar on top, secure with 10 screws.

NOTE: Be sure not to damage any gasket material.

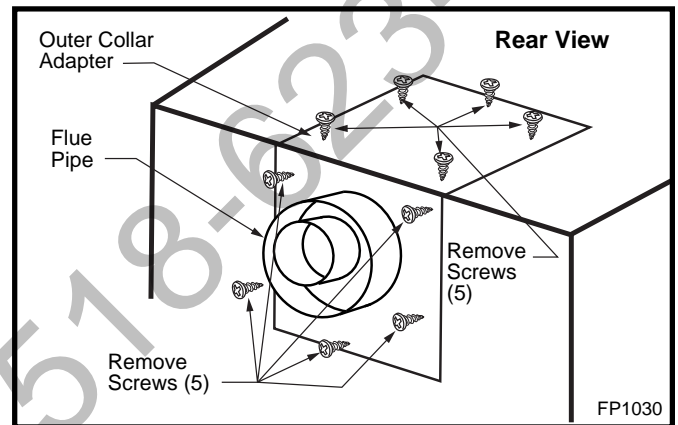

Fig. 10 Remove screws from outer collar adapter.

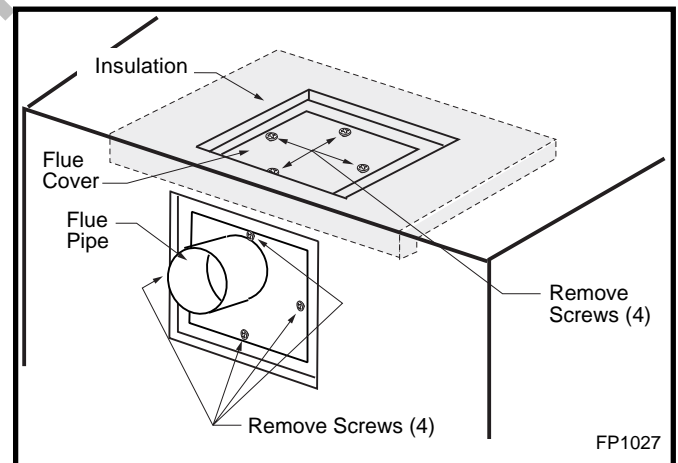

Fig. 11 Remove flue cover and flue pipe.

CAUTION: Remove insulation. Insulation extends beyond opening in top of unit. Be sure to remove all insulation before completing conversion. Insulation measures 9 1/4" x 22 3/4" (23.5cm x 57.8cm). If the unit is converted back to a rear vent, the insulation (Part number 20003129) must be replaced.



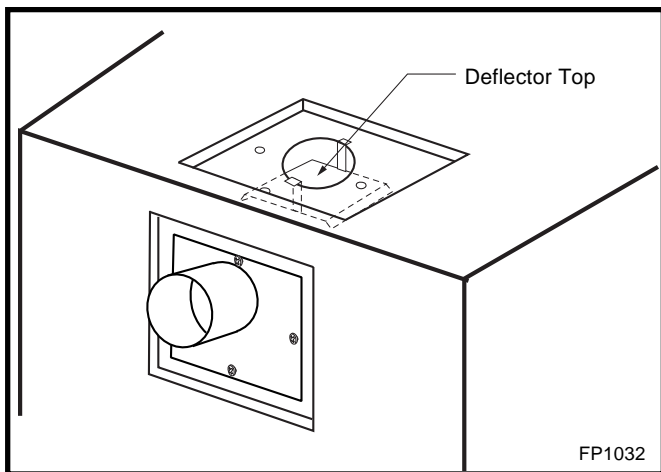

Fig. 12 DV580 only, remove deflector top.

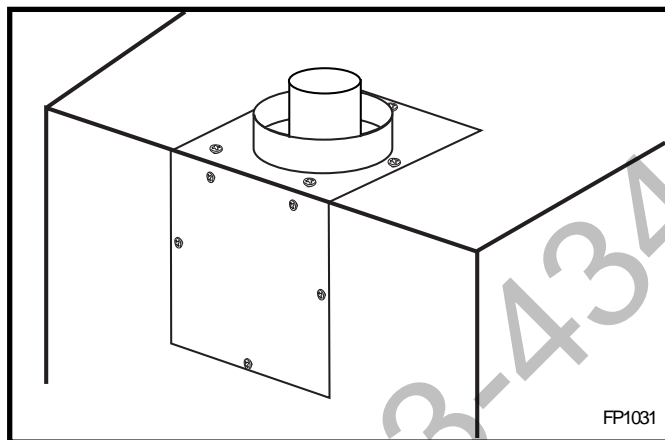

Fig. 14 Completed conversion.

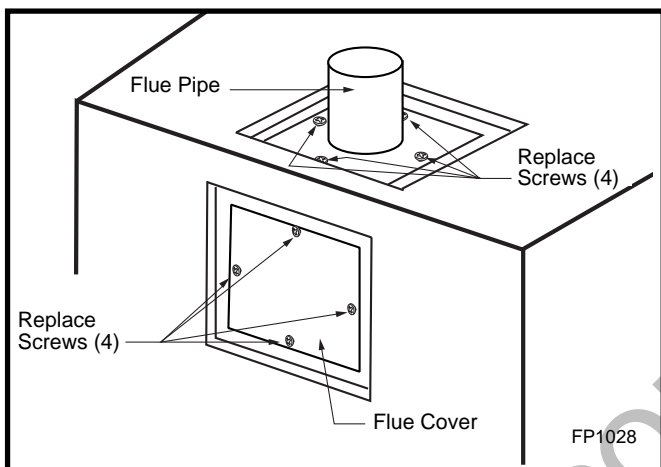

Fig. 13 Replacing flue cover and flue pipe.



After conversion to top vent configuration, the 4" (102mm) flue pipe should be concentric within the 7" (175mm) outer collar.

General Venting

Your fireplace is approved to be vented either through the side wall, or vertical through the roof.

- **Only Vermont Castings, Majestic Products venting components specifically approved and labelled for this fireplace may be used.**
- Venting terminals shall not be recessed into a wall or siding.
- Horizontal venting must be installed on a level plane without an inclining or declining slope.

There must not be any obstruction such as bushes, garden sheds, fences, decks or utility buildings within 24" (610mm) from the front of the termination hood.

Do not locate termination hood where excessive snow or ice build up may occur. Be sure to check vent termination area after snow falls, and clear to prevent accidental blockage of venting system. When using snow blowers, make sure snow is not directed towards vent termination area.

Location of Vent Termination

It is imperative the vent termination be located observing the minimum clearances as shown on following page.

General Venting Information - Termination Location

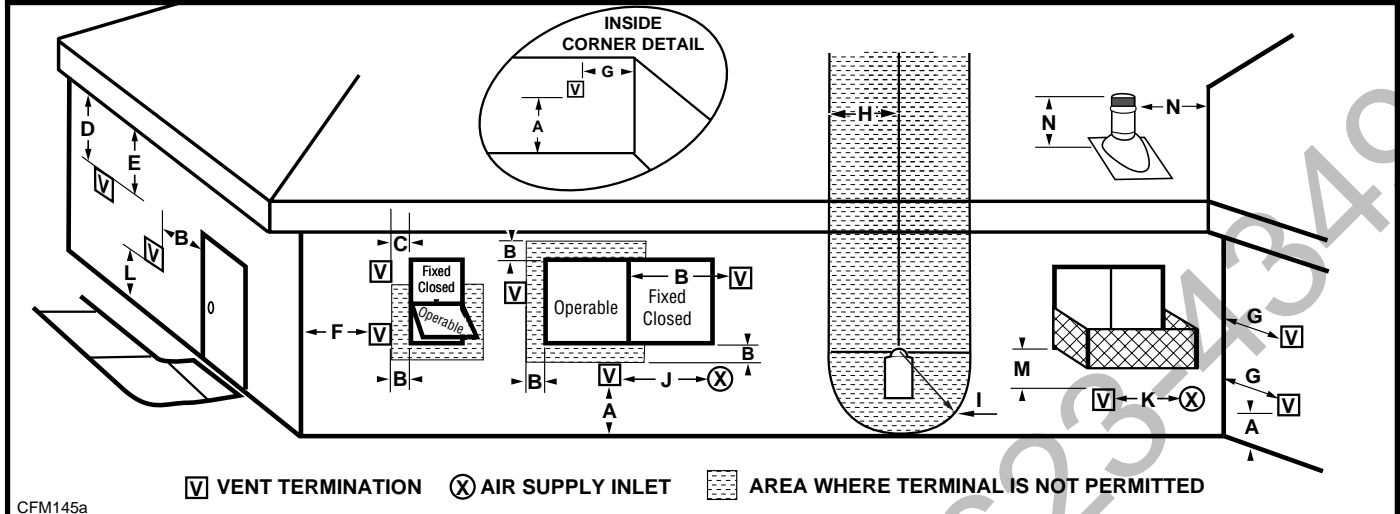

	Canadian Installations ¹	US Installations ²
A = Clearance above grade, veranda, porch, deck, or balcony	12" (30cm)	12" (30cm)
B = Clearance to window or door that may be opened	6" (15cm) for appliances < 10,000 Btuh (3kW), 12" (30cm) for appliances > 10,000 Btuh (3kW) and < 100,000 Btuh (30kW), 36" (91cm) for appliances > 100,000 Btuh (30kW)	6" (15cm) for appliances < 10,000 Btuh (3kW), 9" (23cm) for appliances > 10,000 Btuh (3kW) and < 50,000 Btuh (15kW), 12" (30cm) for appliances > 50,000 Btuh (15kW)
C = Clearance to permanently closed window	12" (305mm) recommended to prevent window condensation	12" (305mm) recommended to prevent window condensation
D = Vertical clearance to ventilated soffit located above the terminal within a horizontal distance of 2 feet (610mm) from the center line of the terminal	18" (458mm)	18" (458mm)
E = Clearance to unventilated soffit	12" (305mm)	12" (305mm)
F = Clearance to outside corner	see next page	see next page
G = Clearance to inside corner (see next page)	see next page	see next page
H = Clearance to each inside of center line extended above meter/regulator assembly	3' (91cm) within a height of 15' above the meter/regulator assembly	3' (91cm) within a height of 15' above the meter/regulator assy
I = Clearance to service regulator vent outlet	3' (91cm)	3' (91cm)
J = Clearance to nonmechanical air supply inlet to building or the combustion air inlet to any other appliances	6" (15cm) for appliances < 10,000 Btuh (3kW), 12" (30cm) for appliances > 10,000 Btuh (3kW) and < 100,000 Btuh (30kW), 36" (91cm) for appliances > 100,000 Btuh (30kW)	6" (15cm) for appliances < 10,000 Btuh (3kW), 9" (23cm) for appliances > 10,000 Btuh (3kW) and < 50,000 Btuh (15kW), 12" (30cm) for appliances > 50,000 Btuh (15kW)
K = Clearance to a mechanical air supply inlet	6' (1.83m)	3' (91cm) above if within 10' (3m) horizontally
L = Clearance above paved sidewalk or paved driveway located on public property	7' (2.13m)†	7' (2.13m)†
M = Clearance under veranda, porch, deck or balcony	12" (30cm)‡	12" (30cm)‡
N = Clearance above a roof shall extend a minimum of 24" (610mm) above the highest point when it passes through the roof surface, and any other obstruction within a horizontal distance of 18" (450mm).		

1 In accordance with the current CSA-B149 Installation Codes
 2 In accordance with the current ANSI Z223.1/NFPA 54 National Fuel Gas Codes
 † A vent shall not terminate directly above a sidewalk or paved driveway which is located between two single family dwellings and serves both dwellings
 ‡ only permitted if veranda, porch, deck or balcony is fully open on a minimum 2 sides beneath the floor:
 NOTE: 1. Local codes or regulations may require different clearances.
 2. The special venting system used on Vermont Castings Direct Vent Stoves are certified as part of the appliance, with clearances tested and approved by the listing agency.

Fig. 15 Vent termination clearances.

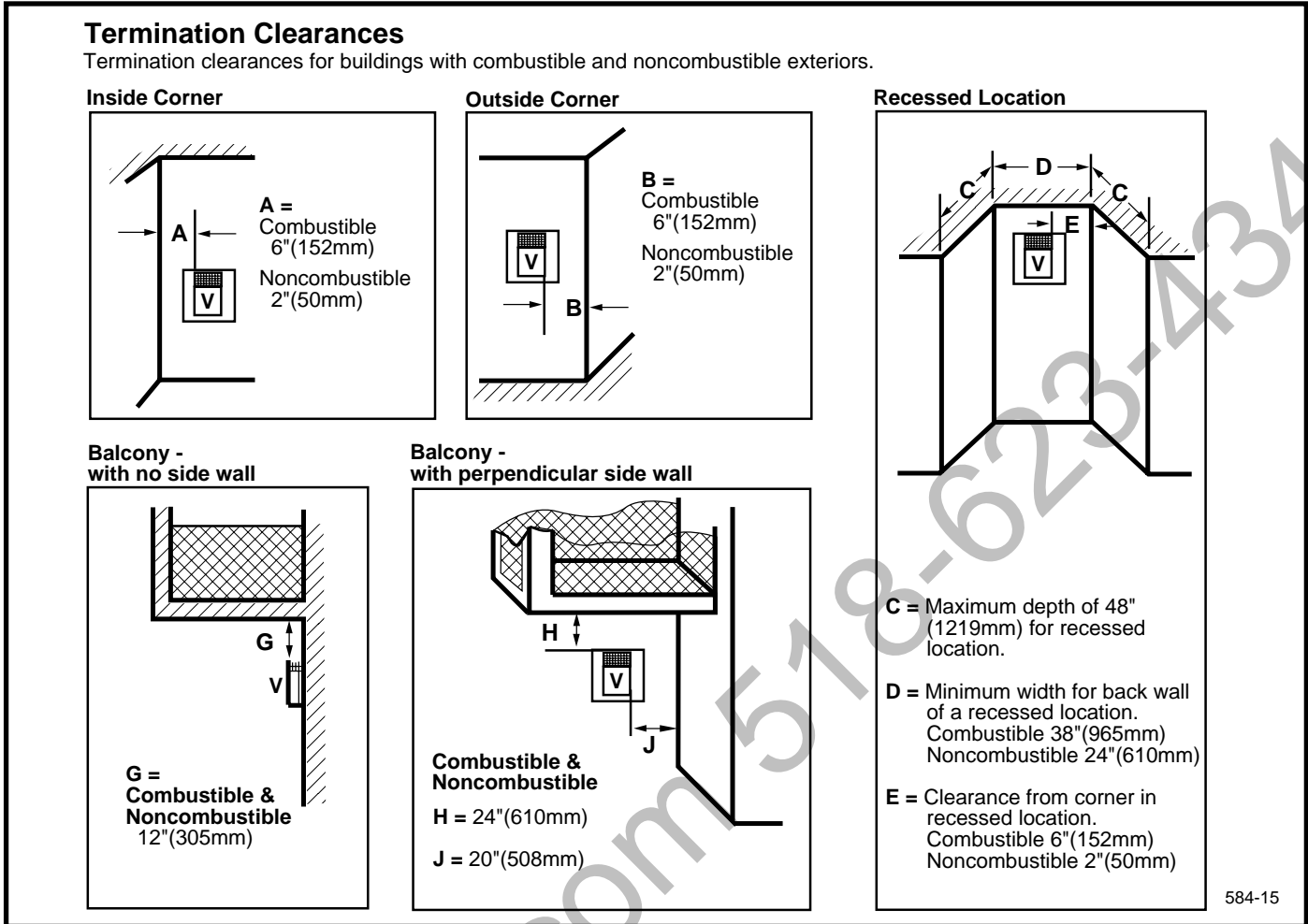

Fig. 16 Termination clearances.

General Information Assembling Vent Pipes

Canadian Installations

The venting system must be installed in accordance with the current CSA-B149.1 installation code.

USA Installations

The venting system must conform to local codes and/or the current National Fuel Code ANSI Z223.1/NFPA 54. Only venting components manufactured by Vermont Castings, Majestic Products may be used in Direct Vent systems.

Twist Lock Pipes

When using Vermont, Castings Majestic Products twist lock pipe it is not necessary to use sealant on the joints. The only areas of the venting system that need to be sealed with high temperature silicone sealant are the collars on the fireplace and termination, and the sliding joint of any telescopic vent section used in the system.

To join twist lock pipes together, simply align the beads of the male end with the grooves of the female end, twisting the pipe until the flange on the female end contacts external flange on the male end. It is recommended that you secure the joints with three (3) sheet metal screws, however, this is not mandatory with twist lock pipe. (Fig. 17)

To make it easier to assembly the joints, we suggest putting a lubricant (Vaseline or similar) on the male end of the twist lock pipe prior to assembly.

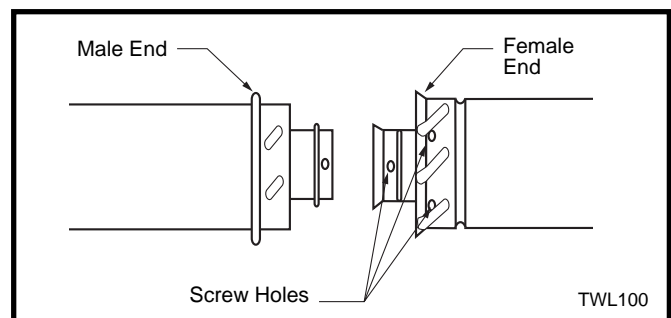

Fig. 17 Twist-Lock pipe joints.

How to Use the Vent Graph

The Vent Graph should be read in conjunction with the following vent installation instructions to determine the relationship between the vertical and horizontal dimensions for the vent system.

1. Determine the height of the center of the horizontal vent pipe exiting through the outer wall. Using this dimension on the Sidewall Vent Graph (Fig. 18), locate the point intersecting with the slanted graph line.
2. From the point of this intersection, draw a vertical line to the bottom of the graph.
3. Select the indicated dimension, and position the fireplace in accordance with same.

EXAMPLE A:

If the vertical dimension from the floor of the unit is 11' (3.4m) the horizontal run to the face of the outer wall must not exceed 14' (4.3m).

EXAMPLE B:

If the vertical dimension from the floor of the unit is 7' (2.1m), the horizontal run to the face of the outer wall must not exceed 8½' (2.6m).

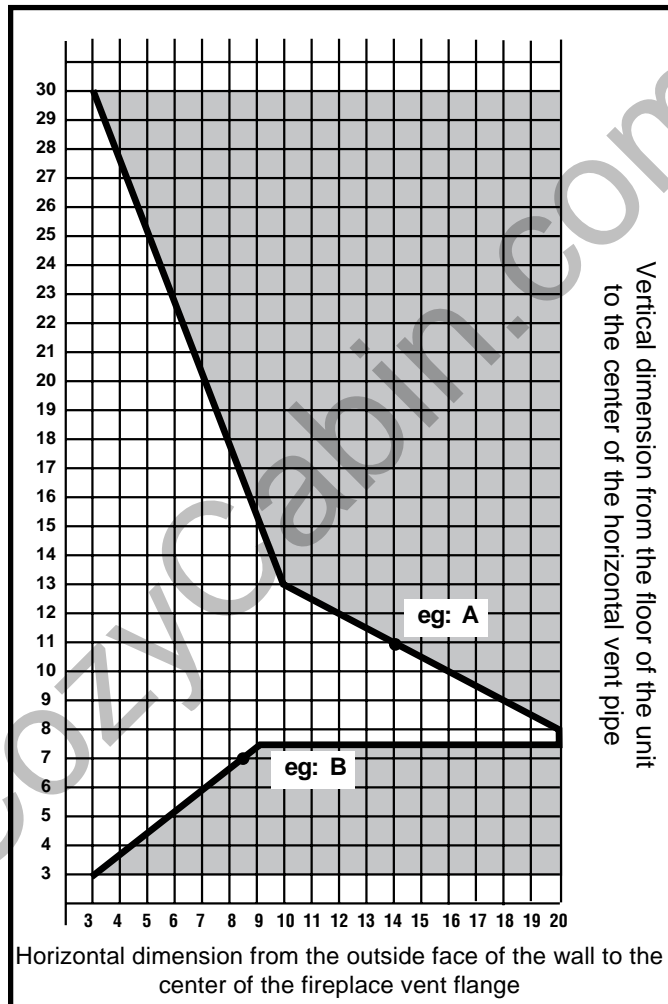

Fig. 18 Sidewall venting graph. (Dimensions in feet.)

20002261 Refer to Page 17 for venting requirements for snorkels.

Rear Wall Vent Applications

When installed as a rear vent unit this appliance may be vented directly to a termination located on the rear wall behind the appliance.

- Only Vermont Castings, Majestic Products venting components are approved to be used in these applications (See 'Venting Components' listed for different installation requirements).
- The maximum horizontal distance between the rear of the appliance (or end of the transition elbow in a corner application) and the outside face of the rear wall is 20" (508mm). (Fig. 19, 20)
- Only one 45° elbow is allowed in these installations.
- Minimum clearances between vent pipe and combustible materials are as follows:

- Top - 2" (51 mm)
- Sides - 1" (25 mm)
- Bottom - 1" (25 mm)

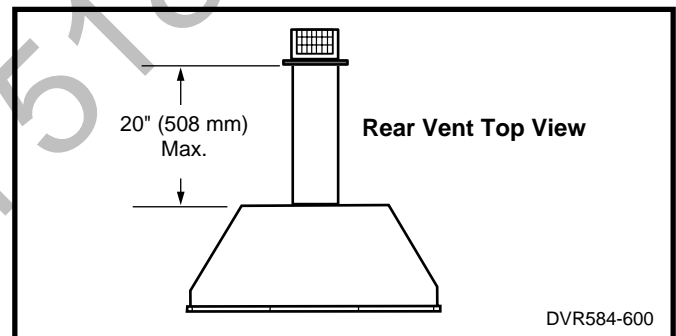

Fig. 19 Rear vent application, no elbows.

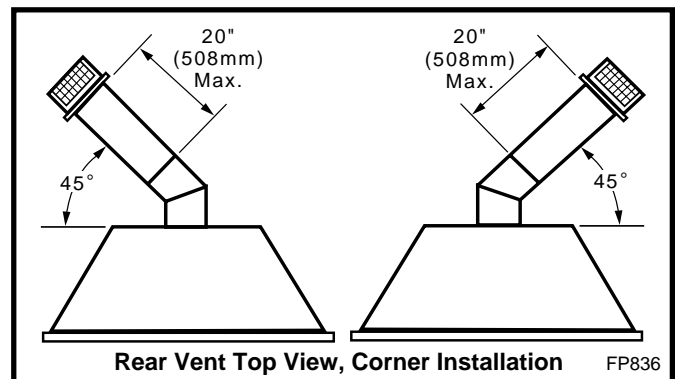

Fig. 20 Rear vent application, one 45° elbow.

Rear Wall Vent Installations

Step 1

Locate and cut the vent opening in the wall.
For combustible walls first frame in opening. (Fig. 21)

Combustible Walls: Cut a 10 $\frac{3}{8}$ "H x 9 $\frac{3}{8}$ " W (265mm x 240mm) hole through the exterior wall and frame as shown. (Fig. 21)

Noncombustible Walls: Hole opening should be 7 $\frac{1}{2}$ " (191mm) diameter.



Zero clearance sleeve is only required for combustible walls.

Step 2

Measure wall thickness and cut zero clearance sleeve parts to proper length (Maximum 12" / 305mm). Assemble sleeve to its maximum opening (10 $\frac{3}{8}$ " x 9 $\frac{3}{8}$ ") and attach to firestop assembly. (Fig. 22)

Step 3

Measure the horizontal length requirement for the venting including a 2" (51mm) overlap, i.e. from the elbow to the outside wall face plus 2" (51mm). (Fig. 20)

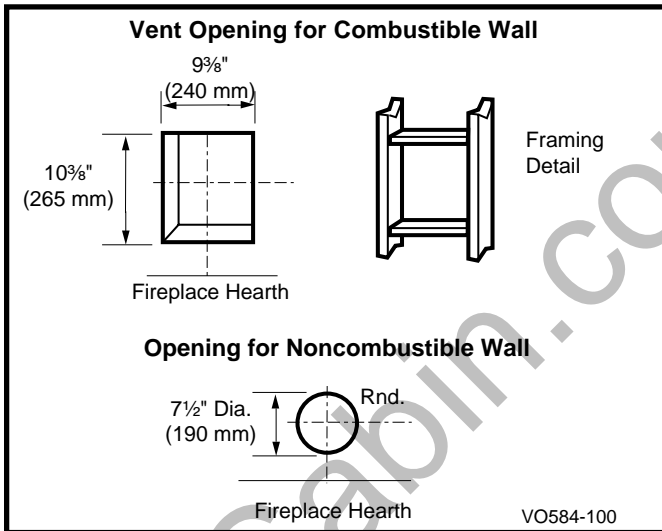

Fig. 21 Locate vent opening on wall.

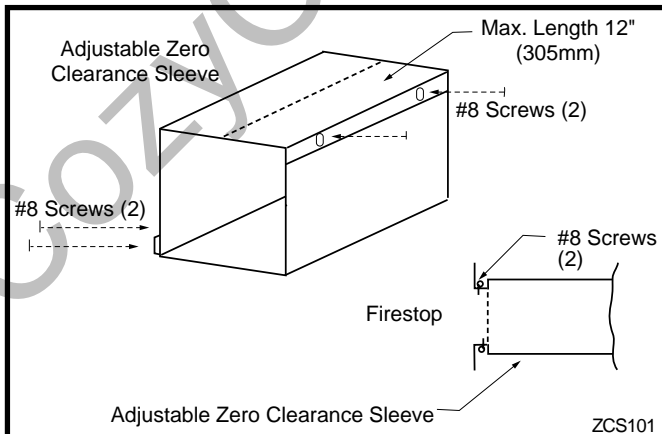

Fig. 22 Adjustable zero clearance sleeve.

Step 4

Install the 4" (102mm) vent to the appliance collar and secure with 3 sheet metal screws. Install the 7" (178mm) vent pipe to the appliance collar and secure with 3 sheet metal screws. It is not necessary to seal this connection. If a 45° elbow is being used attach the elbow to the appliance in the same manner then attach the venting to the elbow.



It is critical that there is no downward slope away from the appliance when connecting the vent or elbow.

Step 5

Guide the venting through the vent hole as you place the appliance in its installed position. Guide the 4" (102mm) and 7" (178mm) collar of the vent termination into the outer ends of the venting. Do not force the termination. If the vent pipes do not align with the termination, remove and realign the venting at the appliance flue collars. (Fig. 23) Attach the termination to the wall as outlined in the instruction sheet supplied with the termination.

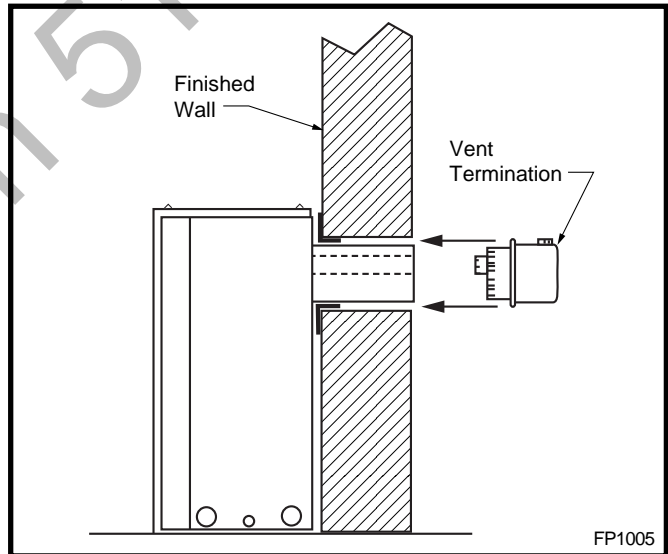

Fig. 23 Side view of final unit location.

Vertical Sidewall Applications

Since it is very important that the venting system maintain its balance between the combustion air intake and the flue gas exhaust, certain limitations as to vent configurations apply and must be strictly adhered to.

The Vent Graph, showing the relationship between vertical and horizontal side wall venting, will help to determine the various dimensions allowable.

Minimum clearance between vent pipes and combustible materials is one inch (25mm) on top, bottom and sides unless otherwise noted.

When vent termination exits through foundations less than 20" (508mm) below siding outcrop, the vent pipe must flush up with the siding.

It is best to locate the fireplace in such a way that minimizes the number of offsets and horizontal vent length.

The horizontal vent run refers to the total length of vent pipe from the flue collar of the fireplace (or the top of the Transition Elbow) to the face of the outer wall.

Horizontal plane means no vertical rise exists on this portion of the vent assembly.



When installing the appliance as a rear vent unit, the 90° or 45° Transition Elbow attached directly to the rear of the unit is NOT INCLUDED in the following criteria and calculations, and unless specifically mentioned should be ignored when calculating venting layouts.

- The maximum number of 90° elbows per side wall installation is three (3). (Fig. 24)
- If a 90° elbow is fitted directly on top of the fireplace flange the maximum horizontal vent run before the termination or a vertical rise is 36" (914mm). (Fig. 25)
- If a 90° elbow is used in the horizontal vent run (level height maintained) the horizontal vent length is reduced by 36" (914mm). (Fig. 26 & 27) This does not apply if the 90° elbows are used to increase or redirect a vertical rise. (Fig. 24)

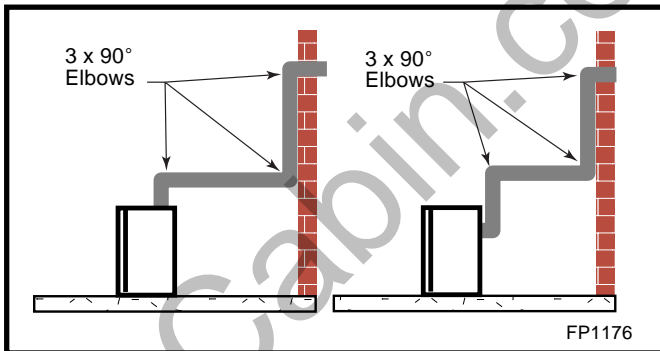

Fig. 24 Maximum three (3) 90° elbows per installation.

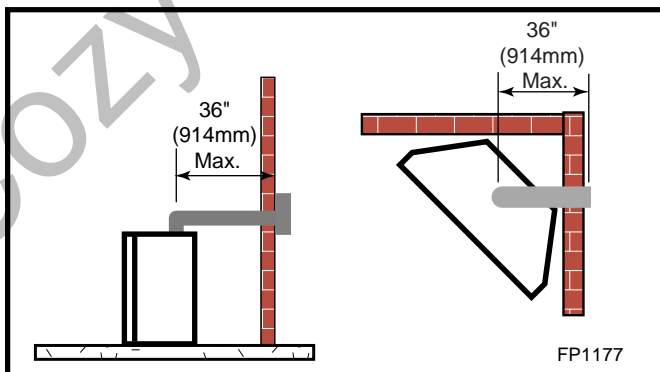

Fig. 25 Maximum horizontal run with no rise.

Example: According to the vent graph (Page 13) the maximum horizontal vent length in a system with a 7½' (2.3m) rise is 20' (6m) and if a 90° elbow is required in the horizontal vent it must be reduced to 17' (5.2m). In Figure 26 & 27, dimension A plus B must not be greater than 17' (5.2m)

- The maximum number of 45° elbows permitted per side wall installation is two (2). These elbows can be installed in either the vertical or horizontal run.
- For each 45° elbow installed in the horizontal run, the length of the horizontal run MUST be reduced by 18" (457mm). This does not apply if the 45° elbows are installed on the vertical part of the vent system.
- The maximum number of elbow degrees in a system is 270°. (Fig. 28)

Example:

Elbow 1	=	90°
Elbow 2	=	45°
Elbow 3	=	45°
Elbow 4	=	90°

Total angular variation = 270°

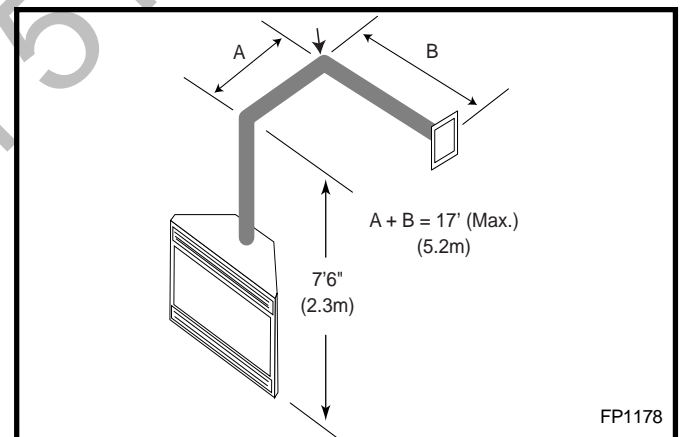

Fig. 26 Horizontal run reduction.

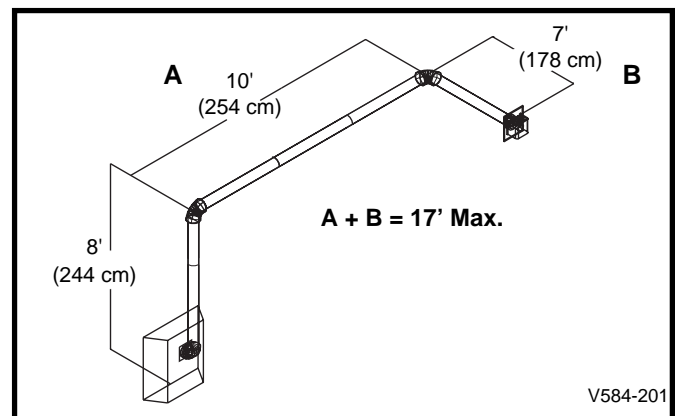

Fig. 27 Maximum vent run with elbows.

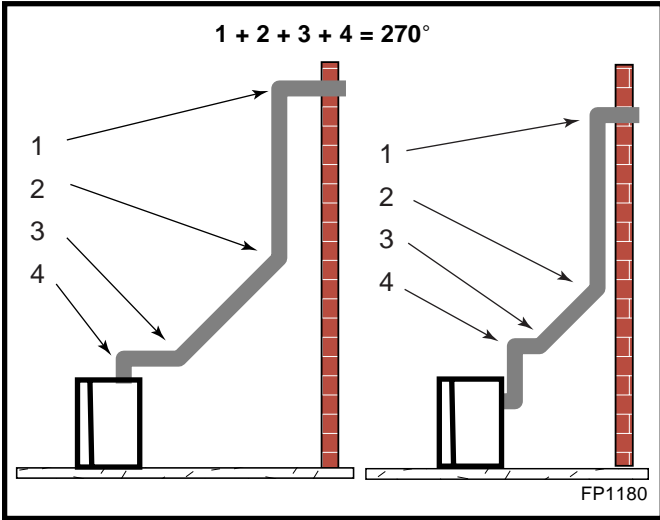

Fig. 28 Maximum elbow usage.

Vertical Sidewall Installation

Step 1

Locate vent opening on the wall. It may be necessary to first position the fireplace and measure to obtain hole location. Depending on whether the wall is combustible or noncombustible, cut opening to size. (Fig. 29) (For combustible walls first frame in opening.)

Combustible Walls: Cut a 9 $\frac{3}{8}$ "H x 9 $\frac{3}{8}$ "W (240mm x 240mm) hole through the exterior wall and frame as shown. (Fig. 29)

Noncombustible Walls: Hole opening must be 7 $\frac{1}{2}$ " (191mm) in diameter.

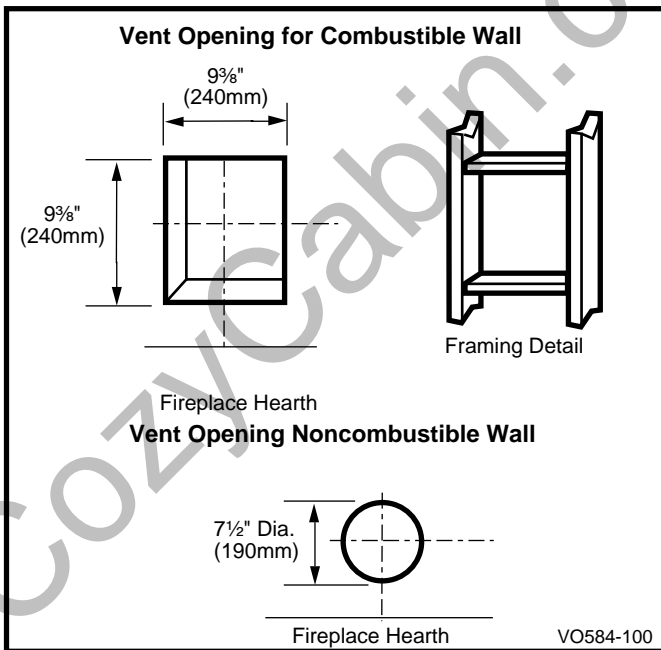

Fig. 29 Locate vent opening on wall.

Step 2

Measure wall thickness and cut zero clearance sleeve parts to proper length (MAXIMUM 12" / 305mm). Assemble sleeve and attach to firestop with #8 sheet metal screws (supplied). Install firestop assembly. (Fig. 30)



Zero clearance sleeve is only required for combustible walls.

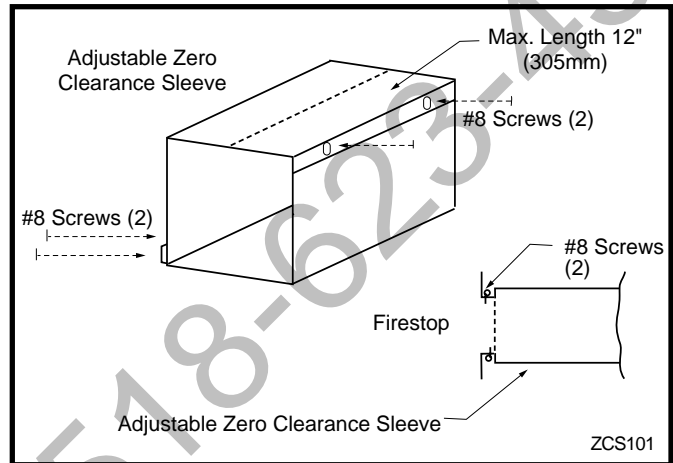

Fig. 30 Adjustable zero clearance sleeve.

Step 3

Place fireplace into position. Measure the vertical height (X) required from the base of the flue collars to the center of the wall opening. (Fig. 31)

Step 4

Apply a band of silicone to the inner and outer flue collars of the fireplace and using appropriate length of pipe section(s) attach to fireplace with three (3) screws. Follow with the installation of the inner and outer elbow, again secure joints with three (3) sheet metal screws. Wipe off any excess high temperature sealant.

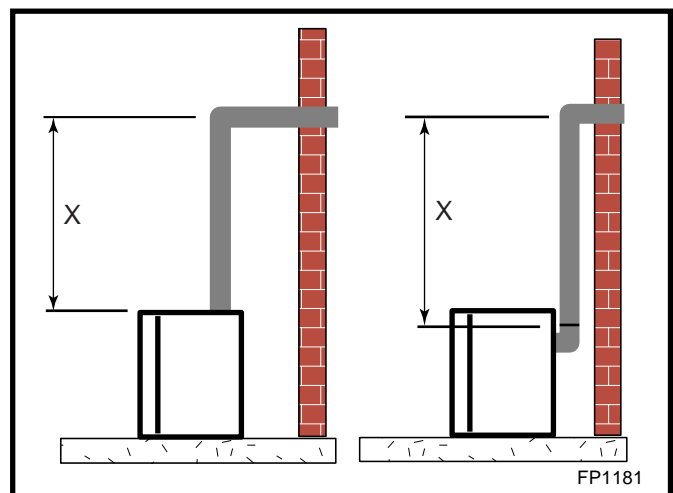

Fig. 31 Vertical height requirements.

Step 5

Measure the horizontal length requirement including a 2" (51mm) overlap, i.e. from the elbow to the outside wall face plus 2" (51mm) (or the distance required if installing a second 90° elbow). (Fig. 32)



Always install horizontal venting on a level plane.

Step 6

Use appropriate length of pipe sections - telescopic or fixed - and install. The sections which go through the wall are packaged with the starter kit, and can be cut to suit if necessary.

Sealing vent pipe and firestop gaps with high temperature sealant will restrict cold air being drawn in around fireplace.

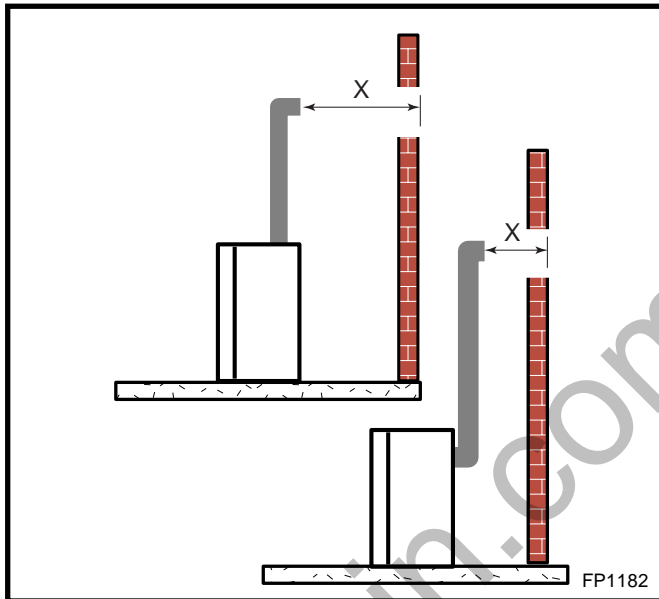

Fig. 32 Horizontal length requirement.

Step 7

Apply high temperature sealant to 4" (102mm) and 7" (178mm) collars or the termination one inch away from crimped end. Guide the vent terminations 4" and 7" collar into their respective vent pipes. Double check that the vent pipes overlap the collars by 2" (51mm). Secure the termination to the wall with screws provided and caulk around the wall plate to weatherproof. As an alternative to screwing the termination directly to the wall, you may also use expanding plugs or an approved exterior construction adhesive. You may also attach the termination with screws through the inner body into the 4" vent pipe, however for this method, you must extend the 4" pipe approximately 6" (152mm) beyond the outer face of the wall.



Support horizontal pipes every 36" (914mm) with metal pipe straps.

Below Grade Installation

When it is not possible to meet the required vent terminal clearances of 12" (305mm) above grade level, a snorkel kit is recommended. It allows installation depth down to 7" (178mm) below grade level. The 7" (178mm) is measured from the center of the horizontal vent pipe as it penetrates through the wall.

Ensure the sidewall venting clearances are observed. If venting system is installed below ground, we recommend a window well with adequate and proper drainage to be installed around the termination area.

If installing a snorkel, a minimum 24" (610mm) vertical rise is necessary. The maximum horizontal run with the 24" vertical pipe is 36" (914mm). This measurement is taken from the collar of the fireplace (or transition elbow) to the face of the exterior wall. See the Sidewall Venting Graph for extended horizontal run if the vertical exceeds 24" (610mm).

1. Establish vent hole through the wall (Fig. 29)
2. Remove soil to a depth of approximately 16" (406mm) below base of snorkel. Install drain pipe. Install window well (not supplied). Refill hole with 12" (305mm) of coarse gravel leaving a clearance of approximately 4" (102mm) below snorkel. (Fig. 33)
3. Install vent system.
4. Ensure a watertight seal is made around the vent pipe coming through the wall.
5. Apply high temperature sealant caulking (supplied) around the 4" and 7" snorkel collars.
6. Slide the snorkel into the vent pipes and secure to the wall.
7. Level the soil so as to maintain a 4" (102mm) clearance below snorkel. (Fig. 33)

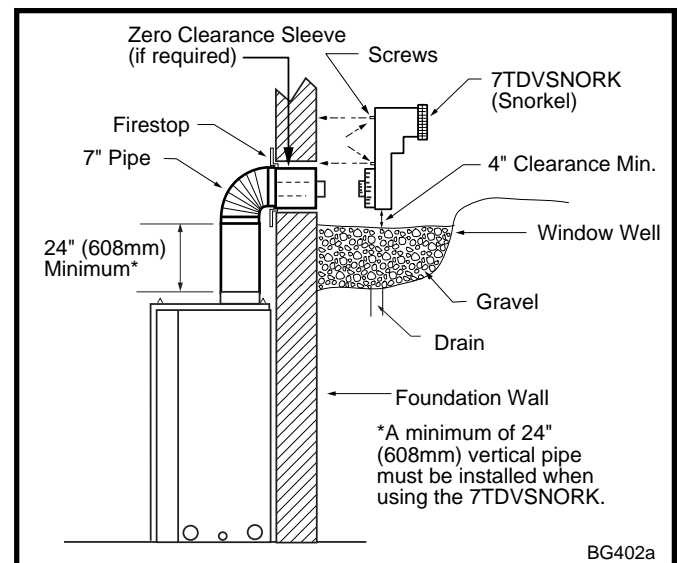

Fig. 33 Below grade installation.



Do not back fill around snorkel.
A clearance of at least 4" must be maintained between the snorkel and the soil.

If the foundation is recessed, use recess brackets (not supplied) for securing lower portion of the snorkel. Fasten brackets to wall first, then secure to snorkel with self drilling #8 x 1/2 sheet metal screws. It will be necessary to extend vent pipes out as far as the protruding wall face. (Fig. 34)

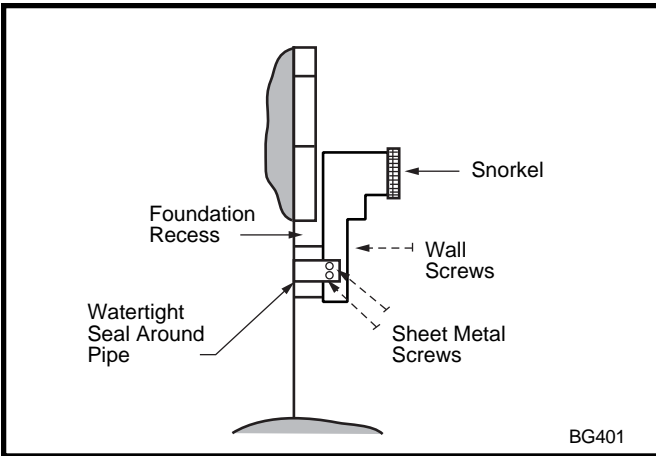

Fig. 34 Snorkel installation, recessed foundation.

Vertical Through-the-Roof Applications

This gas fireplace has been approved for:

- Vertical installations up to 40' (12m) in height. Up to a 10' (3m) horizontal vent run can be installed within the vent system using a maximum of two 90° elbows. (Fig. 35)
- Up to two 45° elbows may be used within the horizontal run. For each 45° elbow used on the horizontal plane, the maximum horizontal length must be reduced by 18" (450mm).

Example: Maximum horizontal length:

No elbows	=	10' (3m)
1 x 45° elbow	=	8.5' (2.6m)
2 x 45° elbows	=	7' (2.1m)

- A minimum of an 8' (2.5m) vertical rise is required.
- Two sets of 45° elbow offsets may be used within the vertical sections. From 0 to a maximum of 8' (2.5m) of vent pipe can be used between elbows. (Fig. 36)
- 7DVCS supports offsets. (Fig. 38) This application will require that you first determine the roof pitch and use the appropriate starter kit. (Refer to Venting Components List)
- The maximum angular variation allowed in the system is 270°. (Fig. 36)
- The minimum height of the vent above the highest point of penetration through the roof is 2' (610mm). (Fig. 39) Refer to note 2, Page 13.

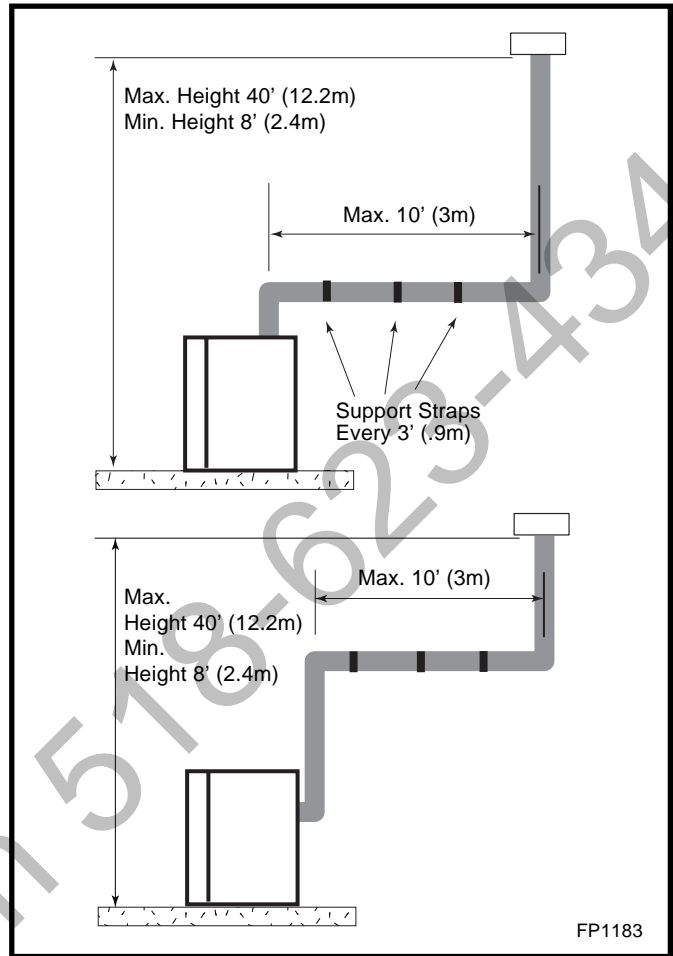

Fig. 35 Support straps for horizontal runs.

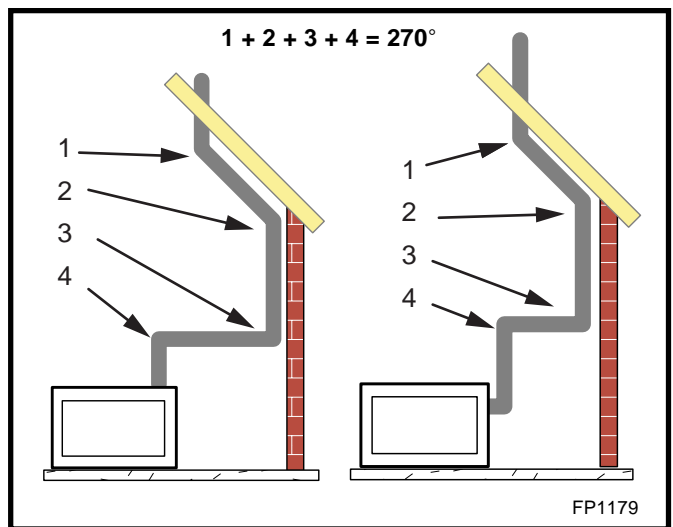

Fig. 36 Maximum elbow usage.

Vertical Through-the-Roof Installation

1. Locate your fireplace.
2. Plumb to center of the (4") flue collar from ceiling above and mark position.
3. Cut opening equal to $9\frac{3}{8}" \times 9\frac{3}{8}"$ (240mm x 240mm).
4. Proceed to plumb for additional openings through the roof. In all cases, the opening must provide a minimum of 1 inch clearance to the vent pipe, i.e., the hole must be at least $9\frac{3}{8}" \times 9\frac{3}{8}"$ (240mm x 240mm).
5. Place fireplace into position.
6. Place firestop(s) #7DVFS or Attic Insulation Shield #7DVAIS into position and secure. (Fig. 37)
7. Install roof support (Fig. 38) and roof flashing making sure upper flange is below the shingles. (Fig. 40)
8. Install appropriate pipe sections until the venting is above the flashing. (Fig. 40)
9. Install storm collar and seal around the pipe.
10. Add additional vent lengths for proper height. (Fig. 39)
11. Apply high temperature sealant to 4" and 7" collars of vertical vent termination and install.

If there is a room above ceiling level, fire stop spacer must be installed on both the bottom and the top side of the ceiling joists. If an attic is above ceiling level a 7DVAIS (Attic Insulation Shield) must be installed.

The enlarged ends of the vent section always face downward.

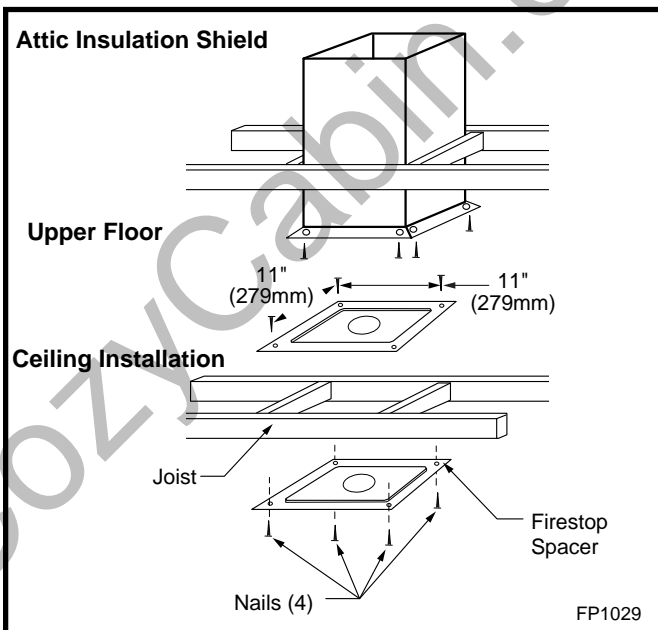

Fig. 37 Place firestop spacer(s) and secure.

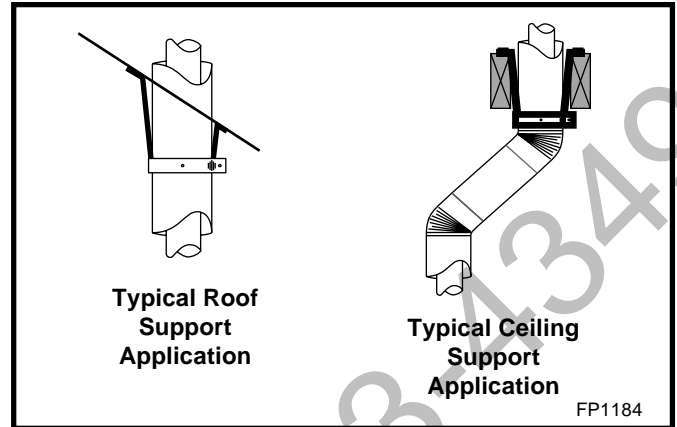

Fig. 38 Venting supports.

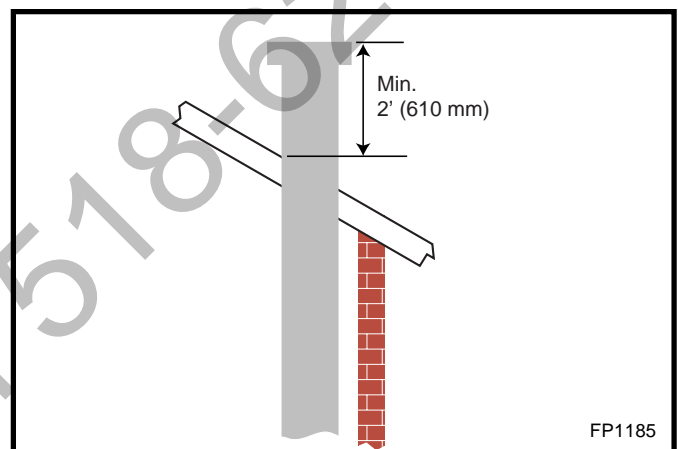

Fig. 39 Minimum termination to roof clearance.

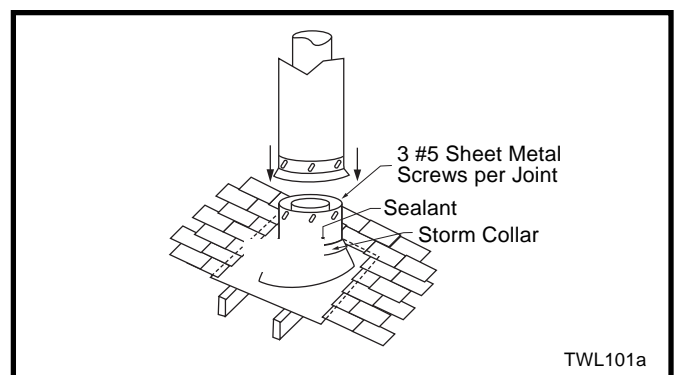
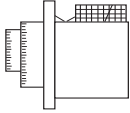
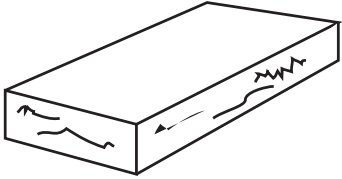
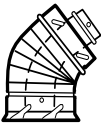
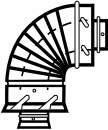
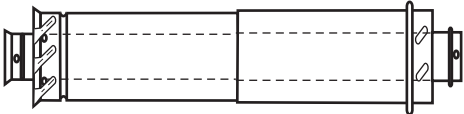
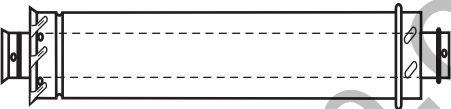
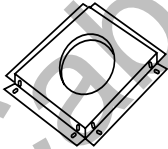
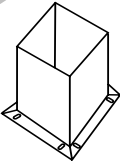
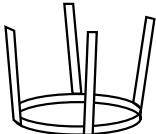

Fig. 40 Roof flashing.

Twist Lock Venting Components	
	7TDVRVT - Through the wall Rear Vent Termination
	Starter Kit - Model 7TDVSK-Sidewall Venting Starter Kit- Model 7TDVSKV-Vertical Venting for 7TDVSKV-A order 1/12 to 6/12 roof pitch for 7TDVSKV-B order 7/12 to 12/12 roof pitch for 7TDVSKV-F order flat roof Starter Kit - Model 7TDVSKS - Snorkel Kit Snorkel Termination - 7TDVSNORK for Below Grade Installation
	45° Elbow 7TDV45 for Rear Vent to Vertical Vent or Vertical/Horizontal Offsets
	90° Transition Elbow 7TDVRT90 for Rear Vent to Vertical Vent 90° Elbow 7TDV90 Vertical/Horizontal Offset
	Telescopic vent sections 7TDVP1218 12" to 18" adjustable length 7TDVP3564 35" to 64" adjustable length
	Pipe sections for vertical or horizontal venting Model 7TDVP8" 4 per box Model 7TDVP12" 4 per box Model 7TDVP24" 4 per box Model 7TDVP36" 4 per box Model 7TDVP48"
	Firestop Spacer Model 7DVFS
	Attic Insulation Shield Model 7DVAIS
	Vertical/Horizontal Combination Offset Support Model 7DVCS

Operating Instructions

Glass Information



Only glass approved by Vermont Castings, Majestic Products should be used on this fireplace.

- The use of any non-approved replacement glass will void all product warranties.
- Care must be taken to avoid breakage of the glass.
- **Do not operate appliance with glass front removed, cracked or broken.**
- **Replacement glass (complete with gasket) is available through your Vermont Castings, Majestic Products dealer and should only be installed by a licensed qualified service person.**

Louvre Removal

To remove louvre assembly top, pull louvre up and then lift out. The louvre assembly bottom is hinged at the bottom edge and swings down. (Fig. 41)

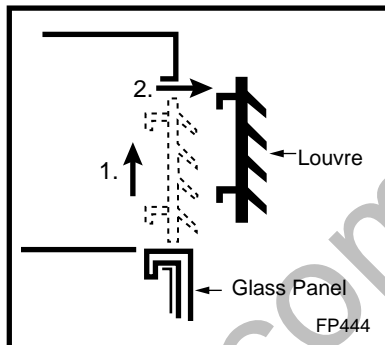

Fig. 41 Remove louvre assembly top.

Window Frame Assembly Removal

1. Turn the fireplace OFF (including the pilot).
2. If the unit has been operating, allow time for the components to cool.
3. Remove louvre assembly top.
4. Open the louvre assembly bottom.
5. Release the two clamps along lower edge of the frame by pulling down on clamp handles. (Fig. 42)
6. Tilt window frame assembly out slightly at the bottom, lift the frame up and away from the fireplace.
7. To replace window frame assembly reverse procedure.

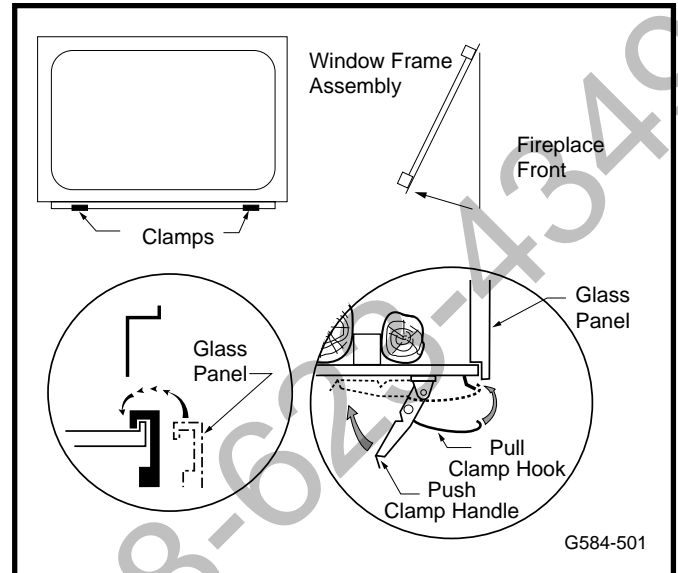

Fig. 42 Window frame assembly removal.

Glass Cleaning

It is necessary to clean the glass periodically. During start-up condensation, which is normal, forms on the inside of the glass and causes lint, dust and other airborne particles to cling to the glass surface. Also initial paint curing may deposit a slight film on the glass. It is therefore recommended the glass be cleaned two or three times with a non-ammonia household cleaner and warm water (gas fireplace glass cleaner is recommended). After the initial cleaning process the glass should be cleaned two or three times during each operating season depending on the environment in the house.



Clean the glass after the first two weeks of operation.

Do not clean glass when hot.

Do not use abrasive cleaners.

Do not strike or slam the glass.

Replacement Of Ceramic Hearth Panels

1. Remove glass.
2. Remove two (2) screws securing grate to hearth pan. (Fig. 43)
3. Set left and right panels on hearth and bring towards front of unit.
4. Replace grate assembly.

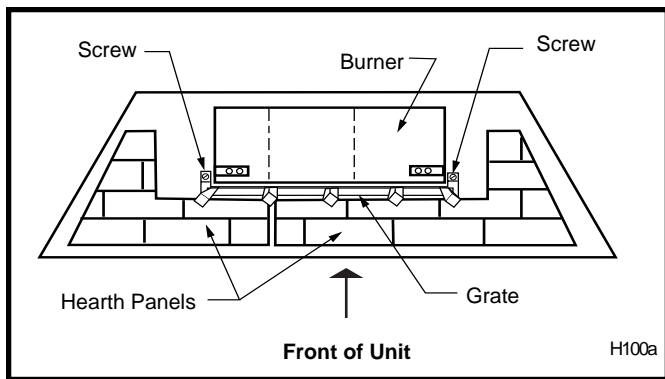

Fig. 43 Hearth panel location.

Installation of Logs

1. Remove front glass. (Refer to "Window Frame Assembly Removal" Section, Fig. 42)
2. Remove logs from packaging.



As with all plastics — these are not toys and should be kept away from children and infants.

3. Place rear log on rear bracket (ensure log is seated properly, levelled and centered to the unit), so it will not move from side to side and is firmly positioned on the bracket. Be sure log is as far forward as possible on bracket.
4. Place front left log on top of burner, left side. Align log's bottom holes with left bracket log locator studs.
5. Place front right log on top of burner, right side. Align log's bottom holes with right bracket log locator studs.
6. Place ember material on top of burner. (See "Ember Material Placement" Section).
7. Place top left cross log onto locator notches. Ensure log is secure.

LOGS	DV360	DV580
Log Front Left	B25	E1
Log Front Right	B26	E2
Log Rear	B27	E3
Log Top Left	B28	E4
Log Top Center Left	--	E5
Log Top Center Right	--	E6
Log Top Right	B29	E7

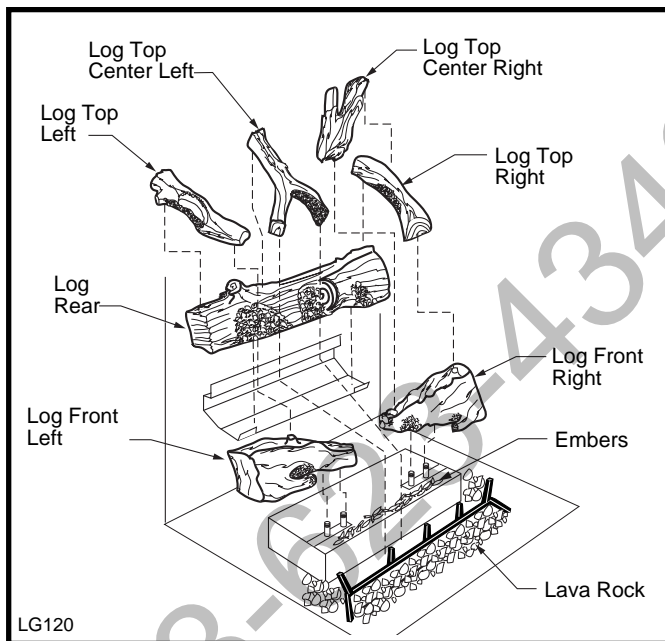

Fig. 44 DV580 log, lava rock and ember placement.

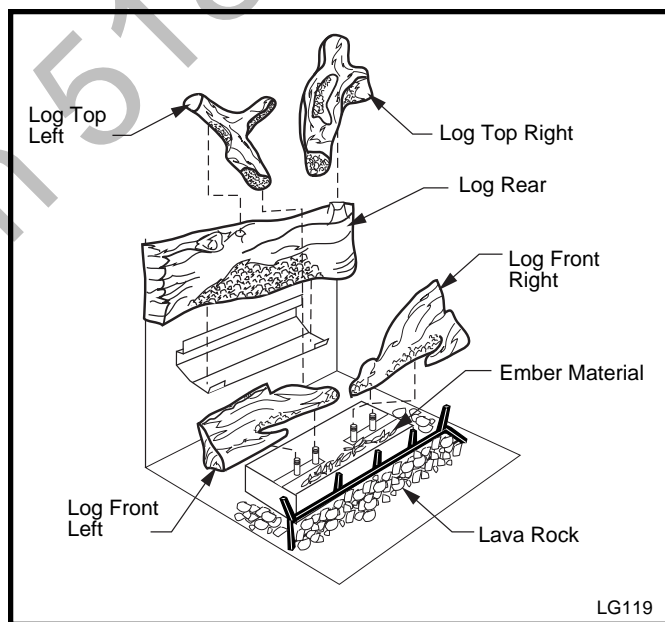

Fig. 45 DV360 log and ember placement.



Top logs must be placed properly onto notches.

Ember Material Placement

Place the hard ceramic ember material on the burner in front of the front logs. Place small dime size ceramic wool on top of hard ceramic embers. Place small pieces in hole of top cross log and on front of the front logs by placing a small piece of wool on your fingertip and pushing it onto the log. Do not place ember material in the inside corners of the front logs.

Lava Rock

The lava rock provided with this fireplace must be placed on the firebox base around the sides of the burner assembly and on the tray beneath the grate.



Under no circumstances should this lava rock be placed on any part of the burner assembly.

Flame & Temperature Adjustment

For fireplaces equipped with Hi/Lo valves, flame adjustment is accomplished by rotating the Hi/Lo adjustment knob located near the centre of the gas control. (Fig. 46 or 47)

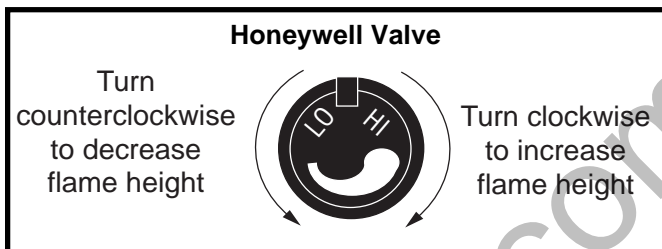

Fig. 46 Flame adjustment knob for Honeywell valve.

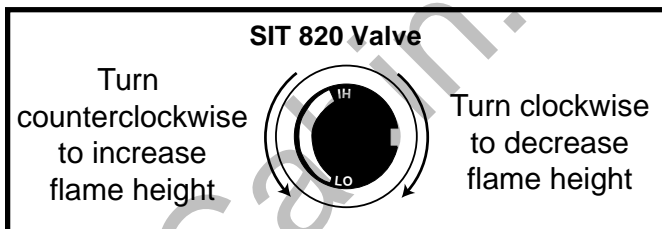

Fig. 47 Flame adjustment knob for SIT valve.

Flame Characteristics

It is important to periodically perform a visual check of the pilot and the burner flames. Compare them to the pictorials illustrated below (Figs. 48, 49, 50). If any of the flames appear abnormal call a service person.

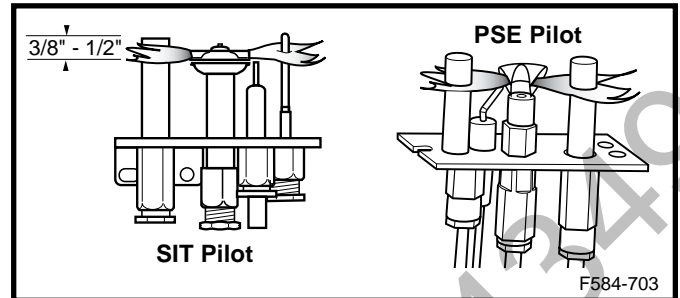

Fig. 50 Correct pilot flame appearance.

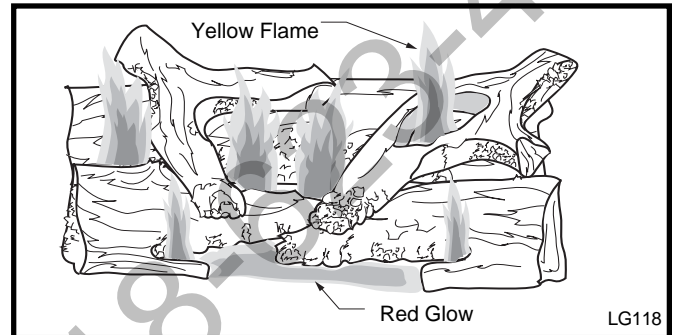

Fig. 49 Correct burner flame appearance for DV360 model.

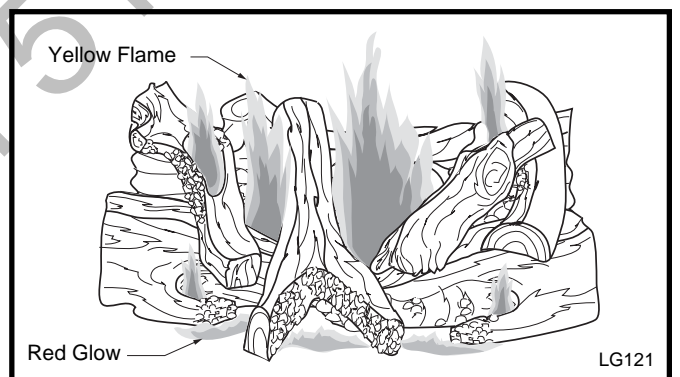

Fig. 50 Correct burner flame appearance for DV580 model.

Inspecting the Venting System

This appliance venting system is designed and constructed to develop a positive flow adequate to remove flue gases to the outside atmosphere.

Any foreign objects in the venting system, except those designed specifically for the venting system, may cause spillage of flue gases.

To inspect the venting system, make sure the main gas valve is off. Remove window frame assembly (Refer to Window Frame Assembly Removal Section). Using a flashlight, check the area above the baffle in the combustion dome. Clean if necessary.

Lighting and Operating Instructions

FOR YOUR SAFETY READ BEFORE LIGHTING

WARNING: If you do not follow these instructions exactly, a fire or explosion may result causing property damage, personal injury or loss of life.

- This heater has a pilot which must be lit manually. When lighting the pilot follow these instructions exactly.
- BEFORE LIGHTING smell all around the heater area for gas. Be sure to smell next to the floor because some gas is heavier than air and will settle on the floor.

WHAT TO DO IF YOU SMELL GAS

- Do not try to light any fireplace
- Do not touch any electric switch
- Do not use any phone in your building
- Immediately call your gas supplier from a

neighbor's phone. Follow the gas supplier's instructions.

- If you cannot reach your gas supplier, call the Fire Department
- Use only your hand to push in or turn the gas control knob. Never use tools. If the knob will not push in or turn by hand, do not try to repair it, call a qualified service technician. Applying force or any attempted repair may result in a fire or explosion.
 - Do not use this fireplace if any part has been under water. Immediately call a qualified service technician to inspect the heater and to replace any part of the control system and any gas control which has been under water.

Lighting Instructions

- STOP!** Read the safety information above.
- Turn off all electrical power to the fireplace.
- For MN/MP/TN/TP appliances ONLY, go on to Step 4. For RN/RP appliances turn the On/Off switch to "OFF" position or set thermostat to lowest level.
- Open control access panel.
- Push in gas control knob slightly and turn clockwise  to "OFF".



Euro SIT

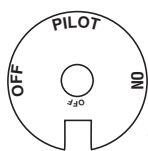

SIT NOVA

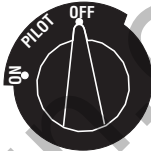

Honeywell

- Wait five (5) minutes to clear out any gas. Then smell for gas, including near the floor. If you smell gas, STOP! Follow "B" in the safety information above. If you do not smell gas, go to the next step.
- Remove glass door before lighting pilot. (See Glass Frame Removal section).
- Visibly locate pilot by the main burner.
- Turn knob on gas control counterclockwise  to "PILOT".

- Push the control knob all the way in and hold. Immediately light the pilot by repeatedly depressing the piezo spark ignitor until a flame appears. Continue to hold the control knob in for about one (1) minute after the pilot is lit. Release knob and it will pop back up. Pilot should remain lit. If it goes out, repeat steps 5 through 8.

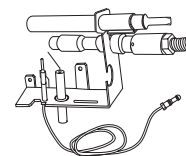
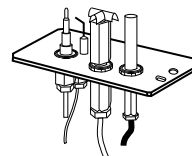
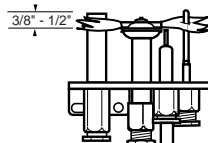

- If knob does not pop up when released, stop and immediately call your service technician or gas supplier.
 - If after several tries, the pilot will not stay lit, turn the gas control knob to "OFF" and call your service technician or gas supplier.
- Replace glass door.
 - Turn gas control knob to "ON" position.
 - For RN/RP appliances turn the On/Off switch to "ON" position or set thermostat to desired setting.
 - Turn on all electrical power to the fireplace.

To Turn Off Gas To Heater

- Turn the On/Off switch to Off position or set the thermostat to lowest setting.
- Turn off all electric power to the fireplace if service is to be performed.
- Open louvre assembly bottom.
- Push in gas control knob slightly and turn clockwise  to "OFF". Do not force.
- Close control access panel.

Instructions for RF Comfort Control Valve

The Comfort Control Valve allows remote control of temperature, fan and flame appearance.

NOTE: The antenna should hang in free air away from grounded metal.

Operation

1. If the manual switch is in remote position, switch it to LOCAL. (Fig. 51)
2. Turn the pilotstat knob counterclockwise from OFF to the PILOT position, push the knob down, and hold in position. The pilot valve opens and allows gas to flow to the pilot burner.
3. Push plunger on the piezo until the pilot burner is lit. When the pilot burner is lit, the LED on the control will come on after approximately 40 seconds and will be continuously red. When the light turns off which will be approximately 10 seconds after it has been continuously red, the receiver/valve is fully powered.

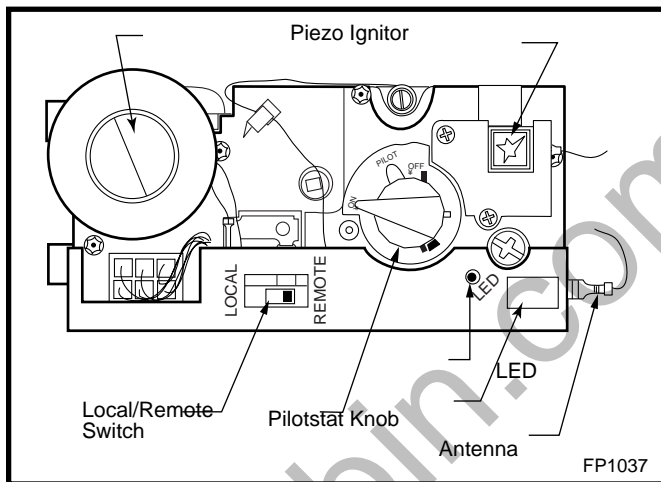

Fig. 51 Comfort control valve.

4. Release the knob. The shaft will move upward. The pilot burner should now stay burning. If the pilot burner goes out, repeat step 2.
5. Turn the knob counterclockwise to the ON position. If the manual switch is in the LOCAL position, the main burner will turn on immediately.
6. ON the initial use of a transmitter, a recognition operation is required between the receiver/valve and transmitter. Change the switch from LOCAL to REMOTE. Press the fan or flame button on the transmitter within 30 seconds. The LED will blink indicating the transmitter will now work with the receiver/valve. If the switch continues in the REMOTE position, the transmitter will now control the main valve, flame modulation level and fan control.

7. If the manual switch is in the LOCAL position, the valve will be at the highest fixed pressure setting. The transmitter will control the fan only.

Shut Off Procedure

If the manual switch is in the REMOTE position, the transmitter can shut off the main burner and fan. However, the control is still on and a command from the transmitter can turn on the main burner or fan.

To shut off the system, turn the pilotstat knob clockwise to the OFF position. This action closes the main gas and safety valves. The transmitter cannot turn on the main burner or fan.

Transmitter Operation

Off Mode

In the OFF mode, the fireplace flame and fan are off, the display will show OFF and displays the room temperature. If the receiver is in REMOTE mode, the fireplace will shut off.

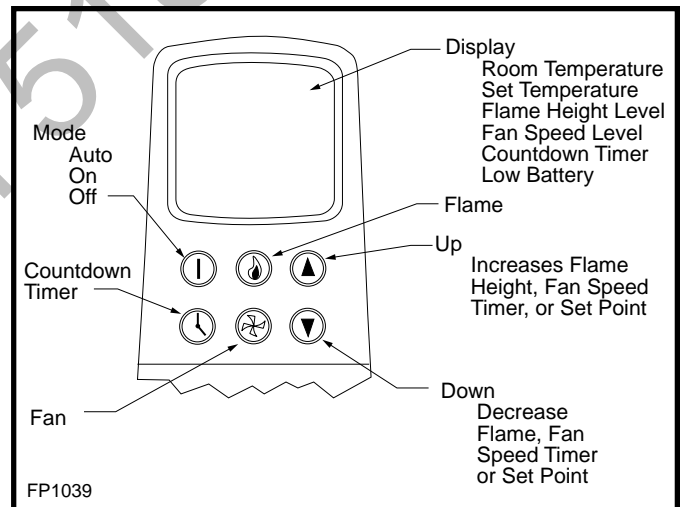

Fig. 52 Transmitter diagram.

On (Manual) Mode

In the ON mode, the room temperature, flame and fan levels will be shown. MANUAL will appear next to both the flame and fan icons.

When the control is in the ON mode, the flame and fan levels, and delay timer are changed with the up and down buttons. To change the flame level, press the flame button followed by an arrow key. To change the fan level, press the fan key followed by an arrow key. Pushing the arrow key once will change the level by one unit.

Delay Timer Mode

The shut off delay timer has a maximum of 2 hours and a minimum of zero minutes. To change the timer level, press the time key followed by an arrow key. Pushing the key once will change the timer by 10 minutes.

Auto Mode

In the AUTO mode, the room temperature, set temperature, flame and fan levels will be shown. AUTO will appear next to both the flame and fan icons.

When the control is in the AUTO mode, the main burner will turn on/off or modulate based on the heat needed to maintain the set temperature. The flame level will change automatically to optimize the heat output needed to maintain the set temperature. To change the set temperature, press the up or down key. Pushing a key once will change the temperature by one degree.

In the AUTO mode, the fan speed will increase with increasing flame height or decrease with decreasing flame height. "AUTO" is displayed next to the flame and fan icons.

Fan Override During Auto Mode

If a lower or higher fan speed is desired when operating in the AUTO mode, the fan speed can be overridden by pushing the fan button followed by the up or down key. Pushing a key once will change the fan level by one unit. In this mode "AUTO" is displayed next to the flame icon and "MANUAL" is displayed next to the fan icon.

Change Between F/C Temperature Units

Push the up and down arrow keys simultaneously for at least 3 seconds to toggle between Fahrenheit and Celsius units.

Disable Thermostat Function

To disable the thermostat function in the AUTO mode, push the time and down keys simultaneously for at least 3 seconds.

To Change Batteries

1. Remove cover on the backside of the transmitter. Install 3 AAA batteries as shown and reattach cover.
2. Once steps 1-3 in OPERATION are completed, receiver/valve and transmitter are now ready. Press any button on transmitter for recognition process to occur between the receiver/valve and transmitter.
3. Use functions as described in TRANSMITTER section.

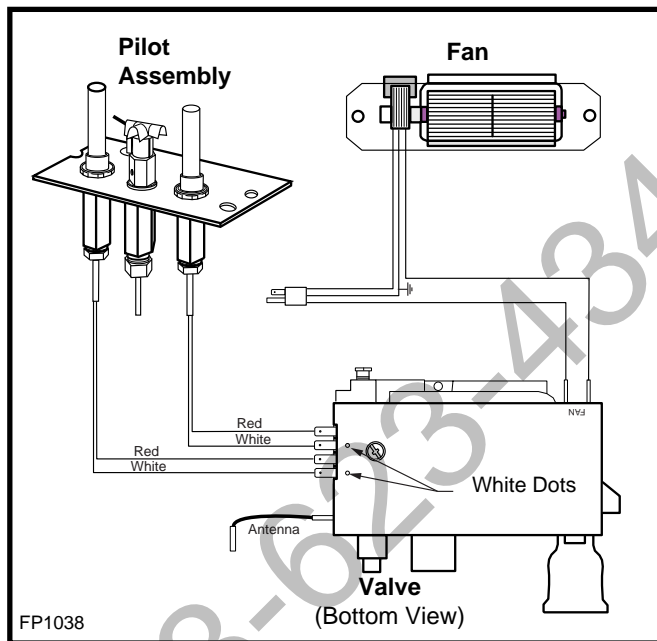

Fig. 53 Comfort Valve wiring diagram.

Troubleshooting

1. Locate LED light on valve.
2. LED will blink after every valid command received by the transmitter; this is not an error.
3. Failure codes may occur anytime after pilot burner is lit.
4. Sequence is failure code followed by light not blinking for 30 seconds.
5. In the event of multiple failure codes, next failure code follows previous failure code by approximately 3 seconds.

If an Error Code 3 is observed while performing the testing, complete the following:

1. Make sure the spade connectors are pushed all the way on. If the Error Code 3 is still showing, then go to the next step.
2. Switch the front two thermopile leads with the back two. Be sure the white lead is connected to the spade with the white dot next to it. If the Error Code 3 is still showing, replace the thermopiles.

If an Error Code 8 is observed while performing the testing, complete the following:

1. Confirm the valve is not in REMOTE mode.
 - If the valve is producing Error Code 8 and in REMOTE mode, the valve is defective and should be replaced.
 - If the valve is in LOCAL mode and producing Error Code 8, then go to the next step.

- Slide the Remote/Local switch to REMOTE and teach the valve a transmitter (refer to Item 6, page 1). The Error Code will clear itself after approximately 1½ minutes and return to normal operation.

LED Count	Service Action
8	Replace valve
7	Confirm stepper motor connection exists
5	Confirm fan connection exists and works
4	Confirm gas type; jumper in place
3	Replace thermopiles
2	Turn fan ON

NOTE: Some keys are not active.

Auto Path

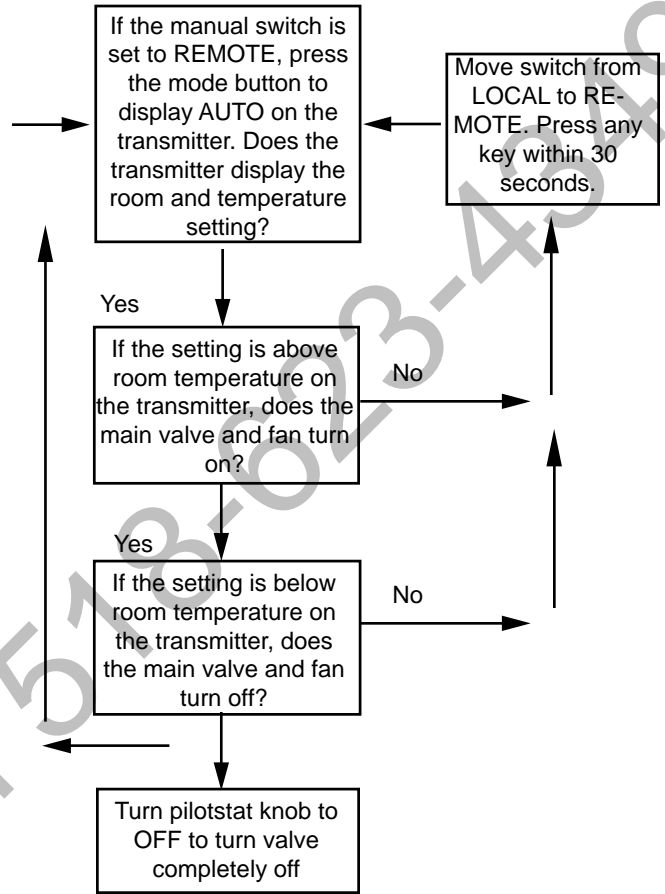

Comfort Valve system control sequence of operation with transmitter

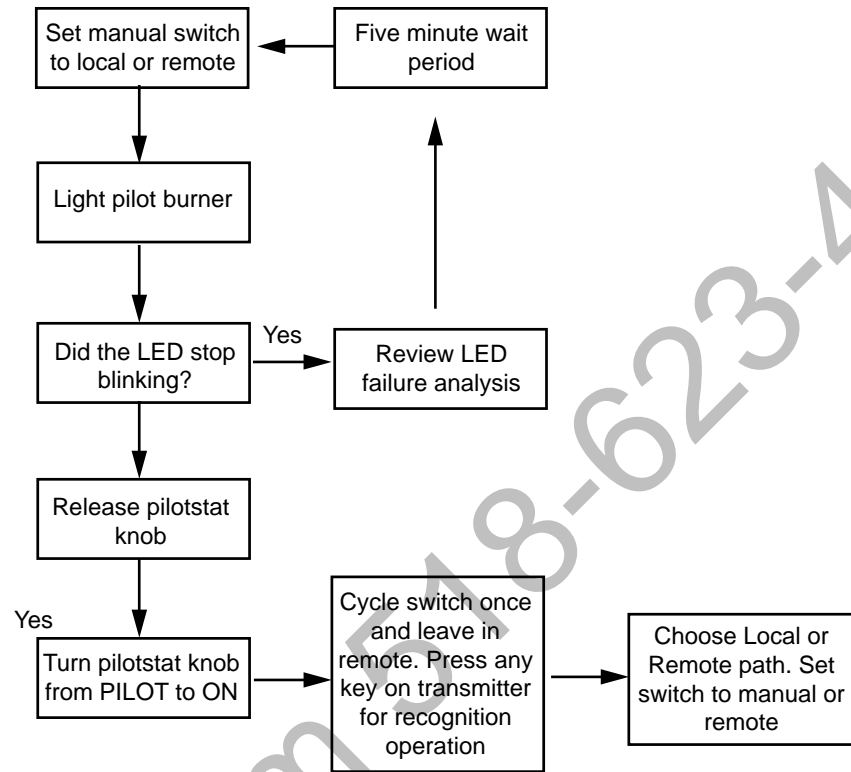

Local Path

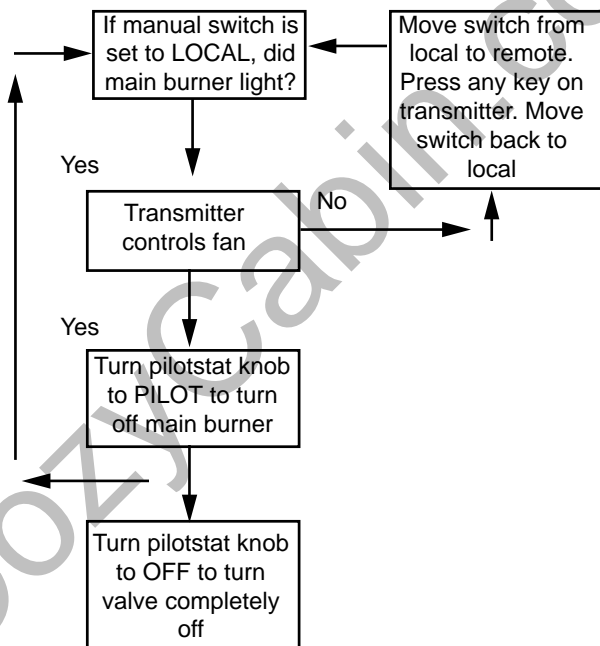

On Path

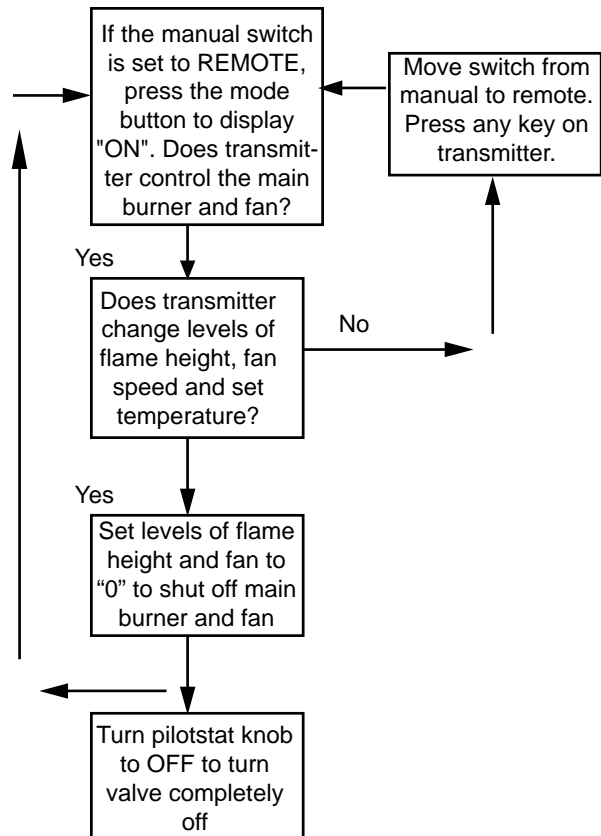

Troubleshooting – Honeywell VS8421



Window Frame Assembly to be Removed Before Service Work

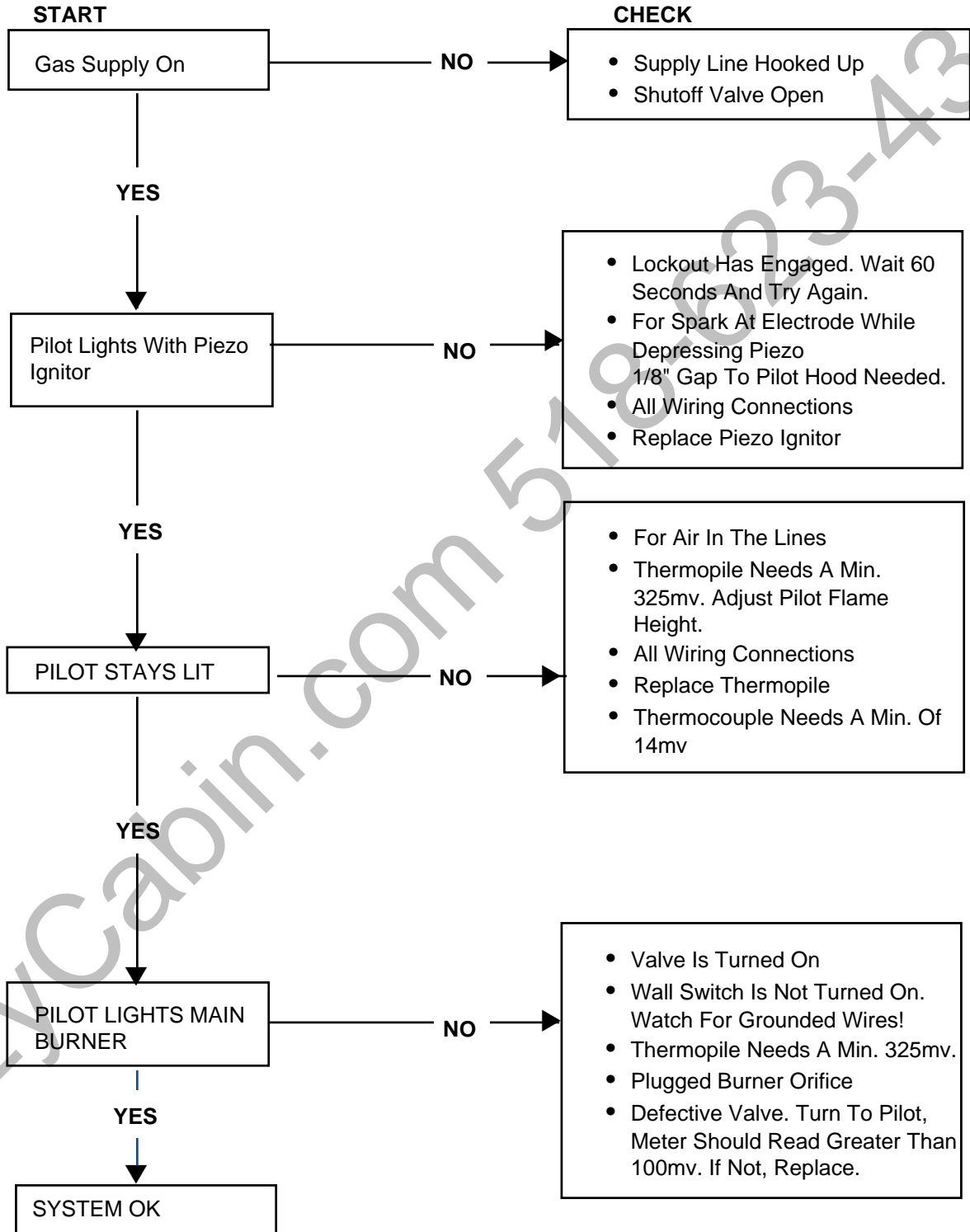

Trouble Shooting the Gas Control System

SIT NOVA 820 Millivolt Valve

Note: Before trouble shooting the gas control system, be sure external gas shut off is in the “On” position.

WARNING: Before doing any gas control service work, remove glass front.

SYMPTOM	POSSIBLE CAUSES	CORRECTIVE ACTION
1. Spark ignitor will not light	A. Defective or misaligned electrode at pilot.	Using a match, light pilot. If pilot lights, turn off pilot and push the red button again. If pilot will not light - check gap at electrode and pilot-should be 1/8" to have a strong spark.
	B. Defective ignitor (Push Button)	Push Piezo Ignitor Button. Check for spark at electrode and pilot. If no spark to pilot, and electrode wire is properly connected, replace ignitor.
2. Pilot will not stay lit after carefully following lighting instructions.	A. Defective pilot generator (thermocouple), remote wall switch.	Check pilot flame. Must impinge on thermocouple/thermopile. Note: this pilot burner assembly utilizes both-a thermocouple and a thermopile. The thermocouple operates the main valve operation (On and Off). Clean and or adjust pilot for maximum flame impingement on thermopile and thermocouple.
	B. Defective automatic valve	Turn valve knob to “Pilot”. Maintain flow to pilot; millivolt meter should read greater than 10 mV. If the reading is okay and the pilot does not stay on, replace the gas valve. Note: An interrupter block (not supplied) must be used to conduct this test.
3. Pilot burning, no gas to main burner	A. Wall switch or wires defective	Check wall switch and wires for proper connections. Jumper wire across terminals at wall switch, if burner comes on, replace defective wall switch. If okay, jumper wires across wall switch wires at valve, if burner comes on, wires are faulty or connections are bad.
	B. Thermopile may not be generating sufficient millivoltage.	<ol style="list-style-type: none"> 1. Be sure wire connections from thermopile at gas valve terminals are tight and thermopile is fully inserted into pilot bracket. 2. One of the wall switch wires may be grounded. Remove wall switch wires from valve terminals if pilot now stays lit, trace wall switch wiring for ground. May be grounded to fireplace or gas supply. 3. Check thermopile with millivolt meter. Take reading at thermopile terminals of gas valve. Should read 250-300 millivolts (minimum 150) while holding valve knob depressed in pilot position and wall switch “Off”. Replace faulty thermopile if reading is below specified minimum.
	C. Plugged burner orifice.	Check burner orifices for debris and remove.
	D. Defective automatic valve operator.	Turn valve knob to “On”, place wall switch to “On” millivolt meter should read greater than 100 mV. If the reading is okay and the burner does not come on, replace the gas valve.
4. Frequent pilot outage problem.	A. Pilot flame may be too low or blowing (high) causing the pilot safety to drop out.	Clean and/or adjust pilot flame for maximum flame impingement on thermopile and thermocouple.
	B. Possible blockage of the vent terminal.	Check the vent terminal for blockage (recycling the flue gases)

Conversions must be completed by qualified personnel

Fuel Conversion Instructions

To convert the DV360/580 units for use with a different gas follow these instructions. Before proceeding, turn control knob on valve to "OFF" and turn gas supply OFF. Turn OFF any electricity that may be going to the appliance.

CAUTION: Logs may be HOT! Allow to cool before proceeding.

1. Open louvre assembly bottom to gain access to valve. Remove window frame assembly. (See "Window Frame Assembly Removal", Page 21, Fig. 42)
2. Remove logs if previously installed.

Honeywell Valve

1. Remove cap from HI/LO knob. This can be accomplished by lifting the plastic cap off the screw. (Fig. 54)
2. Remove the screw from center of HI/LO knob with small screwdriver turning counterclockwise. (Fig. 54)
3. Insert conversion screw supplied in conversion kit. Blue for natural gas, red for LP.
4. Tighten screw, replace cap.

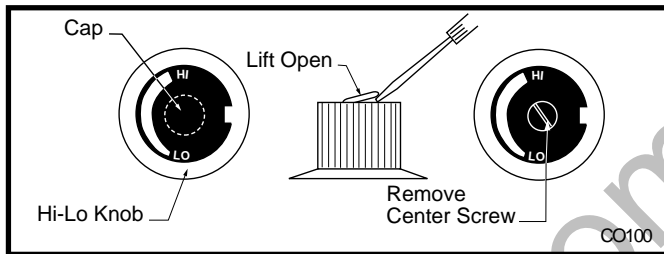

Fig. 54 Remove center screw from Hi-Lo knob.

NOVA SIT820 Valve

1. Using the TORX T20 bit, remove and discard the three (3) pressure regulator mounting screws (A), pressure regulator tower (B) and the spring and diaphragm assembly (C). (Fig. 55)

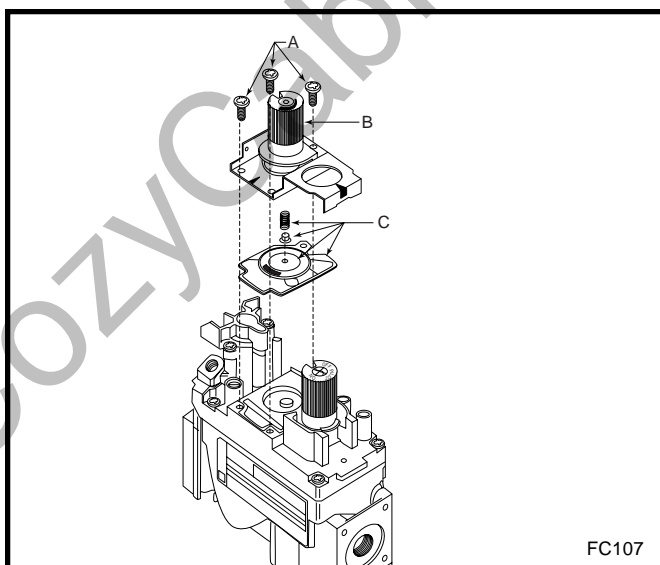

Fig. 55 Remove mounting screws, pressure regulator tower and spring and diaphragm assembly.

2. Insure the rubber gasket (D) is properly positioned and install the new HI/LO pressure regulator assembly to the valve using the new screws (E) supplied with the kit. Tighten the screws securely. (Ref. torque = 25 in/lb) (Fig. 56)
 3. Install the enclosed conversion label (F) to the valve body where it can easily be seen. (Fig.56)
- Valve conversion is complete.

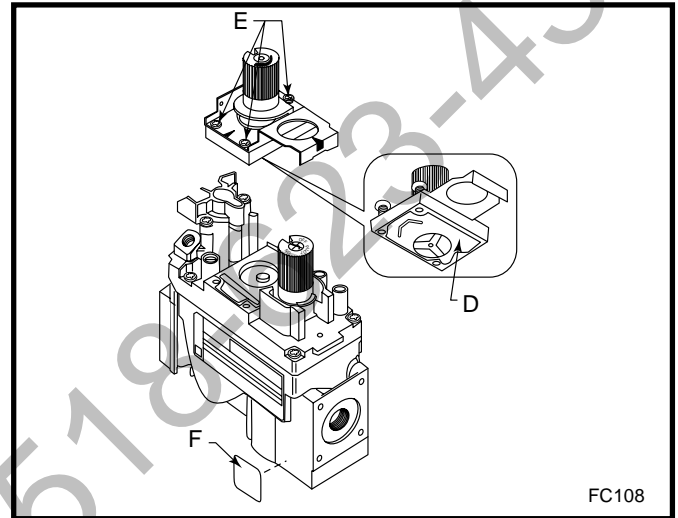

Fig. 56 Replace regulator.

Burner and Pilot Orifice Conversion

1. Remove manifold mounting screw from burner. (Fig. 57)
2. Remove burner orifice from manifold assembly using 3/8" wrench. (Fig. 58)
3. Install conversion orifices in place of orifices just removed.

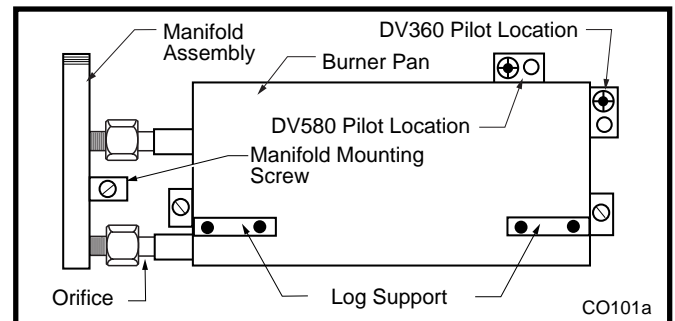

Fig. 57 Remove manifold assembly.

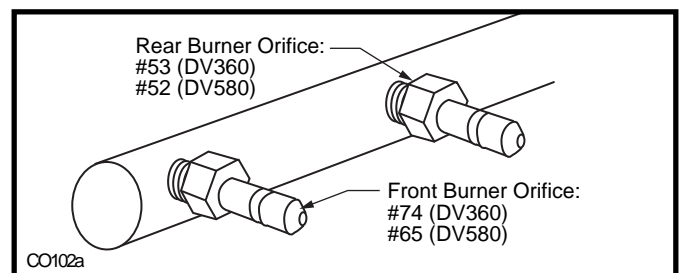

Fig. 58 Remove burner orifice, replace with LP orifice.

4. Remove air shutters from burner pan by removing shutter retaining screw then air shutter. (Fig. 59)
5. Install air shutters supplied in kit on burner pan. Replace shutter retaining screw. For conversion to natural gas adjust both air shutters so slots are covered. For conversion to LP gas, adjust both air shutters so all slots and holes are visible. Secure shutter retaining screw. (Fig. 60)
6. Re-install manifold to burner pan.

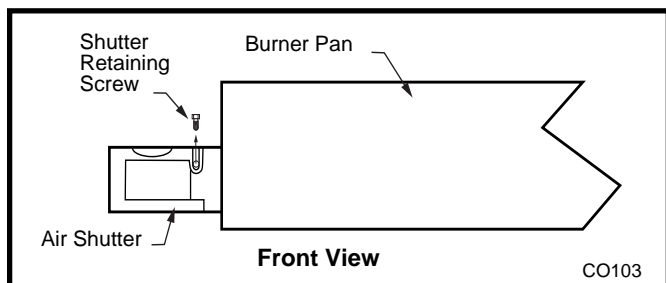

Fig. 59 Remove air shutter from burner pan.

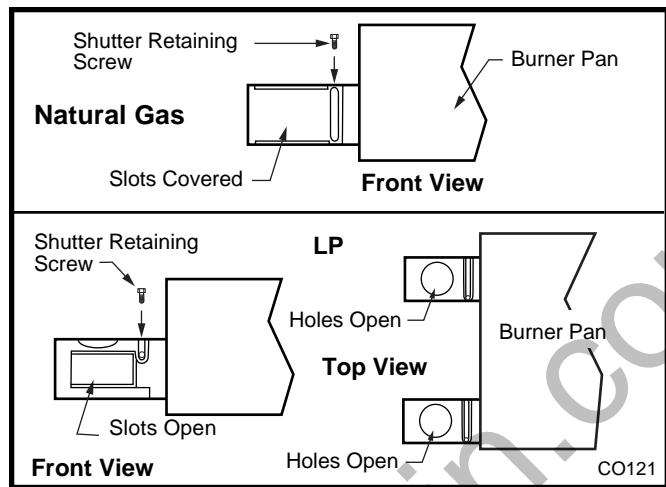

Fig. 60 Install conversion shutter. Adjust holes and slots.

NOTE: It is not necessary to remove the pilot tube for conversion.

7. Remove pilot hood by lifting up. (Fig. 61)
8. Remove pilot orifice with allen wrench. (Fig. 62)
9. Install conversion pilot orifice.
10. Re-install pilot hood and be sure to align with index tab. Installation is complete.

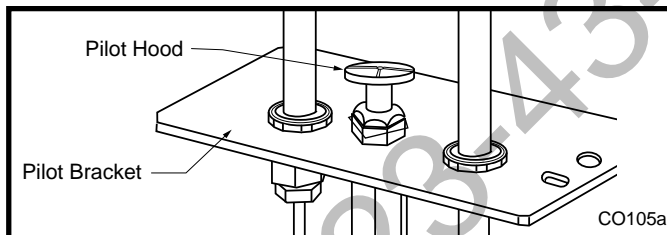

Fig. 61 Remove pilot hood.

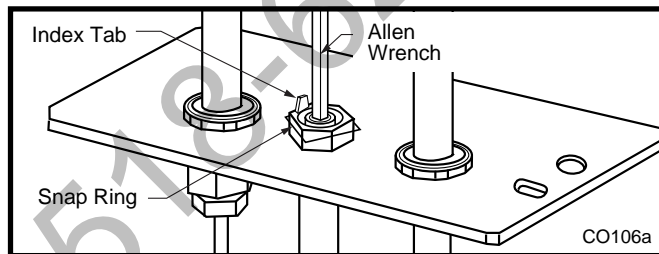

Fig. 62 Remove pilot orifice.

Fuel Conversion Instructions Honeywell Comfort Control Valve ONLY



WARNING: The conversion must only be undertaken by a qualified, certified gas appliance installer.

Refer to Table 1 for the correct conversion kit. The following instructions apply only to these kits.

Table 1

Converting Natural Gas to LP		
Model	Serial # starting at*	Kit #
DV360RFN	H11K0001282215	20004848
DV580RFN	I11K0001331308	20004850
Converting LP to Natural Gas		
DV360RFP	H11L0001282441	20004849
DV580RFP	I11L0001296064	20004851

*For units with serial #'s prior to those listed, use conversion kits 20003636 (DV360) and 20003638 (DV580) to convert from Natural to LP and 20003635 (DV360) and 20003637 (DV580) to convert from LP to Natural. Refer to instructions provided with these kits for conversion procedure.

Installation Precautions

Before proceeding, turn control knob on valve to **OFF** and turn gas supply **OFF**. Turn **OFF** any electricity that may be going to the appliance. **CAUTION: Logs may be hot!**

Conversion Procedure

1. Open bottom grille to gain access to valve. Remove glass door. (Refer to "Window Frame Assembly Removal Section" Page 23, Fig. 42)
2. Remove logs if previously installed. **CAUTION: Logs may be hot!**
3. Remove and replace plug on lower right hand side of the valve; Red for LP and blue for NG. (Fig. 63)

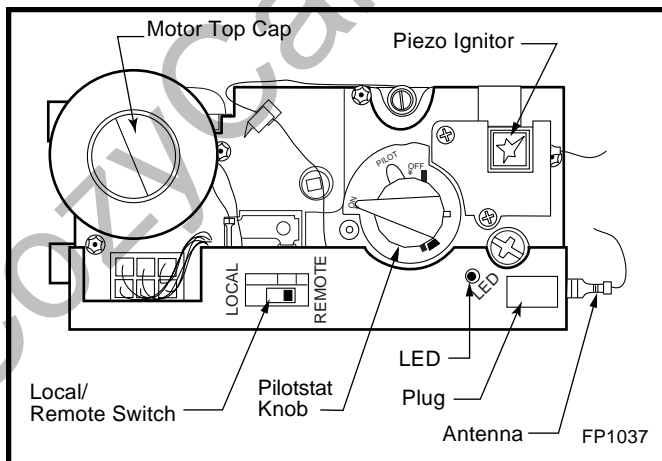

Fig. 63 Comfort control valve.

4. Remove motor top cap. Depress and turn center plunger until arrow points to correct screw. Red for LP and Blue for NG. **NOTE:** Plunger will "snap" into NG position when arrow is close to blue screw. It will not "snap" at LP (Red) position. (Fig. 64)

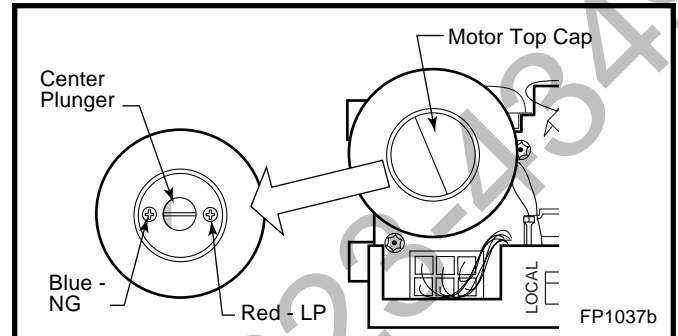

Fig. 64 Depress and turn center plunger.

5. Remove manifold mounting screw. (Fig. 65)
6. Remove burner orifice from manifold assembly using 7/16" wrench. (Fig. 66)
7. Install conversion orifice in place of orifice just removed. Refer to Table 2.

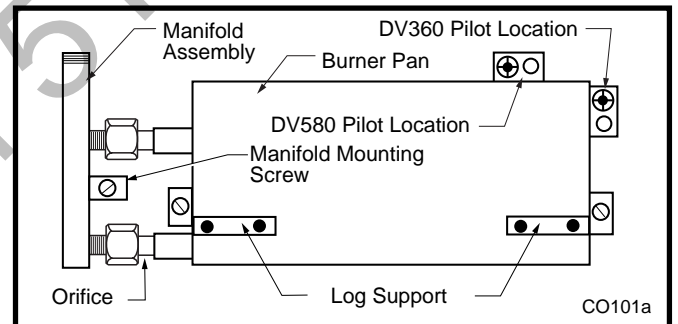

Fig. 65 Remove manifold assembly.

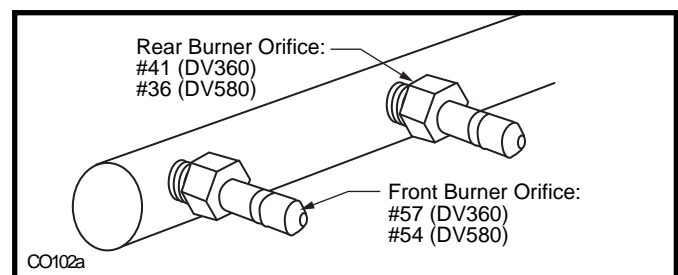

Fig. 66 Remove burner orifice, replace with LP orifice.

8. Remove both air shutters from burner pan by removing air shutter retaining screw then air shutter. (Fig. 67)
9. Install conversion air shutters on burner pan. Replace air shutter retaining screw. Adjust both air shutters. Refer to Table 3 for proper air shutter adjustment. Secure air shutter retaining screw. (Fig. 68)
10. Reinstall manifold mounting screw.

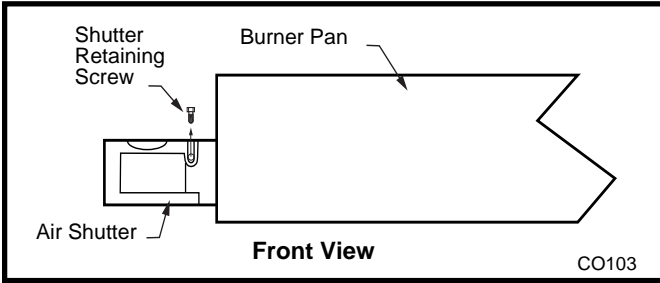

Fig. 67 Remove air shutter from burner pan.

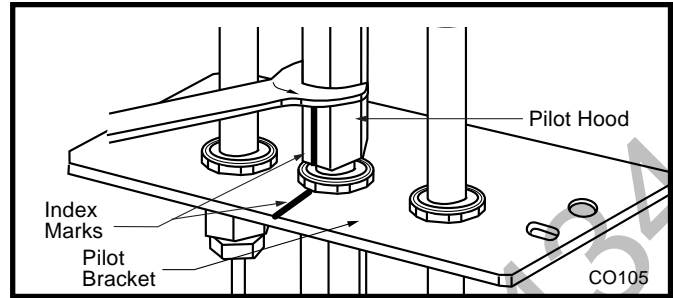

Fig. 69 Remove pilot hood.

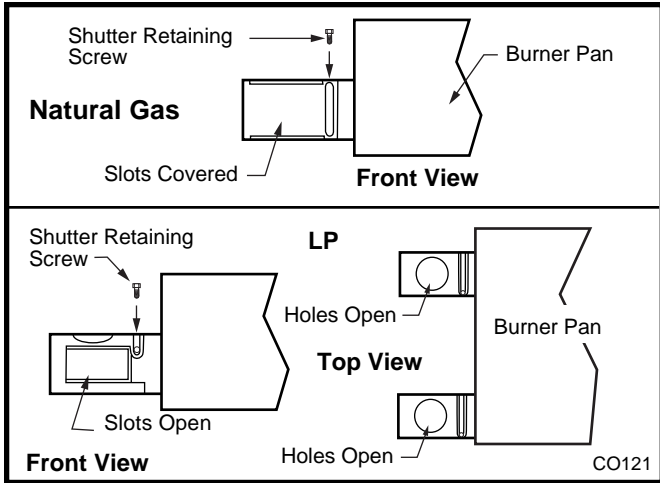

Fig. 68 Install conversion shutter. Adjust holes and slots.

NOTE: It is not necessary to remove the pilot tube for conversion.

11. Loosen pilot hood turning counterclockwise using a 7/16" wrench. (Fig. 69)
12. Remove pilot orifice with needlenose pliers. (Fig. 70)
13. Install conversion pilot orifice.
14. Reinstall pilot hood. Be sure to align pilot hood with index marks.

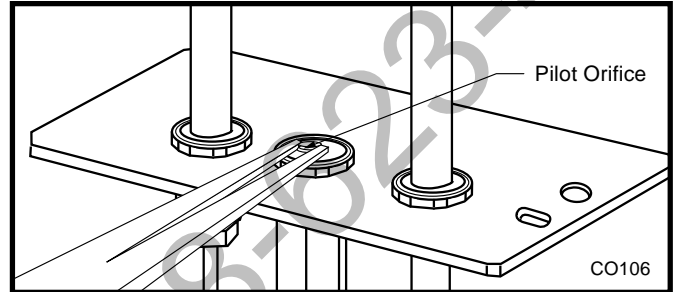

Fig. 70 Remove pilot orifice.

15. Turn the gas supply valve and gas valve on and test for leaks. Use a 50/50 solution of liquid soap and water to test for leaks at gas fittings and joints. Apply water/soap solution with brush only - **do not over apply. NEVER test with an open flame.**
 16. Follow procedure on rating plate to light the pilot. Check for leaks.
 17. Turn main burner on and check for leaks.
 18. Install logs. Refer to Page 24 for proper log placement.
- Installation complete.

Table 2 Orifice Size Matrix

Conversion to Natural Gas							Input (BTU/H)	
Model	Part #	Kit #	Front	Part #	Rear	Part #	Minimum	Maximum
DV360RFP	H11L00	20004849	#57 / .043"	20002409	#38 / .101"	20002408	21,000	30,000
DV580RFP	I11L00	20004851	#54 / .055"	20002150	#36 / .106"	20002498	26,500	35,000
Conversion to LP							Input (BTU/H)	
Model	Part #	Kit #	Front	Part #	Rear	Part #	Minimum	Maximum
DV360RFN	H11K00	20004848	#74 / .022"	20002390	#53 / .059"	20002385	21,000	30,000
DV580RFN	I11K00	20004850	#65 / .035"	20002540	#52 / 1.55"	20002958	27,000	38,000

Table 3 Air Shutter Adjustment

Model	Natural Gas	LP
DV360	Slots Covered	Fully Open
DV580	Slots Covered	Fully Open

Maintenance

Burner and Burner Compartment

It is important to keep the burner and the burner compartment clean. At least once per year the logs and lava rock/ember material should be removed and the burner compartment vacuumed and wiped out. Remove and replace the logs as per the instructions in this manual.



Always handle the logs with care as they are fragile and may also be hot if the fireplace has been in use.

FK24/FK12 Fan Assembly

The fan unit requires periodic cleaning. At least once per month in the operating season, open the lower louver panels and wipe or vacuum the area around the fan to remove any build up of dust or lint.

Brass Trim

Clean the brass trim pieces using a soft cloth lightly dampened with lemon oil. Do not use water or household cleaners on any brass components.

Contact your local representative to arrange an annual service program.

Cleaning the Standing Pilot Control System

The burner and control system consists of

- burner tube
- gas orifice
- pilot assembly
- thermopile
- millivolt gas valve

Most of these components may require only an occasional checkup and cleaning and some may require adjustment. **If repair is necessary, it should be performed by a qualified technician.**



Logs May Be HOT!!

1. Turn off pilot light at gas valve side.
2. Let fireplace cool if it has been running.
3. Remove window frame assembly. (Refer to Window Frame Assembly Removal section)
4. Remove logs.
5. Vacuum burner compartment especially around orifice primary air openings.
6. Visually inspect pilot. Brush or blow away any dust or lint accumulation.
7. Reinstall logs.
8. Ignite pilot - Refer to Lighting Instructions.
9. Reinstall window frame assembly.

To obtain proper operation, it is imperative that the pilot and burner's flame characteristics are steady, not lifting or floating.

Typically, the top 3/8" or 1/2" of the thermopile should be engulfed in the pilot flame. (Fig. 71)

To adjust pilot burner; (by qualified service technician)

1. Remove pilot adjustment cap.
2. Adjust pilot screw to provide properly sized flame.
3. Replace pilot adjustment cap.

The primary air shutter is set at factory and should only be adjusted, if necessary, by a qualified service technician.

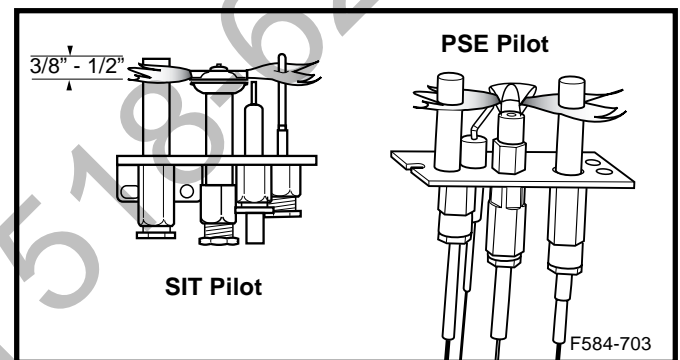
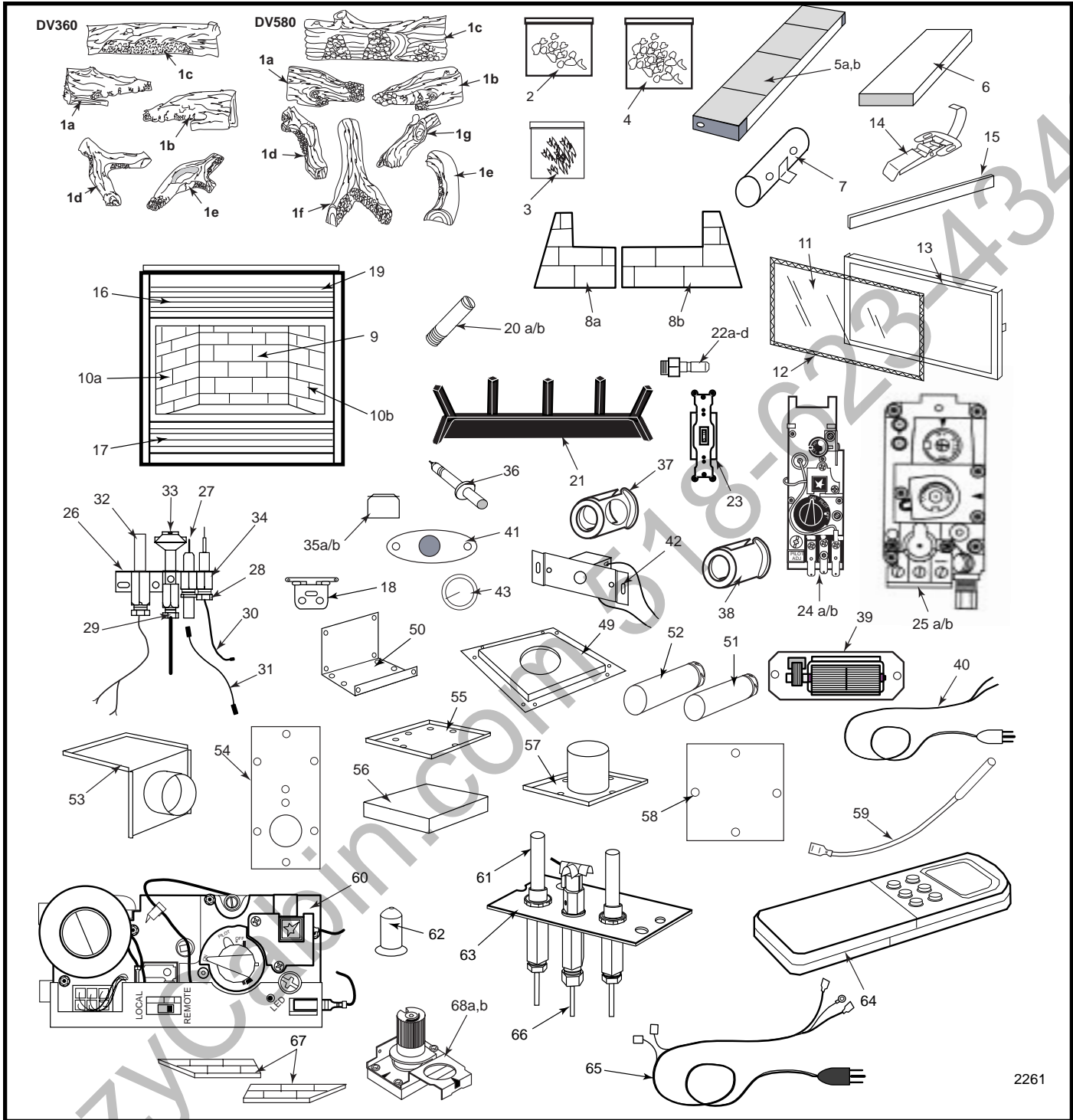

Fig. 71 Correct pilot flame appearance.



Vermont Castings, Majestic Products reserves the right to make changes in design, materials, specifications, prices and discontinue colors and products at any time, without notice.

DV360/580

Ref.	Description	DV360	DV580
1.	Log Set	20002397	20002071
1a.	Log Front Left	B25	E1
1b.	Log Front right	B26	E2
1c.	Log Rear	B27	E3

DV360/580 (continued)

Ref.	Description	DV360	DV580
1d.	Log Top Left	B28	E4
1e.	Log Top Right	B29	E7
1f.	Log Top Center Left	--	E5
1g.	Log Top Center Right	--	E6
2.	Volcanic Rock	20000376	20000376
3.	Ember (Package)	51915	51915
4.	Lava Rock (Burner)	57897	57897
5a.	Burner Housing Assy - Nat.	20002411	20001906
5b.	Burner Housing Assy - LP	20001946	20002401
6.	Ceramic tile (single)	57803	10002165
7.	Manifold Assembly	10000765	10000765
8a.	Ceramic Hearth Panel (Left)	20002274	20002322
8b.	Ceramic Hearth Panel (Right)	20002275	20002323
9.	Ceramic Panel (Rear)	20002273	20002319
10a.	Ceramic Panel (Left Side)	20002271	20002321
10b.	Ceramic Panel(Right Side)	20002272	20002320
11.	Glass with Gasket	20002205	20002369
12.	Gasket Glass	10000992	10000992
13.	Door Frame Assy	20003710	20003711
14.	Clamp Frame Window	54174	54174
15.	Trim Frame Window (Pb) (w/two magnets)	57483	20002072
16.	Louvre Assembly Top	10000039	20002380
17.	Louvre Assembly Bottom	10000040	20002381
18.	Bottom Louvre Hinge	52356	52356
19.	Deflector Top	54364	54364
20a.	LP Valve Conversion - Red	20000550	20000550
20b.	Natural Valve Conversion - Blue	20000572	20000572
21.	Grate Assembly	20002196	20002442
22a.	Orifice - Front Burner - LP	20002390	20002540
22b.	Orifice - Front Burner - Nat.	20002409	20002150
22c.	Orifice - Rear Burner-LP	20002385	20002458
22d.	Orifice - Rear Burner-Nat	20004801	20002498
23.	Switch On/Off	51842	51842
24a.	Valve - Honeywell VS8421 - Nat.	10001782	10001782
24b.	Valve - Honeywell VS8421 - LP	10001759	10001759
25a.	Valve - SiT 820 - Nat.	52677	52677
25b.	Valve - SIT 820 - LP	52678	52678
26a.	Pilot Assembly - Nat.	10002264	10002264
26b.	Pilot Assembly - LP	10002265	10002265
27.	Electrode Ignitor w/Cable	10001297	10001297
28.	Nut Electrode	57886	57886
29.	Pilot tube 1/8" x 24" long w/fittings (SIT Pilot)	10001296	10001296
30.	Thermocouple - RN/RP	53373	53373
31.	Cable Ignitor - RN/RP	53194	53194
32.	Thermopile - RN/RP	51827	51827

DV360/580 (continued)

Ref.	Description	DV360	DV580
33.	Pilot Top Convertible	10002266	10002266
34.	Hood Pilot 3 way	10002385	10002385
35a.	Pilot Orifice #65 (Nat.)	10002268	10002268
35b.	Pilot Orifice #35 (LP)	10002269	10002269
36.	Ignitor Piezo	20000062	20000062
37.	Air Shutter (LP)	20000680	20000680
38.	Air Shutter (Nat.)	20000129	20000129
39.	Fan w/ Bracket (FK24)	54103	54103
40.	Electrical Cord (6ft.)	51865	51865
41.	Fan Temp. Sensor	51704	51704
42.	Speed Control	51738	51738
43.	Speed Control Knob	51882	51882
44.	Remote Switch Kit (Not Shown)	53875	53875
45.	Piezo Ignitor Replacement Kit (Not Shown)	20000062	20000062
46.	Ceramic Refractory Lining Kit (Optional) (Not Shown)	DV360CR	DV580CR
47.	Conversion Kit (Nat. to LP)	20002125	20002130
48.	Conversion Kit (LP to Nat.)	20002123	20002516
49.	Firestop	52523	52523
50.	Zero Clearance Sleeve	54623	54623
51.	7" Starter Pipe	56054	56054
52.	4" Starter Pipe	56053	56053
53.	Plate Cover Air Inlet Ass'y	20002461	20002461
54.	Gasket Plate Air Inlet	10002449	10002449
55.	Flue Cover Plate	10002298	10002298
56.	Flue Cover Gasket	20002391	20002391
57.	Flue Pipe Ass'y	20002481	20002481
58.	Gasket Plate Cover Flue Pipe	10002237	10002237
59.	Antennae HW 395783-1 RFN/RFP Valve	20003561	20003561
60a.	RF Valve 8310E - Natural	20003719	20003719
60b.	RF Valve 8310E - LP	20003720	20003720
61.	Thermopile - RF Valves	20002400	20002400
62a.	Pilot Orifice - Natural - RF	20000908	20000908
62b.	Pilot Orifice - LP - RF	20000907	20000907
63a.	Pilot Assembly - Natural (3 Way) RF	20002266	20002266
63b.	Pilot Assembly - LP (3 Way) RF	20002268	20002268
64.	Transmitter	20002047	20002047
65.	Cord Set	20002541	20002541
66.	Pilot Tube 1/8" x 24" long w/Fittings (PSE Pilot)	10003279	10003279
67.	Refractory Bay39 Set	10000506	n/a
68a.	Regulator Head (Nat.)	10001006	10001006
68b.	Regulator Head (LP)	10001007	10001007

Fuel Conversion Kits

Natural Gas to LP

DV360RN	Kit #20002125	
DV360RFN (Serial #'s starting at H11K0001282215)		Kit #20004848
DV360RFN (Serial #'s up to H11K0001233783)		Kit #20003636
DV580RN	Kit # 20002130	
DV580RFN (Serial #'s starting at I11K0001272002)		Kit #20004850
DV580RFN (Serial #'s up to I11K0001272041)		Kit #20003638

LP to Natural Gas

DV360RP	Kit #20002123	
DV360RFP (Serial #'s starting at H11L0001322779)		Kit #20004849
DV360RFP (Serial #'s up to H11L0001263328)		Kit #20003635
DV580RP	Kit #20002516	
DV580RFP (Serial #'s starting at I11L0001332740)		Kit #20004851
DV580RFP (Serial #'s up to I11L0001272001)		Kit #20003637

CozyCabin.com 518-623-4349

Optional Accessories Available

Fan Kits

FK12 Fan Assembly

1. Open louvre assembly bottom.
2. Install FK12 fan in back of unit between hearth supports. (Fig. 72)
3. Secure fan on velcro strips.
4. Power to the fan can be supplied by plugging the supply lead into a conveniently located wall socket or by using a hard-wired EB-1 connector box.
5. Be sure fan motor does not touch hearth supports.

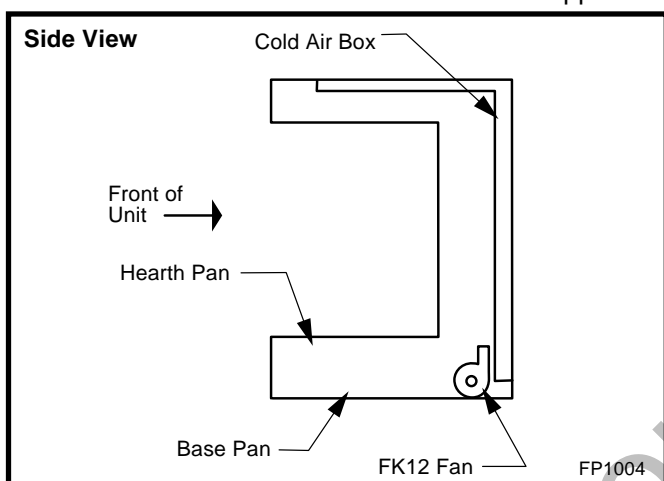

Fig. 72 FK12 Fan Kit placement.

FK24 Fan Assembly

Fan specifications: 120 volt, 60 Hz, .75 Amp.

This fan does not need regular maintenance, however periodic cleaning is required. Check the area under the control door and in front of the fan and wipe or vacuum at least once a month during the operating season. Should this fan require servicing, the power supply must be disconnected.

The FK24 comes with the electrical cord attached.

1. Slide fan assembly from the left side into the fireplace opening, line up mounting holes with screw studs on back of fireplace and fasten with #10 - 24 hex nuts. (Fig. 73)
2. Install thermal sensor on bottom of firebox using #10 - 24 hex nuts.
3. **(Option A)** - Place electronic fan speed control box on bottom of fireplace base, lining up mounting holes with screw studs. Fasten fan speed control box with #10 - 24 hex nuts.
(Option B) - The speed control can be installed in an electrical box at normal wall switch height for convenient access.
4. The power supply may be connected in 2 ways:

Method A

Route the 6' (1.8m) lead fitted to the unit to a conveniently located wall socket.

Method B

If the EB-1 receptacle box (Pt. #ZA1200) was correctly connected when the unit was installed, the fan lead can be directly plugged into the EB-1 plug socket.

5. Whether wiring directly to the fan junction box (Option A) or into the EB1 (electrical box, Option B) first ensure cable is secured using box connector.



The fireplace, when installed must be electrically connected and grounded in accordance with local codes, with the current CSA C22.1 Canadian Electrical Code or for US installations, follow local codes and the National Electrical Code, ANSI/NFPA No. 70.

Hard (Direct) Wire Hook Up

First connect ground wire to ground stud located on the base of either box. Black wire from supply should connect to the variable speed switch. Alternate speed switch wire connects to temperature sensor. Alternate lead from sensor connects to fan. Alternate fan lead connects back to the white supply wire. (Fig. 74)



Any electrical rewiring of this fan must be completed by a qualified electrician.

Turn off all power before hook up.

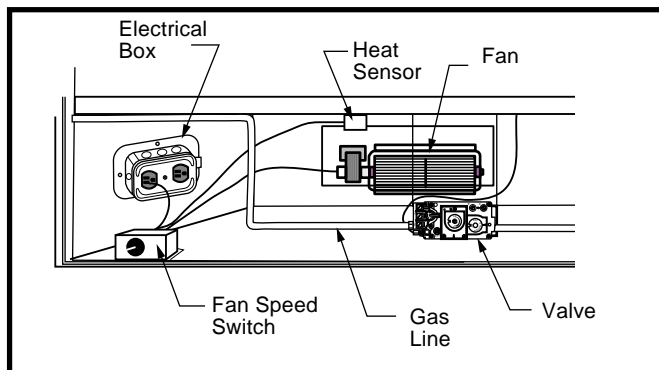

Fig. 73 FK24 fan placement.

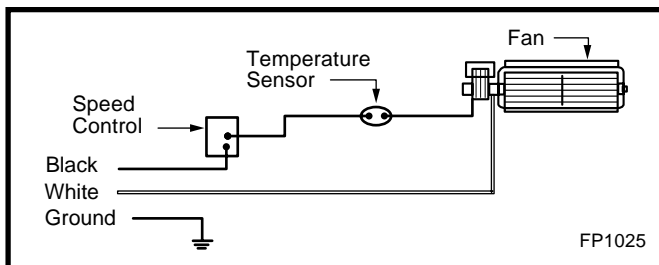

Fig. 74 FK24 fan wiring.

Remote Controls

Optional remote control units are available to control different functions of the appliance.

Model Functions Controlled

MRC1	ON/OFF
MRC2	ON/OFF and Temperature
MRC3	ON/OFF and Temperature control with a digital display and a programmable 24 hour clock
IMT	Wall mounted thermostat control

Ceramic Refractory Panels

Ceramic refractory panels are available to line the firebox area.

Unit	Kit Model
DV360	DV360CR
DV580	DV580CR



Take care when handling the refractory panels as they are fragile until held in place and supported.

Installation Instructions

1. Remove window frame assembly and logs.
2. Insert supports under ceramic hearth panels. (Fig. 75)
3. Remove three (3) screws securing heat shield to combustion dome. (Fig. 76)
4. Place rear ceramic panel in back of unit. (Fig. 77)
5. Place side panels.
6. Replace heat shield, logs and window frame assembly.

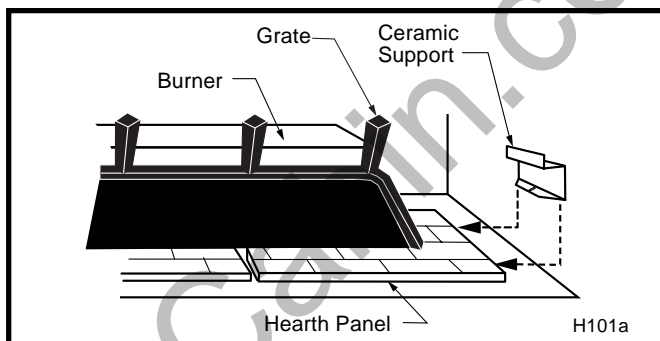

Fig. 75 Ceramic support.

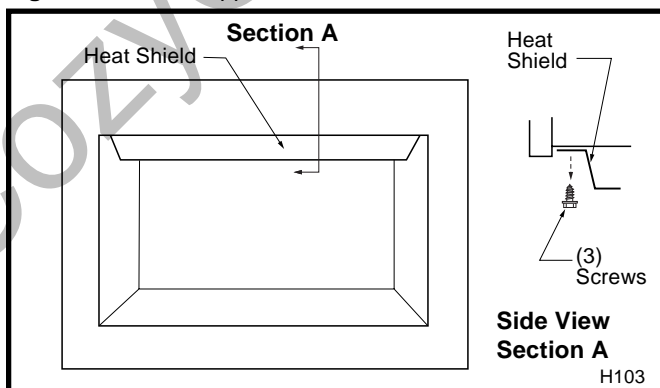

Fig. 76 Heat shield.

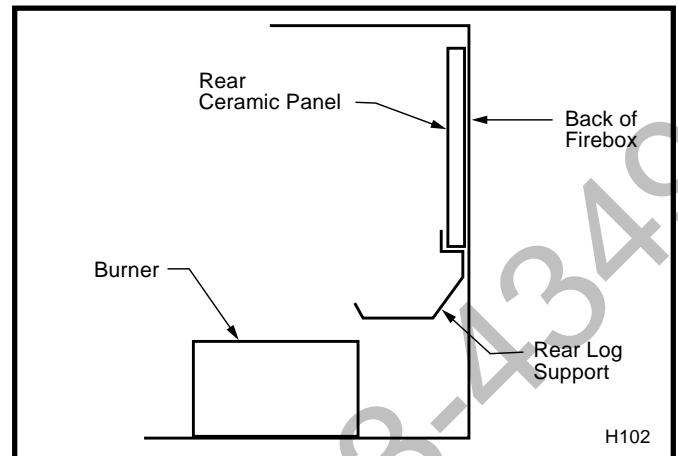

Fig. 77 Rear ceramic panel placement.

Decorative Bay Windows

The bay window kit is available for the DV360 only.

Installation

Remove the existing louvre assembly top.

Assemble the Bay Window Kit according to the instructions supplied with the kit. (Fig. 78)

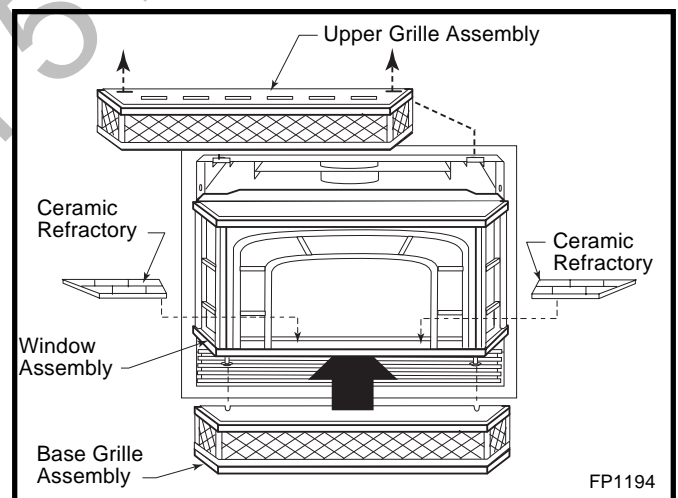

Fig. 78 Bay window.

Decorative Frame Trims

A selection of decorative frame trim kits are available for mounting around the outside of the appliance to enhance its visual effect on the room. Installation instructions for each decorative frame trim are included with the frame trim kit. Contact your authorized distributor for details of the trim kits and ordering information for the trim kits applicable to this model appliance.

CozyCabin.com 518-623-4349

LIMITED LIFETIME WARRANTY

PRODUCT COVERED BY THIS WARRANTY

All Vermont Castings gas stoves, gas inserts, and gas fireplaces, and all Majestic or Northern Flame brand gas fireplaces equipped with an Insta-Flame Ceramic Burner, or standard steel tube burner.

BASIC WARRANTY

The Vermont Castings, Majestic Products Company (hereinafter referred to collectively as the Company) warrants that your new Vermont Castings or Majestic Gas Fireplace/Stove is free from manufacturing and material defects for a period of one year from the date of purchase, subject to the following conditions and limitations.

EXTENDED LIFETIME WARRANTY

The heat exchanger, where applicable, and combustion chamber of every Vermont Castings or Majestic gas product is warranted for life against through wall perforation. All appliances equipped with an Insta-Flame Ceramic Burner have limited lifetime coverage on the ceramic burner plaque. Warrantees are made to the original owner subject to proof of purchase and the conditions and limitations listed on this Warranty Document

COMPONENT WARRANTY

CAST IRON: All external and internal cast iron parts are warranted for a period of three years.

Note: On porcelain enamel finished external parts and accessories The Company offers no Warranty on chipping of enamel surfaces. Inspect all product prior to accepting it for any damage to the enamel.

The salt air environment of coastal areas or a high humidity environment can be corrosive to the porcelain enamel finish. These conditions can cause rusting of the cast iron beneath the porcelain enamel finish, which will cause the finish to flake off.

Dye lot variations with replacement parts and/or accessories can occur and are not covered by warranty.

GLASS DOORS: Glass doors are covered for a period of one year. Glass doors are not warranted for breakage due to misuse or accident. Glass doors are not covered for discoloration or burned in stains due to environmental issues, or improper cleaning and maintenance.

BRASS PLATED PARTS AND ACCESSORIES: Brass parts should be cleaned with Lemon oil only. Brass cleaners cannot be used. Mortar mix and masonry cleaners may corrode the brass finish. The Company will not be responsible for, nor will it warrant any brass parts which are damaged by external chemicals or down draft conditions.

GAS VALVES: Gas valves are covered for a period of one year

ELECTRONIC AND MECHANICAL COMPONENTS: Electronic and mechanical components of the burner assembly are covered for one year. All steel tube burners are warranted for one year.

ACCESSORIES: Unless otherwise noted all components and Vermont Castings, Majestic Products company supplied accessories are covered for a period of one year.

CONDITIONS AND LIMITATIONS

- This new Vermont Castings or Majestic product must be installed by a competent, authorized, service contractor. A licensed technician, as prescribed by the local jurisdiction must perform any installation/service work. It must be installed and operated at all times in accordance with the Installation and Operating instructions furnished with the product. Any alteration, willful abuse, accident, or misuse of the product shall nullify this warranty.
- This warranty is non-transferable, and is made to the original owner, provided that the purchase was made through an authorized supplier of the Company.
- The customer must pay for any Authorized Dealer in-home travel fees or service charges for in-home repair work. It is the dealers option whether the repair work will be done in the customer's home or in the dealer's shop.
- If upon inspection, the damage is found to be the fault of the manufacturer, repairs will be authorized at no charge to the customer parts and/or labor.

- Any part and/or component replaced under the provisions of this warranty is covered for six months or the remainder of the original warranty, whichever is longest.
- This warranty is limited to the repair or replacement of part(s) found to be defective in material or workmanship, provided that such part(s) have been subjected to normal conditions of use and service, after said defect is confirmed by the Company's inspection.
- The company may, at its discretion, fully discharge all obligations with respect to this warranty by refunding the wholesale price of the defective part(s)
- Any installation, labor, construction, transportation, or other related costs/expenses arising from defective part(s), repair, replacement, or otherwise of same, will not be covered by this warranty, nor shall the Company assume responsibility for same. Further, the Company will not be responsible for any incidental, indirect, or consequential damages except as provided by law.
- *SOME STATES DO NOT ALLOW FOR THE EXCLUSION OR LIMITATIONS OF INCIDENTAL AND CONSEQUENTIAL DAMAGES OR LIMITATIONS ON HOW LONG AN IMPLIED WARRANTY LASTS, SO THE ABOVE LIMITATIONS MAY NOT APPLY TO YOUR CIRCUMSTANCES. THIS WARRANTY GIVES YOU SPECIFIC RIGHTS AND YOU MAY HAVE OTHER RIGHTS WHICH VARY FROM STATE TO STATE.*
- All other warranties-expressed or implied- with respect to the product, its components and accessories, or any obligations/liabilities on the part of the Company are hereby expressly excluded.
- The Company neither assumes, nor authorizes any third party to assume on its behalf, any other liabilities with respect to the sale of this Vermont Castings, Majestic product
- The warranties as outlined within this document do not apply to chimney components or other non Vermont Castings, Majestic accessories used in conjunction with the installation of this product..
- Damage to the unit while in transit is not covered by this warranty but is subject to claim against the common carrier. Contact the dealer from whom you purchased your fireplace/stove (do not operate the appliance as this might negate the ability to process the claim with the carrier).
- The Company will not be responsible for:
 - a) Down drafts or spillage caused by environmental conditions such as near-by trees, buildings, roof tops, hills, or mountains.
 - b) Inadequate ventilation or negative air pressure caused by mechanical systems such as furnaces, fans, clothes dryers, etc.
- This warranty is void if:
 - a) The fireplace has been operated in atmospheres contaminated by chlorine, fluorine, or other damaging chemicals.
 - b) The fireplace has been subjected to prolonged periods of dampness or condensation
 - c) Any damages to the fireplace, combustion chamber, heat exchanger or other components due to water, or weather damage, which is the result of but not limited to, improper chimney/venting installation.
 - d) Any alteration, willful abuse, accident, or misuse of the product has occurred.

IF WARRANTY SERVICE IS NEEDED...

- 1) Contact your supplier. Make sure you have your warranty, your sales receipt, and the model/serial number of your Vermont Castings, Majestic product.
- 2) DO NOT ATTEMPT TO DO ANY SERVICE WORK YOURSELF.

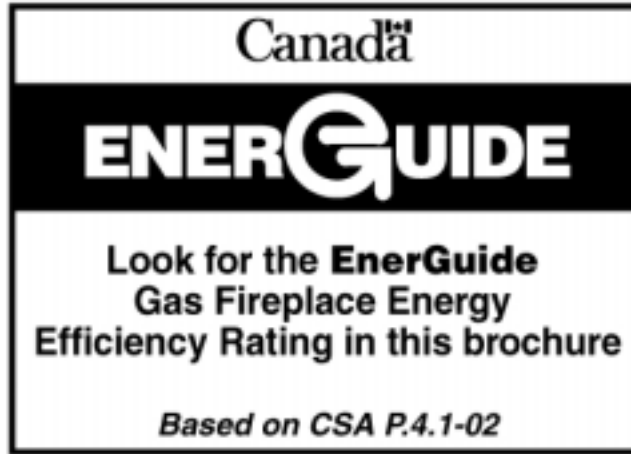

905-670-4349

Efficiency Ratings				
Model	EnerGuide Ratings Fireplace Efficiency (%)	Steady State (%)		D.O.E. (AFUE%)
		Fan-OFF	Fan-ON	
DV360RN	53	82	83	64
DV360RP	53	83	84	64
DV360RFN	53	82	83	64
DV360RFP	53	83	84	64
DV580RN	51.1	82	83	64
DV580RP	51.1	83	84	64
DV580RFN	51.1	82	83	64
DV580RFP	51.1	83	84	64

CozyCabin.com

Vermont Castings, Majestic Products

410 Admiral Blvd. • Mississauga, Ontario, Canada L5T 2N6 • 905-670-7777
 www.majesticproducts.com • www.vermontcastings.com