

# Consolidated Dutchwest Federal Convection Heaters

## General Instructions

For Use in North America

The following models are covered in this manual:

FA224 Model No. 2181

FA264 Model No. 2183

FA288 Model No. 2184



**SAFETY NOTICE: IF YOUR FEDERAL CONVECTION HEATER IS NOT PROPERLY INSTALLED, OPERATED AND MAINTAINED, A HOUSE FIRE MAY RESULT. FOR SAFETY, FOLLOW ALL INSTALLATION, OPERATION AND MAINTENANCE DIRECTIONS. CONTACT LOCAL BUILDING OFFICIALS ABOUT RESTRICTIONS AND INSTALLATION INSPECTION REQUIREMENTS IN YOUR AREA.**

Thank you for choosing a Consolidated Dutchwest Federal Convection Heater. Your stove is one of the finest and most technologically advanced available, and if treated properly and operated according to the guidelines in this manual will provide years of safe, dependable, and economical heating.

A Federal Convection Heater is unique because it delivers *convection heat* as well as *radiant heat*.

While most stoves give heat by radiating warmth directly from the hot stove surface, a Federal Convection Heater draws air into a series of chambers within the stove where it is heated before it flows back into the room. The convection of heated air from the stove takes advantage of the natural air flow patterns within your home, resulting in a more uniform distribution of heat throughout the house.

An optional Convection Heater Fan may be added to the stove to multiply the hot air flow by up to five times.

This manual describes the installation and operation of three Consolidated Dutchwest catalytic-equipped wood heaters: the *small* Federal Convection Heater, Model FA224, the *large* Convection Heater, Model FA264, and the *extra large* Model FA288. These heaters meet the U.S. Environmental Protection Agency's emission limits for wood heaters sold after July 1, 1990. Under specific test conditions these heaters have been shown to deliver heat at rates ranging as follows:

FA224	9,100-34,800 Btu's/Hr.
FA264	9,500-31,700 Btu's/Hr.
FA288	7,800-29,300 Btu's/Hr.

For more information on individual stove heat outputs and specifications, please refer to page 23.

In addition to directions on installation and operation, this manual includes directions on maintenance and assembly.

We recommend that you hire a professional solid fuel stove installer to install your stove, or to advise you on the installation should you attempt to install it yourself.

**Save These Instructions.**

# Operation

## Your Stove's Controls and What They Do

### *Three Air Controls Regulate The Heat And The Length Of Fire*

A Federal Convection Heater has three air controls that regulate the amount of air drawn into the stove. Generally, more air entering the stove makes the fire burn hotter and faster, while less air prolongs the burn. The air controls are operated with the multi-purpose door handle. They open when rotated counterclockwise and close when turned clockwise, and are located as follows:

The **Primary Air Control** is located on the side loading door and is the primary source of air for starting and maintaining the fire.

A **Combustor Air Control** is also located on the left side of the stove, above the side loading door, and delivers pre-heated air to a strategic internal site to aid catalytic combustion.

A **Coal-only Air Control** is positioned on the access door to the ash drawer compartment. The coal-only control is the primary air supply for starting and maintaining coal fires. This control must be closed completely when burning wood.

### *A Stove Damper Directs Air Flow Within The Stove*

The **Damper** is operated by moving the small, square knob on the left side of the stove. It has two positions: open, to start the fire, and closed, for greatest efficiency and heat. Using the multi-purpose door handle, rotate the handle counterclockwise to open it and clockwise to close it.

The stove damper must be open when starting a fire, when reloading fuel (for a short time only), and when opening either the side or front doors of the stove for any reason.

### *Two Doors For Fueling, And A View Of The Fire*

A **Side Loading Door** allows the easiest loading of wood logs, while **Double Front Doors** open for adding an occasional log to wood fires. The front doors also may be opened wide and the spark screen (included with the stove) placed in the opening for safe, fireplace-style viewing. When the front doors are closed, the fire may still be viewed through the optional **Ceramic Viewing Windows**.

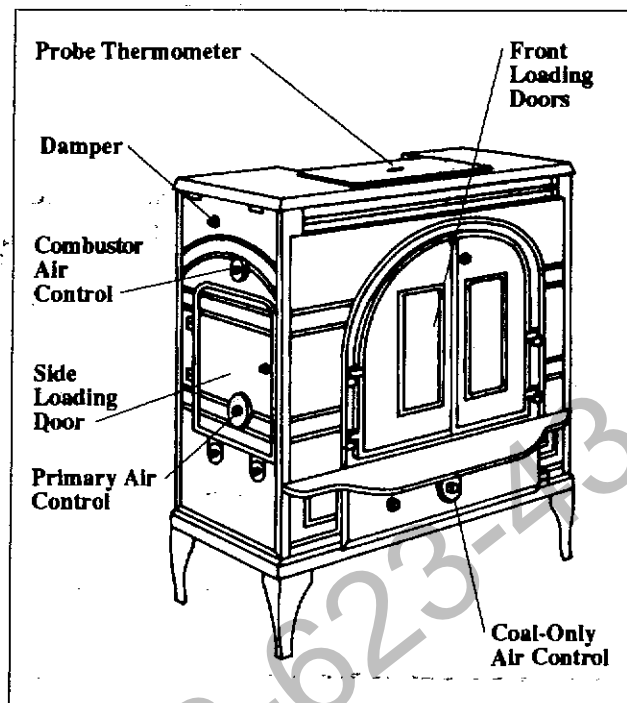

All stove controls are conveniently accessible and easy to regulate.

### *The Thermometer Is A Valuable Guide To Operation*

A **Top-Mounted Probe Thermometer** constantly provides a temperature reading that tells you when to increase or decrease the air supply, when to open or close the stove damper, whether the stove's catalytic combustor is working, and when to add wood.

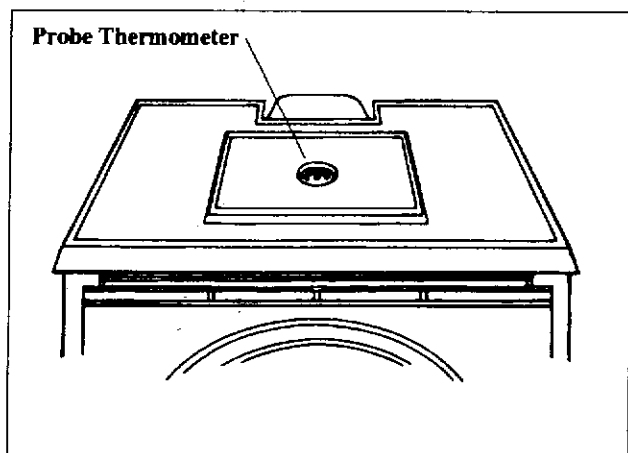

An optional probe thermometer gives temperature readings that help you to operate your stove safely and effectively, just as a speedometer is a guide to driving your car.

## Two Rules For Success

Burning wood is often said to be more of an art than a science. You'll easily master the art if you start by using good, dry fuel, and understand how the stove's air supply system operates.

## Burn Only High-Quality Fuel

This heater is designed to burn natural wood only; do not burn fuels other than those for which this heater was designed.

Higher efficiencies and lower emissions generally result when burning air-dried, seasoned woods as compared to softwoods or freshly cut hardwoods. Avoid burning "green" wood that has not been properly seasoned.

The best hardwood fuels include oak, maple, beech, ash, and hickory that has been split, stacked, and air-dried outside under cover for at least one year.

For areas that do not have a supply of hardwood, tamarack, yellow pine, white pine, Eastern red cedar, fir, and redwood are softwoods that are commonly burned. They too should be properly dried. The length of the wood should be the same as that specified for your particular stove.

Wood should be stored under cover to maintain dryness. Even for short-term storage, keep wood a safe distance from the heater and keep it out of the areas around the heater used for refueling and ash removal.

### Use The Air Control Control Settings That Work Best For You

No single combination of control settings will fit every situation. Each installation will differ depending on the quality of the fuel, the amount of heat desired, and how long you wish the fire to burn.

Control settings also depend on your particular installation's "draft," or the force that moves air from the stove up through the chimney. Draft is affected by such things as the length, type, and location of the chimney, local geography, nearby obstructions, and other factors.

Too much draft may cause excessive temperatures in the stove, and could even damage the combustor. On the other hand, too little draft can cause backpuffing into the room and/or the "plugging" of the chimney or combustor.

How do you know if your draft is excessively high or low? Symptoms of too much draft include an uncontrollable burn or a glowing-red part of the stove or chimney connector. A sign of inadequate draft is smoke leaking into the room through the stove or chimney connector joints.

When first using the stove, keep track of how many turns open you have set the controls. You will quickly find that a specific control setting will give you a fixed amount of heat. It may take a week or two to determine the amount of heat and the length of burn you should expect from various control settings.

Most installations do not require a large amount of combustion air, especially if adequate draft is available. Do not for any reason attempt to increase the firing of your heater by altering the air control adjustment range outlined

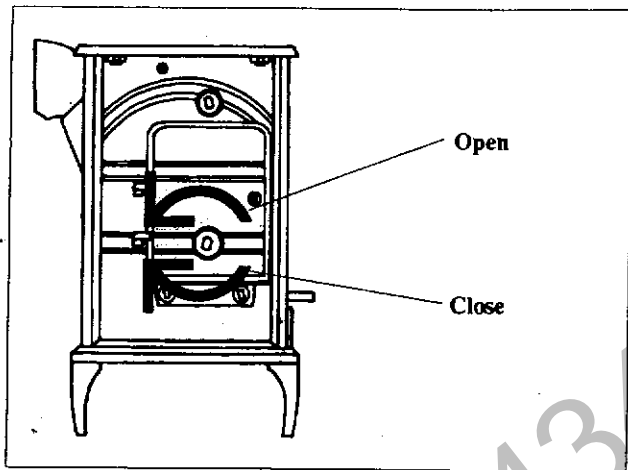

Spin-dial air controls provide precise regulation of the air entering the stove.

in these directions.

Use the following air control settings as a starting point to help determine the best settings for your installation:

#### FA224

<u>Burn Rate</u>	<u>Primary Air</u>	<u>Combustor Air</u>
Low	1/2 turn	2 turns
Med./Low	3/4 turn	2-1/2 turns
Med./High	1-1/2 turns	3-1/2 turns
High	Maximum turns	Maximum turns

#### FA264

<u>Burn Rate</u>	<u>Primary Air</u>	<u>Combustor Air</u>
Low	3/4 turn	2 turns
Med./Low	1 turn	2-1/2 turns
Med./High	1-1/2 turns	3-1/2 turns
High	Maximum turns	Maximum turns

#### FA288

<u>Burn Rate</u>	<u>Primary Air</u>	<u>Combustor Air</u>
Low	2/3 turn	2 turns
Med./Low	1-1/2 turn	3 turns
Med./High	2-1/2 turns	Maximum turns
High	Maximum turns	Maximum turns

If your stove is equipped with an optional blower, follow these guidelines as well for best results:

• At low to medium heat outputs, (less than 1-1/2 turns primary air) the optional convection blower switch should be set at the "low" position.

• At medium high to high heat outputs, (equal to or greater than 1-1/2 turns primary air) the blower switch should be set at the "high" position.

**NOTE: THE COAL-ONLY AIR CONTROL MUST ALWAYS BE CLOSED DURING A WOOD FIRE.**

**DO NOT OPERATE THE STOVE WITH THE ASH DOOR OPEN. THIS CAN CAUSE EXTREME OVERFIRING OF THE STOVE, WHICH IS DANGEROUS.**

The stove's paint and cement will emit a slight odor during the first few fires. We suggest that you provide extra ventilation near the stove by partially opening a door or window when the odor is present.

## How To Build A Wood Fire And Keep It Going

### *Make Sure Your Stove Is Set Up Correctly For Burning Wood*

A Federal Convection Heater leaves the factory with the combustor installed.

In The United States, it is against the law to operate this wood heater in a manner inconsistent with operating instructions in this manual, or if the catalytic combustor is deactivated or removed.

The grate covers are also installed. These are necessary for wood burning and should be left in place.

### *High-Efficiency Heating With Catalytic Combustion*

Smoke from a wood fire is really escaping energy that has not been burned to produce heat. Combustion temperatures of 1100° F. (595 C.) are required to burn the smoke, and a level this high seldom is present in a fire set to burn several hours. As a result, long fires in conventional stoves lose a great deal of potential heat up the chimney as smoke.

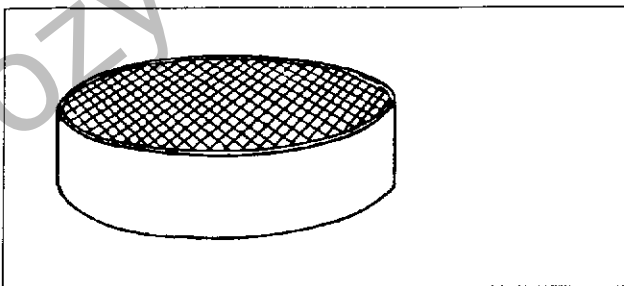

High-efficiency performance when burning wood is a result of a catalytic combustor that is coated with precious metals to cause smoke to burn at temperatures lower than normal.

A catalytic combustor captures this heat by lowering the temperature at which smoke will burn. This makes high efficiency possible even with long, low-level fires.

Catalytic combustion is activated with two adjustments: by closing the stove damper, thereby exposing the smoke to the combustor, and by opening the combustor air control. The combustor needs extra air during medium and high burns, and the combustor air control must be adequately open to supply it: 3-1/2 turns for the FA 224 and FA 264, and the maximum for FA 288. During low burns, the combustor air control should be open only two turns.

Closing the stove damper also reduces the draft, so to avoid putting out the fire or deactivating the combustor, close the damper only when a fire is well-established. When starting a fire, let it run at least 15-20 minutes before closing the stove damper.

Never kindle a fire with colored paper or paper that has colored ink or a glossy surface, and never burn treated wood, garbage, solvents, colored paper, or trash. All of these may poison the catalyst and prevent it from operating properly. Never burn cardboard or loose paper except for kindling purposes, and do not burn coal when the combustor is installed; doing so can produce soot or large flakes of char or fly ash that can coat the combustor. This can cause smoke to spill into the room and effect combustor operation.

In general, the temperature in the stove and the gases entering the combustor must be raised to approximately 800° F. (430 C.) degrees to ensure that catalytic activity is initiated. During the start-up of a cold stove, a medium- to high- firing rate must be maintained for about twenty minutes. This ensures that the stove, catalyst, and fuel are all stabilized at the proper operating temperatures.

Even though it is possible to have gas temperatures reach several hundred degrees within two to three minutes after a fire is started, the combustor may stop working or the fire may go out if the fire is allowed to die down immediately. Once the combustor starts working, heat generated by burning the smoke will keep it working.

The best operating range for the combustor is a reading of 1000-1400° F. (540-760 C.) on an optional probe thermometer. Temperatures over 1700° F. (925 C.) may damage the combustor.

To determine whether the combustor is operating, check the probe thermometer in the top of the stove. If it reads 800° F. (430 C.) or higher, it is likely that the combustor is operating. If temperatures are lower than this, increase the intensity of the fire either by adding fuel or by increasing the amount of primary air.

### *Starting And Maintaining A Wood Fire*

All three Federal Convection Heaters load wood from both front and side. Loading from the front is useful for kindling a new fire and adding an occasional log, but we recommend side loading as the most convenient way of adding several logs at a time.

When burning wood, your Federal Convection Heater may be operated with the front doors open for fireplace-style viewing as well as closed. Always be certain that the stove damper is open when the doors are open, and always use the firescreen that was provided with your stove for

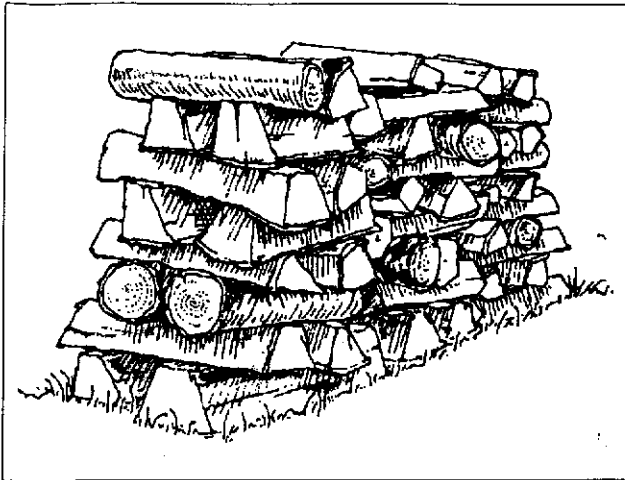

The best wood is air-dried outside for at least a year.

fire viewing.

**WARNING: OPERATE YOUR FEDERAL CONVECTION HEATER MODEL FA224, FA264, OR FA288 ONLY WITH THE DOORS FULLY OPEN OR DOORS FULLY CLOSED**

**STEP 1.** Open the stove damper, and open the primary air control fully. Open the combustor air control two turns. The coal-only air control must always be closed during wood burning.

**STEP 2.** Lay some crumpled newspapers in the stove. Place six or eight pieces of dry kindling split to a finger-width size on the paper, and on the kindling lay two or three larger sticks of split dry wood approximately 1-2" (25-50 mm).

**DO NOT USE CHEMICALS OR FLUIDS TO START THE FIRE. DO NOT BURN GARBAGE OR FLAMMABLE FLUIDS SUCH AS GASOLINE, NAPHTHA, OR ENGINE OIL.** Also, never use gasoline-type lantern fuel, kerosene, charcoal lighter fluid, or similar liquids to start or "freshen up" a fire in this heater. Keep all such liquids well away from the heater while it is in use.

**STEP 3.** Light the newspaper and close the door. Within 10-15 minutes the fire should be well-established and you may gradually build it up by adding a few sticks at a time of a progressively larger size. Continue the build-up until you have a live coal bed 3-4" (150-200 mm) thick.

You'll soon find out that this stove is **HOT WHILE IN OPERATION! KEEP CHILDREN, CLOTHING, AND FURNITURE AWAY. CONTACT MAY CAUSE SKIN BURNS.**

**NOTE:** Some chimneys need to be "primed," or warmed up, before they will draw sufficiently to start a fire. To correct this situation, roll up a couple pieces of newspaper, place them on top of the kindling and toward the back of the stove, light them, and close the doors. This should heat the chimney enough to initiate a draft.

Once the draft is established, open the front doors and light the rest of the fuel from the bottom. Do not light the main bed of fuel until the chimney begins drawing, and repeat the procedure as often as necessary if the initial attempt is unsuccessful.

**STEP 4.** After the temperature on the probe thermometer has reached 450-500° F. (232-260 C.), close the stove damper. This will activate the combustor. To ensure continued operation of the combustor, let the temperature approach at least 850° F. (454 C.) before reducing the air settings.

**STEP 5.** Close the primary air control to a medium low setting: about 3/4 turn open for the FA224, 1 turn open for the FA264, and 1-1/2 turn open for the FA288. The fire volume will diminish immediately, but the stove will continue to warm up. Maintain control of the fire using the primary air and combustor air controls, and remember: reduce the setting for a smaller fire, increase the setting for a larger fire. Refer back to the air control settings chart on pages 4 and 5 for recommended settings for your particular model at different burn rates.

**DO NOT OVERFIRE THIS HEATER.** Overfiring may cause a house fire, or can result in permanent damage to the stove and to the catalytic combustor. If a part of the stove or the chimney connector glows, you are overfiring.

### *Reloading and Reviving a Wood Fire*

Open the stove damper and wait at least fifteen seconds for the draft to increase. Open the door slowly, and add the fuel. Split wood will fill the firebox more completely and reduce the frequency of reloading.

Leave the stove damper open for a short time until the probe temperature reaches 800° F. (430 C.), then close it.

Frequently the temperature will drop below 800° F. (430 C.) after reloading, particularly if the loading door is open a long time. Should the temperature drop below this level, or if the charcoal bed is low, stimulate the fire by increasing the primary air supply while leaving the stove damper open. Reduce the air supply and close the stove damper when the temperature has reached 800° F. (430 C.).

**NOTE:** If the charcoal bed is relatively thick and your fuel is well-seasoned, it is possible to add fresh fuel (smaller pieces first), close the door and damper, and reset the air control within five minutes.

### *Remove And Store Ash Safely*

Check the ash pan before reloading the stove. If the ashes are close to the top, empty the pan. Before replacing the ash pan, clear away any ash that has spilled over the sides and back of the ash pan.

Empty the ash drawer regularly, typically every one to

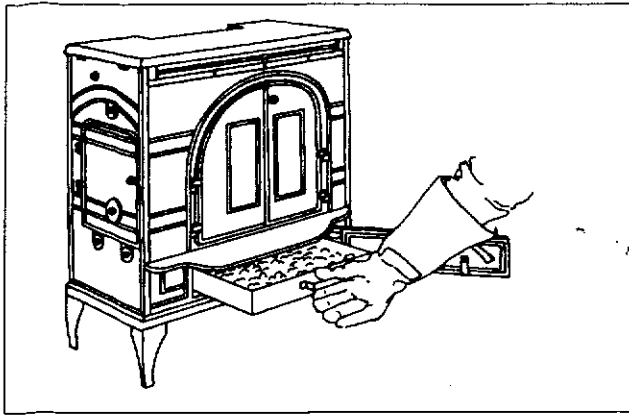

Always wear a heavy stove glove when removing the ash drawer to empty ashes.

three days. The frequency will vary depending on how hot you run your stove: the hotter the fire, the more wood you burn, and the faster ash will accumulate.

Ash may contain hot coals and must be treated with extreme care.

### *Always Dispose of Ashes in a Safe Manner*

Ashes should be removed frequently and placed outdoors in a metal container with a tight-fitting lid. The closed container of ashes should be placed on a noncombustible floor or on the ground, well away from all combustible materials, pending final disposal. If the ashes are disposed of by burial in soil or otherwise locally dispersed, they should be retained in the closed container until all cinders have thoroughly cooled. Wood ash may be used as a garden fertilizer.



Hot ashes can be dangerous, and must be stored outdoors on a non-combustible surface in a metal container with a tight-fitting lid.

**CAUTION:** Never use a vacuum cleaner to remove ash from the stove; always remove and dispose of the ashes properly.

## Maintenance

### Keep Your Stove Looking New And Working Its Best

#### *Care of The Cast Iron Surface*

An occasional dusting with a dry rag will keep the painted cast iron of your Federal Convection Heater looking new.

If the paint needs retouching, allow the stove to cool completely. Wire-brush areas needing to be painted. Remove non-painted components such as air controls or cover them with masking tape. Touch up the stove with high temperature stove paint available from your local dealer. Apply the paint sparingly. Two light coats are better than one heavy one.

#### *Cleaning The Glass*

If you have installed the optional glass door kit you will find that most of the carbon deposits on the glass will burn off regularly during hot fires. If you wish to clean the glass more thoroughly, follow this procedure:

- Be sure the glass is completely cool.
- Use a glass cleaner especially made for this purpose
- Dry the glass completely.

### Repair Air Leaks To Prevent Overheating

#### *Self-Adjusting Door Latches*

A tight seal of the doors ensures precision control over the firing rate, and prevents inadvertant overfiring. The self-adjusting design of your stove's door latch enables you to control the tightness of the seal each time you close the door.

To achieve greater tightness, turn the handle more in a counter-clockwise direction. Each movement of the handle draws the door closer to the stove.

Don't use excessive force when tightening the door latch. A tight seal is made when only moderate pressure is applied to the handle.

#### *Test And Repair The Door Gaskets*

To find low spots in door gasketing that may allow too much air into the stove, close each door on a slip of paper and attempt to pull the paper free. If the paper is freed without tearing, the gasket isn't snug enough at that spot.

If the door will not tighten sufficiently with additional

turning of the handle, try "adjusting" the gasket in the area needing attention. Pack more cement or a smaller diameter gasket into the channel beneath the gasket to shim it so that the main gasket is raised and makes contact with the door frame.

This procedure should solve the problem. If it doesn't, replace the gasket following these steps:

- Remove the original gasket by grasping an end and pulling firmly.
- Wearing safety goggles, use a wire brush or the tip of a screwdriver to clean the channel of any remaining cement or bits of gasket.
- Apply a thin bead of stove cement in the newly-cleaned groove.
- Pack the gasket into the groove. Wait until you are a couple inches from the end before you cut it.

Test the gasket by closing the door on a slip of paper as described above. Adjust the gasket in any areas where an inadequate seal is evident.

All rope-type gasketing used in the Federal Convection Heaters is made of fiberglass. The gasketing is 1/2" diameter for front and side doors and the ash door, 3/8" for the catalytic combustor, and 7/16" for the top plate.

### **Repair Missing Cement In Seams**

The cement in the stove seams may deteriorate over time and fall out in places. Just as with the stove doors, it is necessary to keep the seam seals in good condition. Spot-fix with furnace cement (available from your local dealer) any areas where the cement seal is visibly deteriorated. Allow 24 hours for the new cement to dry after "washing down" seams.

### **Avoid Damaging The Glass Door Panels**

If you have equipped your stove with optional glass door panels, do not abuse them by slamming the doors shut or striking the glass with a piece of wood, and never operate your stove if it has damaged or broken glass. If you need to replace the glass, use only glass provided by Consolidated Dutchwest. Instructions for glass replacement are provided with the replacement kit.

## **Care Of The Catalytic Combustor**

This wood heater contains a catalytic combustor, which needs regular inspection and periodic replacement for proper operation. It is against the law in the United States to operate this wood heater in a manner inconsistent with operating instructions in this manual, or if the catalytic element is deactivated or removed.

Under normal operating conditions, the catalytic combustor should remain active for two to six years (depending on the amount of wood burned). However, it is important to

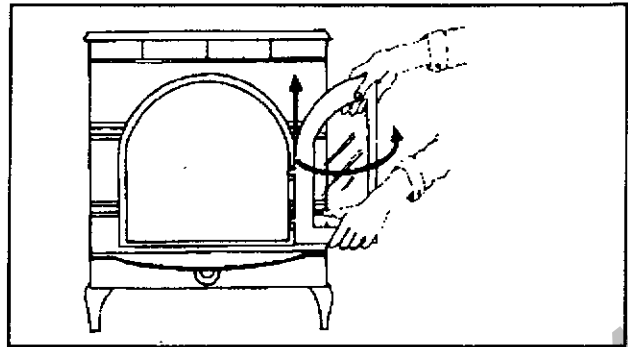

To replace the door gaskets, first remove the door by lifting and rotating at the same time.

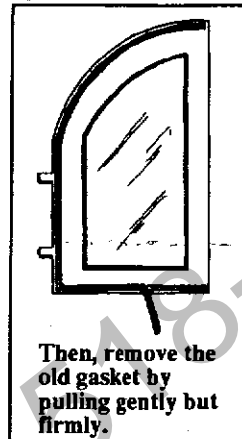

Then, remove the old gasket by pulling gently but firmly.

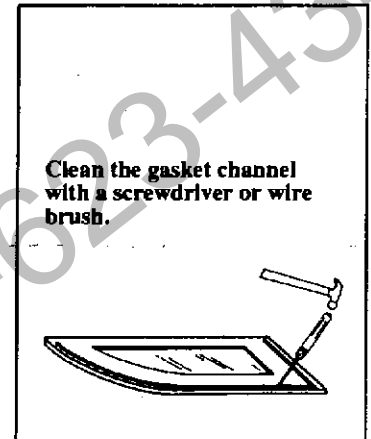

Clean the gasket channel with a screwdriver or wire brush.

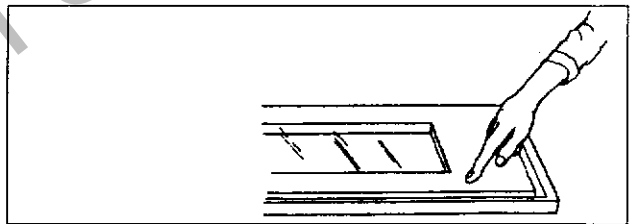

Apply a thin bead of fresh cement to the channel and install the new gasket.

monitor the combustor periodically to ensure that it is functioning properly, as well as to determine when it needs to be replaced. A non-functioning combustor will result in a loss of heating efficiency, and an increase in creosote and emissions.

The combustor should be visually inspected "in place" for fly ash accumulation and physical damage three times per year. Actual removal of the combustor is not recommended unless a more detailed inspection is warranted because of diminished performance as outlined below.

The refractory package housing the catalytic combustor should be inspected annually for a build-up of fly ash and cleaned if necessary. This may be done during examination of the catalytic combustor.

### **When To Suspect A Combustor Problem**

There are two ways to evaluate the performance of your stove's combustor. The first is to monitor the temperatures recorded on the probe thermometer. A properly-functioning combustor should operate regularly in the range of 800-1200° F. (430-650 C.). Combustor temperatures consistently less than 800° F. (430 C.) merit a closer



examination of the combustor.

The second performance test is to observe the amount of smoke leaving the chimney — both when the combustor has achieved "light-off" and when it has not. Follow this simple two-step procedure:

- With a fire in the stove and the combustor properly activated by the closing of the stove damper to route smoke through it as described in the Operation Section, go outside and observe the smoke leaving the chimney.
- Then, open the stove damper and once again observe the smoke leaving the chimney.

Significantly more smoke should be observed after the second step when the stove damper is open and exhaust is not routed through the combustor. Be careful not to confuse smoke with steam from wet wood, however!

If either of these tests indicates a problem, consider other possible factors as well.

Assess your present operating conditions. In Spring or Fall, draft strength is less than in the middle of winter, and a related change in stove performance may result. Small hot fires are a good solution to sluggish performance under these conditions.

Burning "green" (insufficiently seasoned) wood will result in poorer performance than when burning properly seasoned fuel. Was your fuel supply good and dry to start with, or has it changed? You may have to run your stove hotter (more air) to achieve good performance if you are burning green or wet wood. Also, any changes in operating routine should be considered at this time as a possible reason for changed performance.

Once you have ruled out any other possible causes for a decline in performance, you may proceed with an inspection of the catalyst.

### Remove And Inspect The Combustor

- Before you begin, observe the basic safety precautions for working with dusty materials: always wear safety glasses, a dust mask, and gloves.

- Remove the four bolts that secure the stove top plate. There are two each on both the left and the right side, just under the top plate overhang. With the bolts removed, lift the top. The combustor is located beneath the removable refractory package.

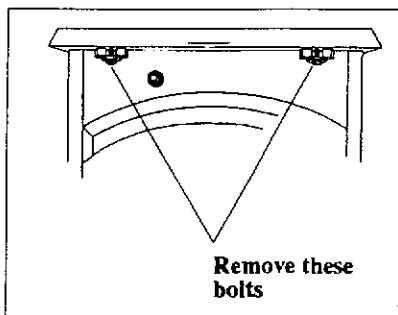

To reach the catalytic combustor for inspection or removal, remove two bolts on each side of the stove.

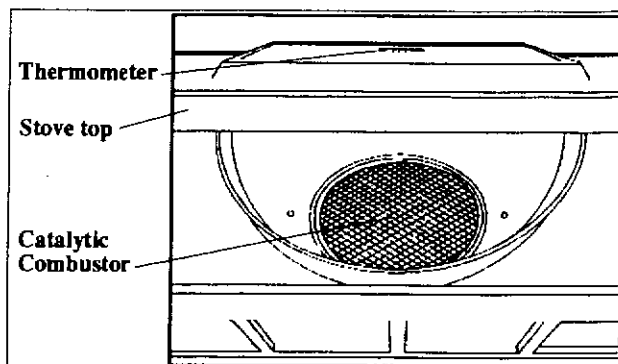

Lift the stove top, and the combustor is within easy reach.

- Carefully remove the refractory package. It is extremely delicate and should be handled as little as possible.
- For a visual inspection for blockage that can be performed without removing the combustor, have an assistant shine a bright flashlight beam up through the combustor from inside the stove's firebox.
- If combustor removal is necessary for cleaning or closer inspection, lift it gently out of its chamber. You may have to work it back and forth carefully to remove it. Check the combustor and the bottom of the refractory chamber for a build-up of fly ash, and remove any ash by gently blowing air through the combustor. Do not brush the surface, as this could damage the element.
- Inspect the combustor, referring to the information in the "Catalytic Combustor Appendix" on page 26 for information on what to look for. Although small hairline cracks will not affect performance, the combustor should be essentially intact. If the combustor is broken in pieces or has sections missing, it should be replaced. Call your local Consolidated Dutchwest dealer for a replacement combustor, item #CB56. Consult the warranty section at the back of this manual for further information on catalytic combustor replacement.
- If the combustor is in good condition and clean, re-install it. Be sure first to carefully wrap a new Interam gasket (an extra was provided with your stove) around its perimeter before replacement. Insert the gasketed combustor gently back into position, and replace the refractory package.

- Before replacing the stove top, check the damper. If the gasket is intact, but the damper isn't locking tightly, adjustment should be made. Also check the gasket that seals the top plate.

- Gasket should be replaced only if damaged or missing. The top plate uses a 7/16" gasket and the damper is sealed with a 3/8" gasket. The procedure for removing the old gasket and installing the new is the same as that described for door gaskets on page 9.

- Replace the stove top, and tighten the four top plate bolts that secure it. Be sure that the top plate seats properly before tightening, and tighten the bolts alternately as you would tighten the bolts that secure a car tire.

### Watch For Better Results

Finish up by cleaning the chimney and chimney connector. Then, operate the stove in a typical manner for two weeks and observe the stove's performance, taking particular note of the performance tests described above.

If a problem persists, contact your Consolidated Dutchwest dealer for further advice about your particular situation.

## A Clean Chimney System Is Safer And Works Better

### Learn To Recognize — And Avoid — Creosote

Inspect the chimney and chimney connector at least twice monthly, and clean if necessary.

When you first begin using the stove, check daily for creosote — a substance that can look like either thick tar or black, crisp flakes. Experience will show how often you need to clean to be safe. The frequency may even vary during the year. In the colder months when the hottest fires producing the least creosote are burned, you may need to clean only every couple of months. During the warmer months when creosote is more likely to result from cooler-burning fires, weekly cleaning may be necessary.

At the very least, the chimney connector and chimney should be inspected at least once every two months during the heating season to determine if a buildup of creosote or soot has occurred. If a significant layer of creosote has accumulated (1/8" [3 mm] or more), or if soot has accumulated, either should be removed to reduce the risk of a chimney fire. Failure to keep the chimney and connector system clean can result in a serious chimney fire.



The conditions for a chimney fire develop like this: When wood is burned slowly, it produces tar and other organic vapors, which combine with expelled moisture to form creosote. The creosote vapors condense in the relatively cool chimney flue of a slow-burning fire. As a result, creosote residue accumulates on the flue lining. When ignited, this creosote makes an extremely hot fire within the flue system which can damage the chimney and overheat adjacent combustible material.

To reduce the amount of creosote that may form, remember to provide adequate air for combustion and to strive for small, intense fires rather than large, smoldering ones.

You can never be too safe. Contact your local fire author-

ity for information on what to do in the event of a chimney fire, and have a clearly understood plan on how to handle one.

### Inspect Regularly, Clean As Required

Inspect the chimney and chimney connector twice monthly and clean if necessary. Let the stove cool completely before you inspect the chimney. Then, using a strong light, sight up through the flue collar into the chimney flue. If it is not possible to inspect the flue system in this fashion, the stove must be disconnected to provide adequate viewing.

Clean the chimney using a specially designed chimney cleaning brush, the same size and shape as the flue liner, attached to flexible fiberglass rods designed for this purpose. Run the brush up and down the liner so that any deposits fall to the bottom of the chimney where they can be removed through the clean-out door. The chimney connector should be cleaned by disconnecting the sections, taking them outside, and removing any deposits with a stiff wire brush. Reinstall the connector sections after cleaning, being sure to secure the individual sections with three sheet metal screws per section.

If you are unable to inspect and/or clean the chimney system yourself, contact your local Consolidated Dutchwest dealer or hire a qualified chimney sweep in your area to do the job.

## Federal Convection Heater Maintenance Schedule

### STOVE:

#### DAILY:

- Ashes should be removed before they reach the top of the ash pan. Check at least once a day.
- Keep the area around the stove clear of any combustible material.

#### TWO MONTHS:

- Inspect the catalytic combustor. Clean if necessary.
- Check door handle to be sure it is working properly. Gasketing becomes compressed after a period of time. Adjust handle tightness if necessary.
- Check leg bolts and heat shield screws; tighten if necessary.

#### YEARLY SPRING CLEANING:

- Check gasketing for wear, and replace if necessary.
- Remove ashes from the ash pan and replace with a moisture absorbing material (such as kitty litter) to keep the interior of the stove dry.
- Inspect and clean the refractory package.
- Clean the dust from the inner sides of bottom, rear or pipe heat shields if your stove is equipped with them. Clean surfaces are better heat reflectors than dirty surfaces.
- Touch up the black paint.

### CHIMNEY CONNECTOR:

#### TWO WEEKS:

- Inspect the chimney connector and chimney. Clean if necessary.

### TWO MONTHS:

- Inspect the chimney and chimney connector. Pay particular attention to the horizontal runs of chimney connector, and the elbows. Clean the system if necessary.

### YEARLY SPRING CLEANING:

- Disassemble the chimney connector and take it outdoors for inspection and cleaning. Replace weak sections of connector.
- Inspect the chimney for signs of deterioration. Repairs to a masonry chimney should be made by a professional mason. Replace damaged sections of prefabricated chimney. Your local Consolidated Dutchwest dealer or a chimney sweep can help determine when replacement is necessary.
- Thoroughly clean the chimney.

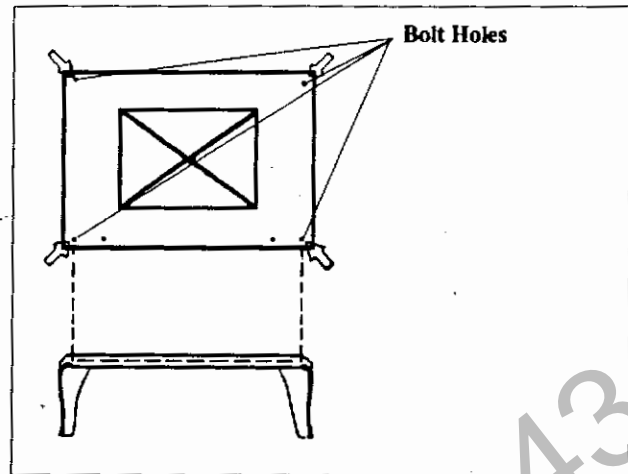

Four bolts in the stove bottom are used to secure the stove legs and heat shield brackets in each corner.

## Assembly Instructions

### Federal Convection Heater Models 2181, 2183, and 2184

Your convection heater requires some assembly. Follow the directions carefully, and refer to the parts diagram at the back of this manual if you need a picture of where the various parts fit.

#### Unpack The Parts

Remove all loose parts from the firebox and the ash pan. Check to make sure all the parts are included and intact. You should have received:

- 1 fully assembled heater body
- 1 firescreen
- 4 legs
- 1 bottom heat shield \*
- 1 ash pan
- 1 catalytic combustor (installed in its chamber below the stove top)
- 1 box of assorted parts:
  - 1 brass handle assembly
  - 1 door handle spring insert
  - 4 steel brackets for bottom heat shield
  - 1 bag of hardware used for assembly, including the following:

- To attach the chimney connector to the flue collar:
  - (3) #10 x 1/2" sheet metal screws
- For tightening the door latch:
  - (1) Allen wrench, 5/32" length
- To attach the legs to the stove:
  - (4) 1/4-20 x 1" hex head bolts
  - (4) 1/4" washers
- Also...
  - (1) door handle spring, which fits inside the

square socket in the iron part of the door handles, and will push the handle off the stove in case you forget to remove it after closing the stove doors. This keeps the handles from getting hot.

\*Heat shields are standard only on stoves sold in Canada.

If any parts are missing or damaged, immediately notify your Consolidated Dutchwest dealer for replacements. Do not install your stove without having all necessary parts or by using damaged parts.

#### Attach The Legs And Heat Shield

Place the stove on its back on a soft surface such as a couple of old blankets. Tilt it carefully; it's heavy. Protect surrounding carpeting with an old blanket or sheet.

First install the bottom heat shield if required.\* Using the bolts threaded into each corner of the stove bottom, bolt one bracket and one leg into each corner of the stove. The bracket should be below the leg's top portion.

Next, use the four bolts provided to attach the bottom heat shield to the brackets. Tighten the leg bolts and the bracket bolts firmly, and raise the stove onto its legs.

#### Install The Fittings

Insert the optional catalytic probe in the round space in the center of the stove top. With some versions of the probe, a small sleeve is provided to set into the hole before putting the probe in place.

Before inserting the probe, gently clear a path for it through the refractory that covers the combustor by inserting a 1/4" drill bit in the hole and rotating it with your fingers.

Your stove has been shipped with grate covers installed. These must be installed when burning wood.

The hardware in your stove is in standard US sizes. Most bolts are 1/4"-20, with 7/16" heads. Some of the hex-head bolts have metric heads. Use either a 3/8" (10 mm) wrench, or an 8 mm. wrench, or pliers if you're attaching a blower to the stove.

The multi-purpose brass handle will operate the three air controls, the doors, and the stove damper.

## Installation

### Stove Installations Must Be Safe And Legal

**SAFETY NOTICE: IF YOUR FEDERAL CONVECTION HEATER IS NOT PROPERLY INSTALLED, OPERATED AND MAINTAINED, A HOUSE FIRE MAY RESULT. FOR SAFETY, FOLLOW ALL INSTALLATION, OPERATION AND MAINTENANCE DIRECTIONS. CONTACT LOCAL BUILDING OFFICIALS ABOUT RESTRICTIONS AND INSTALLATION INSPECTION REQUIREMENTS IN YOUR AREA.**

Before you begin an installation, review your plans to see that:

- Your stove and chimney connector will be far enough from combustible material to meet all clearance requirements.
- The floor protector is large enough and is constructed properly to meet all requirements.
- You have all necessary permits from local authorities.

Your local building official is the final authority for approving your installation as safe and determining that it meets local and state codes.

The metal label permanently attached to the back of every Consolidated Dutchwest stove indicates that it has been tested to current UL and ULC standards, and gives the name of the testing laboratory. Clearance and installation information is also printed on the label. Local authorities generally will accept the label as evidence that, when the stove is installed according to the information on the label and in this manual, the installation meets codes and can be approved.

Codes vary in different areas, however. Before starting the installation, review your plans with the local building authority. Your local dealer can provide any additional information needed.

For any unresolved questions about installation, refer to the National Fire Protection Association's publication

*ANSI/NFPA 211-1988 Standard for Chimneys, Fireplaces, Vents and Solid Fuel Burning Appliances.* In Canada, the equivalent publication is *CSA CAN-B365, Installation Code for Solid Fuel Burning Appliances and Equipment.* These standards are the bases for many national codes. They are nationally recognized and are accepted by most local authorities. Your local dealer or your local building official may have a copy of these regulations.

**Important:** Failure to follow these installation instructions may result in a dangerous situation, including a chimney or house fire. Follow all instructions exactly, and do not allow makeshift compromises to endanger property and personal safety.

### What Kind Of Chimney To Use

Your Federal Convection Heater may be connected either to a sound masonry chimney that meets local codes, a relined masonry chimney that meets local codes, or to an approved prefabricated metal chimney. Whatever kind you use, the chimney and chimney connector must be in good condition and kept clean.

If you use an existing masonry chimney, it must be inspected to ensure safe condition before the stove is installed. Your local professional chimney sweep, building inspector, or fire department official will be able either to make the inspection or to direct you to someone who can.

The chimney should extend at least 3' (900 mm) above the highest point where it passes through a roof, and at least 2' (600 mm) higher than any portion of a building within 10' (3 m).

For proper draft and good performance, any chimney used with a Federal Convection Heater should extend at least 16' (5 m) above the flue collar of the stove.

### Masonry Chimneys

An inspection of the chimney must confirm that it has a lining. Do not use an unlined chimney. The chimney should also be examined for cracks, loose mortar, other signs of deterioration, and blockage. Repair any defects before the chimney is used with your stove.

Unused openings in an existing masonry chimney must be sealed with masonry to the thickness of the chimney wall,

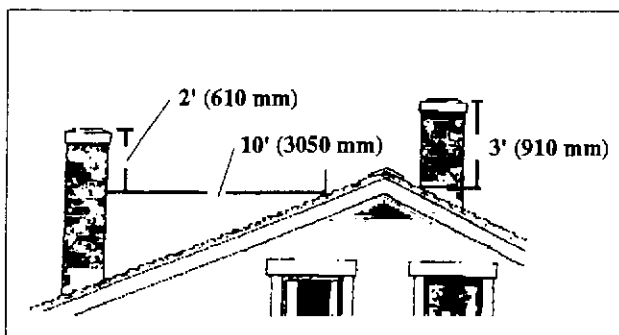

The 2/3/10 rule for chimneys

and the chimney liner should be repaired. Openings sealed with pie plates or wallpaper are a hazard and should be sealed with mortar or refractory cement. In the event of a chimney fire, flames and smoke may be forced out of these unused thimbles.

The chimney should be thoroughly cleaned before use.

A newly-built masonry chimney must conform to the standards of your local building code or, in the absence of a local code, to a recognized national code. Masonry chimneys must be lined, either with code-approved masonry or pre-cast refractory

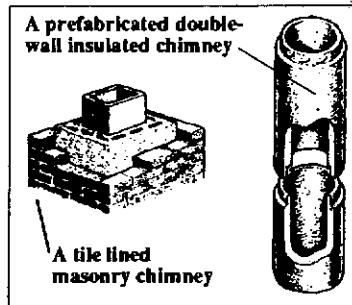

When in sound condition and approved for use, either a masonry or a prefabricated chimney may be used.

#### WARNING:

**DO NOT USE DOUBLE-WALL CHIMNEY CONNECTORS WITH FEDERAL CONVECTION HEATER MODELS FA224, FA264, and FA288, UNLESS THEY HAVE BEEN SPECIFICALLY TESTED AND LISTED FOR USE WITH THIS APPLIANCE. USE OF DOUBLE-WALL CHIMNEY CONNECTORS WHICH HAVE NOT BEEN TESTED AND LISTED FOR USE WITH FEDERAL CONVECTION HEATER MODELS FA224, FA264, and FA288 MAY RESULT IN TEMPERATURES EXCEEDING THE LIMITS ESTABLISHED BY THE TEST STANDARDS ANSI/UL-1482 OR ULC S627. A POTENTIAL HAZARD MAY RESULT, INCLUDING A HOUSE FIRE.**

tiles, stainless steel pipe, or a code-approved, "poured-in-place" liner. The chimney's clean-out door must seal tightly.

#### Prefabricated Chimneys

A prefabricated metal chimney must be one tested and listed for use with solid-fuel burning appliances to the High-Temperature (H.T.) Chimney Standard UL-103-1985 (2100° F.) for the United States, and High Temperature (650 C.) Standard ULC S-629 for Canada.

**DO NOT CONNECT THIS UNIT TO A CHIMNEY FLUE SERVING ANOTHER APPLIANCE.**

#### Chimney Size

Vent Models FA224 and FA264 into a masonry chimney with a nominal flue size of 8" x 8" (200 x 200 mm), and into a round flue size of 6" (150 mm).

Model FA288 requires a masonry chimney with a minimum nominal flue size of 8" x 8" (200 x 200 mm) or an 8" (200 mm) round chimney flue.

Chimneys with liners larger than 8" x 12" (200 x 300 mm) may experience rapid cooling of smoke and reduction in draft, especially if they are located outside the home. These large chimneys may need to be insulated or have their flues relined for proper stove performance.

Accessories to help make the connection between stainless steel chimney liners and your Federal Convection Heater are available through your local dealer.

## Guidelines For Installing The Chimney Connector

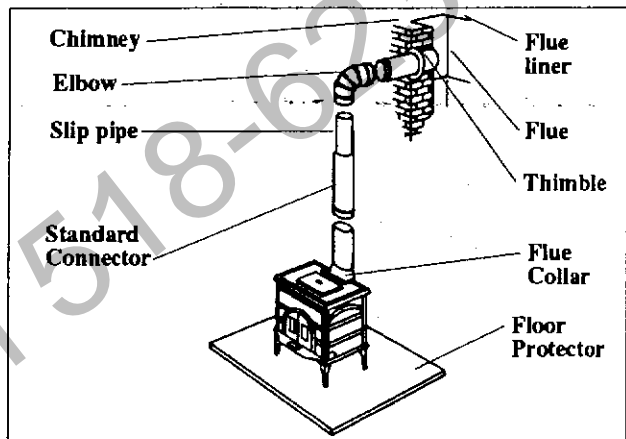

Sections of a steel chimney connector of at least 24 gauge thickness are fastened together with screws to connect the stove to the chimney.

Chimney connector is the single-wall pipe that connects the stove to the chimney. The chimney itself is a masonry or prefabricated structure that encloses the flue. Chimney connectors are used only to make the connection from the stove to the chimney.

Do not pass the chimney connector through a combustible wall or ceiling, or through an attic, a closet or any similar concealed space. If passage through a combustible wall is unavoidable, follow the recommendations in the section following on Wall Pass-Throughs.

The chimney connector should be made of 24 gauge or heavier steel, and must be 6" (150 mm) in diameter for models FA224 and FA264, and 8" (200 mm) for model FA288.

Install the chimney connector not less than 18" (450 mm) from the ceiling. Keep it as short and direct as possible, with no more than two 90 degree turns. Slope horizontal runs of connectors upward 1/4" per foot (20 mm per metre) going from the stove toward the chimney. The recommended maximum length of a horizontal run is 3 feet (1 metre), and the total length of chimney connector should be no longer than 8 feet (2.5 metres).

In cathedral ceiling installations, extend the prefabricated chimney downward to within 8 feet (2.5 metres) of the stove. The whole chimney connector should be exposed and accessible for inspection and cleaning.

Do not use galvanized chimney connector; it cannot withstand the high temperatures that can be reached by smoke and exhaust gases, and may release toxic fumes under high heat.

### Assembling The Chimney Connector

**SAFETY NOTE:** Always wear gloves and safety goggles when drilling, cutting or joining sections of chimney connector.

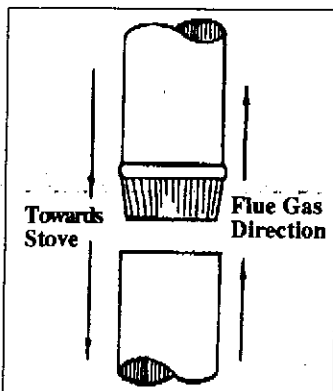

Crimped sections always point toward the stove so that any liquid condensation will not leak out.

- Beginning at the flue collar of the stove, assemble the chimney connector. Insert the first crimped end into the stove's flue collar, and keep each crimped end pointing toward the stove. Using the holes in the flue collar as guides, drill 1/8" (3 mm) holes in the bottom of the first section of chimney connector and secure it to the flue collar with three #10 x 1/2" sheet metal screws.

- Secure each joint between sections of

chimney connector, including telescoping joints, with at least three sheet metal screws. The pre-drilled holes in the top of each section of chimney connector serve as guides when you drill 1/8" (3 mm) holes in the bottom of the next section.

- Secure the chimney connector to the chimney. Instructions for various installations follow.
- Be sure the installed stove and chimney connector are correct distances from nearby combustible material.

Note: Special slip pipes and thimble sleeves that form telescoping joints between sections of chimney connector are available to simplify installations. They often eliminate the need to cut individual connector sections. Consult your local dealer about these special pieces.

### Securing The Connector To A Prefabricated Chimney

Follow the installation instructions of the chimney manufacturer exactly as you install the chimney. The manufacturer of the chimney will supply the accessories to support the chimney, either from the roof of the house, at the ceiling of the room where the stove is installed, or from an exterior wall.

Special adaptors are available from your local dealer to make the connection between the prefabricated chimney

and the chimney connector. The top of such adaptors attach directly to the chimney or to the chimney's ceiling support package, while the bottom of the adaptor is screwed to the chimney connector.

These adaptors are designed so the top end will fit outside the inner wall of the chimney, and the bottom end will fit inside the first section of chimney connector. When assembled in this way, any soot or creosote falling from the inner walls of the chimney will stay inside the chimney connector.

### Securing The Connector To A Masonry Chimney

Both freestanding masonry chimneys and fireplace masonry chimneys may be used for installation of your Federal Convection Heater.

#### Freestanding Installations

If the chimney connector must pass through a combustible wall to reach the chimney, follow the recommendations in

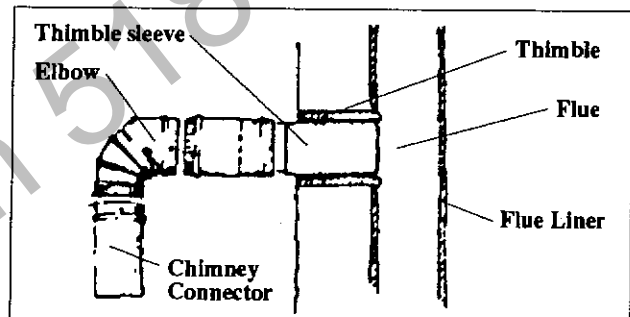

The thimble, made of either ceramic or metal, must be cemented in place securely.

the Wall Pass-Through section that follows.

The opening through the chimney wall to the flue (the "breach") must be lined with either a ceramic or metal cylinder, called the "thimble", which is securely cemented in place. Most chimney breeches incorporate thimbles, but check to be sure the fit is snug and the joint between thimble and chimney wall firmly cemented.

A special piece called the "thimble sleeve," slightly smaller in diameter than standard connector and most thimbles and, will facilitate the removal of the chimney connector system for inspection and cleaning. Thimble sleeves should be available from your local dealer.

To install a thimble sleeve, slide it into the breach until it is flush with the inner flue wall. Don't extend it into the actual flue passage, as this could interfere with the draft.

The thimble sleeve should protrude 1-2" (25-50 mm) into the room. Use furnace cement and thin gasketing to seal the sleeve in place in the thimble. Secure the chimney connector to the outer end of the sleeve with sheet metal screws.

Above A Fireplace

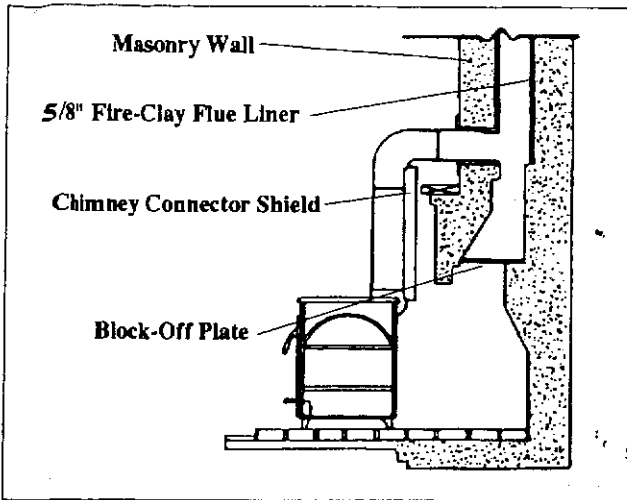

If the clearance between the chimney connector and either the mantel and the ceiling is inadequate in installations such as the one depicted here, it will require a special protective shield.

In this installation, the chimney connector rises from the stove, turns ninety degrees, and goes back into the fireplace chimney. The liner of the fireplace chimney should extend at least to the point at which the chimney connector enters the chimney. Follow all the guidelines for installing a chimney connector into a freestanding masonry chimney, and pay special attention to these additional points:

- If there is a combustible mantel or trim, check the stove and chimney connector clearances. Use the necessary combination of mantel, trim, and connector heat shields to provide the required clearances.
- Double-check connector clearance from the ceiling.
- The fireplace damper must be closed and sealed to prevent room air from being drawn up the flue, reducing the draft. However, it must be possible to re-open the damper to inspect or clean the chimney.

#### Through A Fireplace

A Federal Convection Heater may be installed through a

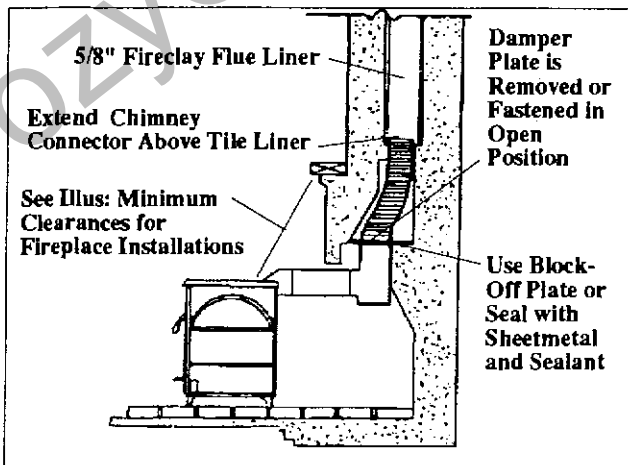

Special Fireplace Adaptor Kits to simplify fireplace installations are available from your local dealer.

fireplace in two different ways, depending on the safety regulations that apply to your situation, the height of the fireplace opening and your own preference: either without legs as a "Fireplace Insert," or with standard legs attached. For either situation, the chimney connector/positive connection kit goes back from the stove, enters the fireplace cavity, and turns upward. It then passes through the fireplace damper opening and smoke chamber and connects to the chimney flue.

A "positive connection" must be made in such installations to the chimney flue with a special kit available from your local dealer. Also, special clearance and floor protection provisions must be observed. These provisions are discussed in the Clearance and Floor Protection sections respectively.

#### Wall Pass-Throughs

Whenever possible, design your installation so the connector does not pass through a combustible wall. If you are considering a wall pass-through in your installation, check with your building inspector before you begin. Also check with the chimney connector manufacturer for any specific requirements.

Accessories are available for use as wall pass-throughs. If using one of these, make sure it has been tested and listed for use as a wall pass-through.

In the United States, the National Fire Protection Association (NFPA) has established guidelines for passing

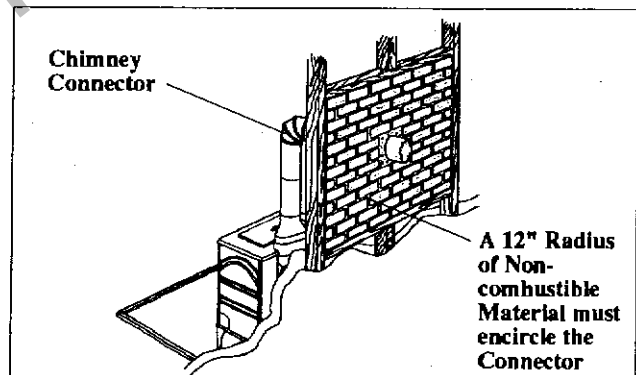

This is one recommended method of constructing a safe wall pass-through.

chimney connectors through combustible walls. Many building code inspectors follow these guidelines when approving installations.

The illustration below shows one NFPA-recommended method. All combustible material in the wall is cut away a sufficient distance from the single-wall connector to provide the required 12" clearance for the connector. Any material used to close up the opening must be non-combustible.

Three other methods are also approved by the NFPA. These are:

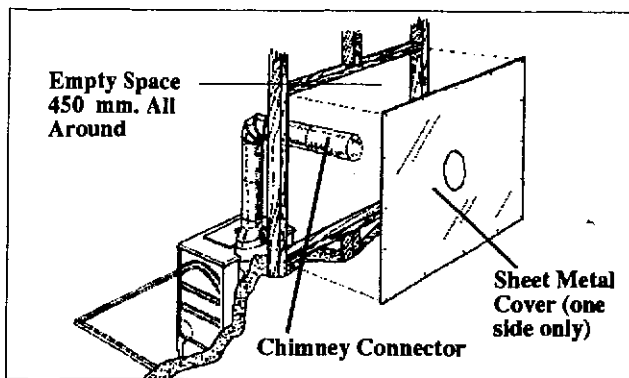

Another safe way of passing through combustible walls is this one approved by Canadian authorities.

- Using a section of double-wall chimney with a nine-inch clearance to combustibles.
- Placing a chimney connector pipe inside a ventilated thimble, which is then separated from combustibles by six inches of fiberglass insulating material.
- Placing a chimney connector pipe inside a section of eight-inch diameter, solid-insulated, factory-built chimney, with two inches of air space between the chimney section and combustibles.

In Canada, The Canadian Standards Association has established different guidelines. The illustration shows one method, in which all combustible material in the wall is cut away to provide the required 18" (450 mm) clearance for the connector. The resulting space must remain empty. A flush-mounted sheetmetal cover may be used on one side only. If covers must be used on both sides, each cover must be mounted on non-combustible spacers at least 1" (25 mm) clear of the wall. Your Consolidated Dutchwest dealer or your local building inspector can provide details of other approved methods of passing a chimney connector through a combustible wall. In Canada, this type of installation must conform to CAN/CSA-B365, Installation Code for Solid Fuel Burning Appliances and Equipment.

**NOTE:** Do not vent your Consolidated Dutchwest stove into a factory-built (zero-clearance) fireplace. These appliances and their chimneys are specifically designed as a unit for use as fireplaces. It may void the listing or be hazardous to adapt them for any other use.

**DO NOT CONNECT A FEDERAL CONVECTION HEATER TO ANY AIR DISTRIBUTION DUCT OR SYSTEM.**

## Floor Protection

### Freestanding Installations

In the United States, adding an optional Consolidated Dutchwest Bottom Heat Shield (part #1074 for FA224, #1075 for FA264, and #1076 for FA288) allows you to place the stove on a non-combustible floor protector that covers a combustible floor.

For U.S. installations, with the optional Consolidated Dutchwest bottom heat shield attached, a non-combustible floor protector such as 1/4" non-asbestos mineral board or equivalent, or 24 gauge sheet metal (that may be covered with a decorative non-combustible material if you desire) is required. The floor protector is required under the stove and must extend at least 16 inches from the front of the stove and from the left (loading door) side (labeled "A" in accompanying illustration), and at least 6 inches from the right side and rear ("B" in illustration). It must also extend under the chimney connector and 2 inches to either side.

Without the optional Consolidated Dutchwest Bottom Heat Shield, the only installations which are allowable require a completely non-combustible floor such as an unpainted concrete floor over earth.

In Canada, Consolidated Dutchwest Bottom Heat Shields are included as standard equipment and you may not operate a Federal Convection Heater without the shield in place. When installed on a combustible floor in Canada, a non-combustible floor protector is required under the heater. The floor protector must extend 18 inches (460 mm) to the front and left (loading door) side (labeled "A" in accompanying illustration), and 6 inches (150 mm) from the right side and rear ("B" in illustration). Do not obstruct the space under the heater.

If non-combustible material such as brick or ceramic tile is used without a non-combustible material under the hearth in either the United States or Canada, the spaces between the individual pieces must be filled with non-combustible mortar or grout to prevent sparks or embers from reaching the combustible floor underneath.

Model	U.S.	Canada
FA224	38" x 44"	40" x 48" (1020mm x 1220mm)
FA264	38" x 48"	40" x 60" (1020mm x 1520mm)
FA288	42" x 62"	42" x 62" (1070mm x 1580mm)

Minimum Dimensions For Non-Combustible Floor Protectors (Depth X Width)

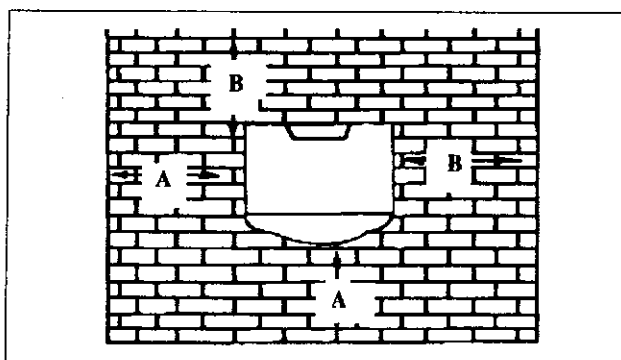

Be sure to follow exactly the floor protection requirements on all four sides of the stove.

You will notice that these floor protector requirements call for more protection on the left side than on the right. If you wish a more balanced look, achieve it by adding to the hearth. Do not reduce any side protection under any circumstances.



## Fireplace Installations

There are two ways that you may install your Federal Convection Heater in an existing fireplace: as a fireplace insert with no legs, or with the standard legs attached.

In order to install the heater without legs as a fireplace insert, or with the standard legs attached but without the Consolidated Dutchwest bottom heat shield (in the United States only), the floor must be completely non-combustible, such as an unpainted concrete floor over earth. Remember, in Canada the stove may not be used without the bottom heat shield attached.

Many fireplaces do not satisfy the "completely non-combustible" requirement because the brick or concrete hearth in front of the fireplace opening usually is supported by heavy wooden framing. Because neither brick nor concrete is a good insulator, heat radiated onto the hearth under the stove will be transferred through to the wooden framing. As a result, such fireplace hearths are considered a combustible floor. You may not install a heater on them without legs as a fireplace insert, and standard leg installations must include the bottom heat shield. The floor protector must meet requirements as well.

### Floor Protection for Fireplace Installations with Standard Legs Attached

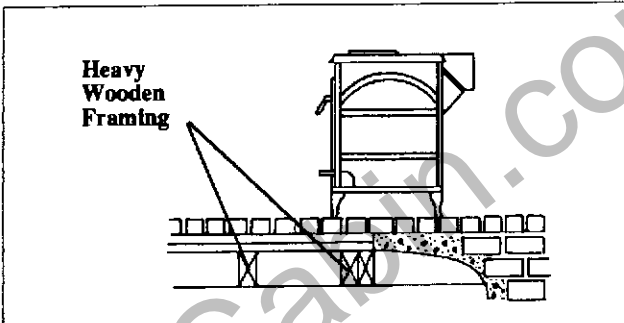

Combustible supporting timbers may lie beneath fireplace hearths; such situations require additional floor protection.

In the United States, fireplace installations with the standard legs and the bottom heat shield attached must have a floor protector of the same construction as that specified for freestanding installations: 1/4" non-asbestos mineral board or equivalent, or 24 gauge sheet metal (that may be covered with a decorative non-combustible material if you desire). The floor protector must extend at least 16" from the front of the stove and from the left (loading door) side, and at least 6" from the right side and rear. It must also provide protection beneath any horizontal runs of the chimney connector, including 2" to either side.

In Canada, the non-combustible floor protector must extend 18" (450 mm) from the front of the stove and from the left (loading door) side, and 6" (150 mm) from the right side and rear of stove.

Many raised hearths will extend less than 18 inches (450 mm) from the front of the heater when it is installed. In such cases, sufficient floor protection as described above must be added in front of the hearth to satisfy the minimum floor protector requirement from the front of the stove: 16" from the front in the United States and 18" from the front in Canada.

Hearth rugs do not satisfy the requirements for floor protection.

Fireplace insert installations also have special clearance requirements to the side walls, side decorative trim, and fireplace mantle. This information is found in the Clearance section on page 16.

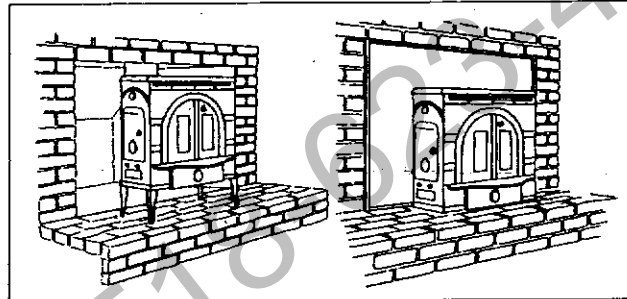

Extra floor protection may be required for the fireplace hearth, even if your stove is installed with the legs and the bottom heat shield; **FIREPLACE INSERT INSTALLATIONS WITHOUT LEGS ARE ALLOWED ONLY IF THE HEARTH IS COMPLETELY NON-COMBUSTIBLE, SUCH AS UNPAINTED CONCRETE OVER EARTH.**

### Keep The Stove A Safe Distance From Surrounding Materials

Both a stove and its chimney connector radiate heat in all directions when operating. A safe installation requires that adequate clearance be maintained between the stove and nearby combustible materials to ensure that such materials do not overheat.

Clearance is the distance between either your stove or chimney connector, and nearby walls, floors, the ceiling, and any other fixed combustible surface. Keep furnishings and other combustible materials away from the stove as well. In general, a distance of 48" (1220 mm) must be maintained between the stove and moveable combustible items such as drying clothes, furniture, newspapers, firewood, etc. Keeping those clearance areas empty assures that nearby surfaces and objects will not overheat.

### Safe Ways To Reduce Clearances

Your stove has special clearance requirements that have been established after careful research, and testing to UL and ULC standards.

Clearance requirements have been established to meet

every installation possibility, and they involve the combination of four basic variables:

- When the stove *has no* listed heat shield mounted on it.
- When the stove *has a* listed heat shield mounted on it.
- When the wall *has no* listed heat shield mounted on it.
- When the wall *has a* listed heat shield mounted on it.

In general, the greatest clearance is required when you are placing a stove with no heat shield near a wall with no heat shield. The least clearance is required when both the stove and the wall have heat shields. Reducing a stove clearance may require a listed heat shield on the chimney connector as well.

Clearances may be reduced only by means approved by the regulatory authority, and in accordance with the clearances listed in this manual. The charts and sample installations that follow list all the clearances required for the various installation configurations of Federal Convection Heaters FA224, FA264, and FA288.

### Fireplace Installations

A fireplace installation requires special clearance between the:

- Side of the stove and the right and left walls
- Side of the stove and the decorative side trim on the fireplace face
- Top of the stove and the mantel

In addition, both Fireplace Adaptor and Fireplace Insert installations have special floor protection requirements that are addressed in the section on Floor Protection.

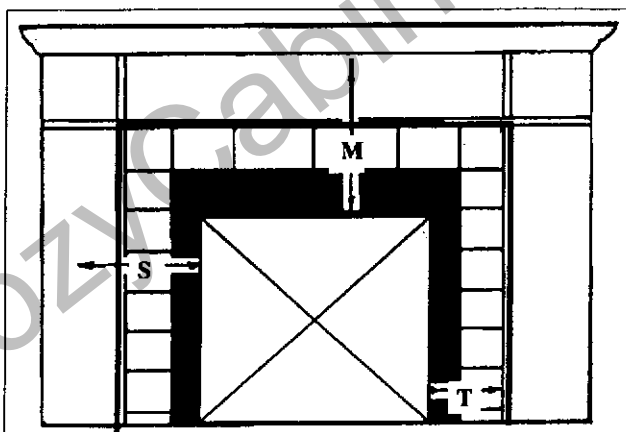

	FA224	FA226	FA288
Side walls (S)	20"(510 mm)	24"(610 mm)	23"(580 mm)
Trim (T)	12"(300 mm)	12"(300 mm)	12"(300 mm)
Mantel (M)	20"(510 mm)	20"(510 mm)	20"(510 mm)

#### Minimum Clearances for Fireplace Installations.

Recommended clearances must be maintained between a stove and the surrounding combustible components.

### Designing A Safe Installation

The pages that follow contain charts with the information that you'll need to make your installation safe. The chart on the facing page tells you exactly where to cut the hole in the ceiling so that the stove will meet clearance requirements. Pages 20-21 give the stove clearances for all installations, and pages 23-25 illustrate the required sizes of wall shield to provide the needed protection.

Refer to these charts regularly as you plan the installation and do not compromise on any of the figures listed.

# Distance from Center of Flue Collar to Wall in Top-Exit Installations

**NOTE:** To locate the center of the flue collar for corner installations, add 7" (180 mm) to the clearance distance from stove corner to wall. Mark off the resulting distance from the corner along both walls. Next, measure the same distance from these two points out from the walls. These last two measurements will meet at a point representing the center of the flue collar. Refer to the diagrams below.

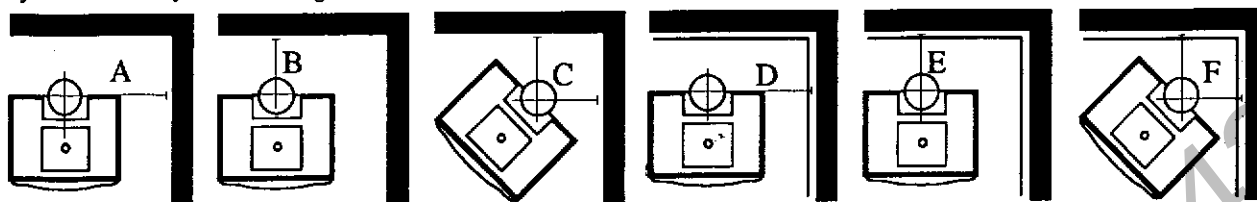

**FA224: WITH Stove and Chimney Connector Heat Shields**

Unprotected Surfaces			Protected Surfaces		
Parallel Installations		Corners	Parallel Installations		Corners
Side (A)	Rear (B)	Corner (C)	Side (D)	Rear (E)	Corner (F)
31" (790mm)	17" (430mm)	29-7/8" (760mm)	21" (530mm)	9" (230mm)	14-7/8" (380mm)

**FA224: WITHOUT Stove and Chimney Connector Heat Shields**

Unprotected Surfaces			Protected Surfaces		
Parallel Installations		Corners	Parallel Installations		Corners
Side (A)	Rear (B)	Corner (C)	Side (D)	Rear (E)	Corner (F)
31" (790mm)	30" (760mm)	31-7/8" (760mm)	21" (530mm)	14" (360mm)	18-7/8" (480mm)

**FA264: WITH Stove and Chimney Connector Heat Shields**

Unprotected Surfaces			Protected Surfaces		
Parallel Installations		Corners	Parallel Installations		Corners
Side (A)	Rear (B)	Corner (C)	Side (D)	Rear (E)	Corner (F)
37" (940mm)	13-3/4" (350mm)	27-1/4" (690mm)	25" (640mm)	11" (280mm)	18-1/4" (690mm)

**FA264: WITHOUT Stove and Chimney Connector Heat Shields**

Unprotected Surfaces			Protected Surfaces		
Parallel Installations		Corners	Parallel Installations		Corners
Side (A)	Rear (B)	Corner (C)	Side (D)	Rear (E)	Corner (F)
37" (940mm)	29" (740mm)	32-1/4" (820mm)	25" (640mm)	13-3/4" (350mm)	20-1/4" (520mm)

**FA288: WITH Stove and Chimney Connector Heat Shields**

Unprotected Surfaces			Protected Surfaces		
Parallel Installations		Corners	Parallel Installations		Corners
Side (A)	Rear (B)	Corner (C)	Side (D)	Rear (E)	Corner (F)
37-1/4" (690mm)	16-3/4" (425mm)	28-1/4" (720mm)	32-1/4" (820mm)	11" (280mm)	24-1/4" (620mm)

**FA288: WITHOUT Stove and Chimney Connector Heat Shields**

Unprotected Surfaces			Protected Surfaces		
Parallel Installations		Corners	Parallel Installations		Corners
Side (A)	Rear (B)	Corner (C)	Side (D)	Rear (E)	Corner (F)
37-1/4" (690mm)	27-3/4" (705mm)	32-1/4" (820mm)	32-1/4" (820mm)	16-3/4" (425mm)	24-1/4" (620mm)

# Stove Clearance Charts

FA224	UNPROTECTED SURFACES			PROTECTED SURFACES		
	Parallel Installations		Corner Installations	Parallel Installations		Corner Installations
Stove Clearance	Side	Rear	Corner	Side	Rear	Corner
No heat shields	[A] 20" (510 mm)	[B] 31" (790 mm)	[C] 25" (640 mm)	[D] 10" (250 mm)	[E] 15" (380 mm)	[F] 12" (300 mm)
Rear exit, rear h.s. only	[G] 20" (510 mm)	[H] 18" (450 mm)	NA	[I] 10" (250 mm)	[J] 10" (250 mm)	NA
Top exit, rear & connector shields (1, 2)	[K] 20" (510 mm)	[L] 18" (450 mm)	[M] 16" (410 mm)	[N] 10" (250 mm)	[O] 10" (250 mm)	[P] 8" (200 mm)
Chimney Connector Clearance	All Installations			All Installations		
No heat shields	27" (690 mm)			11" (280 mm)		
Connector heat shields (2)	14" (360 mm)			6" (150 mm)		
Front Clearance to Combustibles	All Installations					
	48" (1220 mm)					

FA264	UNPROTECTED SURFACES			PROTECTED SURFACES		
	Parallel Installations		Corner Installations	Parallel Installations		Corner Installations
Stove Clearance	Side	Rear	Corner	Side	Rear	Corner
No heat shields	[A] 24" (610 mm)	[B] 30" (760 mm)	[C] 24" (610 mm)	[D] 12" (300 mm)	[E] 15" (380 mm)	[F] 12" (300 mm)
Rear exit, rear h.s. only	[G] 24" (610 mm)	[H] 15" (380 mm)	NA	[I] 12" (300 mm)	[J] 12" (300 mm)	NA
Top exit, rear & connector shields (1, 2)	[K] 24" (610 mm)	[L] 15" (380 mm)	[M] 19" (480 mm)	[N] 12" (300 mm)	[O] 12" (300 mm)	[P] 10" (250 mm)
Chimney Connector Clearance	All Installations			All Installations		
No heat shields	26" (690 mm)			11" (280 mm)		
Connector heat shields (2)	11" (360 mm)			8" (150 mm)		
Front Clearance to Combustibles	All Installations					
	48" (1220 mm)					

FA288	UNPROTECTED SURFACES			PROTECTED SURFACES		
	Parallel Installations		Corner Installations	Parallel Installations		Corner Installations
Stove Clearance	Side	Rear	Corner	Side	Rear	Corner
No heat shields	[A] 23" (580 mm)	[B] 29" (740 mm)	[C] 23" (580 mm)	[D] 18" (450 mm)	[E] 18" (450 mm)	[F] 19" (480 mm)
Rear exit, rear h.s. only	[G] 23" (580 mm)	[H] 18" (450 mm)	NA	[I] 18" (450 mm)	[J] 12" (300 mm)	NA
Top exit, rear & connector shields (1, 2)	[K] 23" (580 mm)	[L] 18" (450 mm)	[M] 19" (480 mm)	[N] 18" (450 mm)	[O] 12" (300 mm)	[P] 15" (380 mm)
Chimney Connector Clearance	All Installations			All Installations		
No heat shields	24" (610 mm)			13" (330 mm)		
Connector heat shields (2)	13" (330 mm)			7" (180 mm)		
Front Clearance to Combustibles	All Installations					
	48" (1220 mm)					

- 1—Shielding for a top exit stove must include a shield insert to protect the area behind the flue collar.
- 2—Chimney connector heat shields are required when using rear heat shield and must extend exactly 28" (710 mm) above the flue collar of the stove.
- 3—All installations venting straight up to a factory built chimney require a 24"(610 mm) diameter or square ceiling heat shield. The ceiling heat shield should be 24 gauge sheet metal or equivalent mounted on 1" (25 mm) non-combustible spacers 1" (25 mm) below ceiling.
- 4—Chimney connector heat shields must extend to within 1" (25 mm) or less of the ceiling heat shield for installations venting straight up to a factory-built chimney. Top exit installations using an elbow to vent to rear chimney connector must be shielded over entire vertical length.

# Stove Clearance Diagrams

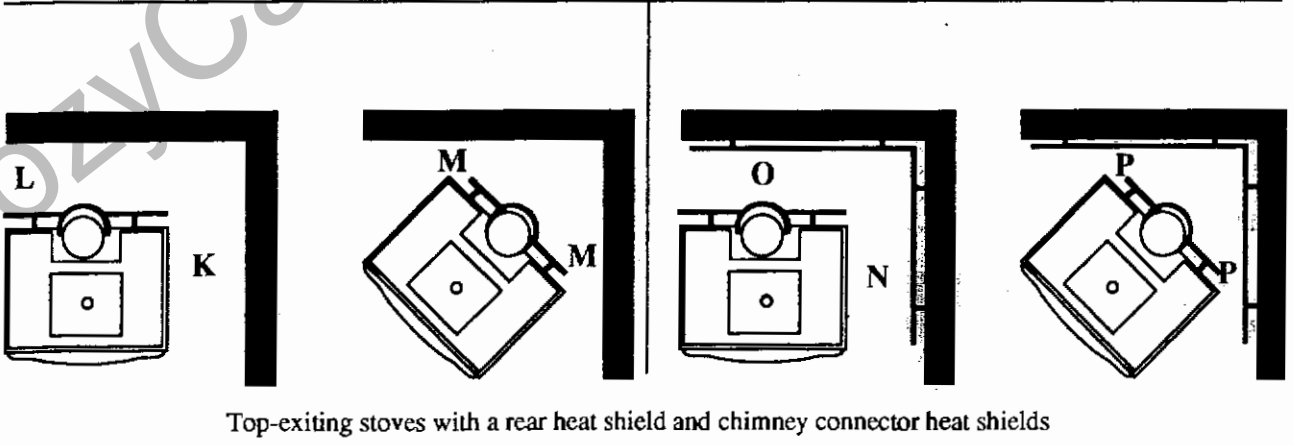
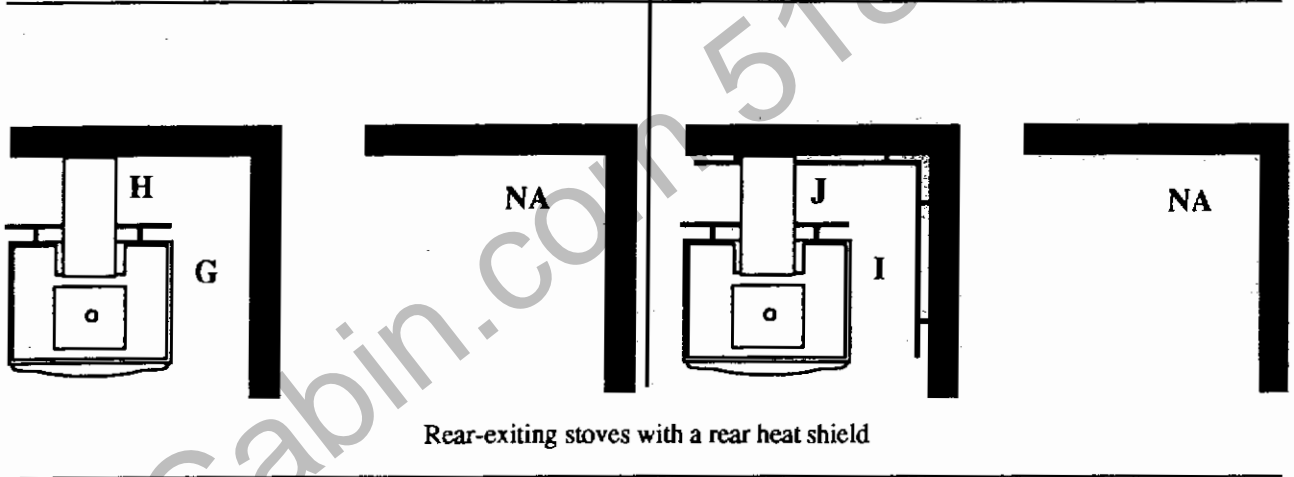
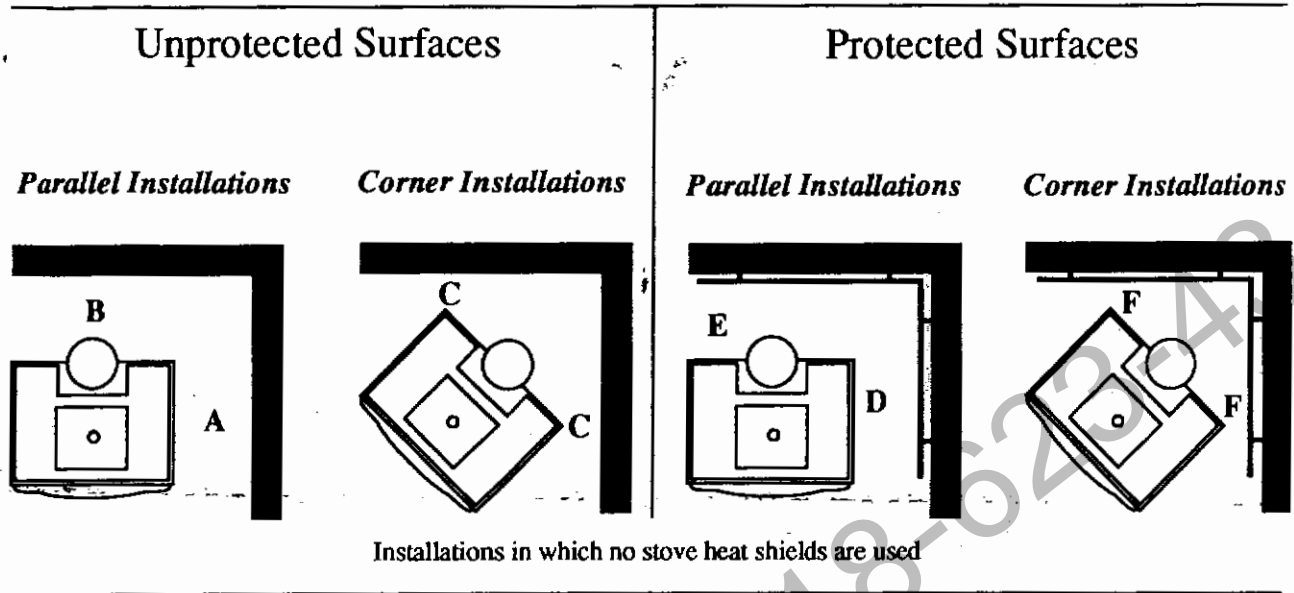

# Wall Heat Shield Dimensions: FA224

 The shaded area is not required for rear exit installations vented directly into the chimney.

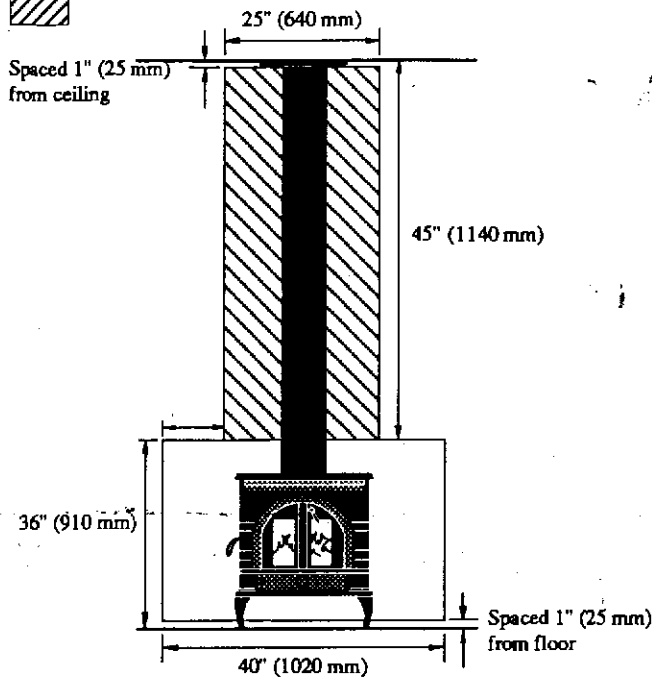

Rear Wall Protection

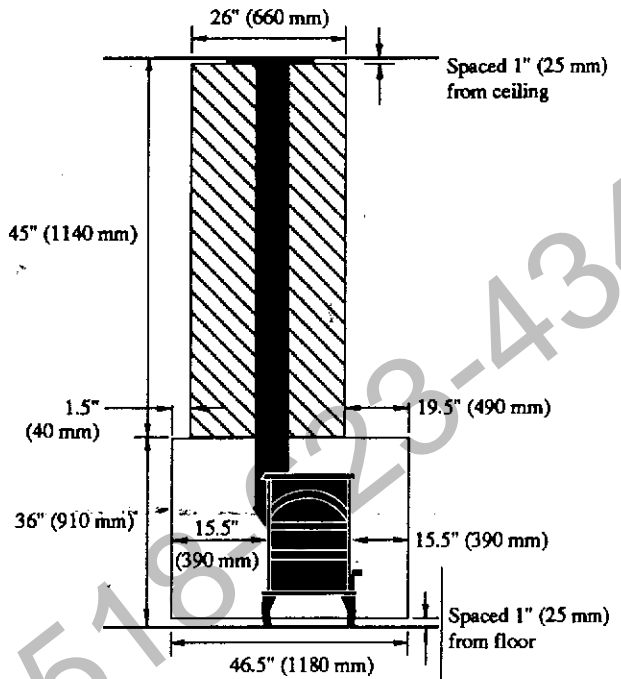

Side Wall Protection

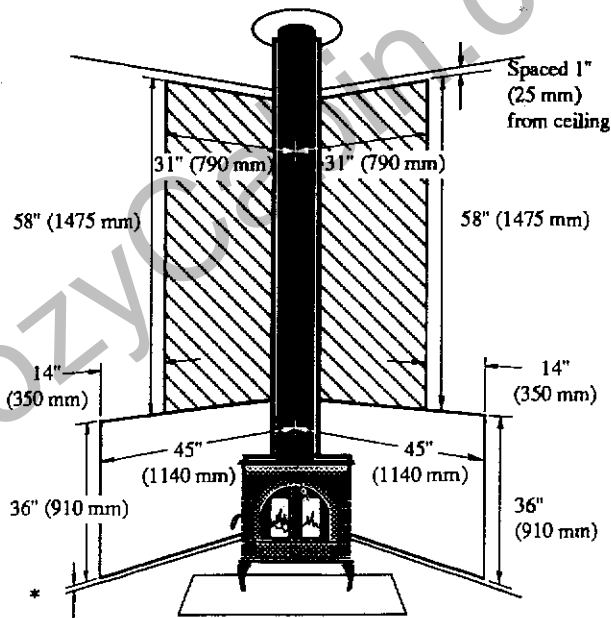

\* Spaced 1" (25 mm) from floor

Wall Protection, 8" Corner

Rear corners of stove 8" (200 mm) from the wall; rear and chimney connector heat shields attached to stove; wall shields meet at corner

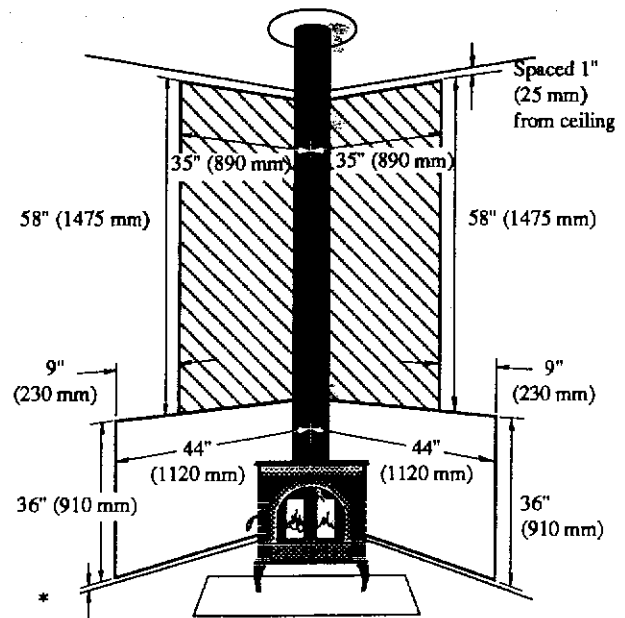

\* Spaced 1" (25 mm) from floor

Wall Protection, 10" Corner

Rear corners of stove 10" (250 mm) from the wall; no rear or chimney connector heat shields attached to stove; wall shields meet at corner

# Wall Heat Shield Dimensions: FA264

 The shaded area is not required for rear exit installations vented directly into the chimney.

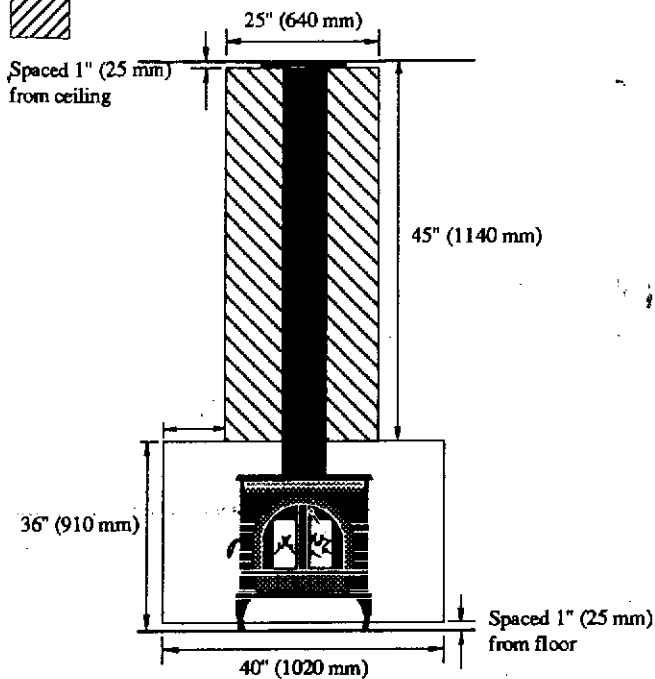

Rear Wall Protection

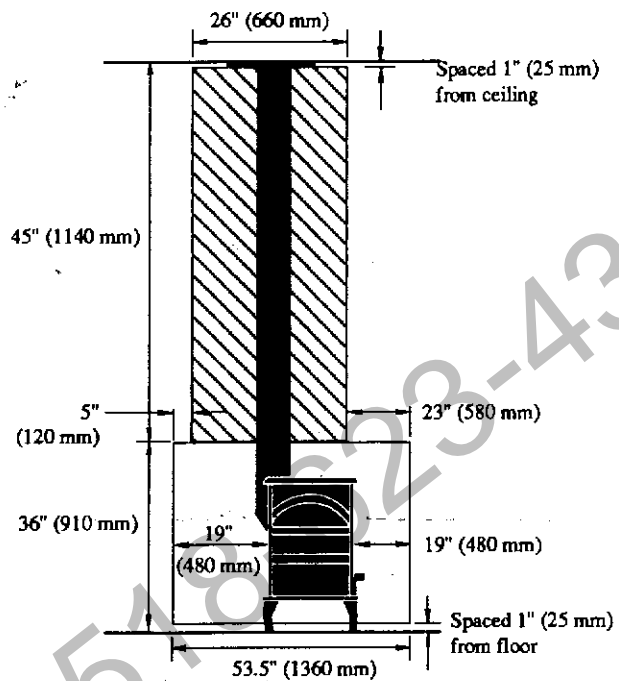

Side Wall Protection

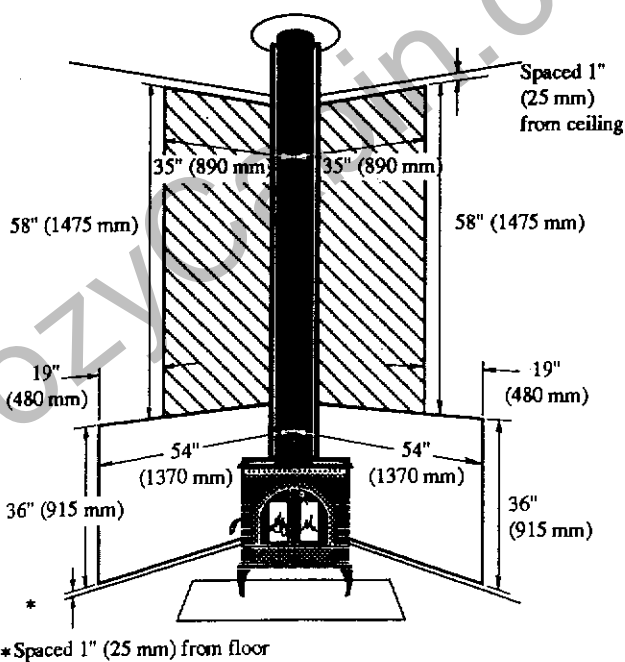

Wall Protection, 10" Corner

Rear corners of stove 10" (250 mm) from the wall; rear and chimney connector heat shields attached to stove; wall shields meet at corner

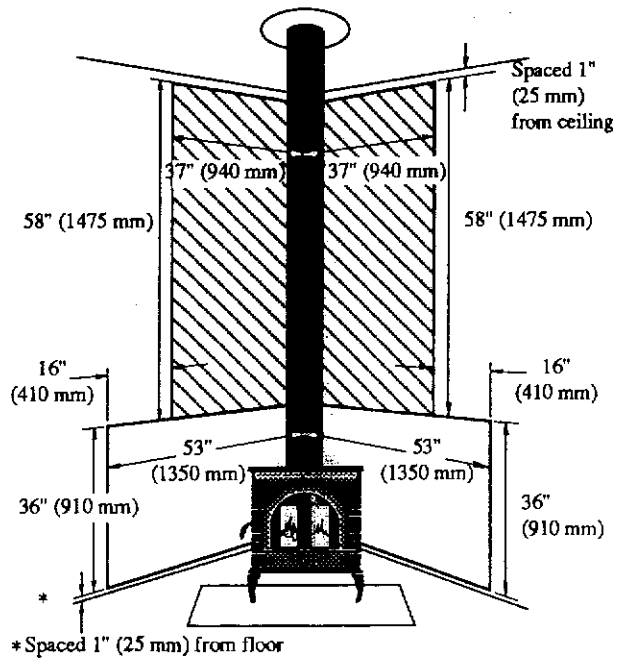

Wall Protection, 12" Corner

Rear corners of stove 12" (300 mm) from the wall; no rear or chimney connector heat shields attached to stove; wall shields meet at corner

# Wall Heat Shield Dimensions: FA288



The shaded area is not required for rear exit installations vented directly into the chimney.

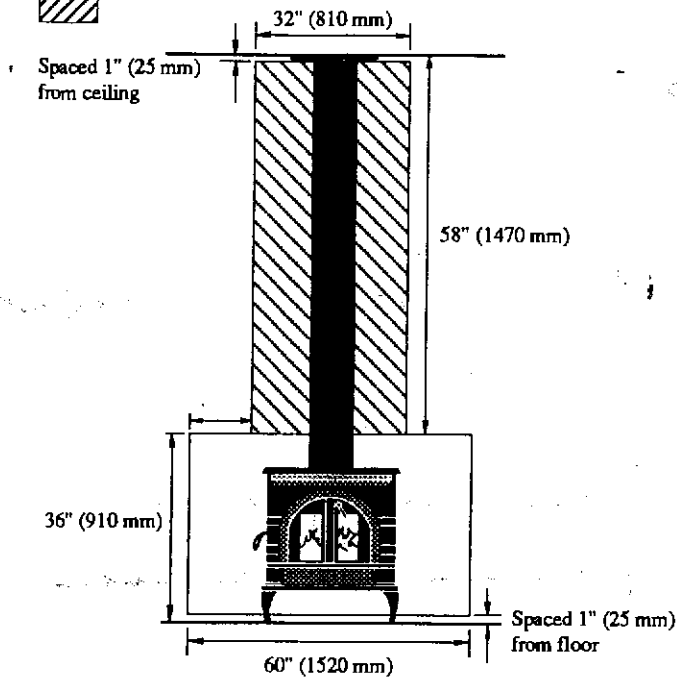

Rear Wall Protection

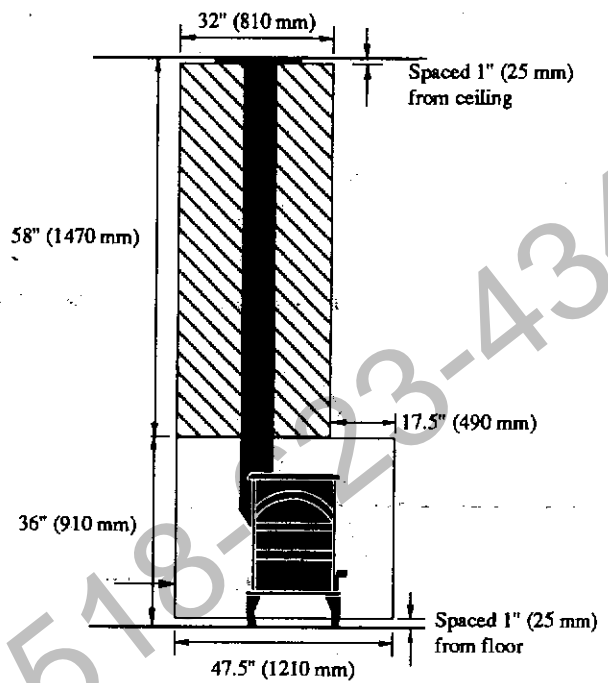

Side Wall Protection

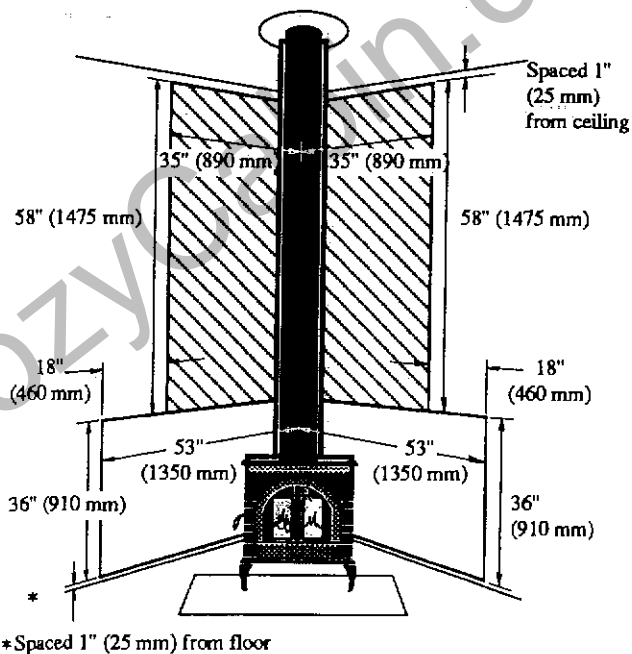

Wall Protection, 15" Corner

Rear corners of stove 15" (380 mm) from the wall; rear and chimney connector heat shields attached to stove; wall shields meet at corner



# Specifications

Specifications include dimensions for planning purposes only. Before beginning your installation, consult your local dealer for final specifications.

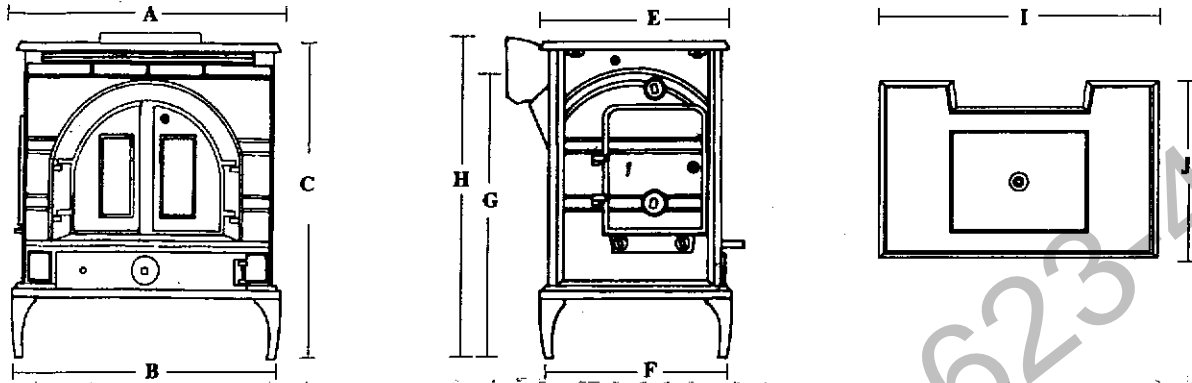

Stove Model Number	FA224	FA 264	FA 288
A	22" (560 mm)	26" (660 mm)	28" (710 mm)
B	21" (530 mm)	24.5" (620 mm)	27" (690 mm)
C	29.75" (750 mm)	29.75" (750 mm)	31.75" (830 mm)
D	16" (410 mm)	16" (410 mm)	33" (840 mm)
E	15.5" (390 mm)	15.5" (390 mm)	17.5" (440 mm)
F	26.75" (690 mm)	27" (690 mm)	30" (760 mm)
G	30" (760 mm)	30" (760 mm)	30" (760 mm)
H	22" (560 mm)	26" (660 mm)	28" (710 mm)
I	16" (410 mm)	16" (410 mm)	33" (840 mm)
Log length:	19" (480 mm)	22" (560 mm)	25" (640 mm)
Maximum burn time:*	8 hrs.	10 hrs.	12 hrs.
Average area heated (ft. <sup>2</sup> ):**	700-1,400 (65-130 m <sup>2</sup> )	800-1,600 (75-150m <sup>2</sup> )	1,200-2,400 (112-224 m <sup>2</sup> )
Range of heat output:***	9,100-34,800 Btu's/hr.	9,500-31,700 Btu's/hr.	7,800-29,300 Btu's/hr.
Maximum heat output:****	35,000 Btu's/hr.	40,000 Btu's/hr.	55,000 Btu's/hr.
Weight:	380 lbs. (172 kg)	436 lbs. (198 kg)	634 lbs. (288 kg)
Loading:	Side or front	Side or front	Side or front
Flue exit position (reversible):	Top or rear	Top or rear	Top or rear
Air control:	3 controls	3 controls	3 controls

# Parts List and General Exploded View

**Part # Part Name (Refers to all three Federal Convection models.)**

- 1 Bottom
- 2 Back
- 3 Bottom, inner
- 4 Back, inner
- 5 Top, inner
- 6 Channel cap, inner
- 7 Air distributor
- 8 Baffle
- 9 Interam gasket
- 10 Catalytic combustor
- 11 Side, right
- 12 Side, left
- 13 Door, side
- 14 Door latch
- 15 Door shaft
- 16 Set screw, 5/16-18 x 5/16"
- 17 Front
- 18 Door, right front
- 19 Panel, door
- 20 Door, left front
- 21 Ashdoor
- 22 Rocker grate
- 23 Grate cover
- 24 Cap, shaker
- 25 Fixed grate
- 26 Grate frame
- 27 Fan plate
- 28 Damper
- 29 Damper adjuster
- 31 Hex head bolt 1/4-20 x 1"
- 32 Washer,
- 33 Hex nut 1/4-20
- 34 Tab, damper
- 35 Damper crank
- 36 Damper operating rod
- 37 Grate back
- 38 Air plate, balance
- 39 Top
- 40 Hearth
- 41 Flue collar
- 42 Leg
- 47 Firescreen
- 48 Brass handle
- 49 Handle extension
- 50 Brass dial damper, small
- 51 Brass dial damper, large
- 52 Name plate
- 53 Shaker tool
- 55 Ash pan
- 56 Refractory package
- 57 Handle spring
- 60 Rod, front

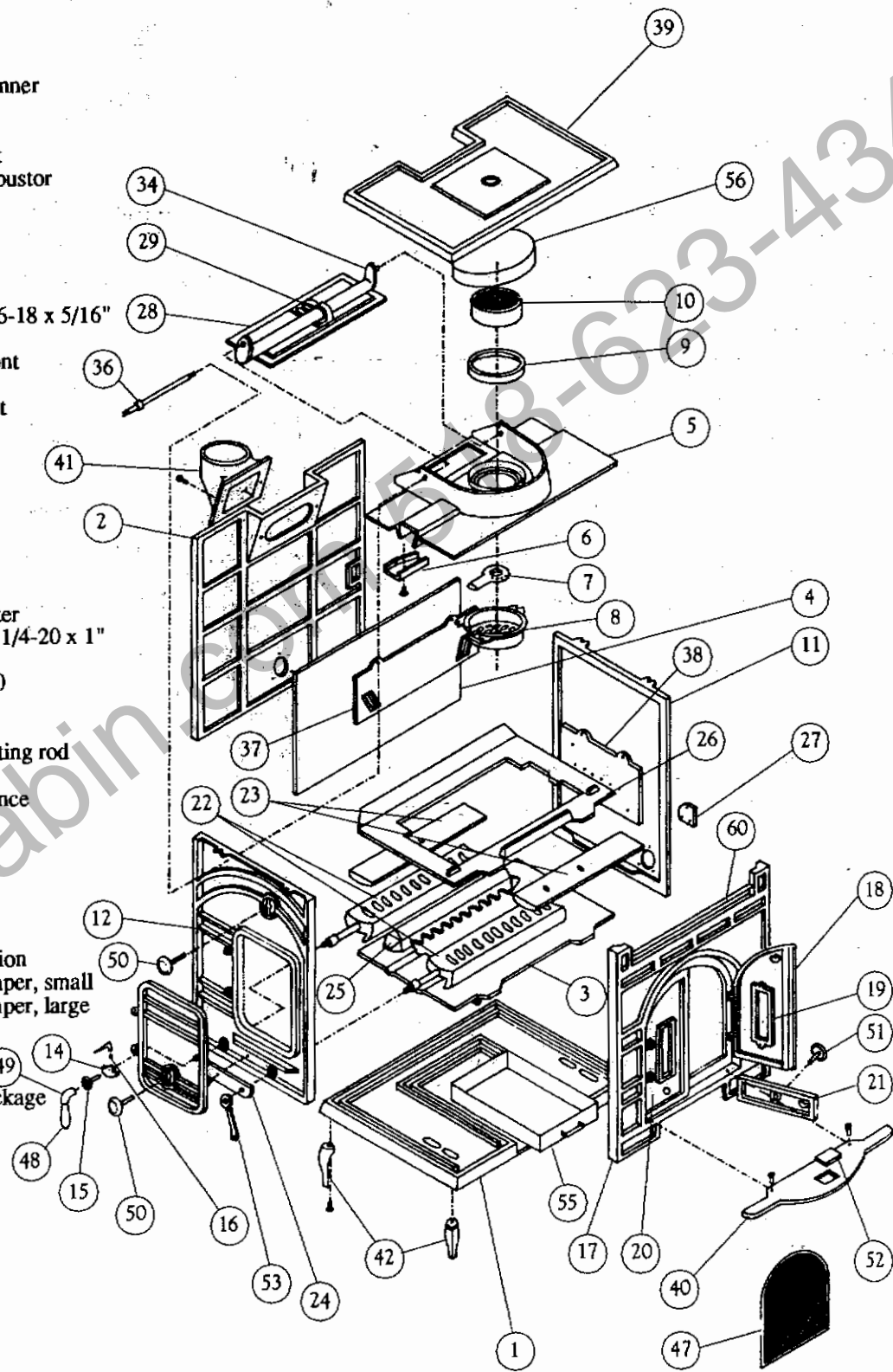

# Appendix

## Catalytic Combustor

In any chemical reaction, including the combustion process, there are certain conditions which must be met before the reaction can take place. For example, a reaction may require a certain temperature, or a certain concentration of the reactants (the combustion gases and oxygen), or a certain amount of time. Catalysts, though not changed themselves during the reaction, have the ability to act at a molecular level to change these requirements. In the secondary combustion chamber of the Federal Convection Heaters, the catalyst reduces the temperature at which secondary combustion can start from the 1000° F. - 1200° F. (540 C - 650 C) range to the 500° F. - 600° F. (260 C - 315 C) range, increasing efficiency, and reducing creosote and emissions.

The catalytic reaction, though advantageous, does have some limitations of its own. Primary among these is that the reactants (the gases) come into close physical contact with the catalyst itself.

To ensure the necessary contact, the catalytic element in your Federal Convection Heater is composed of a ceramic base in the shape of a honeycomb. On each of the honeycomb's many surfaces a coating of the catalyst (usually a noble metal such as platinum or palladium) is applied. The large surface area exposed in this configuration ensures that the combustion gases have the greatest opportunity to come in contact with the catalyst.

Loss of catalytic activity will be apparent in several ways. First you may notice an increase in fuel consumption. Second, there will be a visible increase in the rate at which creosote builds up in your chimney connector system. You may also notice a heavy discharge of smoke from the chimney. There are a number of catalytic problems which can cause loss of activity:

### **Blockage**

While the honeycomb pattern ensures good contact, it also increases the resistance to flow of the combustion gases, and, because of the many surfaces, provides more places for creosote and fly ash to deposit. It is important to follow the operating instructions in order to minimize these deposits, and to periodically inspect your catalyst for signs of blockage.

### **Masking and Poisoning**

While the catalyst itself does not enter into the combustion process, it is possible for certain elements, such as lead and sulfur, to attach to the active sites on the surface of the honeycomb. Though the catalyst is still there, it is covered, or masked, by the contaminant, and cannot function. To avoid this situation, it is important not to burn anything in your Federal Convection Heater that is a source of these contaminants. Particularly avoid painted or treated wood, coal, household trash, colored papers, metal foils, or plastics. Chemical chimney cleaners may also contain harmful elements. The safest approach is to burn only untreated, natural wood.

### **Flame Impingement**

The catalytic element is not designed for exposure to direct flame. If you continually overfire your Federal Convection Heater the chemistry of the catalyst coating may be altered, inhibiting the combustion process.

Thermal degradation of the ceramic base may also occur, causing the element to disintegrate. Stay within the recommended guidelines of the Operation section.

### **Mechanical Damage**

If the element is mishandled, damage may occur. Always treat the element carefully. Remember the catalyst is made of a ceramic material; treat it as you would fine china. Hairline cracks will not affect the performance of the catalyst, as long as the steel sleeve holds the element in the proper position.

### **Peeling**

Peeling of the surface coat may occur if the catalytic element is frequently subjected to excessive temperatures. Follow the operating instructions carefully to avoid this type of damage.

Every Consolidated Dutchwest product is equipped with either a Corning "Long-Life"® or a Technical Glass Products "Honeycomb"®. The products are equivalent. If for any reason you must ship your catalytic element, remember its fragile nature. Place the element in a plastic bag, and package it with a generous amount of shock absorbing material.

# Consolidated Dutchwest Warranty

## Limited Three Year Warranty

Consolidated Dutchwest warrants that your stove will be free of defects in materials and workmanship for a period of three years from the date received except the grates, handles, and gaskets, which have no warranty. The catalyst, cement, glass, and fans are subject to normal wear and tear and are warranted as described below.

Consolidated Dutchwest will repair or replace, at its option, any part found to be defective when the stove is returned with shipping charges prepaid to an authorized Vermont Castings dealer. The customer must pay for any authorized dealer in-home travel fees, service charges, or transportation costs for returning the stove to the authorized dealer. If upon inspection the defect is found to be the fault of the manufacturer, repairs will be authorized at no charge to the customer for parts and/or labor.

This warranty covers only the original purchaser and is not transferable.

## Limited One Year Warranty

The following parts are warranted to be free of defects in material and workmanship for a period of one year from the date you receive your stove. These parts are the glass door panels, fans, and cement. Any of these items found to be defective will be repaired or replaced at no charge upon return of said part to an authorized Vermont Casting dealer with postage prepaid.

## Catalyst Warranty

The catalyst will be warranted for a six year period as follows: If the original catalyst or a replacement catalyst proves defective or ceases to maintain 70% of its particulate emission reduction activity (as measured by an approved testing procedure) within 24 months from the date the Federal Convection Heater is received, the catalyst itself will be replaced free. For stove purchases made after June 30, 1990, a third year (25-36 months) of no charge replacement will be made when combustor failure is due to thermal degradation of the substrate (crumbling of ceramic material). From 25-72 months a pro-rated credit will be allowed against a replacement catalyst and the cost of labor necessary for replacement at the time of replacement. The customer must pay for any in-home travel fees, service charges, or transportation costs for returning the Federal Convection Heater to the authorized dealer.

Any replacement catalyst will be warranted under the terms of the catalyst warranty for the remaining term of the original warranty. The purchaser must provide the following information in order to receive a replacement catalyst under the terms of this limited warranty:

1. Name, address, and telephone number.
2. Proof of original purchase date.
3. Date of failure of catalyst.
4. Any relevant information or circumstances regarding determination of failure.
5. In addition, the owner must return the failed catalyst.

## Grates

All grates are not covered by this warranty. The grates include the front grate, side grates, grate back, grate frame, grate caps, rocker grates, and fixed grates.

## Exclusions

This warranty is not applicable to products which have been altered or repaired outside of the warrantor's facilities or subjected to misuse, abuse, neglect, accident, or damage by improper installation or application. Further, this warranty shall not apply, and Consolidated Dutchwest shall have no further obligations with respect to any stove which has not been installed, inspected, operated, and maintained in accordance with all applicable local codes and regulations and in accordance with the warrantor's printed instructions and any plates attached to the stove body or parts. Warrantor shall not be responsible for defects or consequential damages resulting from unauthorized use or repair by anyone other than the warrantor or representatives of the warrantor.

## Purchaser's Responsibility

The purchaser must be able to give proof of purchase. In addition to filling out the warranty registration card be sure to keep a copy of your sales invoice.

## Limitations Of Implied Warranties And Damages

This warranty is in lieu of all other warranties. Implied warranties of merchantability and fitness are specifically excluded unless state law does not authorize such exclusion. In no event shall the warrantor be liable for any contingent, incidental, or consequential damage or expense due to partial or complete inoperability of the product, illegal use of the product, or for any other reason whatsoever unless state law does not authorize such limitation for such reason or reasons. Check with local officials to see specifically what rights you have in your state.



A Division of V.C.I.  
Route 107 • P.O. Box 501  
Bethel, Vermont 05032

Patents: US - D288357, 4502395, 4646712;  
Canada - 1235969. Other foreign mechanical  
patents issued.

©September, 1992 Vermont Castings, Inc. All  
rights reserved. Prices and specifications subject  
to change without notice.

Printed in the U.S.A. #700-1030C