

CDVSC7 Series CDV7 Series Direct Vent Gas Fireplace

Models:
 CDVR33N/PV7;N/PV117;N/PE7;N/PSC117,
 CDVT33N/PV7;N/PE7;N/PSC7,
 CDVR36N/PV7;N/PE7;N/PSC7,
 CDVT36N/PV7;N/PE7;N/PSC7,
 CDVR42NPV7;NPE7;N/PSC7,
 CDVT42N/PV7;N/PE7;N/PSC7,
 CDVR47N/PV7;N/PE7;N/PSC7,
 CDVT47N/PV7;N/PE7;N/PSC7

Installation and Operating Instructions

WARNINGS

IF THE INFORMATION IN THESE INSTRUCTIONS ARE NOT FOLLOWED EXACTLY, A FIRE OR EXPLOSION MAY RESULT CAUSING PROPERTY DAMAGE, PERSONAL INJURY OR LOSS OF LIFE.

- Do not store or use gasoline or other flammable vapors and liquids in the vicinity of this or any other appliance.
- **WHAT TO DO IF YOU SMELL GAS**
 - Do not try to light any appliance.
 - Do not touch any electrical switch; do not use any phone in your building.
 - Immediately call your gas supplier from a neighbor's phone. Follow the gas supplier's instructions.
 - If you cannot reach your gas supplier, call the fire department.
- Installation and service must be performed by a qualified installer, service agency or the gas supplier.

WARNING: Improper installation, adjustment, alteration, services or maintenance can cause injury or property damage. Refer to this manual. For assistance or additional information consult a qualified installer, service agency or the gas supplier.

This appliance may be installed in an aftermarket*, permanently located, manufactured home (USA only) or mobile home, where not prohibited by local codes.

This appliance is only for use with the type of gas indicated on the rating plate. This appliance is not convertible for use with other gases, unless a certified kit is used.

* Aftermarket: Completion of sale, not for purpose of resale, from the manufacturer.

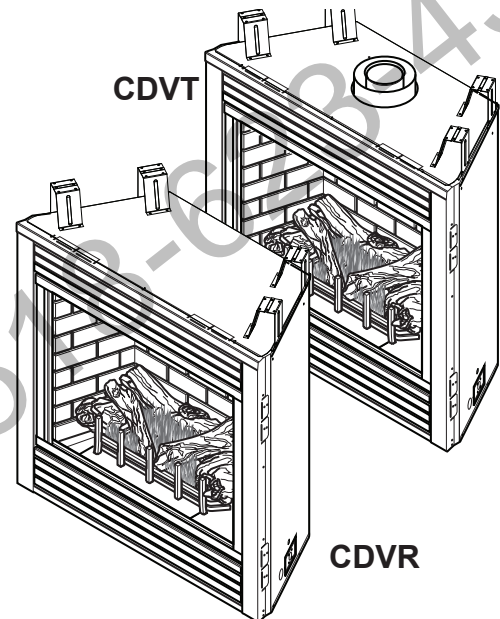

WARNING



**HOT GLASS WILL
CAUSE BURNS.**

**DO NOT TOUCH GLASS
UNTIL COOLED.**

**NEVER ALLOW CHILDREN
TO TOUCH GLASS.**



INSTALLER: Leave this manual with the appliance.
CONSUMER: Retain this manual for future reference.

PLEASE READ THE INSTALLATION & OPERATING INSTRUCTIONS BEFORE USING APPLIANCE.

Thank you and congratulations on your purchase of a Vermont Castings Group fireplace.

IMPORTANT: Read all instructions and warnings carefully before starting installation.

Failure to follow these instructions fully may result in a possible fire hazard and will void the warranty.

| | | | |
|---|-----------|--|-----------|
| Important Safety Information | 3 | Operating Instructions Electronic Ignition..... | 35 |
| Code Approval | 4 | What To Do If You Smell Gas..... | 35 |
| Product Specifications..... | 5 | Lighting Electronic Ignition | 35 |
| High Elevations | 6 | To Turn Off Gas..... | 35 |
| Gas Pressures | 6 | Check Gas Pressure - Signature Command System | 36 |
| Gas Specifications, Orifice Sizes | 6 | Electrical Installation - SCS | 36 |
| Fireplace & Framing Dimensions..... | 7 | Electrical Wiring | 36 |
| Pre-Installation Information | | Junction Box Wiring | 37 |
| Before You Start..... | 9 | Command Center Wall Installation..... | 37 |
| Fireplace Framing | 9 | Wall Switch Installation | 37 |
| Fireplace Location..... | 10 | Signature Command System Wiring Diagram | 38 |
| Clearances | 11 | Optional Fan/Blower System - SCS | 39 |
| Securing Fireplace to Floor or Framing | 12 | BLOTSC Wiring Diagram..... | 39 |
| Finishing Material..... | 12 | BLOT Automatic Thermostat Blower..... | 40 |
| Venting Installation..... | 13 | FK-12 Manual Blower | 40 |
| General Venting | | Operating Instructions - SCS | 41 |
| Termination Location | 13 | What To Do If You Smell Gas..... | 41 |
| Termination Clearances..... | 15 | Operating Instructions..... | 42 |
| Assembling Vent Pipes..... | 15 | To Turn Off Gas..... | 42 |
| Rear Vent Installation Only | 16 | Signature Command System..... | 43 |
| How to Use the Vent Graph..... | 17 | Operation Instructions..... | 43 |
| Vent Pipe Clearances | 18 | Glass Removal..... | 46 |
| Rear Vent Applications & Installation | 19 | Log Placement..... | 46 |
| Top Vent Sidewall Applications & Installation..... | 20 | Rockwool Placement | 46 |
| Vertical Sidewall Applications & Installation..... | 22 | Log Placement | 47 |
| Below Grade Installation | 24 | Lava Rock and Ember Placement | 47 |
| Vertical Through-the-Roof | | Cleaning and Maintenance | 48 |
| Applications & Installation..... | 25 | Burner, Pilot and Control Compartment..... | 48 |
| Fireplace Installation..... | 27 | Pilot Flame | 48 |
| Check Gas Type..... | 27 | Burner Flame | 48 |
| Gas Pipe Installation..... | 28 | Vent System..... | 49 |
| Check Gas Pressure - Millivolt..... | 29 | Glass Door..... | 49 |
| Electrical Installation..... | 29 | Logs | 49 |
| Electrical Wiring..... | 29 | Rock Wool | 49 |
| Remote Wall Mounted Switch | 30 | Troubleshooting | 50 |
| Remote Wall Switch..... | 30 | Replacement Parts | 54 |
| Optional DC Remote Systems | 30 | Firebox Components..... | 54 |
| Electronic Pilot Ignition Wiring | 31 | Standing Pilot - Millivolt Control | 56 |
| Optional Fan/Blower Systems..... | 31 | Electronic Ignition..... | 58 |
| Operating Instructions - Millivolt | 32 | Signature Command System | 59 |
| What To Do If You Smell Gas..... | 32 | Logs | 61 |
| Lighting Pilot for the First Time | 32 | Venting Components..... | 62 |
| Lighting Pilot | 33 | Massachusetts Requirements..... | 66 |
| Lighting Burner..... | 34 | Warranty | 67 |
| To Turn Off Gas..... | 34 | Energuide Efficiencies | 68 |

INSTALLER

Please leave these instructions with the appliance.

OWNER

Please retain these instructions for future reference.

| | |
|---------|---|
| WARNING | <ul style="list-style-type: none"> • Read this owner’s manual carefully and completely before trying to assemble, operate, or service this fireplace. • Any change to this fireplace or its controls can be dangerous. • Improper installation or use of this fireplace can cause serious injury or death from fire, burns, explosions, electrical shock and carbon monoxide poisoning. |
|---------|---|

This fireplace is a vented product. This fireplace must be properly installed by a qualified service person. The glass door must be properly seated and sealed. If this unit is not properly installed by a qualified service person with glass door properly seated and sealed, combustion leakage can occur.

CARBON MONOXIDE POISONING: Early signs of carbon monoxide poisoning are similar to the flu with headaches, dizziness and/or nausea. If you have these signs, the fireplace may not have been installed properly. Get fresh air at once! Have the fireplace inspected and serviced by a qualified service person. Some people are more affected by carbon monoxide than others. These include pregnant women, people with heart or lung disease or anemia, those under the influence of alcohol, and those at high altitudes.

Propane/LP gas and natural gas are both odorless. An odor-making agent is added to each of these gases. The odor helps you detect a gas leak. However, the odor added to these gases can fade. Gas may be present even though no odor exists.

Make certain you read and understand all warnings. Keep this manual for reference. It is your guide to safe and proper operation of this fireplace.

1. This appliance is only for use with the type of gas indicated on the rating plate. This appliance is not convertible for use with other gases unless a certified kit is used.
2. For propane/LP fireplace, do not place propane/LP supply tank(s) inside any structure. Locate propane/LP supply tank(s) outdoors. To prevent performance problems, do not use propane/LP fuel tank of less than 100 lbs. capacity.
3. If you smell gas
 - shut off gas supply.
 - do not try to light any appliance.
 - do not touch any electrical switch; do not use any phone in your building .
 - immediately call your gas supplier from a neighbor’s phone. Follow the gas supplier’s instructions.

4. Never install the fireplace
 - in a recreational vehicle
 - where curtains, furniture, clothing, or other flammable objects are less than 42" from the front, top, or sides of the fireplace
 - in high traffic areas
 - in windy or drafty areas
5. This fireplace reaches high temperatures. Keep children and adults away from hot surfaces to avoid burns or clothing ignition. Fireplace will remain hot for a time after shutdown. Allow surfaces to cool before touching.
6. Young children should be carefully supervised when they are in the same room as the appliance. Toddlers, young children and others may be susceptible to accidental contact burns. A physical barrier is recommended if there are at risk individuals in the house. To restrict access to a fireplace or stove, install an adjustable safety gate to keep toddlers, young children and other at risk individuals out of the room and away from hot surfaces.
7. Do not modify fireplace under any circumstances. Any parts removed for servicing must be replaced prior to operating fireplace.
8. Turn fireplace off and let cool before servicing, installing, or repairing. Only a qualified service person should install, service, or repair the fireplace. Have burner system inspected annually by a qualified service person.
9. You must keep control compartments, burners, and circulating air passages clean. More frequent cleaning may be needed due to excessive lint and dust. Turn off the gas valve and pilot light before cleaning fireplace.
10. Have venting system inspected annually by a qualified service person. If needed, have venting system cleaned or repaired. See *Cleaning and Maintenance*, Page 48.
11. Keep the area around your fireplace clear of combustible materials, gasoline, and other flammable vapor and liquids. Do not run fireplace where these are used or stored. Do not place items such as clothing or decorations on or around fireplace.

12. Do not use this fireplace to cook food or burn paper or other objects.
13. Never place anything on top of fireplace.
14. Do not use any solid fuels (wood, coal, paper, cardboard, etc.) in this fireplace. Use only the gas type indicated on rating plate.
15. This appliance, when installed, must be electrically grounded in accordance with local codes or in the absence of local codes, with the *National Electrical Code, ANSI/NFPA 70*, or the *Canadian Electrical Code, CSA C22.1*.
16. Do not obstruct the flow of combustion and ventilation air in any way. Provide adequate clearances around air openings into the combustion chamber along with adequate accessibility clearance for servicing and proper operation.
17. When the appliance is installed directly on carpeting, tile or other combustible material other than wood flooring, you must set appliance on a metal or wood panel or hearth pad extending the full width and depth of the appliance.
18. Do not use fireplace if any part has been exposed to or has been under water. Immediately call a qualified service person to arrange for replacement of the unit.
19. Do not operate fireplace if any log is broken.
20. Do not use a blower insert, heat exchanger insert, or any other accessory not approved for use with this fireplace.
21. Do not operate the fireplace with glass door removed, cracked, or broken.

CODE APPROVAL

Direct Vent type appliances draw all combustion air from outside of the dwelling through the vent pipe. These appliances have been tested by CSA and found to comply with the established standards in the USA and Canada as follows:

LISTED VENTED GAS FIREPLACE HEATER

TESTED TO (latest edition):

CDVR: ANSI Z21.88 / CSA 2.33 STANDARDS

LISTED VENTED GAS FIREPLACE

CDVT: ANSI Z21.50 CSA 2.22 STANDARDS

A manufactured home (USA only) or mobile home OEM installation must conform with the **Manufactured Home Construction and Safety Standard, Title 24 CFR, Part 3280**, or when such a standard is not applicable, the **Standard for Manufactured Home Installations, ANSI/NCSBCS A225.1**, or **Standard for Gas Equipped Recreational Vehicles and Mobile Housing, CSA Z240.4**.

**IMPORTANT:
PLEASE READ THE FOLLOWING
CAREFULLY**

It is normal for fireplaces fabricated of steel to give off some expansion and/or contraction noises during the start up or cool down cycle. Similar noises are found with your furnace heat exchanger or car engine.

**IMPORTANT:
PLEASE READ THE FOLLOWING
CAREFULLY**

It is not unusual for gas fireplace to give off some odor the first time it is burned. This is due to the manufacturing process.

Please ensure that your room is well ventilated during burn off — open all windows.

It is recommended that you burn your fireplace for at least ten (10) hours the first time you use it. Place the fan switch in the "OFF" position during this time.

NATIONAL
FIREPLACE
INSTITUTE



CERTIFIED
www.nficertified.org

We recommend that our gas hearth products be installed and serviced by professionals who are certified in the U.S. by the National Fireplace Institute® (NFI) as NFI Gas Specialists.

WARNING

Never connect unit to private (non-utility) gas wells. This gas is commonly known as wellhead gas.

! WARNING



**HOT GLASS WILL
CAUSE BURNS.**

**DO NOT TOUCH GLASS
UNTIL COOLED.**

**NEVER ALLOW CHILDREN
TO TOUCH GLASS.**

PRODUCT SPECIFICATIONS

- This appliance has been certified for use with either natural or propane gas. See appropriate data plates.
- This appliance is not for use with solid fuels.
- The appliance is approved for bedroom or bedsitting room installations.
- The appliance must be installed in accordance with local codes if any. If none exist use the current installation code. ANSI Z223.1/NFPA 54 in the USA, CSA B149 in Canada.
- This appliance is mobile home approved.
- The appliance must be properly connected to a venting system.
- The appliance is not approved for closet installations.
- This appliance is approved to be vented with Duravent and Vermont Castings Group Twist-Lock Direct Vent Components.

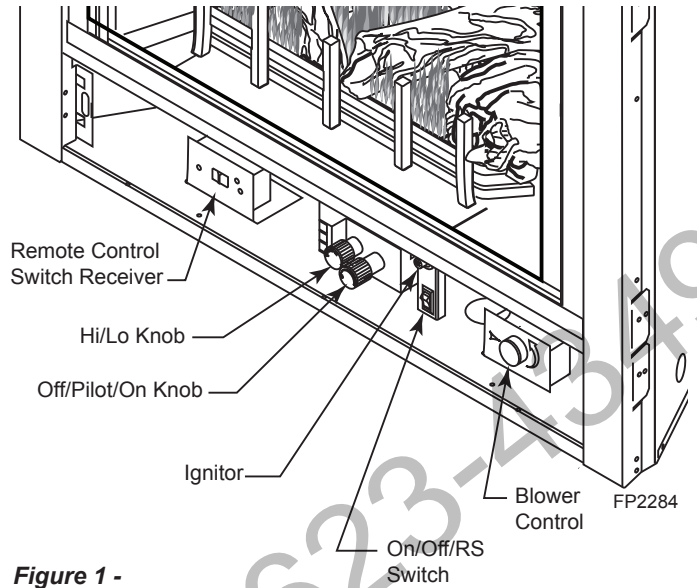

**Figure 1 -
CDV7 Series Fireplace**

The classification “noncombustible material” includes, but is not limited to stone, brick and mortar. Noncombustibles are safe to overlay the black-painted metal face (including radiant plates) and do not pose a fire hazard. Do not allow any noncombustible finish material to extend past or interfere with fireplace opening.

The classification “combustible material” includes, but is not limited to plywood, drywall and particle board. Combustible materials may contact the sides, bottom or back of firebox. Do not overlay the black painted face with combustible materials.

HIGH ELEVATIONS

Input ratings are shown in BTU per hour and are certified without deration for elevations up to 4,500 feet (1,370 m) above sea level.

For elevations above 4,500 feet (1,370 m) in USA, installations must be in accordance with the current ANSI Z223.1/NFPA 54 and/or local codes having jurisdiction.

In Canada, please consult provincial and/or local authorities having jurisdiction for installations at elevations above 4,500 feet (1,370 m).

GAS SPECIFICATIONS & ORIFICE SIZE

CDVR SERIES

| Model | Fuel | Max. Input BTU/h | Min. Input BTU/h | Orifice Size |
|--------------|------|---------------------|---------------------|-----------------|
| CDVR33NV7 | Nat. | 18,000 | 13,000 | #45 |
| CDVR33NV117 | Nat. | 18,000 | 13,000 | #45 |
| CDVR33NE7 | Nat. | 18,000 | 13,000 | #45 |
| CDVR33NSC117 | Nat. | 18,000 | 13,000 | #45 |
| CDVR36NV7 | Nat. | 20,000 | 15,000 | #44 |
| CDVR36NE7 | Nat. | 20,000 | 15,000 | #44 |
| CDVR36NSC7 | Nat. | 20,000 | 15,000 | #44 |
| CDVR42NV7 | Nat. | 24,000 | 17,000 | 2.35 mm |
| CDVR42NE7 | Nat. | 24,000 | 17,000 | 2.35 mm |
| CDVR42NSC7 | Nat. | 24,000 | 17,000 | 2.35 mm |
| CDVR47NV7 | Nat. | 24,000 | 17,000 | 2.35 mm |
| CDVR47NE7 | Nat. | 24,000 | 17,000 | 2.35 mm |
| CDVR47NSC7 | Nat. | 24,000 | 17,000 | 2.35 mm |
| CDVR33PV7 | LP | 18,000 | 13,000 | 1.28 mm |
| CDVR33PV117 | LP | 17,000 | 14,000 | 1.25 mm |
| CDVR33PE7 | LP | 18,000 | 13,000 | 1.28 mm |
| CDVR33PSC117 | LP | 17,000 | 14,000 | 1.25 mm |
| CDVR36PV7 | LP | 20,000 | 15,000 | 1.35 mm |
| CDVR36PE7 | LP | 20,000 | 15,000 | 1.35 mm |
| CDVR36PSC7 | LP | 20,000 | 15,000 | 1.35 mm |
| CDVR42PV7 | LP | 24,000 | 18,000 | 1.45 mm |
| CDVR42PE7 | LP | 24,000 | 18,000 | 1.45 mm |
| CDVR42PSC7 | LP | 24,000 | 18,000 | 1.45 mm |
| CDVR47PV7 | LP | 24,000 | 18,000 | 1.45 mm |
| CDVR47PE7 | LP | 24,000 | 18,000 | 1.45 mm |
| CDVR47PSC7 | LP | 24,000 | 18,000 | 1.45 mm |

GAS PRESSURES

| | Natural | Propane (LP) |
|-------------------|------------|--------------|
| Inlet Minimum | 5.5" w.c. | 11.0" w.c. |
| Inlet Maximum | 14.0" w.c. | 14.0" w.c. |
| Manifold Pressure | 3.5" w.c. | 10.0" w.c. |

GAS SPECIFICATIONS & ORIFICE SIZE

CDVT SERIES

| Model | Fuel | Max. Input BTU/h | Min. Input BTU/h | Orifice Size |
|------------|------|---------------------|---------------------|-----------------|
| CDVT33NV7 | Nat. | 18,000 | 13,000 | #45 |
| CDVT33PV7 | LP | 18,000 | 13,000 | 1.28 mm |
| CDVT33NE7 | Nat. | 18,000 | 13,000 | #45 |
| CDVT33PE7 | LP | 18,000 | 13,000 | 1.28 mm |
| CDVT33NSC7 | Nat. | 18,000 | 13,000 | #45 |
| CDVT33PSC7 | LP | 18,000 | 13,000 | 1.28 mm |
| CDVT36NV7 | Nat. | 20,000 | 15,000 | #44 |
| CDVT36PV7 | LP | 20,000 | 15,000 | 1.35 mm |
| CDVT36NE7 | Nat. | 20,000 | 15,000 | #44 |
| CDVT36PE7 | LP | 20,000 | 15,000 | 1.35 mm |
| CDVT36NSC7 | Nat. | 20,000 | 15,000 | #44 |
| CDVT36PSC7 | LP | 20,000 | 15,000 | 1.35 mm |
| CDVT42NV7 | Nat. | 24,000 | 17,000 | 2.35 mm |
| CDVT42PV7 | LP | 24,000 | 18,000 | 1.45 mm |
| CDVT42NE7 | Nat. | 24,000 | 17,000 | 2.35 mm |
| CDVT42PE7 | LP | 24,000 | 18,000 | 1.45 mm |
| CDVT42NSC7 | Nat. | 24,000 | 17,000 | 2.35 mm |
| CDVT42PSC7 | LP | 24,000 | 18,000 | 1.45 mm |
| CDVT47NV7 | Nat. | 24,000 | 17,000 | 2.35 mm |
| CDVT47PV7 | LP | 24,000 | 18,000 | 1.45 mm |
| CDVT47NE7 | Nat. | 24,000 | 17,000 | 2.35 mm |
| CDVT47PE7 | LP | 24,000 | 18,000 | 1.45 mm |
| CDVT47NSC7 | Nat. | 24,000 | 17,000 | 2.35 mm |
| CDVT47PSC7 | LP | 24,000 | 18,000 | 1.45 mm |

COLD CLIMATE INSULATION

If you live in a cold climate, seal all cracks around your appliance, and wherever cold air could enter the room, with noncombustible material. It is especially important to insulate the outside chase cavity between the studs and under the floor on which the appliance rests, if the floor is above ground level.

NOTE: Refer to cold climate pilot information on Page 43 for more information on standing pilot vs. intermittent pilot options.

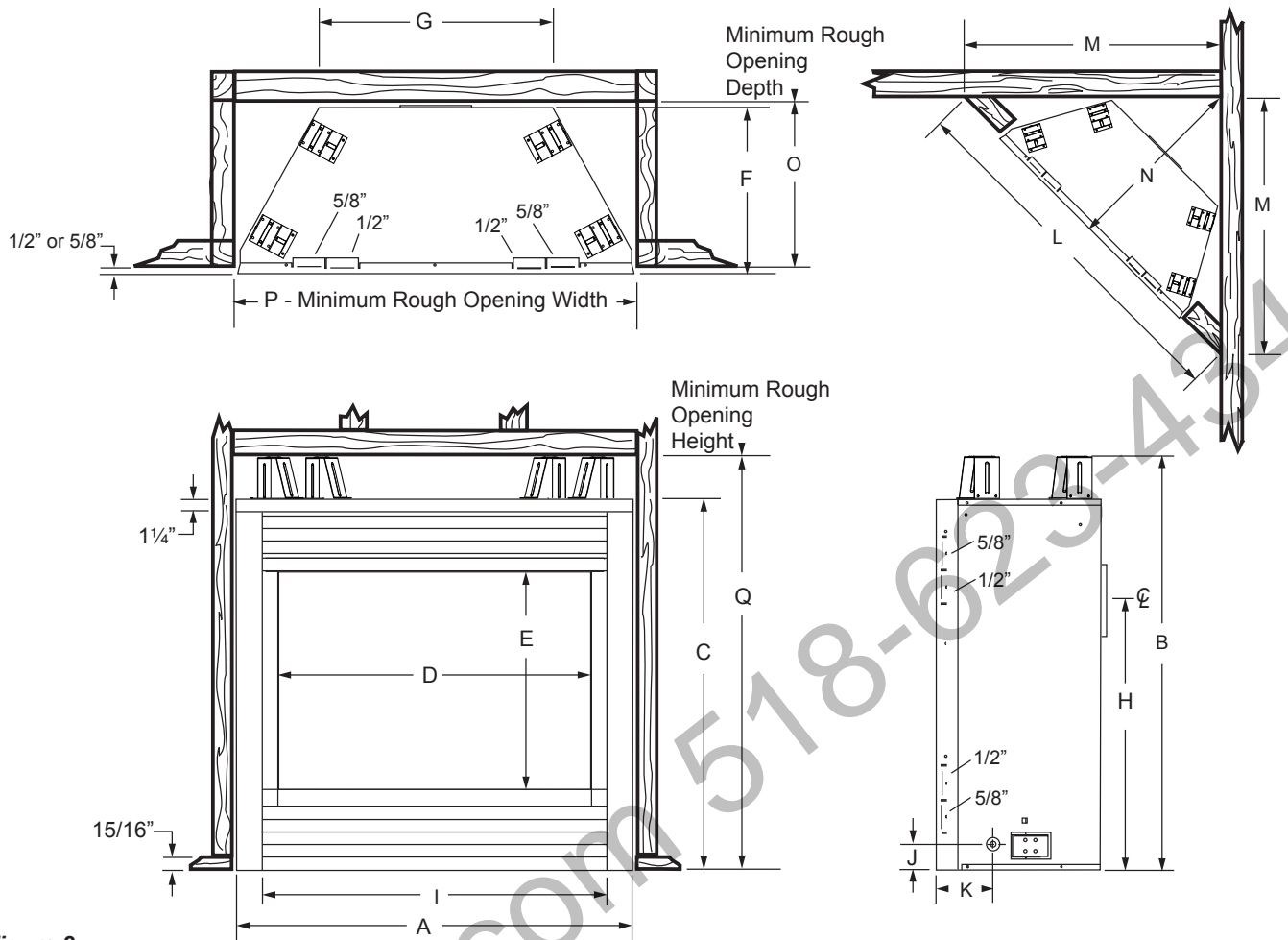

Figure 2 - CDVR Series Fireplace Dimensions

NOTE: Models CDVR33SC7 & CDVR33V117 have no standoffs on top of unit.

| | CDVR33(V)(SC)117 | CDVR33(V,E)7 | CDVR36(V,E,SC)7 | CDVR42(V,E,SC)7 | CDVR47(V,E,SC)7 |
|---------------------------|---|---|---|---|---|
| A | 33 ³ / ₈ " (848 mm) | 33" (838 mm) | 37 ¹ / ₁₆ " (941 mm) | 41" (1041 mm) | 47" (1194 mm) |
| B | see note | 35 ⁵ / ₈ " (905 mm) | 38 ⁵ / ₈ " (981 mm) | 38 ⁵ / ₈ " (981 mm) | 38 ⁵ / ₈ " (981 mm) |
| C | 31 ¹¹ / ₁₆ " (805 mm) | 31 ¹¹ / ₁₆ " (805 mm) | 34 ⁹ / ₁₆ " (878 mm) | 34 ⁹ / ₁₆ " (878 mm) | 34 ⁹ / ₁₆ " (878 mm) |
| D | 27 ³ / ₁₆ " (691 mm) | 27 ³ / ₁₆ " (691 mm) | 29 ¹ / ₁₆ " (738 mm) | 33 ¹ / ₁₆ " (840 mm) | 39 ¹ / ₁₆ " (992 mm) |
| E | 15 ³ / ₁₆ " (386 mm) | 15 ³ / ₁₆ " (386 mm) | 20 ³ / ₈ " (518 mm) | 20 ³ / ₈ " (518 mm) | 20 ³ / ₈ " (518 mm) |
| F | 11 ³ / ₄ " (299 mm) | 14 ³ / ₁₆ " (360 mm) | 15 ³ / ₄ " (400 mm) | 15 ³ / ₄ " (400 mm) | 15 ³ / ₄ " (400 mm) |
| G | 21 ¹ / ₂ " (546 mm) | 21 ³ / ₈ " (546 mm) | 21 ⁷ / ₈ " (556 mm) | 25 ⁷ / ₈ " (657 mm) | 31 ⁷ / ₈ " (810 mm) |
| H | 21 ¹⁵ / ₁₆ " (557 mm) | 21 ¹⁵ / ₁₆ " (557 mm) | 25 ¹ / ₄ " (641 mm) | 25 ¹ / ₄ " (641 mm) | 25 ¹ / ₄ " (641 mm) |
| I | 29 ⁷ / ₈ " (759 mm) | 29 ⁷ / ₈ " (759 mm) | 32" (813 mm) | 36" (914 mm) | 42" (1067 mm) |
| J | 2 ⁵ / ₁₆ " (59 mm) | 2 ⁵ / ₁₆ " (59 mm) | 2 ³ / ₈ " (60 mm) | 2 ³ / ₈ " (60 mm) | 2 ³ / ₈ " (60 mm) |
| K | 5" (127 mm) | 7 ³ / ₁₆ " (183 mm) | 5 ⁷ / ₁₆ " (138 mm) | 5 ⁷ / ₁₆ " (138 mm) | 5 ⁷ / ₁₆ " (138 mm) |
| Framing Dimensions | | | | | |
| L | 45" (1143 mm) | 48 ³ / ₄ " (1238 mm) | 52 ⁷ / ₁₆ " (1332 mm) | 56 ⁷ / ₁₆ " (1434 mm) | 62 ⁷ / ₁₆ " (1586 mm) |
| M | 33" (838 mm) | 34 ¹ / ₂ " (876 mm) | 37 ¹ / ₁₆ " (941 mm) | 40" (1016 mm) | 44 ¹ / ₈ " (1121 mm) |
| N | 24" (610 mm) | 24 ³ / ₈ " (619 mm) | 26 ¹ / ₄ " (667 mm) | 28 ¹ / ₄ " (718 mm) | 31 ¹ / ₄ " (794 mm) |
| O | 11 ¹ / ₄ " (286 mm) | 13 ¹¹ / ₁₆ " (347 mm) | 15 ¹ / ₄ " (387 mm) | 15 ¹ / ₄ " (387 mm) | 15 ¹ / ₄ " (387 mm) |
| P | 33 ³ / ₈ " (854 mm) | 33 ¹ / ₄ " (845 mm) | 37 ¹ / ₂ " (953 mm) | 41 ¹ / ₄ " (1048 mm) | 47 ¹ / ₄ " (1200 mm) |
| Q | 32 ¹ / ₄ " (819 mm) | 35 ⁷ / ₈ " (911 mm) | 39" (991 mm) | 39" (991 mm) | 39" (991 mm) |

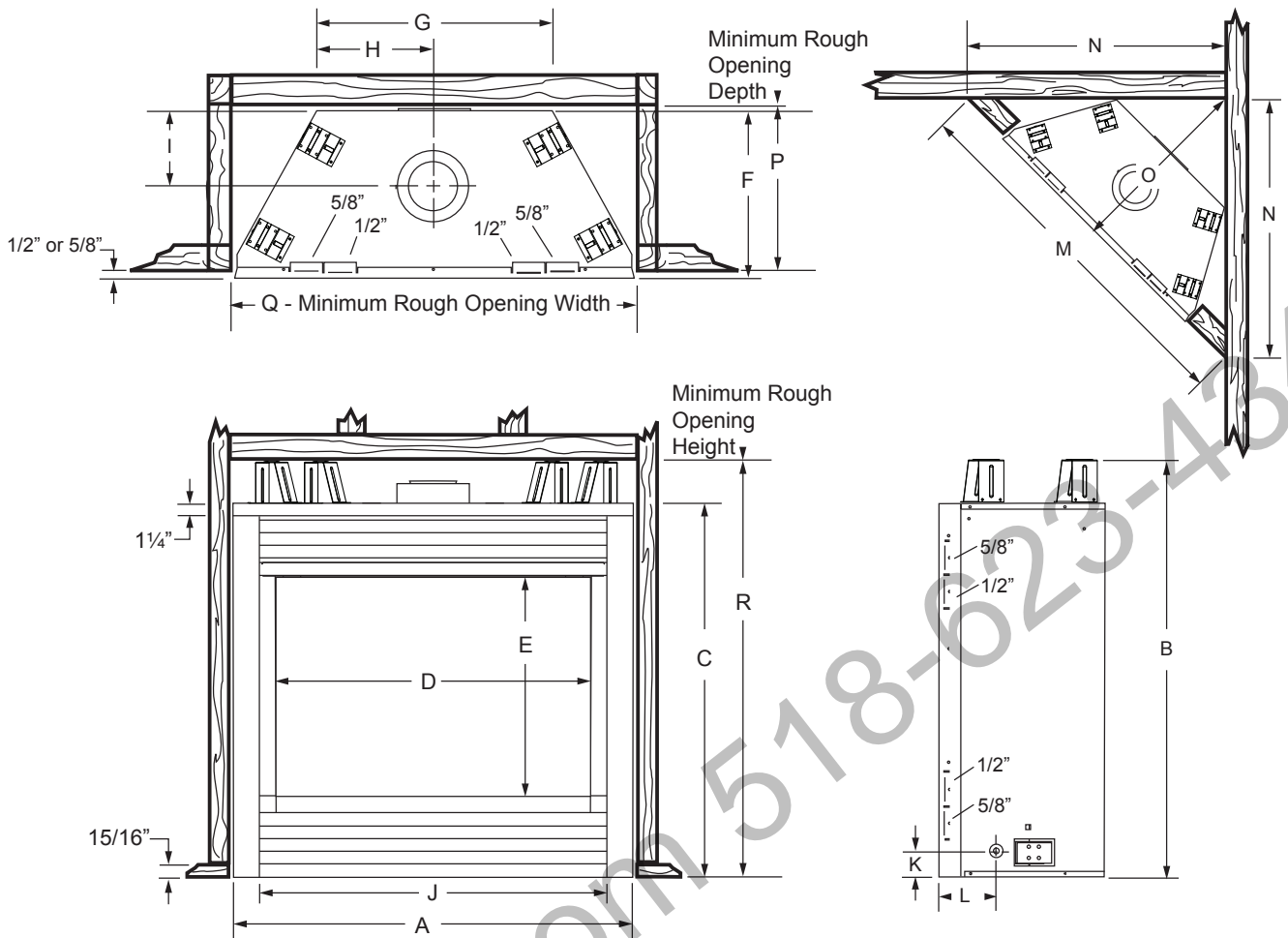

Figure 3 -
CDVT Series Fireplace Dimensions

| | CDVT33(V,E,SC)7 | CDVT36 (V,E,SC)7 | CDVT42 (V,E,SC)7 | CDVT47 (V,E,SC)7 |
|---------------------------|---|---|---|---|
| A | 33" (38 mm) | 37 ¹ / ₁₆ " (941 mm) | 41" (1041 mm) | 47" (1194 mm) |
| B | 35 ⁵ / ₈ " (905 mm) | 38 ⁵ / ₈ " (981 mm) | 38 ⁵ / ₈ " (981 mm) | 38 ⁵ / ₈ " (981 mm) |
| C | 31 ¹¹ / ₁₆ " (805 mm) | 34 ⁹ / ₁₆ " (878 mm) | 34 ⁹ / ₁₆ " (878 mm) | 34 ⁹ / ₁₆ " (878 mm) |
| D | 27 ³ / ₁₆ " (691 mm) | 29 ¹ / ₁₆ " (738 mm) | 33 ¹ / ₁₆ " (840 mm) | 39 ¹ / ₁₆ " (992 mm) |
| E | 15 ³ / ₁₆ " (386 mm) | 20 ³ / ₈ " (518 mm) | 20 ³ / ₈ " (518 mm) | 20 ³ / ₈ " (518 mm) |
| F | 14 ³ / ₁₆ " (360 mm) | 15 ³ / ₄ " (400 mm) | 15 ³ / ₄ " (400 mm) | 15 ³ / ₄ " (400 mm) |
| G | 21 ³ / ₈ " (546 mm) | 21 ⁷ / ₈ " (556 mm) | 25 ⁷ / ₈ " (657 mm) | 31 ⁷ / ₈ " (810 mm) |
| H | 10 ¹ / ₁₆ " (272 mm) | 10 ¹⁵ / ₁₆ " (278 mm) | 12 ¹⁵ / ₁₆ " (329 mm) | 15 ¹⁵ / ₁₆ " (405 mm) |
| I | 6 ¹ / ₂ " (165 mm) | 6 ¹ / ₂ " (165 mm) | 6 ¹ / ₂ " (165 mm) | 6 ¹ / ₂ " (165 mm) |
| J | 29 ⁷ / ₈ " (759 mm) | 32" (813 mm) | 36" (914 mm) | 42" (1067 mm) |
| K | 2 ⁵ / ₁₆ " (59 mm) | 2 ³ / ₈ " (60 mm) | 2 ³ / ₈ " (60 mm) | 2 ³ / ₈ " (60 mm) |
| L | 7 ³ / ₁₆ " (183 mm) | 5 ⁷ / ₁₆ " (138 mm) | 5 ⁷ / ₁₆ " (138 mm) | 5 ⁷ / ₁₆ " (138 mm) |
| Framing Dimensions | | | | |
| M | 48 ³ / ₄ " (1238 mm) | 52 ⁷ / ₁₆ " (1332 mm) | 56 ⁷ / ₁₆ " (1434 mm) | 62 ⁷ / ₁₆ " (1586 mm) |
| N | 34 ¹ / ₂ " (876 mm) | 37 ¹ / ₁₆ " (941 mm) | 40" (1016 mm) | 44 ¹ / ₈ " (1121 mm) |
| O | 24 ³ / ₈ " (619 mm) | 26 ¹ / ₄ " (667 mm) | 28 ¹ / ₄ " (718 mm) | 31 ¹ / ₄ " (794 mm) |
| P | 13 ¹¹ / ₁₆ " (347 mm) | 15 ¹ / ₄ " (387 mm) | 15 ¹ / ₄ " (387 mm) | 15 ¹ / ₄ " (387 mm) |
| Q | 33 ¹ / ₄ " (845 mm) | 37 ¹ / ₂ " (953 mm) | 41 ¹ / ₄ " (1048 mm) | 47 ¹ / ₄ " (1200 mm) |
| R | 35 ⁷ / ₈ " (911 mm) | 39" (991 mm) | 39" (991 mm) | 39" (991 mm) |

BEFORE YOU START

Read this homeowner manual thoroughly and follow all instructions carefully. Inspect all contents for shipping damage and immediately inform your dealer if any damage is found. Do not install any unit with damaged, incomplete, or substitute parts. Check your packing list to verify that all listed parts have been received. You should have the following:

- Fireplace (Firebox and Burner System)
- Log Set
- Rock Wool
- Volcanic Rock

ITEMS REQUIRED FOR INSTALLATION

Tools:

- Phillips Screwdriver
- Hammer
- Saw and/or saber saw
- Electric Drill and Bits
- Pliers
- Square
- Caulking Material (Noncombustible)
- Fireplace Surround Material (Noncombustible)
- Piping Complying with Local Codes
- Pipe Sealant Approved for use with Propane/LPG (Resistant to Sulfur Compounds)

Building Supplies:

- Framing Materials
- Wall Finishing Materials
- Level
- Tee Joint
- Measuring Tape
- Pipe Wrench

WARNING

Do not fill spaces around firebox with insulation or other materials. This could cause a fire.

FIREBOX FRAMING FOR CDVR

Firebox framing can be built before or after the appliance is set in place. Construct firebox framing following *Figure 2* for your specific installation requirements. Refer to *Figure 2* for firebox dimensions. The framing headers may rest on the top of the firebox standoffs. **Do not bring headers below top of standoffs. NOTE: CDVR33SC7 & CDVR33117 do not have standoffs.**

The firebox may be installed directly on a combustible floor or raised on a platform of an appropriate height. When the firebox is installed directly on carpeting, tile, or other combustible material, other than wood flooring, the firebox shall be installed on a metal or wood panel extending the full width and depth of the enclosure.

FIREBOX FRAMING FOR CDVT

Firebox framing can be built before or after the appliance is set in place. Construct firebox framing following *Figure 3* for your specific installation requirements. Refer to *Figure 3* for firebox dimensions. The framing headers may rest on the top of the firebox standoffs. **Do not bring headers below top of standoffs.**

69D3011

The firebox may be installed directly on a combustible floor or raised on a platform of an appropriate height. When the firebox is installed directly on carpeting, tile, or other combustible material, other than wood flooring, the firebox shall be installed on a metal or wood panel extending the full width and depth of the enclosure.

FIREPLACE LOCATION

Plan for the installation of your appliance. This includes determining where the unit is to be installed, the vent configuration to be used, framing and finishing details, and whether any optional accessories (i.e. blower, wall switch, or remote control) are desired. Consult your local building code agency to ensure compliance with local codes, including permits and inspections.

The following factors should be taken into consideration:

- Clearance to side-wall, ceiling, woodwork, and windows. Minimum clearances to combustibles **must be maintained.**
- This fireplace may be installed along a wall, across a corner, or use an exterior chase. Refer to *Figure 4* for suggested locations.
- Location should be out of high traffic areas and away from furniture and draperies due to heat from appliance.
- Never obstruct the front opening of the fireplace.
- Do **not** install in the vicinity where gasoline or other flammable liquids may be stored.
- Vent pipe routing. See *Venting* section found in this manual for allowable venting configurations.
- These units can be installed in a bedroom. See National Fuel Gas Code ANSI Z233.1/NFPA 54 — (current edition), the Uniform Mechanical Code — (current edition), and Local Building Codes for specific installation requirements.

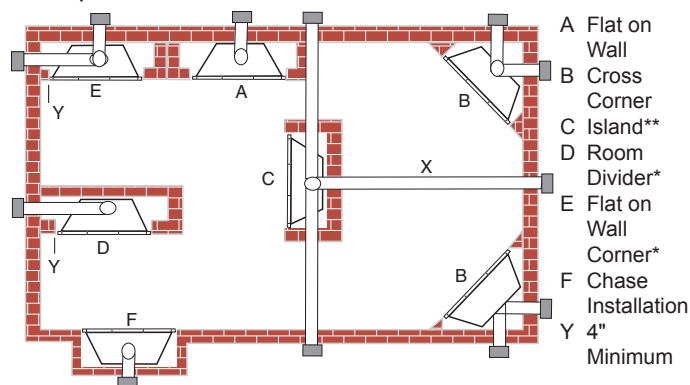

Figure 4 - Locating Gas Fireplace

** Island (C) and room divider (D) installation is possible as long as the horizontal portion of vent system (X) does not exceed 20'.

* When you install your fireplace in (D) room divider or (E) flat on wall corner positions (Y), a minimum of 4" clearance must be maintained from perpendicular wall and front of fireplace.

CLEARANCES TO COMBUSTIBLES

WARNING

Follow these instructions carefully to ensure safe installation. Failure to follow instructions exactly can create a fire hazard.

The appliance cannot be installed on a carpet, tile or other combustible material other than wood flooring. If installed on carpet or vinyl flooring, the appliance shall be installed on a metal, wood or noncombustible material panel extending full width and depth of the appliance.

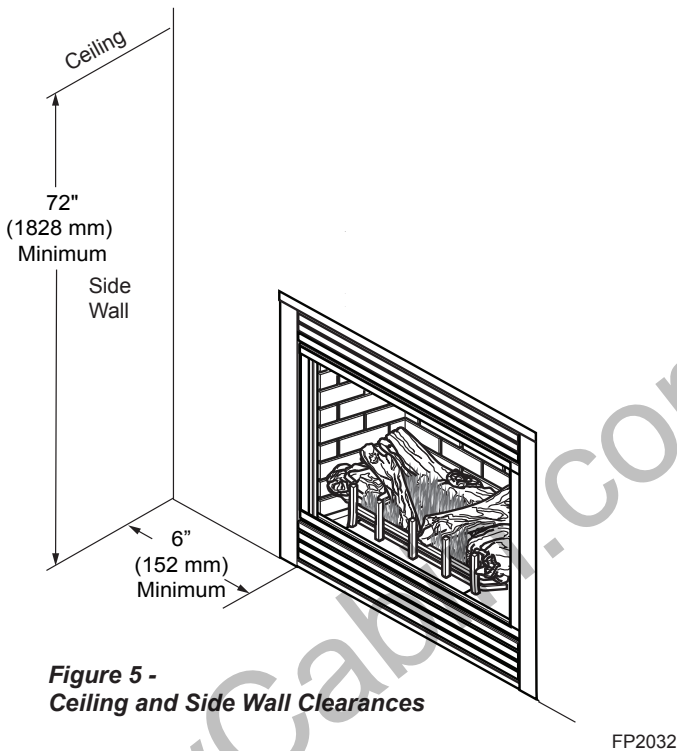
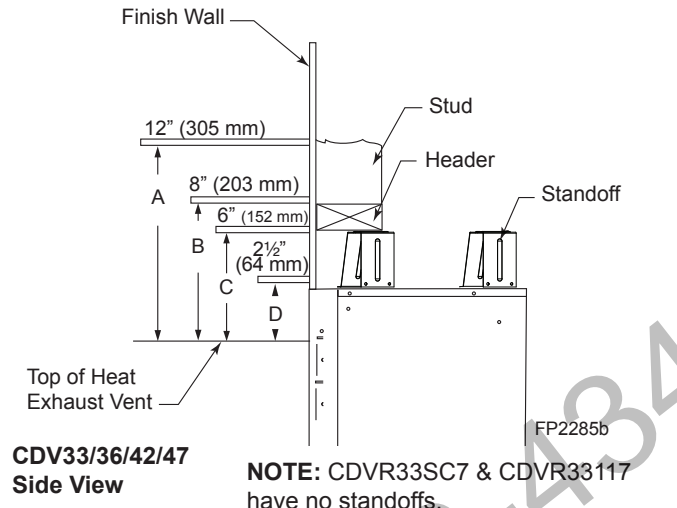

Figure 5 - Ceiling and Side Wall Clearances

MANTEL CLEARANCES

NOTE: The combustible area above the facing must not protrude more than 3/4" from the facing. If it does, it is considered a mantel and must meet the mantel requirements listed in this manual.

NOTE: The Vermont Castings Group Barrington Cabinet Mantel Model series BWC300, BWC400 and BWC500 are specially designed to comply with all mantel temperature requirements. Any custom-built mantel must comply with all clearance requirements shown in this instruction manual.



CDV33/36/42/47 Side View

NOTE: CDVR33SC7 & CDVR33117 have no standoffs.

| Ref. | CDV33 | CDV36 | CDV42/47 |
|------------------|--------------|--------------|--------------------------------|
| A | 14" (356 mm) | 12" (305 mm) | 12" (305 mm) |
| B | 11" (279 mm) | 11" (279 mm) | 9 1/2" (241 mm) |
| C | 10" (254 mm) | 10" (254 mm) | 8 1/2" (216 mm) |
| D | 8" (203 mm) | 8" (203 mm) | 6" (152 mm) |
| Optional Canopy* | 54D0648TK | 37D0286TK | 42: 37D0288TK 47: 27D0614TK |

*If an optional canopy is installed, all vertical clearances can be reduced by 4" (102 mm).

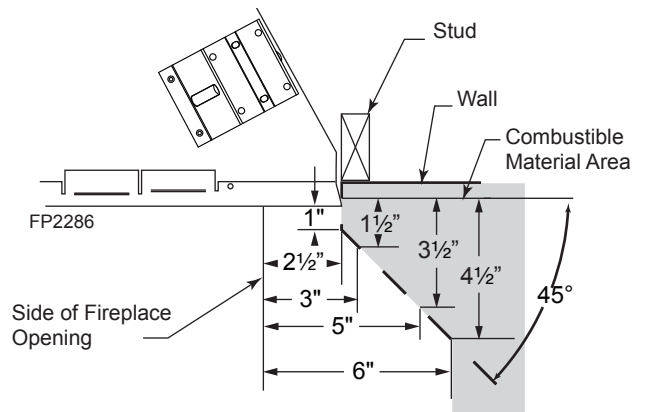
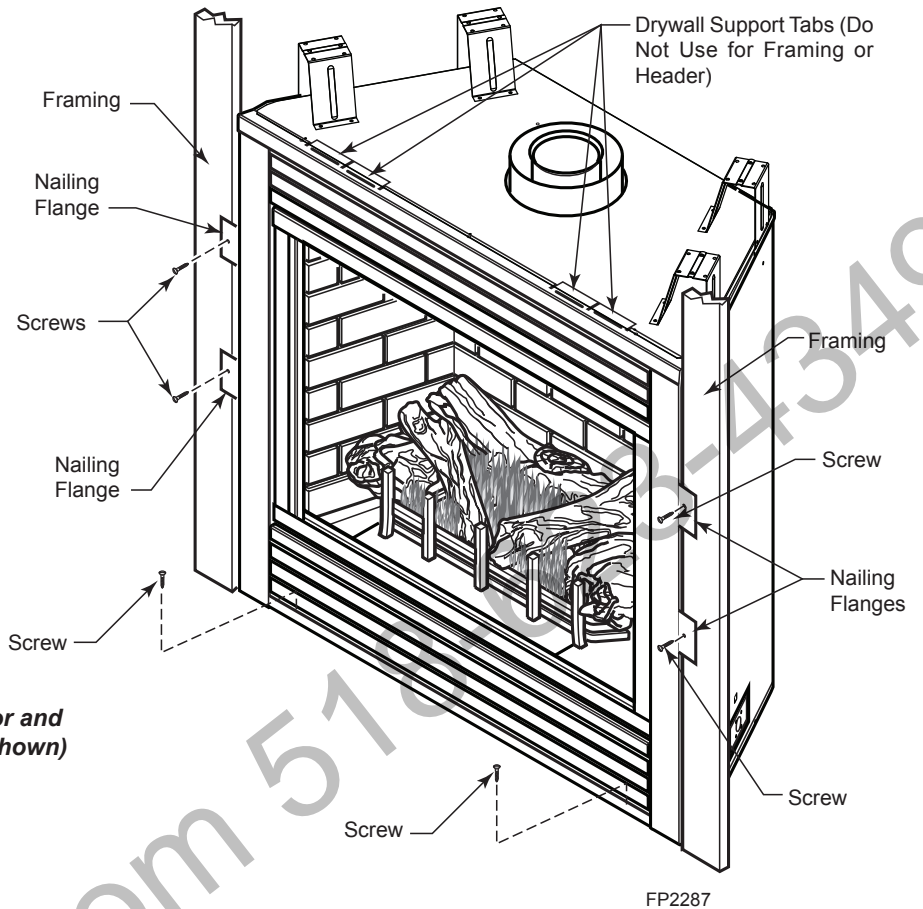

Figure 6 - Front View Mantel Clearances

WARNING

Never obstruct or modify the air inlet or outlet grilles (louvers). This may create a fire hazard.

The fireplace must be secured to the floor and/or to framing studs as shown in *Figure 7*. Use two (2) wood screws or masonry/ concrete screws to secure fireplace to the floor. Use four (4) screws to attach fireplace to framing. The side nailing flanges are 1/2" or 5/8" to accommodate different wall thickness.



**Figure 7 -
Securing Fireplace to Floor and
Framing Studs (CDVT36 shown)**

FINISHING MATERIAL

NOTE: Any wiring (i.e. remote control, wall switch, and optional fan) must be done prior to final finishing to avoid costly reconstruction.

Only noncombustible materials (i.e. brick, tile, slate, steel, or other materials with a UL fire rating of Zero) may be used to cover the black surface of the appliance. A 300°F minimum adhesive may be used to attach facing materials to the black surface. If joints between the finished wall and the fireplace surround are sealed, a 300°F minimum sealant material (General Electric RTV103 or equivalent) must be used.

WARNING

Read all instructions completely and thoroughly before attempting installation. Failure to do so could result in serious injury, property damage or loss of life. Operation of improperly installed and maintained venting system could result in serious injury, property damage or loss of life.

WARNING

This fireplace must be vented to the outside. The venting system must NEVER be attached to a chimney serving a separate solid fuel burning appliance. Each gas appliance must use a separate vent system. Do not use common vent systems.

INSTALLATION PRECAUTIONS

Consult local building codes before beginning the installation. The installer must make sure to select the proper vent system for installation. Before installing vent kit, the installer must read this fireplace manual and vent kit instructions.

Only a qualified installer/service person should install venting system. The installer must follow these safety rules:

- Wear gloves and safety glasses for protection.
- Use extreme caution when using ladders or when on rooftops.
- Be aware of electrical wiring locations in walls and ceilings.

The following actions will void the warranty on your venting system:

- Installation of any damaged venting component.
- Unauthorized modification of the venting system.
- Installation of any component part not manufactured or approved by Vermont Castings Group.
- Installation other than permitted by these instructions.

GENERAL VENTING

Your fireplace is approved to be vented either through the side wall, or vertical through the roof.

- **Only Vermont Castings Group venting components specifically approved and labelled for this fireplace may be used.**
- Flexible UL1777 listed venting may be used in any venting application where rigid direct vent components can be used. All restrictions, clearances and allowances that pertain to the rigid piping apply to the flexible venting. Flex kits may not be modified. Flex kits may be added to the end of a vent run made of rigid vent sections using pipe manufacturer's approved flex to pipe adapters. This

may occur only if doing so does not violate any of the venting length, height, routing, horizontal to vertical ratio requirements or clearance considerations detailed in this manual.

- Venting terminals shall not be recessed into a wall or siding.
- Select the amount of vertical rise desired. All horizontal run of venting must have 1/4" rise for every 12" of run towards the termination below 7½ feet of vertical rise. With 7½ feet or more vertical rise off top of fireplace, the horizontal run may run level. NEVER run vent piping downward.
- Horizontal venting which incorporates the twist lock pipe must be installed on a level plane without an inclining or declining slope.
- Horizontal venting which incorporates the use of flex venting shall have an inclining slope from the unit of 1" (25 mm) per 24" (610 mm).

There must not be any obstruction such as bushes, garden sheds, fences, decks or utility buildings within 24" (610 mm) from the front of the termination hood.

Do not locate termination hood where excessive snow or ice build up may occur. Be sure to check vent termination area after snow falls, and clear to prevent accidental blockage of venting system. When using snow blowers, make sure snow is not directed towards vent termination area.

Location of Vent Termination

It is imperative the vent termination be located observing the minimum clearances as shown on following page.

WARNING

Always maintain minimum clearances around vent systems. The minimum clearances to combustibles for horizontal vent pipe are 3" at the top* and 1" at the sides and bottom of the vent system until the pipe penetrates the nearest vertical wall (1" required). A 1" minimum clearance all around the pipe must be maintained at outside wall and on vertical runs. Do not pack the open air spaces with insulation or other materials. This could cause high temperatures and may present a fire hazard.

*** Unless the vertical run is 7½ feet or higher (top vent units only), the clearances for the horizontal run is 1" at the top.**

NOTICE

Failure to follow these instructions will void the warranty.

GENERAL VENTING INFORMATION - TERMINATION LOCATION

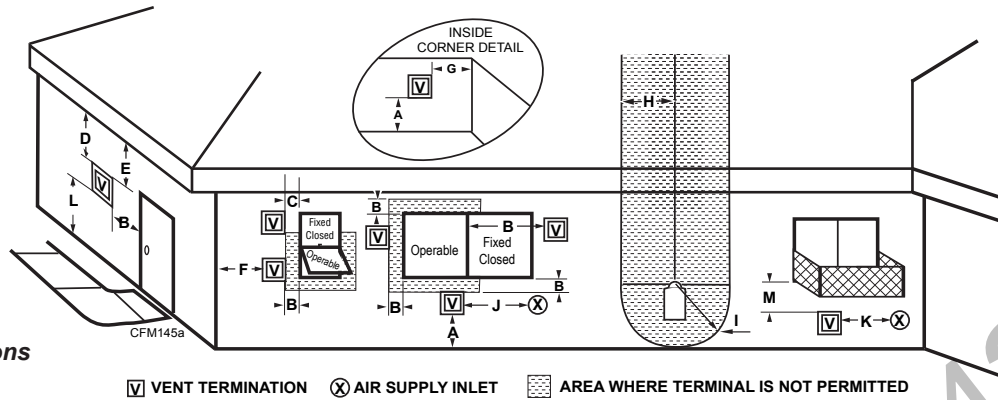

Figure 8 - Termination Locations

| | Canadian Installations ¹ | US Installations ² |
|--|--|--|
| A = Clearance above grade, veranda, porch, deck, or balcony | 12" (30 cm) | 12" (30 cm) |
| B = Clearance to window or door that may be opened | 6" (15 cm) for appliances < 10,000 BTU/h (3kW), 12" (30 cm) for appliances > 10,000 Btuh (3kW) and < 100,000 BTU/h (30kW), 36" (91 cm) for appliances > 100,000 BTU/h (30kW) | 6" (15 cm) for appliances < 10,000 BTU/h (3kW), 9" (23 cm) for appliances > 10,000 Btuh (3kW) and < 50,000 BTU/h (15kW), 12" (30 cm) for appliances > 50,000 BTU/h (15kW) |
| C = Clearance to permanently closed window | 12" (305 mm) recommended to prevent window condensation | 12" (305 mm) recommended to prevent window condensation |
| D = Vertical clearance to ventilated soffit located above the terminal within a horizontal distance of 2' (610mm) from the center line of the terminal | 18" (458 mm) | 18" (458 mm) |
| E = Clearance to unventilated soffit | 12" (305 mm) | 12" (305 mm) |
| F = Clearance to outside corner | see next page | see next page |
| G = Clearance to inside corner (see next page) | see next page | see next page |
| H = Clearance to each inside of center line extended above meter/regulator assembly | 3' (91 cm) within a height of 15' (5 m) above the meter/regulator assembly | 3' (91 cm) within a height of 15' (5 m) above the meter/regulator assy |
| I = Clearance to service regulator vent outlet | 3' (91 cm) | 3' (91 cm) |
| J = Clearance to nonmechanical air supply inlet to building or the combustion air inlet to any other appliances | 6" (15 cm) for appliances < 10,000 BTU/h (3kW), 12" (30 cm) for appliances > 10,000 BTU/h (3kW) and < 100,000 Btuh (30kW), 36" (91 cm) for appliances > 100,000 BTU/h (30kW) | 6" (15 cm) for appliances < 10,000 BTU/h (3kW), 9" (23 cm) for appliances > 10,000 BTU/h (3kW) and < 50,000 BTU/h (15kW), 12" (30 cm) for appliances > 50,000 BTU/h (15kW) |
| K = Clearance to a mechanical air supply inlet | 6' (1.83 m) | 3' (91 cm) above if within 10' (3 m) horizontally |
| L = Clearance above paved sidewalk or paved driveway located on public property | 7' (2.13 m)† | 7' (2.13 m)† |
| M = Clearance under veranda, porch, deck or balcony | 12" (30 cm)‡ | 12" (30cm)‡ |

1 In accordance with the current CSA-B149 Installation Codes
 2 In accordance with the current ANSI Z223.1/NFPA 54 National Fuel Gas Codes
 † A vent shall not terminate directly above a sidewalk or paved driveway which is located between two single family dwellings and serves both dwellings
 ‡ only permitted if veranda, porch, deck or balcony is fully open on a minimum 2 sides beneath the floor:

NOTE: 1. Local codes or regulations may require different clearances.
 2. The special venting system used on Direct Vent Fireplaces are certified as part of the appliance, with clearances tested and approved by the listing agency.
 3. Vermont Castings Group assumes no responsibility for the improper performance of the appliance when the venting system does not meet these requirements.

Termination Clearances

Termination clearances for buildings with combustible and noncombustible exteriors.

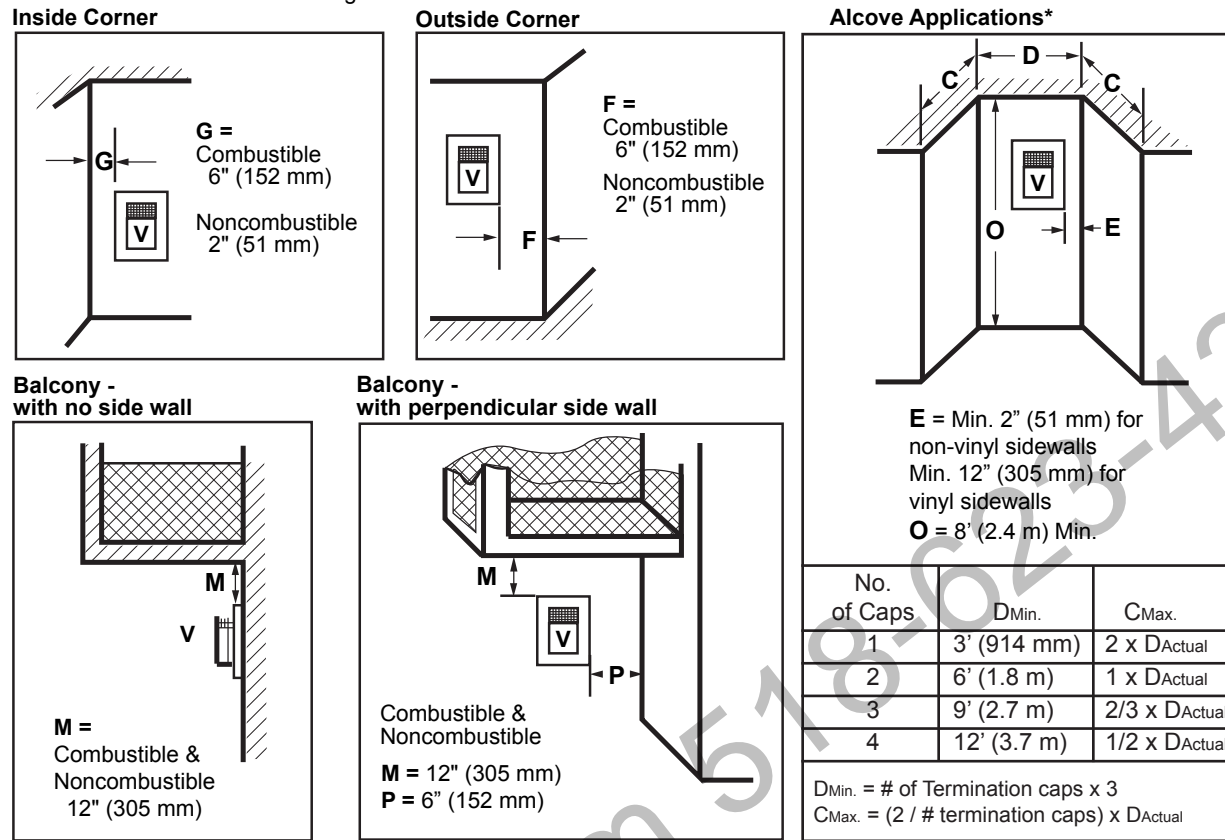

584-15

***NOTE:** Termination in an alcove space (spaces open only on one side and with an overhang) is permitted with the dimensions specified for vinyl or non-vinyl siding and soffits. 1. There must be a 3' (914 mm) minimum between termination caps. 2. All mechanical air intakes within 10' (1 m) of a termination cap must be a minimum of 3' (914 mm) below the termination cap. 3. All gravity air intakes within 3' (914 mm) of a termination cap must be a minimum of 1' (305 mm) below the termination cap.

Figure 9 - Termination Clearances

GENERAL INFORMATION ASSEMBLING VENT PIPES

USA Installations

The venting system must conform to local codes and/or the current National Fuel Code ANSI Z223.1/NFPA 54.

Only venting components manufactured or approved by Vermont Castings Group may be used in Direct Vent systems.

Canadian Installations

The venting system must be installed in accordance with the current CSA-B149.1 installation code.

FLEX VENT PIPES

Secure flex vent pipe in place with a hose clamp (provided).

*Be sure the flex pipe overlaps at least 1" (25 mm) onto the collars of the fireplace and termination. If the termination has an internal bead, be sure to overlap and secure 1" (25 mm) past the bead.

* Be sure the vent is actually crushed before proceeding. Apply a tug to be sure the vent will not slip off the collars. Repeat process with 7" flex vent pipe. The same procedure must be performed on the vent side.

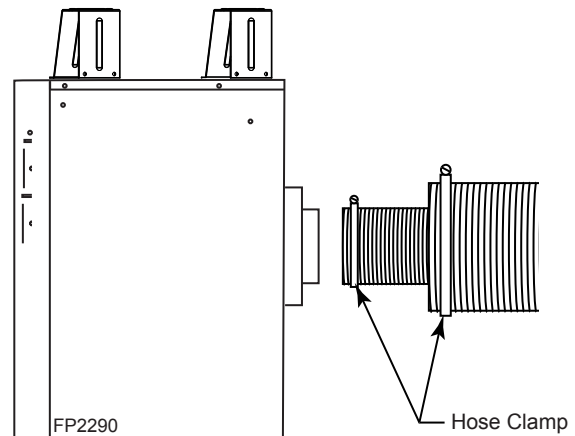

Figure 10 - Secure Flex Vent Pipe with Hose Clamps.

TWIST LOCK PIPES

When using twist lock pipe it is not necessary to use sealant on the joints.

To join twist lock pipes together, simply align the beads of the male end with the grooves of the female end, twisting the pipe until the flange on the female end contacts external flange on the male end. It is recommended that you secure the joints with three (3) sheet metal screws, however, this is not mandatory with twist lock pipe. *Figure 11*

NOTE: Sealant is not required to assemble fireplace venting. Do not use silicone sealant at the inner flue exhaust connections.

To make it easier to assembly the joints, we suggest putting a lubricant (Vaseline or similar) on the male end of the twist lock pipe prior to assembly.

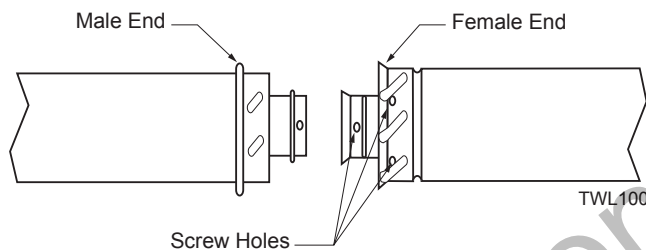

Figure 11 - Twist-lock Pipe Joints

REAR VENT INSTALLATION ONLY:

Install the 4" (102 mm) vent pipe to the appliance inner collar and secure with three (3) stainless steel sheet metal screws. Install the 7" (178 mm) vent pipe to the appliance outer collar. Secure pipe to the rear cover plate using the tabs and three (3) sheet metal screws. If a 45° or 90° elbow is being used, attach the elbow to the appliance in the same manner then attach the venting to the elbow.

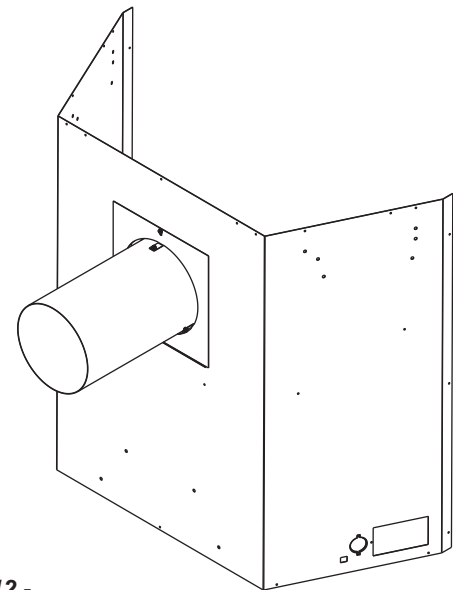
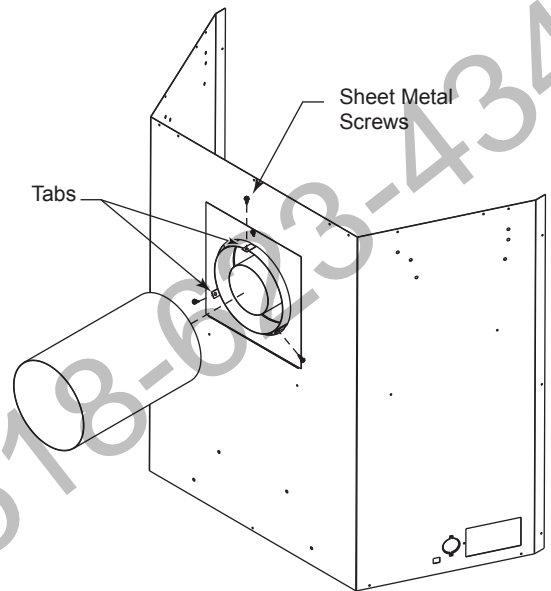

Figure 12 - Rear Vent Installation

KT1129

HOW TO USE THE VENT GRAPH

The Vent Graph should be read in conjunction with the following vent installation instructions to determine the relationship between the vertical and horizontal dimensions of the vent system.

1. Determine the height of the center of the horizontal vent pipe exiting through the outer wall. Using this dimension on the Sidewall Vent Graph, *Figure 13*, locate the point intersecting with the slanted graph line.
2. From the point of this intersection, draw a vertical line to the bottom of the graph.
3. Select the indicated dimension, and position the fireplace in accordance with same.

EXAMPLE A:

If the vertical dimension from the floor of the unit is 11' (3.4 m) the horizontal run to the face of the outer wall must not exceed 14' (4.3 m).

EXAMPLE B:

If the vertical dimension from the floor of the unit is 7' (2.1 m), the horizontal run to the face of the outer wall must not exceed 8' (2.4 m).

Refer to *Page 24* for snorkel requirements.

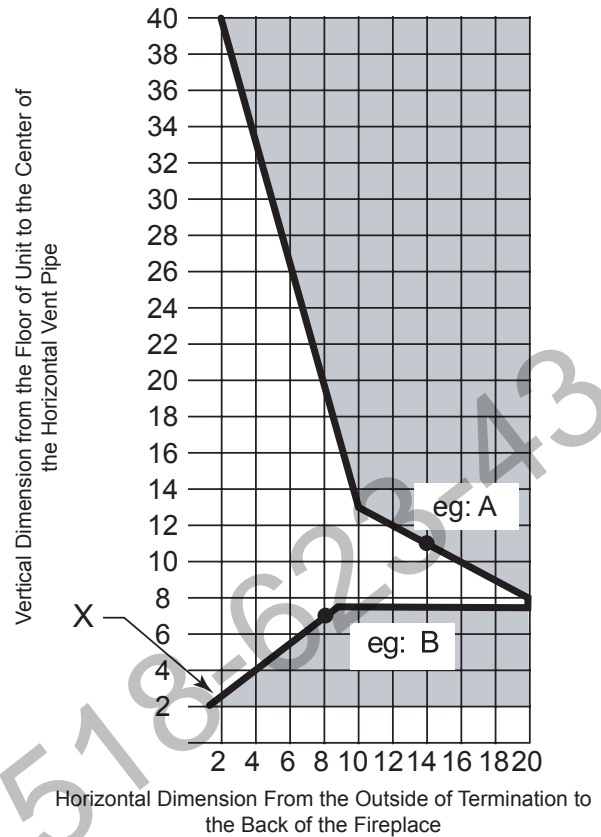

X = 22" minimum for 33" Model
 X = 25¼" minimum for 36", 42" and 47" Models
 (Floor to center of horizontal pipe)

**Figure 13 -
 Side Wall Venting Graph**

VENT PIPE CLEARANCES

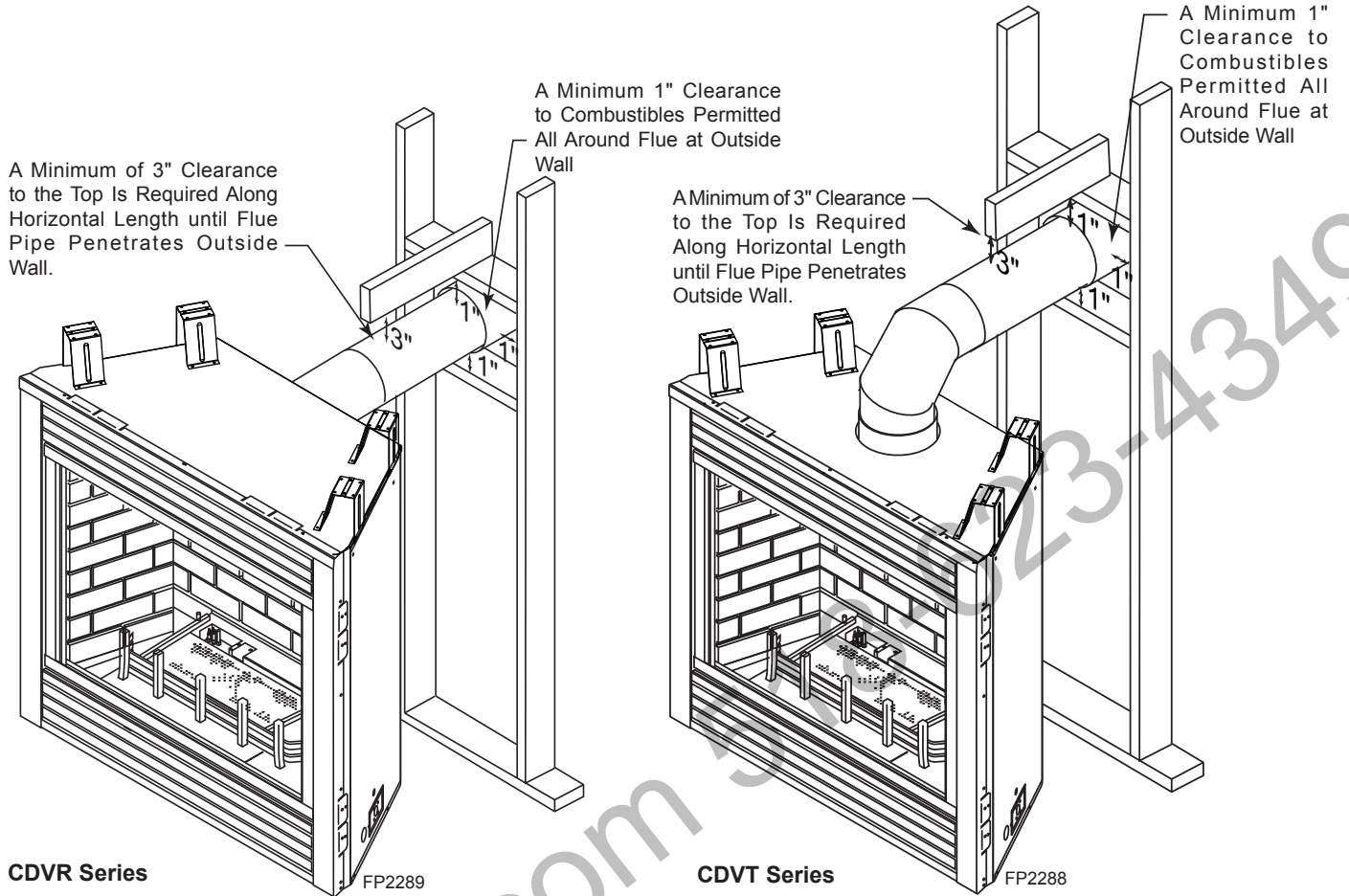

CDVR Series

FP2289

CDVT Series

FP2288

Figure 14 - Combustible Clearances for Vent Pipe

WARNING

Rear Vent: Horizontal sections of this vent system require a minimum of 3" clearances to combustibles at the top of the flue and 1" clearance at the sides and bottom *until the flue penetrates the outside wall*. A minimum 1" clearance all around the flue is acceptable at this point of penetration. Vertical sections of this vent system require a minimum of 1" clearance to combustibles on all sides of the pipe.

WARNING

Top Vent: Horizontal sections of this vent system require a minimum of 3" clearances to combustibles at the top of the flue and 1" clearance at the sides and bottom *until the flue penetrates the outside wall*. A minimum 1" clearance all around the flue is acceptable at this point of penetration. If vertical rise is 7¹/₂ feet or higher when top venting, the clearance to combustibles is 1" on all sides of the horizontal run. Vertical sections of this vent system require a minimum of 1" clearance to combustibles on all sides of the pipe.

REAR WALL VENT APPLICATION

When installed as a rear vent unit this appliance may be vented directly to a termination located on the rear wall behind the appliance.

- Only Vermont Castings Group approved venting components are approved to be used in these applications (Refer to 'Venting Components' listed for different installation requirements).
- The maximum horizontal distance between the rear of the appliance (or end of the transition elbow in a corner application) and the outside face of the rear wall is 20" (508 mm). *Figure 14*
- Only one 45° elbow is allowed in these installations.
- Minimum clearances between vent pipe and combustible materials are as follows:
 Top - 3" (76 mm)
 - except at outside wall 1" (25 mm)
 Sides - 1" (25 mm)
 Bottom - 1" (25 mm)

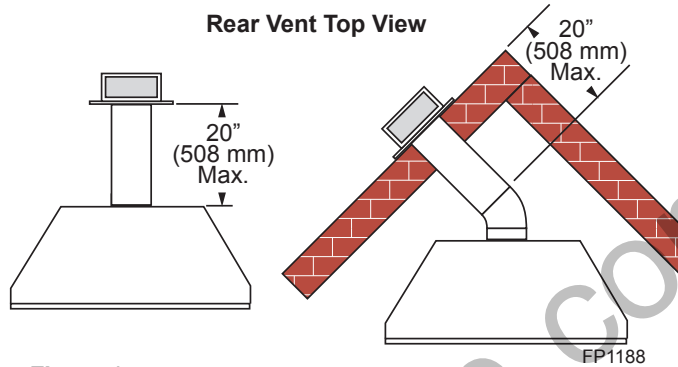

Figure 15 -
Rear Vent Application, No Elbows

REAR WALL VENT INSTALLATION - TWIST LOCK PIPE

Step 1

Locate and cut the vent opening in the wall. For combustible walls first frame in opening. *Figure 16*
NOTE: When using flex vent, the opening will have to be measured according to the 1" (25 mm) rise in 24" (610 mm) vertical run.

Combustible Walls: Cut a 9⁵/₈"H x 9⁵/₈" W (244 x 244 mm) hole through the exterior wall and frame as shown. *Figure 16*

Noncombustible Walls: Hole opening should be 7¹/₂" (191 mm) diameter.

Vent Opening for Combustible Walls

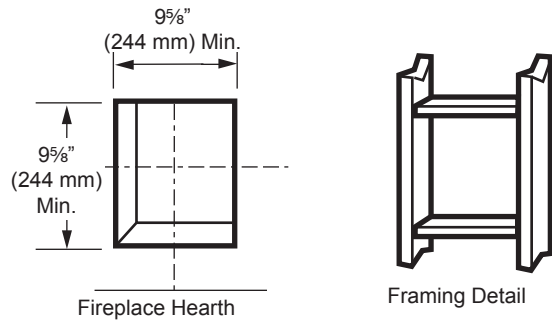

Opening for Noncombustible Wall

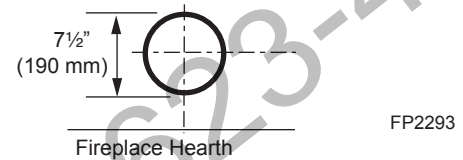

Figure 16 -
Locate vent opening on wall

Step 2

Secure firestop to the inside frame, center in the 9⁵/₈" x 9⁵/₈" vent opening.

Step 3

Measure the horizontal length requirement for the venting including a 2" (51 mm) overlap, i.e. from the elbow to the outside wall face plus 2" (51 mm). *Figure 15*

Step 4

Install the 4" (102 mm) vent to the appliance collar and secure with 3 sheet metal screws. Install the 7" (178 mm) vent pipe to the appliance collar and secure with 3 sheet metal screws. It is not necessary to seal this connection. If a 45° elbow is being used attach the elbow to the appliance in the same manner then attach the venting to the elbow.



It is critical that there is no downward slope away from the appliance when connecting the vent or elbow.

Step 5

Guide the venting through the vent hole as you place the appliance in its installed position. Guide the 4" (102 mm) and 7" (178 mm) collar of the vent termination into the outer ends of the venting. Do not force the termination. If the vent pipes do not align with the termination, remove and realign the venting at the appliance flue collars. *Figure 17*. Attach the termination to the wall as outlined in the instruction sheet supplied with the termination.

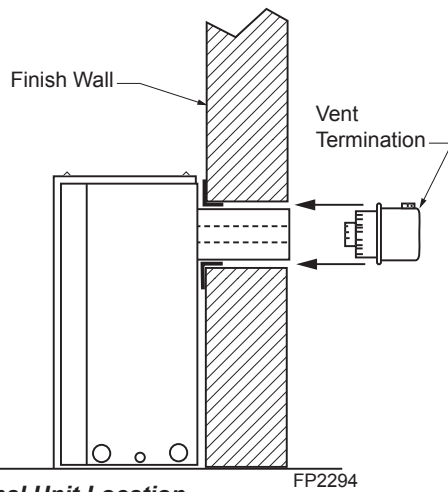

Figure 17 - Side View of Final Unit Location

REAR WALL VENT INSTALLATIONS - FLEX VENT PIPE

Follow Steps 1 and 2 on Page 19.

Step 3

Install the 4" (102 mm) flex vent pipe to the appliance collars described in "General Information Assembling Vent Pipes", Page 12. If the installation requires a 45° angle, grasp the vent pipe close to the appliance collar and bend to 45°. DO NOT exceed 45°. Figure 18

Install the 7" vent pipe in the same manner as Step 2.

NOTE: There must be a 1/2" (13 mm) rise in a 12" (305 mm) length of flex vent.

Step 4

Assemble the flex vent to the collars on the termination as you did on the appliance.

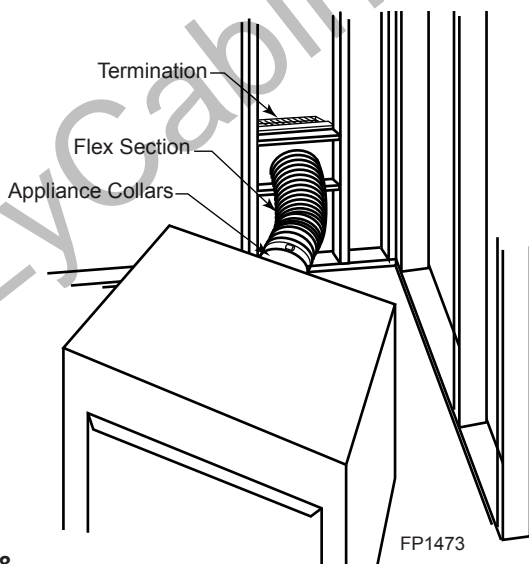

Figure 18 - Grasp the vent pipe close to the collar and bend to 45° angle. do not exceed 45°.

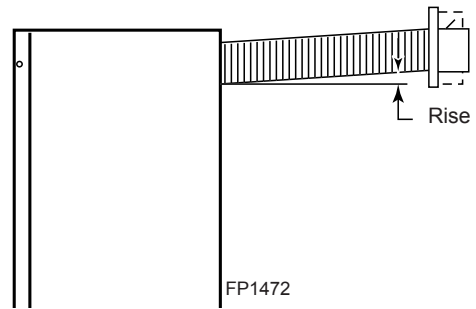

Figure 19 - There must be a 1/2" rise per foot length

TOP VENT SIDEWALL APPLICATION

NOTE: For all top vent installations where a 90° elbow is the first pipe piece towards a sidewall termination (up and out), an open-center ringed flue restrictor must be installed onto the top edge of the firebox flue adapter. To create this open-center restrictor, twist and break off the center rib of the supplied flue restrictor. The installed part should appear similar to that shown in Figure 20.

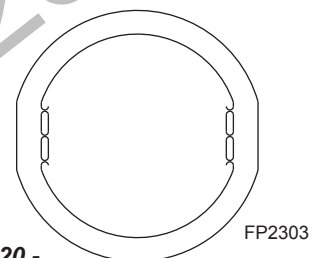

Figure 20 - Top Vent Vertical Sidewall Restrictor

Since it is very important that the venting system maintain its balance between the combustion air intake and the flue gas exhaust, certain limitations as to vent configurations apply and must be strictly adhered to.

The Vent Graph, showing the relationship between vertical and horizontal side wall venting, will help to determine the various dimensions allowable.

Minimum clearance between vent pipes and combustible materials is 3" (76 mm) on top, and 1" (25 mm) on the bottom and sides unless otherwise noted.

When vent termination exits through foundations less than 20" (508 mm) below siding outcrop, the vent pipe must flush up with the siding.

It is best to locate the fireplace in such a way that minimizes the number of offsets and horizontal vent length.

The horizontal vent run refers to the total length of vent pipe from the flue collar of the fireplace (or the top of the Transition Elbow) to the face of the outer wall.

Horizontal plane means no vertical rise exists on this portion of the vent assembly.

When installing the appliance as a rear vent unit, the 90° or 45° Transition Elbow attached directly to the rear of the unit is NOT INCLUDED in the following criteria and calculations, and unless specifically mentioned should be ignored when calculating venting layouts.

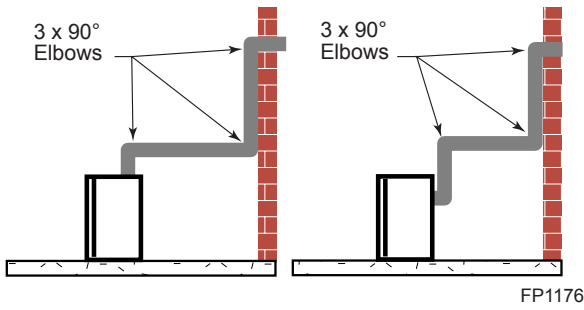

Figure 21 -
Maximum three (3) 90° elbows per installation

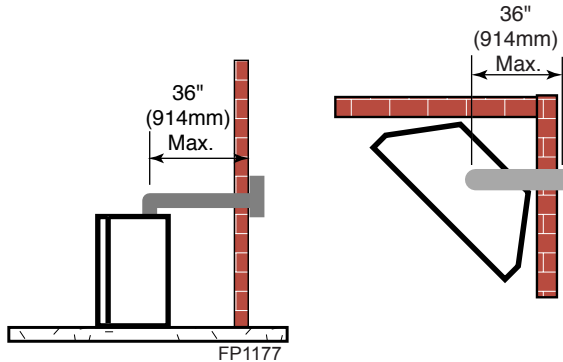

Figure 22 -
Maximum horizontal run with no rise

- The maximum number of 90° elbows per side wall installation is three (3). *Figure 21*
- If a 90° elbow is fitted directly on top of the fireplace flange the maximum horizontal vent run before the termination or a vertical rise is 36" (914 mm). *Figure 22*
- If a 90° elbow is used in the horizontal vent run (level height maintained) the horizontal vent length is reduced by 36" (914 mm). *Figures 22 & 23*. This does not apply if the 90° elbows are used to increase or redirect a vertical rise. *Figure 21*

Example: According to the vent graph (Page 15) the maximum horizontal vent length in a system with a 7½' (2.3 m) rise is 20' (6 m) and if a 90° elbow is required in the horizontal vent it must be reduced to 17' (5.2 m).

In *Figures 24 & 25*, dimension A plus B must not be greater than 17' (5.2m)

- The maximum number of 45° elbows permitted per installation is six (6). These elbows can be installed in either the vertical or horizontal run.
- For each 45° elbow installed in the horizontal run, the length of the horizontal run **MUST** be reduced by 18" (457 mm). This does not apply if the 45° elbows are installed on the vertical part of the vent system.
- The maximum number of elbow degrees in a system is 270°. *Figure 25*

Example: Elbow 1 = 90°
Elbow 2 = 45°
Elbow 3 = 45°
Elbow 4 = 90°

Total angular variation = 270°

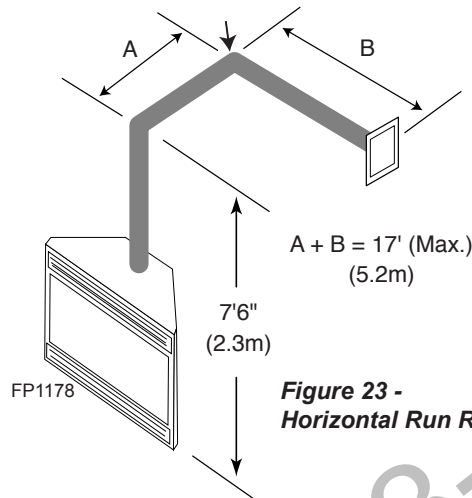

Figure 23 -
Horizontal Run Reduction

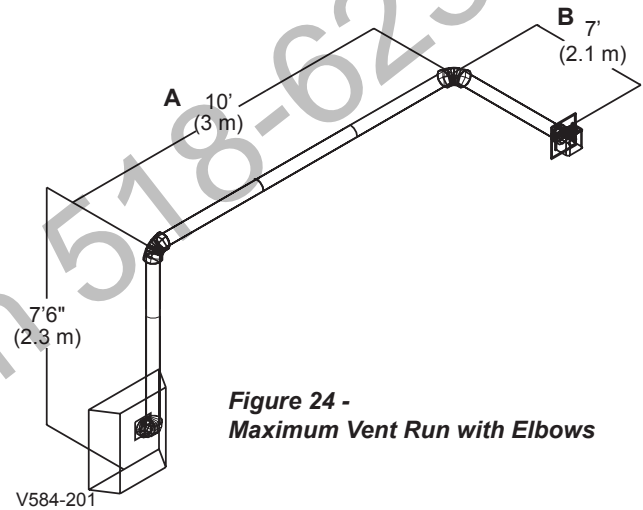

Figure 24 -
Maximum Vent Run with Elbows

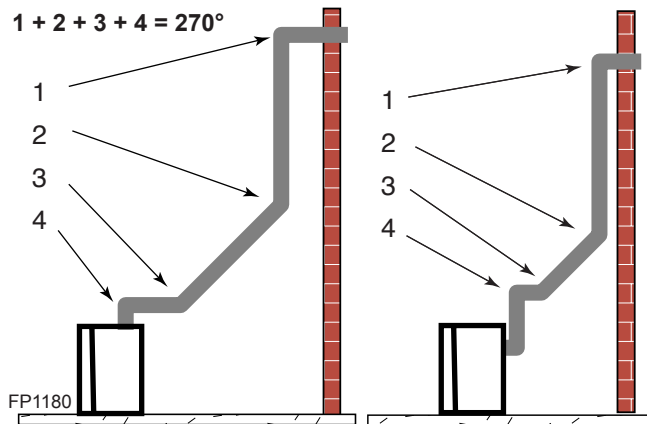

Figure 25 -
Maximum Elbow Usage

VERTICAL SIDEWALL INSTALLATION - TWIST LOCK PIPE

Step 1

Locate vent opening on the wall. It may be necessary to first position the fireplace and measure to obtain hole location. Depending on whether the wall is combustible or noncombustible, cut opening to size. *Figure 26* (For combustible walls first frame in opening.)

NOTE: When using flex vent, the opening will have to be measured according to the 1/2" (13 mm) rise in 12" (305 mm) vent run.

Combustible Walls: Cut a 9 5/8" H x 9 5/8" W (244 x 244 mm) hole through the exterior wall and frame as shown. *Figure 26*

Noncombustible Walls: Hole opening must be 7 1/2" (191 mm) in diameter.

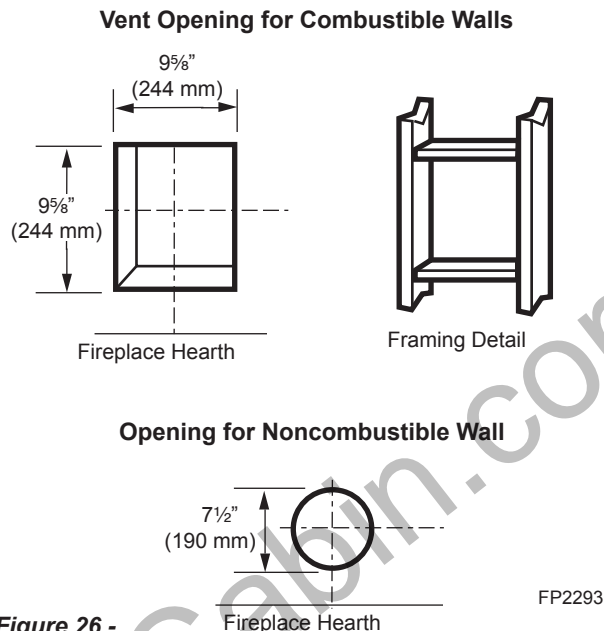

Figure 26 - Locate Vent Opening on Wall

Step 2

Secure firestop to the inside frame, center in the 9 5/8" x 9 5/8" vent opening.

Step 3

Place fireplace into position. Measure the vertical height (X) required from the base of the flue collars to the center of the wall opening. *Figure 27*

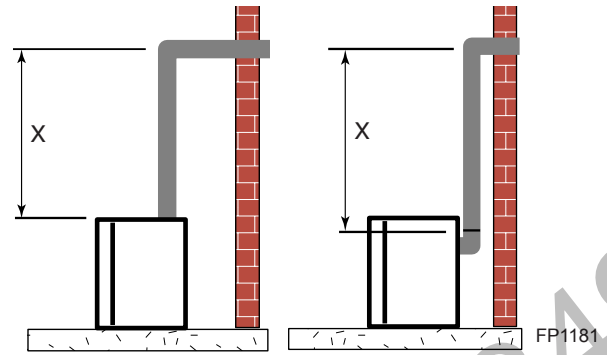

Figure 27 - Vertical Height Requirements

Step 4

Using appropriate length of pipe section(s) attach to fireplace with three (3) screws. Follow with the installation of the inner and outer elbow, again secure joints with three (3) sheet metal screws.

Step 5

Measure the horizontal length requirement including a 2" (51 mm) overlap, i.e. from the elbow to the outside wall face plus 2" (51 mm) (or the distance required if installing a second 90° elbow). *Figure 28*



Always install horizontal venting on a level plane.

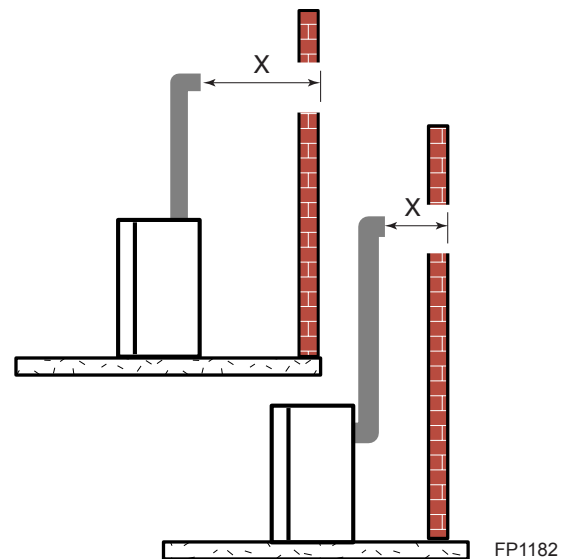

Figure 28 - Horizontal Length Requirement

Step 6

Use appropriate length of pipe sections - telescopic or fixed - and install. The sections which go through the wall are packaged with the starter kit, and can be cut to suit if necessary.

Step 7

Guide the vent terminations 4" and 7" collar into their respective vent pipes. Double check that the vent pipes overlap the collars by 2" (51 mm). Secure the termination to the wall with screws provided and caulk around the wall plate to weatherproof. As an alternative to screwing the termination directly to the wall, you may also use expanding plugs or an approved exterior construction adhesive. You may also attach the termination with screws through the inner body into the 4" vent pipe, however for this method, you must extend the 4" pipe approximately 6" (152 mm) beyond the outer face of the wall.



Support horizontal pipes every 36" (914 mm) with metal pipe straps.

VERTICAL SIDEWALL INSTALLATION - FLEX VENT PIPE

NOTE: The 40" (1016 mm) flex vent is used for 90° off the top of the unit then out the back wall. Follow Step 1 and 2 on Page 22.

Step 3

Install the four (4) spacer springs on the 4" flex vent pipe. When installing the spacer springs around the 4" pipe, stretch the spring to approximately 15" (381 mm), wrap the spring around the pipe and interlock the ends of the spacer spring approximately 2" (51 mm). Measure 6¾" (172 mm) from the end of the pipe. Place the next spring 5" (127 mm) from the previously installed spring. Place the next spring 6" (152 mm) from the last spring. Finally place the last spring 12" (305 mm) from the last spring installed. *Figure 29*

Step 4

Install the 4" (102 mm) flex vent pipe to the appliance collar as described on Page 14. Secure the end with the first spring 6¾" (172 mm) from the flex pipe end to the unit.

Step 5

Slide the 7" (178 mm) flex vent pipe over the 4" flex vent pipe and secure the 7" collar as described on Page 14.

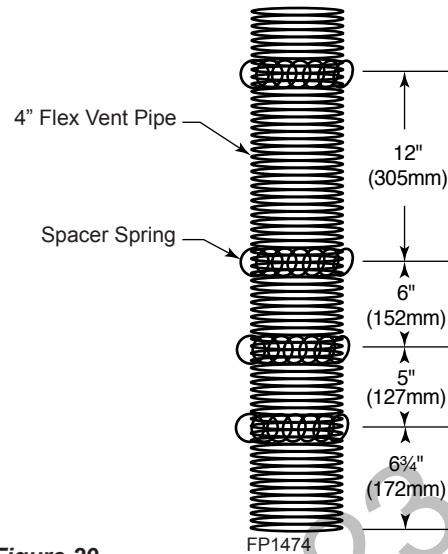

Figure 29 - Install Spacer Springs

Step 6

Bend the flex pipe horizontal so the bottom of the horizontal pipe measure 6½" (165 mm) from the top of the unit immediately after the 90° formation. *Figure 30*. Be sure to follow the 1/2" (13 mm) rise in a 12" (305 mm) horizontal run rule.

Step 7

Install the 4" flex then 7" flex to the termination.

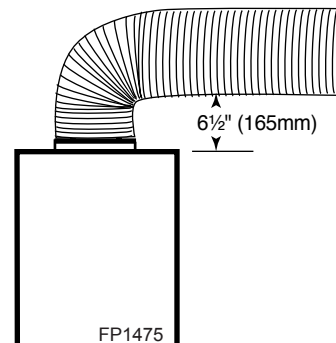

Figure 30 - Bend flex vent at 90° so horizontal portion is 6½" (165 mm) off top of unit

BELOW GRADE INSTALLATION

When it is not possible to meet the required vent terminal clearances of 12" (305 mm) above grade level, a snorkel kit is recommended. It allows installation depth down to 7" (178 mm) below grade level. The 7" (178 mm) is measured from the center of the horizontal vent pipe as it penetrates through the wall.

Ensure the sidewall venting clearances are observed. If venting system is installed below ground, we recommend a window well with adequate and proper drainage to be installed around the termination area.

If installing a snorkel, a minimum 24" (610 mm) vertical rise is necessary. The maximum horizontal run with the 24" vertical pipe is 36" (914 mm). This measurement is taken from the collar of the fireplace (or transition elbow) to the face of the exterior wall. See the Sidewall Venting Graph for extended horizontal run if the vertical exceeds 24" (610 mm).

1. Establish vent hole through the wall. *Page 22, Figure 26*
2. Remove soil to a depth of approximately 16" (406 mm) below base of snorkel. Install drain pipe. Install window well (not supplied). Refill hole with 12" (305 mm) of coarse gravel leaving a clearance of approximately 4" (102 mm) below snorkel. *Figure 31*
3. Install vent system.
4. Ensure a watertight seal is made around the vent pipe coming through the wall.
5. Apply high temperature sealant caulking (supplied) around the 4" and 7" snorkel collars.
6. Slide the snorkel into the vent pipes and secure to the wall.
7. Level the soil so as to maintain a 4" (102 mm) clearance below snorkel. *Figure 31*

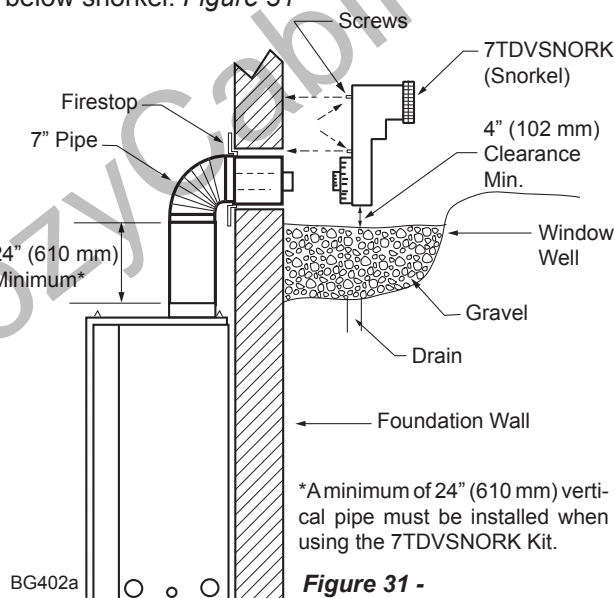

Figure 31 - Below Grade Installation



Do not back fill around snorkel.

A clearance of at least 4" must be maintained between the snorkel and the soil.

If the foundation is recessed, use recess brackets (not supplied) for securing lower portion of the snorkel. Fasten brackets to wall first, then secure to snorkel with self-drilling #8 x 1/2 sheet metal screws. It will be necessary to extend vent pipes out as far as the protruding wall face. *Figure 32*

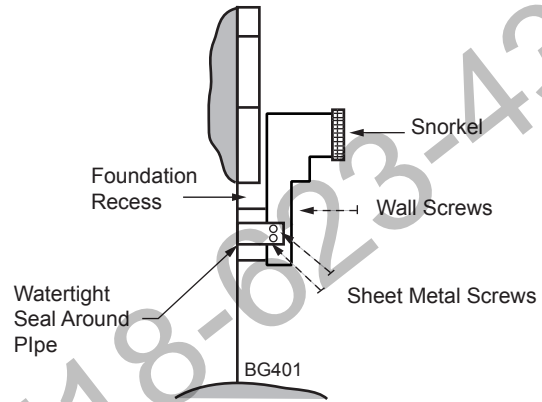

Figure 32 - Snorkel installation, recessed foundation

VERTICAL THROUGH-THE-ROOF APPLICATION

his gas fireplace has been approved for:

- Vertical installations up to 40' (12 m) in height. Up to a 10' (3 m) horizontal vent run can be installed within the vent system using a maximum of two 90° elbows. *Figure 33*
- Up to two 45° elbows may be used within the horizontal run. For each 45° elbow used on the horizontal plane, the maximum horizontal length must be reduced by 18" (450 mm).

Example: Maximum horizontal length:

- No elbows = 10' (3 m)
- 1 x 45° elbow = 8.5' (2.6 m)
- 2 x 45° elbows = 7' (2.1 m)

- A minimum of an 8' (2.5 m) vertical rise is required.
- Two sets of 45° elbow offsets may be used within the vertical sections. From 0 to a maximum of 8' (2.5 m) of vent pipe can be used between elbows. *Figure 33*
- 7DVCS supports offsets. *Figure 37*. This application will require that you first determine the roof pitch and use the appropriate starter kit. (Refer to Venting Components List)
- The maximum angular variation allowed in the system is 270°. *Figure 34*

- For the minimum height of the vent above the highest point of penetration through the roof refer to *Figure 38*, Page 26.

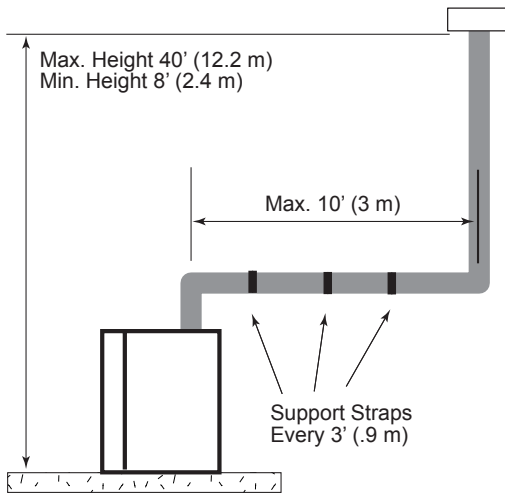

Figure 33 - Support Straps for Horizontal Runs

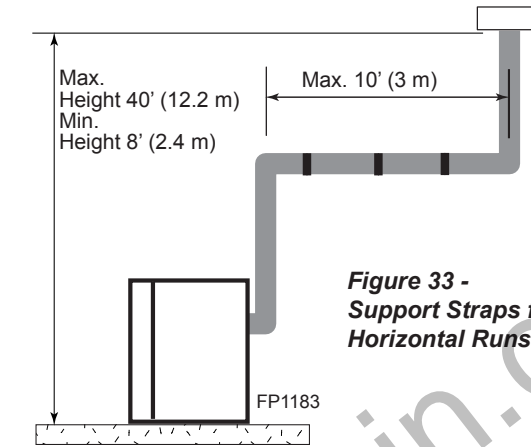

Figure 34 - Maximum Elbow Usage

VERTICAL THROUGH-THE-ROOF INSTALLATION

NOTE: For all top vent vertical through-the-roof installations, install the supplied cross-bar flue restrictor onto the top edge of the firebox flue adapter. *Figure 35*

1. Locate your fireplace.
2. Plumb to center of the (4") flue collar from ceiling above and mark position.
3. Cut opening equal to 9¾" x 9¾" (248 x 248 mm).
4. Proceed to plumb for additional openings through the roof. In all cases, the opening must provide a minimum of 1 inch clearance to the vent pipe, i.e., the hole must be at least 9¾" x 9¾" (248 x 248 mm).
5. Place fireplace into position.
6. Place firestop(s) or Attic Insulation Shield into position and secure. *Figure 36*

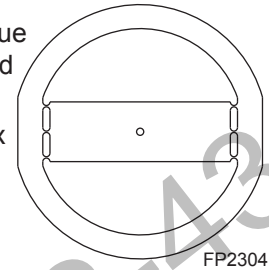

Figure 35 - Vertical Through-the-Roof Restrictor

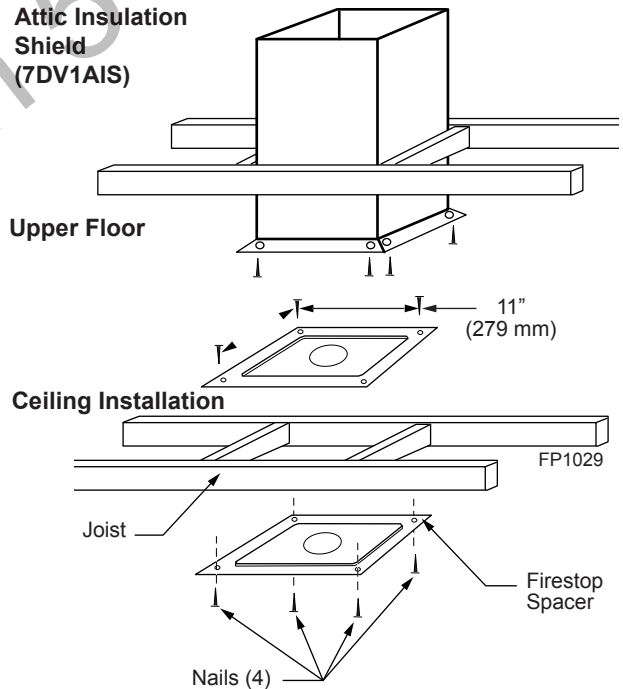
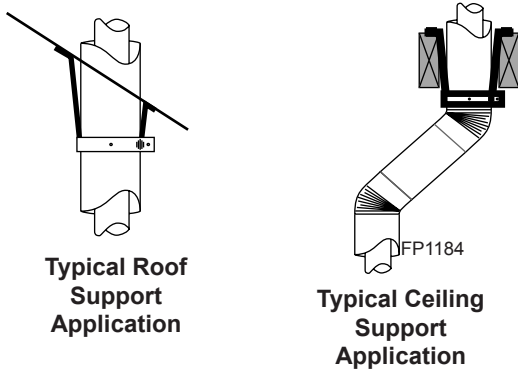

Figure 36 - Place Firestop Spacer(s) and Secure

7. Install roof support (*Figure 37*) and roof flashing making sure upper flange is below the shingles. *Figure 39*
8. Install appropriate pipe sections until the venting is above the flashing. *Figure 39*

9. Install storm collar and seal around the pipe.
10. Add additional vent lengths for proper height. *Figure 39*
11. Apply high temperature sealant to 4" and 7" collars of vertical vent termination and install.

If there is a room above ceiling level, fire stop spacer must be installed on both the bottom and the top side of the ceiling joists. If an attic is above ceiling level an Attic Insulation Shield must be installed. The enlarged ends of the vent section always face downward.



**Figure 37 -
Venting Supports**

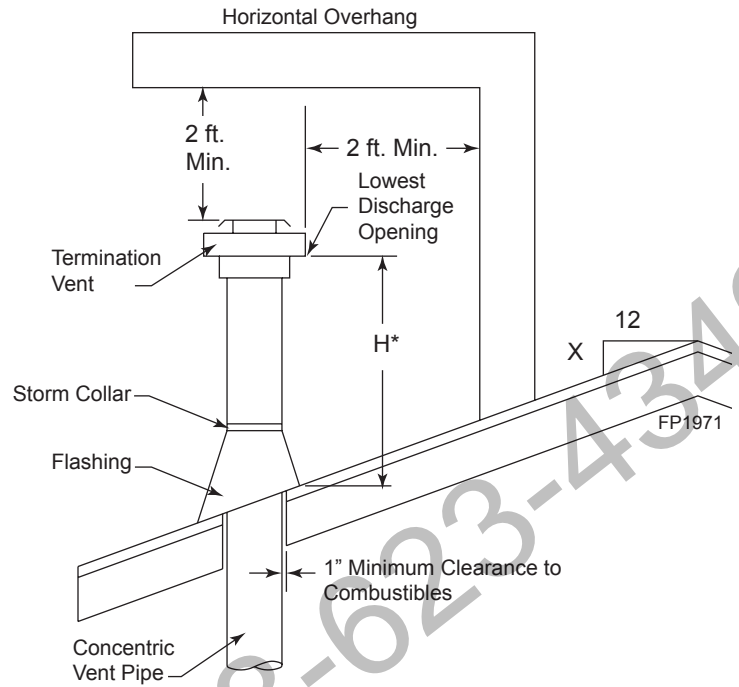

**Figure 38 -
Minimum Chimney Clearance**

| Roof Pitch | H (feet) |
|---------------------|----------|
| Flat to 6/12 | 1.0 |
| Over 6/12 to 7/12 | 1.25 |
| Over 7/12 to 8/12 | 1.5 |
| Over 8/12 to 9/12 | 2.0 |
| Over 9/12 to 10/12 | 2.5 |
| Over 10/12 to 11/12 | 3.25 |
| Over 11/12 to 12/12 | 4.0 |

*H - Minimum height from roof to lowest discharge opening of vent

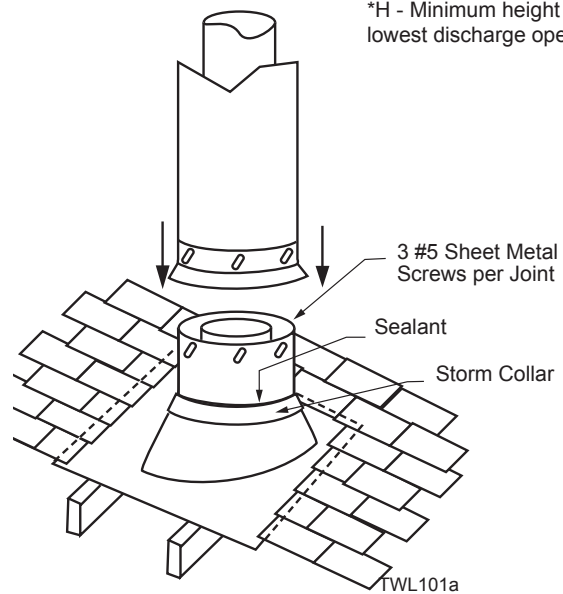

**Figure 39 -
Roof Flashing**

CHECK GAS TYPE

Use proper gas type for the fireplace you are installing. If you have conflicting gas type, do not install fireplace. See dealer where you purchased the fireplace for proper fireplace for your gas type or conversion kit.

INSTALL GAS PIPING TO FIREPLACE / BURNER SYSTEM LOCATION

WARNING A qualified installer or service person must connect appliance to gas supply. Follow all local codes.

INSTALLATION ITEMS NEEDED

Before installing fireplace and burner system, make sure you have the items listed below.

- External regulator
 - Piping (check local codes)
 - Equipment shutoff valve* • Test gauge connection*
 - Tee joint • Pipe wrench
 - Sediment trap (recommended)
 - Sealant (resistant to propane/LP gas) (supplied by installer)
 - approved flexible gas line with gas connector (if allowed by local codes — not provided)
- * A CSA design-certified equipment shutoff valve with 1/8" NPT tap is an acceptable alternative to test gauge connection. Purchase the CSA design-certified equipment shutoff valve from your dealer.

For propane/LP connections only, the installer must supply an external regulator. The external regulator will reduce incoming gas pressure. You must reduce incoming gas pressure to between 11 and 13 inches of water. If you do not reduce incoming gas pressure, burner system regulator damage could occur. Install external regulator with the vent pointing down as shown in *Figure 40*. Pointing the vent down protects it from freezing rain or sleet.

CAUTION For propane/LP units, never connect fireplace directly to the propane/LP supply. This burner system requires an external regulator (not supplied). Install the external regulator between the burner system and propane/LP supply.

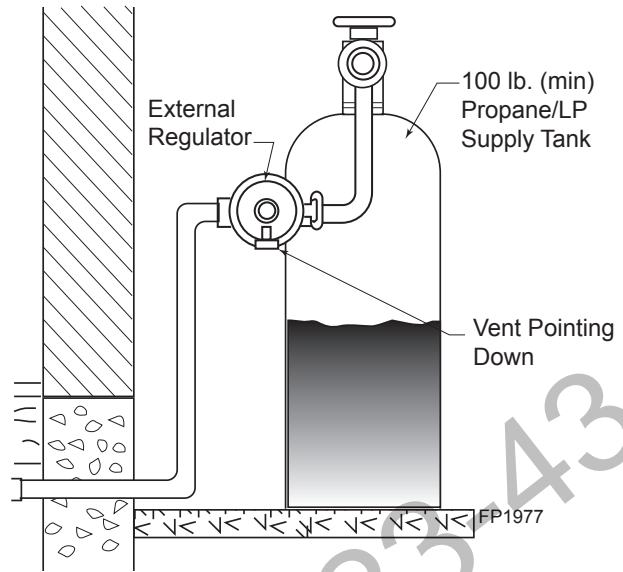

Figure 40 - External Regulator with Vent Pointing Down (Propane/LP Only)

CAUTION Use only new black iron or steel pipe. Internally tinned copper or copper tubing can be used per National Fuel Code, Section 2.6.3, providing gas meets hydrogen sulfide limits, and where permitted by local codes. Gas piping system must be sized to provide minimum inlet pressure (listed on data plate) at the maximum flow rate (BTU/hr). Undue pressure loss will occur if the pipe is too small.

When using copper or flex connectors use only fittings approved for gas connections. The gas control inlet is 3/8" NPT.

WARNING Only persons licensed to work with gas piping may make the necessary gas connections to this appliance.

CAUTION A manual shutoff valve must be installed upstream of the appliance. Union tee and plugged 1/8" NPT pressure tapping point should be installed upstream of the appliance. *Figure 41*

NOTE: The gas line connection may be made using 1/2" rigid tubing or an approved flex connector. Since some municipalities have additional local codes it is always best to consult your local authorities and the current edition of the National Fuel Gas Code ANSI.Z223.1, NFPA54. In Canada CSA-B149 (1 or 2) Installation Code.

A listed manual shutoff valve must be installed upstream of the appliance. Union tee and plugged 1/8" NPT pressure tapping point should be installed upstream of the appliance. *Figure 41*

IMPORTANT: Install main gas valve (equipment shutoff valve) in an accessible location. The main gas valve is for turning on or shutting off the gas to the fireplace.

Check your building codes for any special requirements for locating equipment shutoff valve to fireplaces.

Apply pipe joint sealant lightly to male threads. This will prevent excess sealant from going into pipe. Excess sealant in pipe could result in clogged burner system valve. We recommend that you install a sediment trap/drip leg in supply line as shown in *Figure 41*. Locate sediment trap/drip leg where it is within reach for cleaning. Install in piping system between fuel supply and burner system. Locate sediment trap/drip leg where trapped matter is not likely to freeze. A sediment trap collects moisture and contaminants and keeps them from going into the burner system gas controls. If sediment trap/drip leg is not installed or is installed wrong, burner system may not run properly.

CAUTION Use pipe joint sealant that is resistant to liquid petroleum (LP) gas.

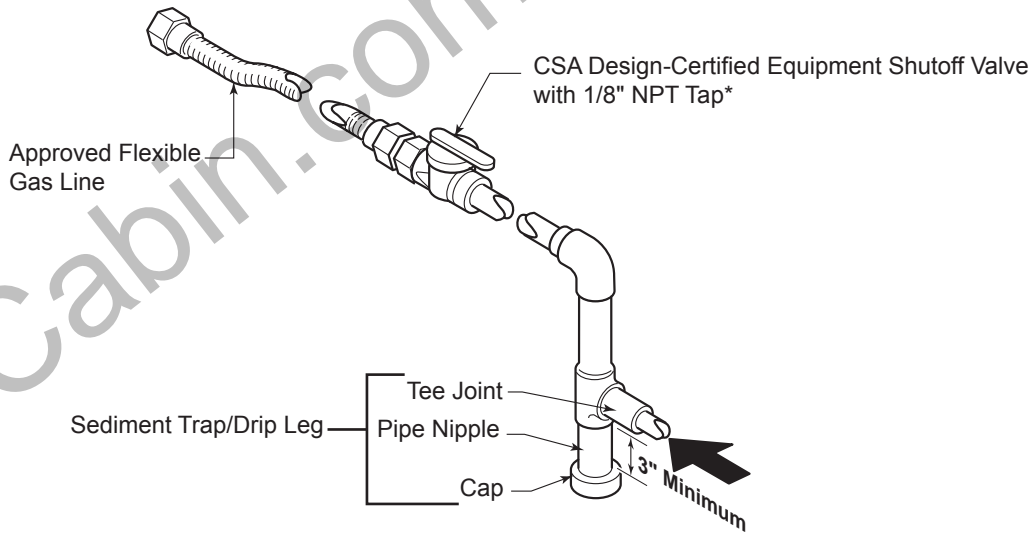
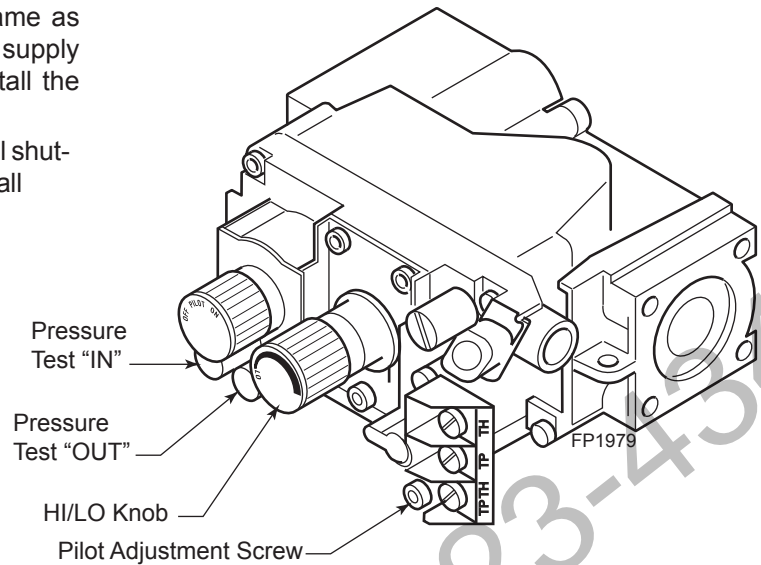

Figure 41 - Gas Connection

Natural Gas
From Gas Meter
(4.5" w.c. to 10.5" w.c. Pressure)
Propane/LP
From External Regulator
(11" w.c. to 13" w.c. Pressure)

1. Check gas type. The gas supply must be the same as stated on the appliance's rating decal. If the gas supply is different from the fireplace, **STOP!** Do not install the appliance. Contact your dealer immediately.
2. To ease installation, a 30" (mm) flex line with manual shut-off valve has been provided with this appliance. Install and attach 1/2" gas line onto shut-off valve.
3. After completing gas line connection, purge air from gas line and test all gas joints from the gas meter to the fireplace for leaks. Use a solution of 50/50 water and soap or a gas sniffer.
4. To adjust flame height, turn HI/LO knob to HI to get maximum pressure to burner. Turn HI/LO knob to LO to get minimum pressure.
5. To check gas pressures at valve, turn captured screw counter clockwise 2 or 3 turns and then place tubing to pressure gauge over test point. Turn unit to high. *Figure 42.* After taking pressure reading, be sure and turn captured screw clockwise firmly to reseal. Do not over torque. Check test points for gas leaks.



**Figure 42 -
Gas Pressure Check at Gas Valve**

ELECTRICAL WIRING

This fireplace will work without any electrical supply. Electricity is only needed to operate blower.

NOTE: If installed in mobile home, fireplace must be bolted securely to floor.

WARNING

Electrical connections should only be performed by a qualified, licensed electrician. Main power must be off when connecting to main electrical power supply or performing service. All wiring shall be in compliance with all local, city and state codes. The appliance, when installed, must be electrically grounded in accordance with local codes or in the absence of local codes, with the National Electrical Code ANSI/NFPA 70 (latest edition) and Canadian Electrical Code, CSA C22.1.

WARNING

Do not use open flame to check for gas leaks.

CAUTION

Label all wires before disconnecting when servicing controls. Wiring errors can cause improper and dangerous operation.

Verify proper operation after servicing.

REMOTE WALL MOUNTED SWITCH

A remote wall switch and up to fifteen (15) feet of 18 Ga. wire may be used with this appliance. Attach the wall switch in a junction box at the desired location on the wall. *Figure 43*. Do not extend beyond the wall switch wire length provided.

NOTE: Extended lengths of wire may cause the fireplace not to function properly. Longer length of wire is permitted if the wire is made out of larger gauge (diameter) wire. Always check with local code.

WARNING Do not connect wall switch to (110 V) circuit.

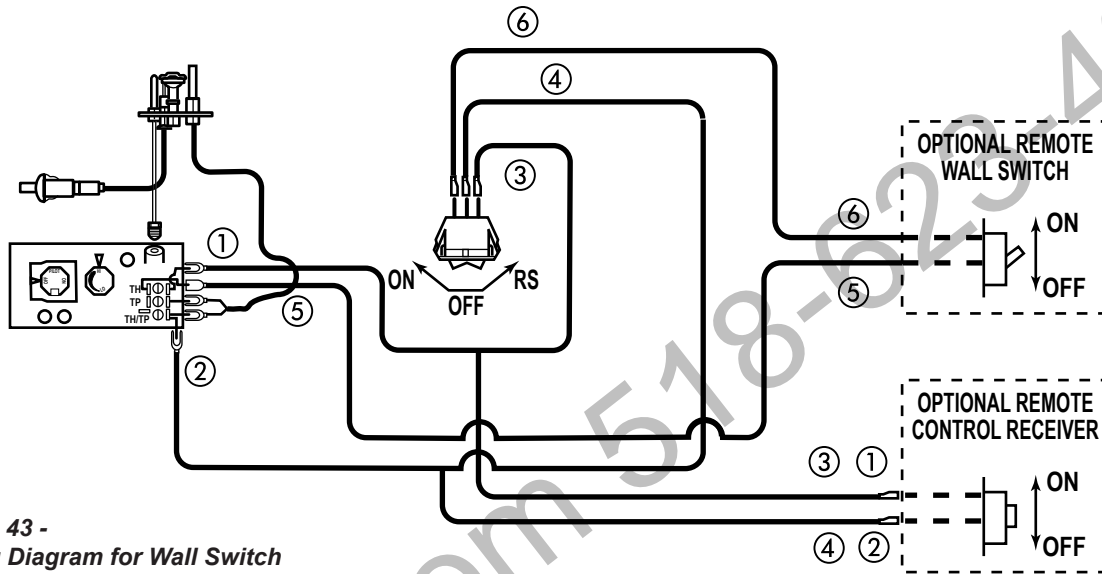

Figure 43 - Wiring Diagram for Wall Switch

FP1980

REMOTE WALL SWITCH

Position the wall switch. Do not extend beyond the 15 feet of wire.

OPTIONAL DC REMOTE SYSTEMS

See section entitled *Hearth Mount* in the Millivolt hand held remote instructions supplied with the remote.

1. Using a flat head screw driver, bend the "remote" tabs up from the bottom of the fireplace. *Figure 44*
2. Follow the instructions on remote control to snap the remote cover plate to the remote receiver
3. Connect the wire terminal from the remote receiver. *Figure 43*
4. Use the screws that came with the remote control to mount the remote receiver cover to the bent up "remote" tabs. *Figure 44*

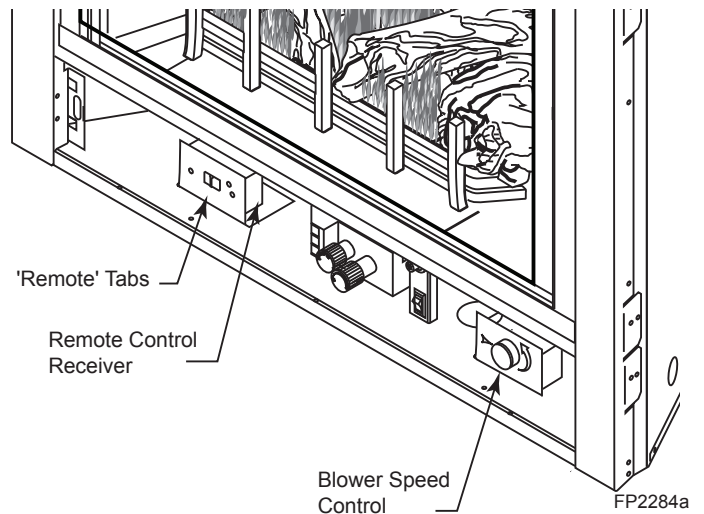

Figure 44 - Optional Control Location

ELECTRONIC PILOT IGNITION WIRING

WARNING

Do not connect 110-120 VAC to the Remote Wall Switch. The appliance will malfunction.

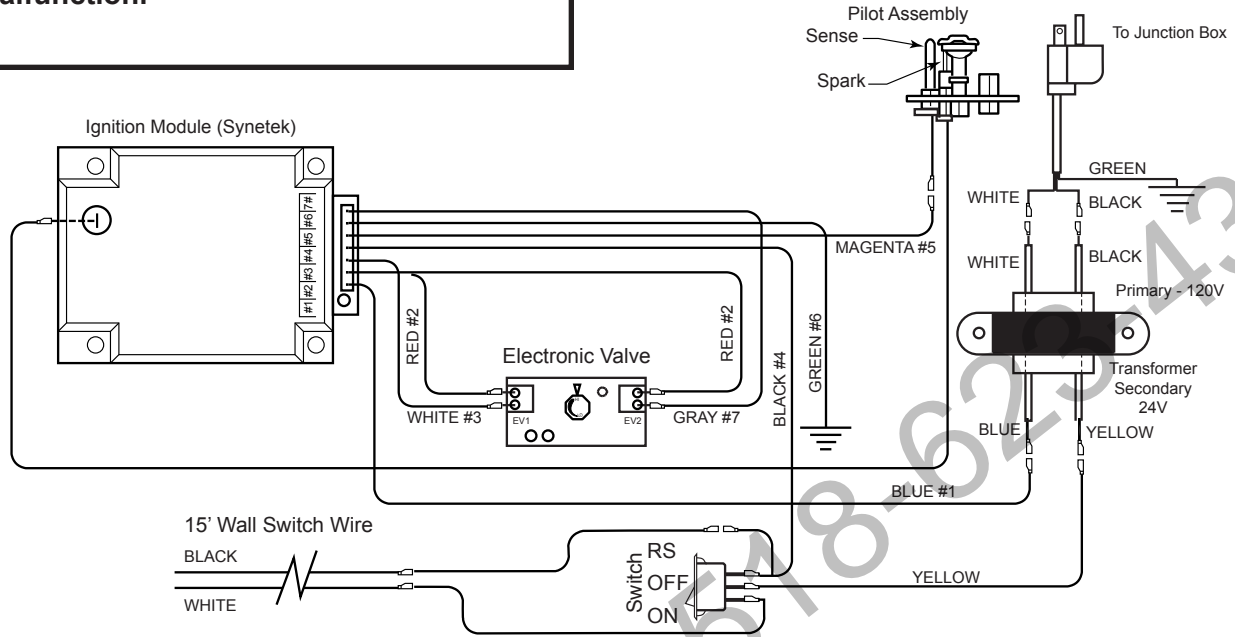

Figure 45 - Remote Wall Switch Wiring Diagram

OPTIONAL FAN/BLOWER SYSTEMS

The junction box for the fan/blower systems has been factory installed. This system requires that 110-120 VAC to be wired to the factory installed junction box before the fireplace is permanently installed.
Figure 46

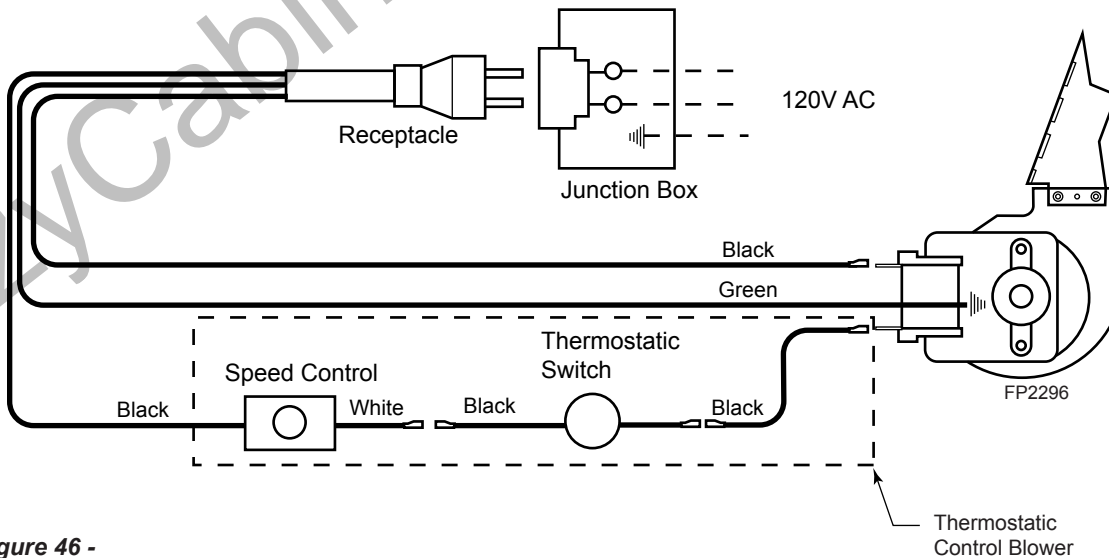

Figure 46 - Blower Wiring Diagram

FOR YOUR SAFETY READ BEFORE LIGHTING

WARNING

If you do not follow these instructions exactly, a fire or explosion may result causing property damage, personal injury or loss of life.

- A. This appliance is equipped with a pilot which must be lit with built-in piezo ignitor while following these instructions exactly.
- B. BEFORE OPERATING smell all around the appliance area for gas. Be sure to smell next to the floor because some gas is heavier than air and will settle on the floor.

WHAT TO DO IF YOU SMELL GAS:

- Turn off all gas to the appliance.
 - Open windows.
 - Do not attempt to light any appliance.
 - Do not touch any electric switch; do not use any phone in your building.
 - Immediately call your gas supplier from a neighbor's phone. Follow the gas supplier's instructions.
 - If you cannot reach your gas supplier, call the fire department.
- C. Use only your hand to push in, or turn the gas control knob. Never use tools. If the knob will not push in or turn by hand, don't try to repair it. Call a qualified service technician. Force or attempted repair may result in a fire or explosion.
 - D. Do not use this appliance if any part of it has been under water. Immediately call a qualified service technician to inspect the appliance and to replace any part of the control system and any gas control that has been under water.

LIGHTING PILOT FOR THE FIRST TIME

INITIAL LIGHTING

Purge air from the supply line as follows:

- Open main shutoff valve.
- Unscrew main pressure test point.
- Leave inlet test screw open until gas comes in.
- When gas is flowing, tighten inlet screw immediately.

LEAK TESTING

1. Follow the pipe from the gas supply line connection to the gas valve. Check connection for leaks with soap and water mixture.
2. Next check for gas leaks at the burner with soap and water mixture.
3. Check the pilot for gas leaks with soap and water mixture.

WARNING

Never use an open flame to check for gas leak.

LIGHTING PILOT FOR THE FIRST TIME

APPROVED LEAK TESTING METHOD

You may check for gas leaks with the following methods only:

- Soap and water solution
- An approved leak testing spray
- Electronic sniffer

DANGER

Never check for gas leak with open flame!

WARNING

If using a soap and water solution to test for leaks, **DO NOT** spray solution onto control body.

NOTE: Remove any excessive pipe compound from the connections. Excessive pipe compound can set off electronic sniffers.

Check for gas leaks in each of the following locations:

- Pipe from the gas supply line connection to the gas valve
- Burner connections
- Pilot
- Each joint or connection
- Field made joints / gas shutoff valve
- Factory made joints
- All joints on valve and control body

LIGHTING PILOT

WARNING

The control has an interlock device that does not allow the lighting of the fireplace up to the moment the safety device of the flame has not interrupted the gas flow. After that period of time (when the magnet is closed), it is possible to start the lighting operation.

The gas control knob is designed to be operated by hand. **DO NOT** use any tools during this operation. Damaged knobs may result in serious injury.

1. Depress and turn knob counterclockwise  to pilot position.
2. Depress fully and hold pilot gas knob. Depress piezo igniter as many times as needed to ignite pilot. Keep knob fully depressed for a few seconds. Release and check that pilot continues to burn.

If the pilot does not stay lit, repeat steps 1 and 2.

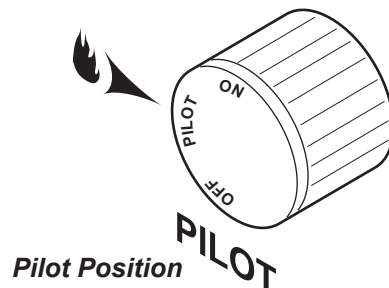

Continued on next page

LIGHTING BURNER

MAIN BURNER SWITCH

The "ON/OFF/RS" switch for the main burner can be found behind door of the fireplace. This switch allows you to turn on and to turn off the main burner without using the gas valve knob. Make sure the button is in the "ON" position to light the main burner.

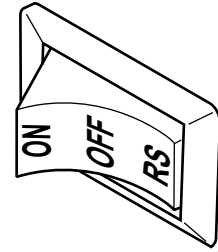

On/Off/RS Switch

LIGHTING THE BURNER

Depress and turn the knob counterclockwise ↶ to the "ON" position. It will take less than four (4) seconds for the burner to ignite.

PILOT POSITION

Depress and turn knob to pilot position to keep burner off while maintaining the pilot light.

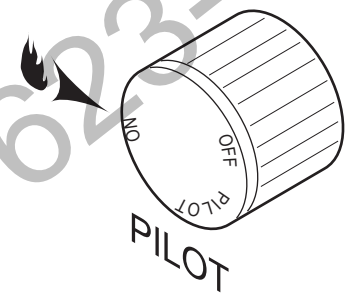

On Position

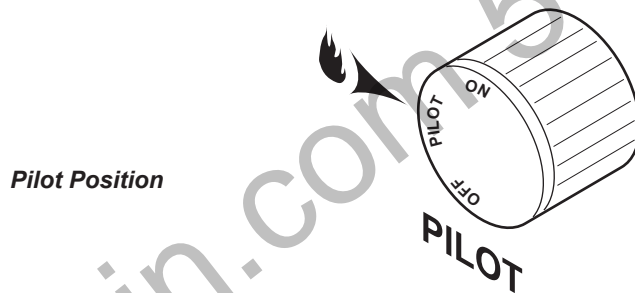

Pilot Position

TO TURN OFF GAS

Depress and turn knob clockwise ↷ to "OFF" position.

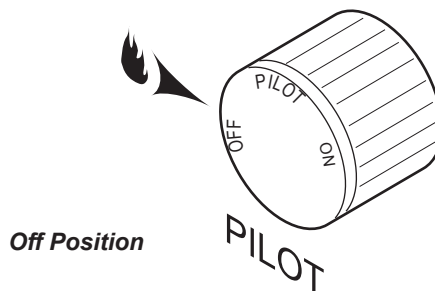

Off Position

FOR YOUR SAFETY READ BEFORE LIGHTING

- A.** This appliance is equipped with an ignition device (Piezo) which automatically lights the pilot. Do NOT try to light the burner by hand.
- B.** BEFORE OPERATING smell all around the appliance area for gas. Be sure to smell next to the floor because some gas is heavier than air and will settle on the floor.

WARNING

If you do not follow these instructions exactly, a fire or explosion may result causing property damage, personal injury or loss of life.

WHAT TO DO IF YOU SMELL GAS:

- Turn off all gas to the appliance.
 - Open windows.
 - Do not attempt to light any appliance.
 - Do not touch any electric switch; do not use any phone in your building.
 - Immediately call your gas supplier from a neighbor's phone. Follow the gas supplier's instructions.
 - If you cannot reach your gas supplier, call the fire department.
- C.** Turn off all electric power to appliance.
- D.** Do not use this appliance if any part of it has been under water. Immediately call a qualified service technician to inspect the appliance and to replace any part of the control system and any gas control that has been under water.

WARNING

Never use an open flame to check for gas leak.

LIGHTING ELECTRONIC IGNITION

1. **STOP!** Read the safety information above.
2. Make sure all power to unit is turned off.
3. Set thermostat to lowest setting.
4. This appliance is equipped with an ignition device which automatically lights the burner. Do not try to light the burner by hand.
5. Turn on all electric power to appliance.
6. Set thermostat to desired setting.
7. Turn RS-OFF-ON rocker switch to "ON".
8. If the appliance will not operate, follow the instruction *To Turn Off Gas* below and call your service technician or gas supplier.

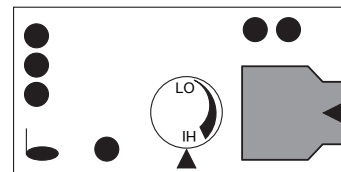

Electronic Gas Valve

TO TURN OFF GAS

1. Open lower door.
2. Turn RS-OFF_ON rocker switch to "OFF".
3. Turn off all electric power to the appliance if service is to be performed.
4. Close lower door.

SIGNATURE COMMAND - CHECK GAS PRESSURE and ELECTRICAL INSTALLATION

1. Check gas type. The gas supply must be the same as stated on the appliance's rating decal. If the gas supply is different from the fireplace, **STOP!** Do not install the appliance. Contact your dealer immediately.
2. To ease installation, a 24" (610 mm) flex line with manual shut-off valve has been provided with this appliance. Install and attach 1/2" gas line onto shut-off valve.
3. After completing gas line connection, purge air from gas line and test all gas joints from the gas meter to the fireplace for leaks. Use a solution of 50/50 water and soap solution or a gas sniffer.
4. To check gas pressures at valve, turn captured screw counter clockwise 2 or 3 turns and then place tubing to pressure gauge over test point. Turn unit to high. *Figure 47.* After taking pressure reading, be sure and turn captured screw clockwise firmly to reseal. Do not over torque. Check test points for gas leaks.

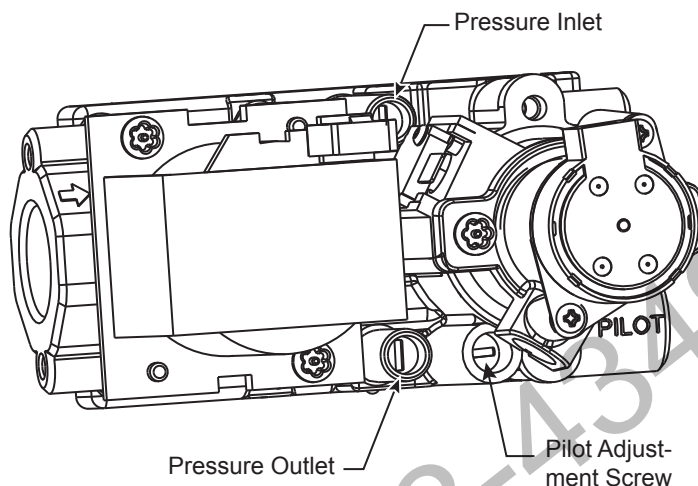

*Figure 47 -
Signature Command Valve*

WARNING

Do not use open flame to check for gas leaks.

ELECTRICAL WIRING

General

1. This fireplace is equipped with the Signature Control valve which operates on 6 volts. The 6 volt DC adapter plugs into the fireplace junction box A/C power supply. Four (4) "AA" batteries are used for back up during power outages.
2. The Signature Command System can also be operated without A/C power. The system can run on four (4) "AA" batteries for approximately six (6) months under normal use.
3. A/C power must be used to power the A/C module, blowers, lights and AUX accessories if used with this fireplace.

Optional Accessory Requirements

1. This fireplace may be used with a wall switch, wall mounted thermostat and/or Signature Command wireless controls.
2. The command center control may be mounted on the wall with the use of the SCSWEK 15ft. wall mount extension kit.

WARNING

Electrical connections should only be performed by a qualified, licensed electrician. Main power must be off when connecting to main electrical power supply or performing service. All wiring shall be in compliance with all local, city and state codes. The appliance, when installed, must be electrically grounded in accordance with local codes or in the absence of local codes, with the National Electrical Code ANSI/NFPA 70 (latest edition) and Canadian Electrical Code, CSA C22.1.

CAUTION

Label all wires before disconnecting when servicing controls. Wiring errors can cause improper and dangerous operation.

JUNCTION BOX WIRING

1. This should be done before framing the fireplace. Wire the receptacle into an electrical circuit. Wire with minimum 60° C wire in accordance with prevailing codes.
2. Remove the external junction box cover by removing the screw from the side of the outside firebox wall. Junction box was installed at the factory.
3. The junction box cover has a factory installed "romex" style strain relief connector. After connecting the wires, route the wire leads through this connector. Refer to the wiring diagram in *Figure 48*.

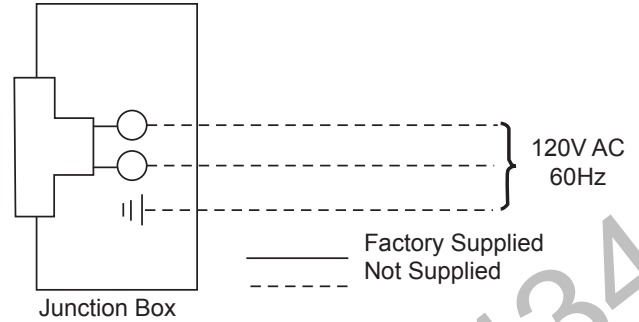

**Figure 48 -
Junction Box Wiring Diagram**

COMMAND CENTER WALL INSTALLATION

The command center may be mounted on the wall with the use of the SCSWEK Kit (15ft. cable, junction box, wall cover).

Mount the junction box provided at the desired location on the wall. Do not extend beyond the 15 ft. wire cable provided. If a longer distance is required, the 15 ft. may be extended up to 30 ft. maximum by using two (2) SCSWEK cables plugged together.

Route the wire from junction box to lower control area at bottom of fireplace. Unplug the 12" cable from the command center. Attach the connector to the pins from wire by pushing in to connector making sure to follow the color code on connector. Plug the 15 ft. extension cable into the 2 ft. cable. Remove command center from the fireplace and plug the other end of the extension cable into the command center. Snap on wall cover provided and screw to junction box.

WALL SWITCH INSTALLATION

The wall switch wire connection is located off the 2 ft. wire harness from the control box to the command center. *Figure 49*. The connection is labeled "Wall Switch". Unplug the male and female connectors and connect the two (2) low voltage wires provided. Run wire to desired location on wall. Up to 50 ft. of 18 ga. wire may be used if necessary. Attach wires to wall switch. Mount the wall switch in to junction box and screw on cover.

WARNING

Do not connect wall switch to 110 V circuit.

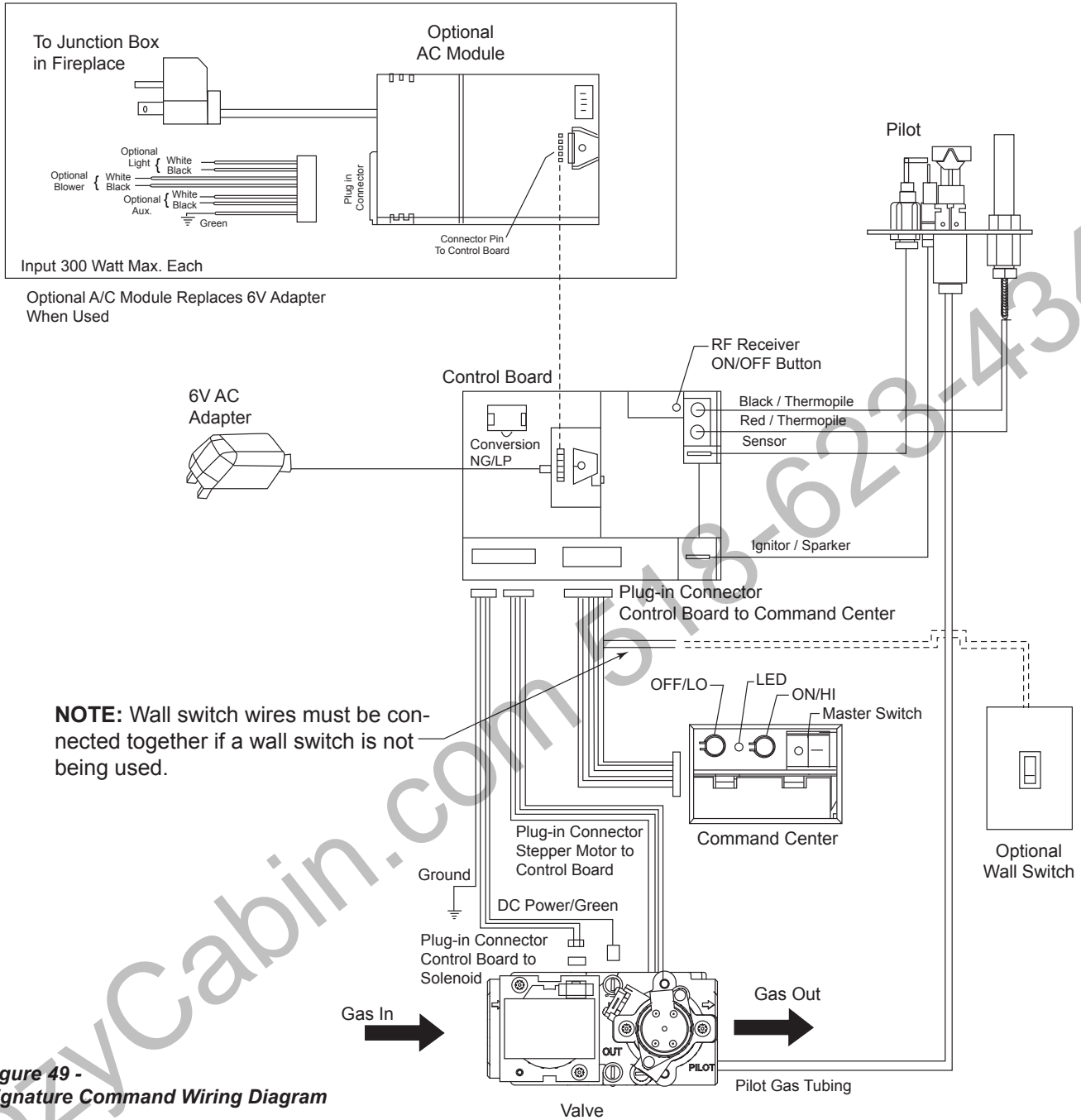

Figure 49 - Signature Command Wiring Diagram

CAUTION Electrical connections should only be performed by a qualified, licensed electrician. Main power supply must be turned off before connecting fans to the main electrical power supply or performing service.

WARNING Electrical Grounding Instructions: This appliance is equipped with a three-prong (grounding) plug for your protection against shock hazard and should be plugged directly into a properly grounded three-prong receptacle.

WARNING Electrical connections should only be performed by a qualified licensed electrician. Main power supply must be turned off before connecting the fan to the main electrical power supply or performing service.

NOTE The black and white wires on the AC box wiring harness are marked 'Blower', 'Light' and 'Aux'. It is important to use the wires marked 'Blower' or the control will not work correctly.

BLOTSC SIGNATURE COMMAND BLOWER

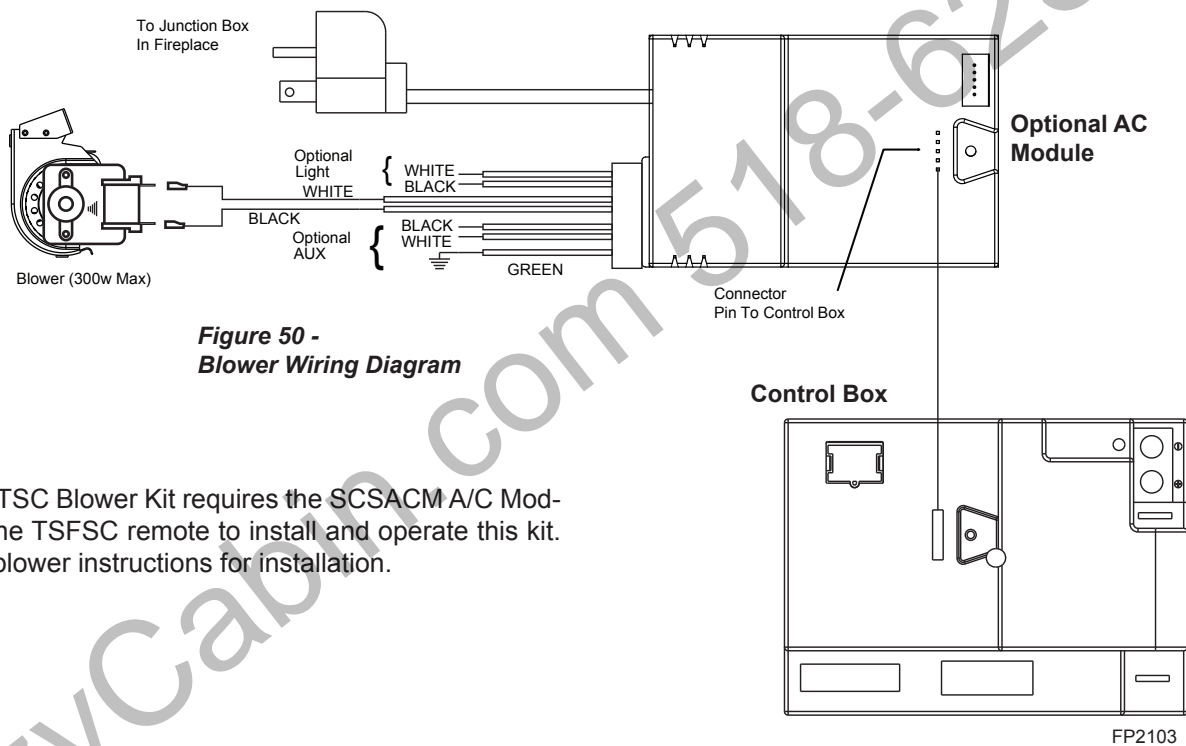

Figure 50 - Blower Wiring Diagram

The BLOTSC Blower Kit requires the SCSACM A/C Module and the TSFSC remote to install and operate this kit. Refer to blower instructions for installation.

BLOT AUTOMATIC THERMOSTAT BLOWER

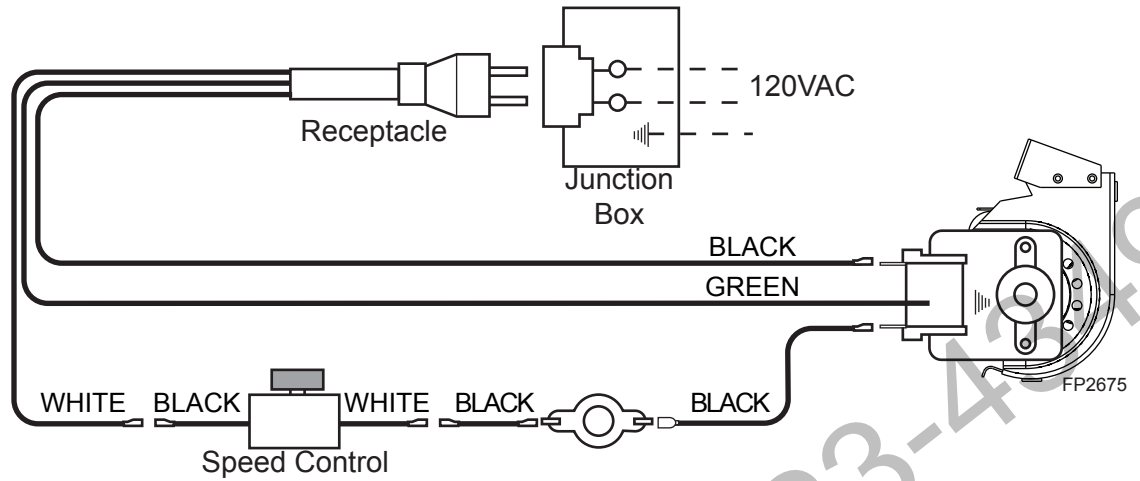

Figure 51 - BLOT Blower Wiring Diagram

Before installing the blower, wire the receptacle into an electrical circuit. This should be done before framing the fireplace. Wire with minimum 60° C wire in accordance with prevailing codes.

FK-12 MANUAL BLOWER

1. This must be done before framing the fireplace. When installing the FK-12 blower, a wall switch control must be installed to control the blower.
2. The fireplace power supply is wired through the blower wall switch and then brought to the fireplace junction box.
3. The jumper clip on the plug receptacle must be removed. *Figure 52.* Use needlenose pliers to break off the jumper clip.

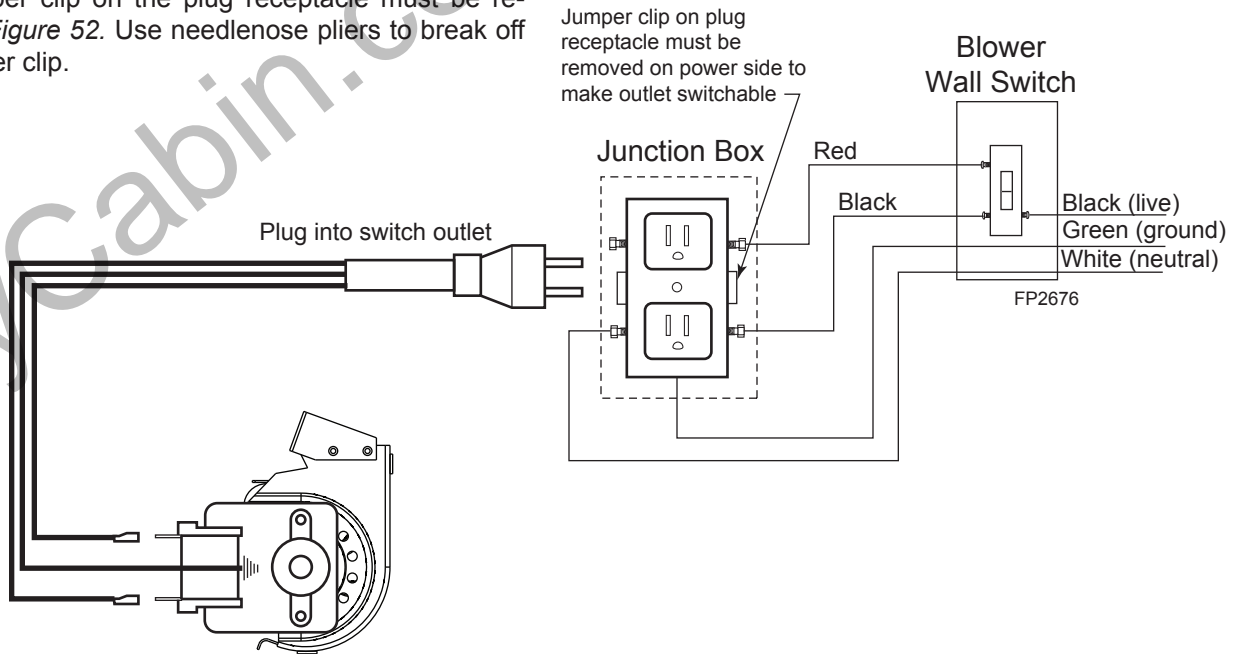

Figure 52 - FK-12 Blower wiring Diagram

FOR YOUR SAFETY READ BEFORE LIGHTING**WARNING**

If you do not follow these instructions exactly, a fire or explosion may result causing property damage, personal injury or loss of life.

- A.** This appliance is equipped with an ignition device which automatically lights the pilot. Refer to the instructions.
- B.** BEFORE OPERATING smell all around the appliance area for gas. Be sure to smell next to the floor because some gas is heavier than air and will settle on the floor.

WHAT TO DO IF YOU SMELL GAS:

- Do not attempt to light any appliance.
 - Do not touch any electric switch; do not use any phone in your building.
 - Immediately call your gas supplier from a neighbor's phone. Follow the gas supplier's instructions.
 - If you cannot reach your gas supplier, call the fire department.
- C.** Use only your finger to push in the master switch. Never use tools. If the switch will not function by hand, do not try to repair it. Call a qualified service technician. Force or attempted repair may result in a fire or explosion.
- D.** Do not use this appliance if any part of it has been under water. Immediately call a qualified service technician to inspect the appliance and to replace any part of the control system and any gas control that has been under water.

OPERATING INSTRUCTIONS

1. **STOP!** Read the safety information above.
2. This appliance is equipped with an ignition device which automatically lights the burner. Do not try to light the burner by hand.
3. Wait five (5) minutes to clear out any gas. Then smell for gas, including near the floor. If you smell gas, **STOP!** Follow "B" in the safety information on page 41. If you do not smell gas, go to next step.
4. Press the master switch to the "ON" (-) position. Within eight (8) seconds it will beep once. This indicates the system is ready.
5. Press "ON " button. Sparker will spark and pilot flame will light.
6. Once pilot flame is established, the main burner flame will light automatically.
7. If the pilot will not stay lit after several tries, turn the master switch to "OFF" and call your service technician or gas supplier.

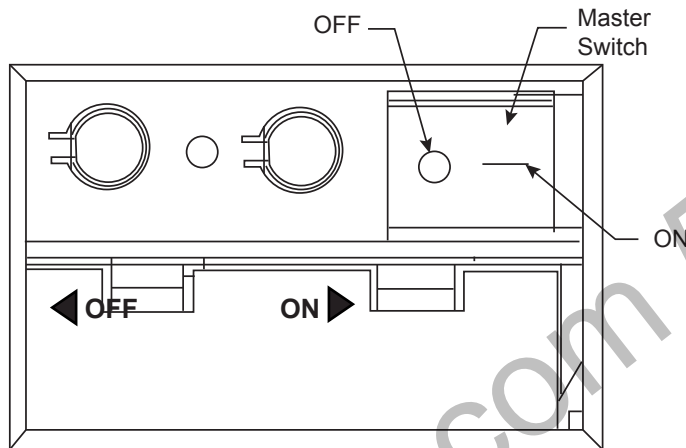

Command Center

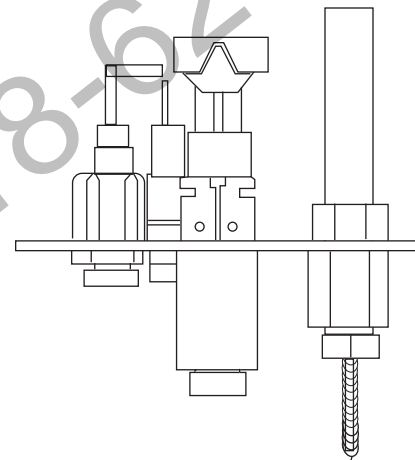

TO TURN OFF GAS TO APPLIANCE

1. Turn master switch to "OFF".
2. Turn off all electrical power to the appliance if service is to be performed.

FEATURES

Command Center

- Easy Access Function Operation and System Configuration
- Operation Confirmation/Fault Diagnostic Indications (LED/ Buzzer)
- ON/OFF/HI/Med/Low Operation
- Optional Wall Mounting

Control Board

- Electronic Ignition
- Pilot Lockout safety feature
- Electric Power Regeneration from Thermopile to save battery
- 6-hour Automatic Shut Down Option
- Convenient NG/LP Gas Type Conversion
- Standing Pilot/Intermittent pilot Conversion
- Previous settings Restoration Ability (Memory Off)
- Uninterrupted Operation During Power Outage (Automatic Battery Backup)
- ON/OFF RF Remote Receiver
- Optional Transmitter Learn Capability

AC Module Board (Optional, requires TSFSC Remote)

- Easy Snap-on Design
- Embedded Compact 120 VAC Adapter with Auto Battery Back up Feature
- Remote Controlled 3-step Blower, Lighting, and On/Off Auxiliary AC Outputs

Transmitter (Optional)

| | TSFSC | TSTSC | TSMSC | RMSC |
|---|-------|-------|-------|------|
| Three Flame Height Settings | X | X | X | X |
| Low battery Indication for Transmitter | X | X | X | X |
| Child Proof Lock-out | X | X | X | X |
| LCD Backlight | X | X | X | X |
| Security Codes 16 | X | X | X | X |
| Countdown 6 hr Timer | X | X | X | -- |
| Standard Thermostatic Control Mode | X | X | -- | -- |
| Smart Mode® Thermostat (Auto Flame & Blower Modulation) | X | X | -- | -- |
| Three Brightness Settings for Lights | X | -- | -- | -- |
| Three Speed Control for Blower | X | -- | -- | -- |
| On/Off Auxiliary | X | -- | -- | -- |
| Programmable Timer to turn blower on and off | X | -- | -- | -- |

BATTERY INSTALLATION

The Command Center uses four (4) "AA" batteries as back up for power outages. The system can operate for approximately six (6) months on battery power.

To Install Batteries (not included):

1. Press down the battery door tabs and pull out to remove battery door.
2. Install the batteries as indicated on Command Center.
3. Close battery door by snapping in place.
4. When the four (4) batteries are installed the system will operate without power.
5. The batteries should be replaced when the LED indicates low battery or at least once a year.

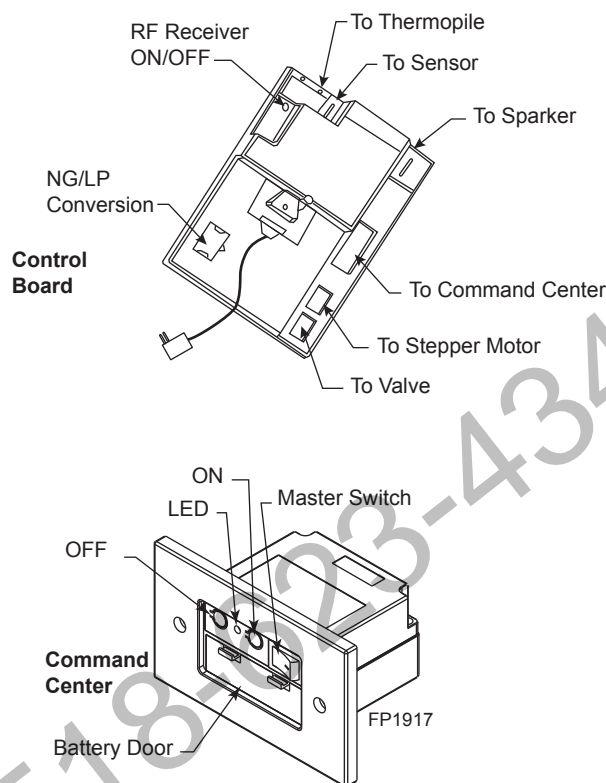

Figure 53 - Signature Command System Components

SIGNATURE COMMAND SYSTEM OPERATION INSTRUCTIONS

SYSTEM CONFIGURATION/SETUP

All System configuration/setup is done on the Command Center.

NOTE: When using On/Off wall switch, the switch must be in the ON position to perform all configuration set ups at the command center.

COLD CLIMATE OPTION

Choose the Mode That Best Suits Your Needs

The Signature Command System is designed to operate in either Standing Pilot or Intermittent Pilot mode.

- The Standing Pilot Mode is best for colder climates when the pilot must remain on continuously to prevent condensation and ensure reliable operation.
- The Intermittent Pilot Mode is ideal for maximum efficiency, igniting the pilot only when needed to start your fireplace, lowering fuel consumption and reducing your carbon footprint.

Either mode benefits from the instantaneous battery back-up, so you never have to worry about a power outage.

NOTE: The Signature Command System comes standard in the Intermittent Pilot mode, so you must follow the instructions below to switch to Standing Pilot Mode if needed.

Intermittent/Standing Pilot Setup (Default intermittent)

1. Holding the ON button on the Command Center while turning on the master switch will toggle between standing pilot and intermittent pilot.
2. After the above operation, one beep (for standing pilot) or two beeps (for intermittent pilot) will be given as confirmation.

Six-Hour Safety Shutdown Option (Default ON)

1. The system comes preset from the factory with a six (6) hour shutdown from its last command of operation. This is done to prevent the fireplace from continuing to operate if unattended. You may disable this feature if you wish.

NOTE: By disabling this feature, your fireplace may continue to operate unattended.

2. When the master switch is in the ON position (“-”), pressing the ON button and the OFF button on the Command Center simultaneously will toggle between enabling and disabling the six-hour shutdown option.
3. After the above operation, one beep (for enabling the six-hour shutdown option) or two beeps (for disabling the six-hour shutdown option) will be given as confirmation.

Remote Transmitter Learn Function (Default OFF)

1. The RF receiver button located on the Control Board must be in the on position before the learn function can begin. Use paper clip to depress button. One beep for RF receiver ON or two beeps for RF receiver OFF will be given as confirmation. Refer to Figure 60 for location.
2. After the RF receiver is on, holding the OFF button on the Command Center while turning on the master switch will activate the learn function for the transmitter.
3. After the above operation, two beeps will be given and the green LED on the Command Center will flash for 10 seconds.
4. During the 10 seconds, press the OFF button on a transmitter to learn. Another two beeps will be given to confirm a successful learning. Refer to transmitter instructions for remote operations.

Shutting Off the Standing Pilot (Temporary Shut Off)

To shut off the standing pilot for service or summer shutdown, press and hold the ON button on the Command Center for 3 seconds when the master switch is in the ON position (“-”) and the main burner is off.

Note: Pilot will resume the next time system is turned on.

Key Combinations for System Settings

NOTE: When On/Off wall switch is used, it must be in the On position to perform all system setups.

| Function | Operation | Default Setting |
|-----------------------------------|--|--------------------|
| Intermittent/Standing Pilot Setup | Hold the ON ▲ button while turning on the master switch (Beep once for standing pilot, twice for intermittent pilot) | Intermittent Pilot |
| Standing Pilot Temp. Shutoff | Hold the ON ▲ button 3 seconds (when the master switch on the main burner is off) | |
| RF Remote Receiver On/Off | Push the RF receiver On/Off button on the control board Beep once for ON and beep twice for OFF | RF OFF |
| Learn Remote Transmitter | Hold the OFF ▼ button while turning on the master switch (Beep twice then press any handheld remote button) | |
| 6-hour safety shutdown setup | Press the ON ▲ button and OFF ▼ button simultaneously (Beep once for ON, twice for OFF) | ON |

SIGNATURE COMMAND SYSTEM OPERATION INSTRUCTIONS

FUNCTIONS/OPERATION

Turning on the fireplace

1. Turn on the master switch and wait for a beep.
2. Press the ON button on the Command Center or turn on wall switch. Pilot will light and burner will come on High setting or last memory setting (See Turning Off Fireplace below). For memory feature.

Pilot Safety Lockout Function

1. If the pilot doesn't light after sparking for 30 seconds, pilot trial lockout happens. The LED on the Command Center flashes Green once every 2 seconds, until reset.
2. If the pilot flame is lost during normal operation, the system will try three (3) times to relight after three (3) failures, flame loss lockout happens. The LED on the Command Center flashes Red-Green once every 2 seconds, until reset.
3. Turning the master switch on the Command Center to the off position, then ON again will reset the system.

Flame Height Control

1. Press the ON button (on the Command Center) once to turn on the main burner with maximum flame height.
2. Press the OFF button to decrease flame height. The first two presses will decrease the flame height to medium and low.

3. The third press on OFF will turn off the main burner. In standing pilot configuration, the pilot will stay; in intermittent pilot configuration, the pilot will be shut off.

Turning the Fireplace Off

There are three ways to turn the fireplace off.

1. Flip the master switch to the off ("O") position. (This will turn the entire system OFF.)
2. Press the OFF button to Medium, Low, then Off.
3. Hold the OFF button anytime for three seconds or by turning off the wall switch. These two commands of OFF are (Memory Off) the system will remember all last settings before turning off. The next time the fireplace is turned on, all settings will resume. To reset, change to the desired settings and shut off by using the Memory Off commands and the system will be reset to those new settings.

Command Center Operations:

The following functions are available on the Command Center.

| Function | Operation |
|-------------------|--|
| Power Up | Flip the master switch to the ON ("I") position to power up the system |
| Fireplace ON | Press the ON ▲ button on the Command Center or turn on wall switch to turn the fireplace on |
| Fireplace OFF | Flip the master switch to the OFF ("O") position OR press the OFF ▼ button 3 times OR for Memory Off, hold the OFF ▼ button 3 seconds, or turn off wall switch |
| Flame Height Up | Press the ON ▲ button once to turn on the fireplace with maximum flame height |
| Flame Height Down | Press the OFF ▼ button to lower the flame height to Medium and Low |

Self Diagnostics Chart:

The Command Center has a self-diagnostic LED enabling you to troubleshoot problems and potentially avoid a service call. Please refer to the charts below for indicator reference.

| Fault | LED Indication |
|--|--|
| Conversion Cover Missing | One RED (1 time) |
| Spark Fail | Two RED (1 time) |
| No Sensor Signal | Three RED (1 time) |
| Pilot Lockout - trial | One GREEN, every 2 sec. (until manual reset) |
| Pilot Lockout - flame loss | One RED-GREEN, every 2 sec. (until manual reset) |
| Low Battery | One RED, every 10s (continuously) |
| No or Low Thermopile Power | Two RED, every 10s (continuously) |
| Learning | GREEN Flashes, every 1 sec. (for 10 sec.) |
| AC Power On | GREEN solid |
| Pressure Switch Failed (Power Vent only) | One RED every 2 sec. (until manual reset) |

GLASS FRAME REMOVAL

1. Remove upper and lower louvers.
2. Release the clamps on the bottom of the fireplace.
Figure 54
3. Tilt glass frame out and lift glass frame up until it clears the hook on top of the frame.
4. Set glass frame aside.

CAUTION Each clamp has a quick spring force. When reinstalling clamps, keep fingers clear.

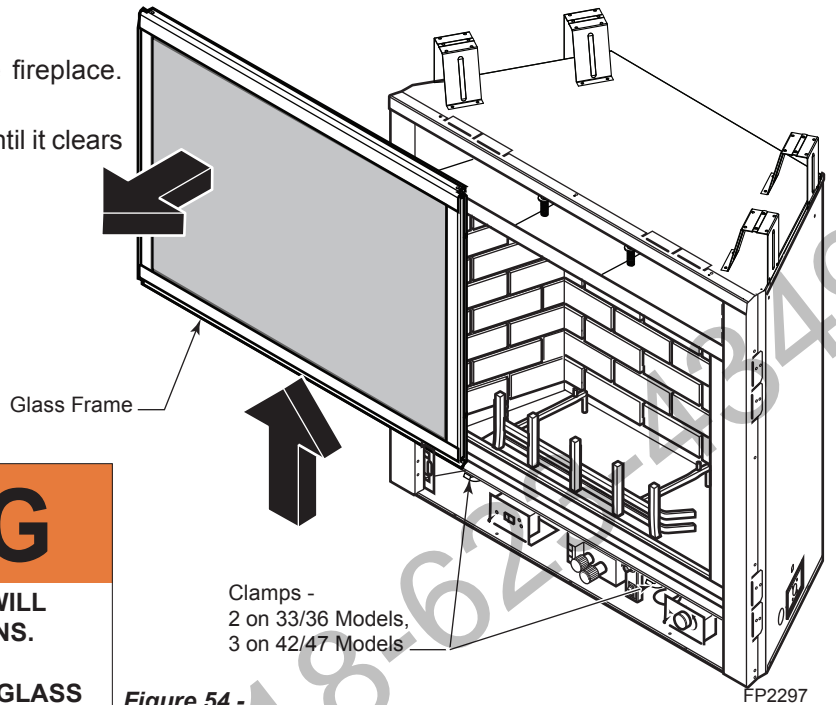

Figure 54 - Removing Glass Frame - CDVR Series Shown

WARNING

HOT GLASS WILL CAUSE BURNS.

DO NOT TOUCH GLASS UNTIL COOLED.

NEVER ALLOW CHILDREN TO TOUCH GLASS.

WARNING The use of too much rock wool could cause flame to burn poorly and may cause sooting.

NOTE: A mesh glass cover is available for this fireplace. This cover is recommended to reduce the severity of burns in case of accidental contact. Refer to the Accessories list on Page 55.

ROCK WOOL PLACEMENT

1. For best results in flame appearance and operation:
 - a. If your fireplace was supplied with three (3) 8-gram bags of rock wool embers: Use one (1) 8 gram bag or rock wool for propane/LP models and up to three (3) bags of rock wool for natural gas models depending on the size of your fireplace.
 - b. If your fireplace was supplied with one (1) 40-gram bag of rock wool embers: Use no more than 1/5 (8 grams) of the total amount of rock wool supplied in the 40 gram bag for propane/LP models and up to 3/4 of the 40 gram bag of rock wool for natural gas models depending on the size of your fireplace.

Use the following chart as a guide to how much rock wool to use:

| Models | Natural Gas | LP |
|--------------|---------------|---------------|
| CDV33, CDV36 | 24 grams max. | 8 grams max. |
| CDV42, CDV47 | 30 grams max. | 12 grams max. |

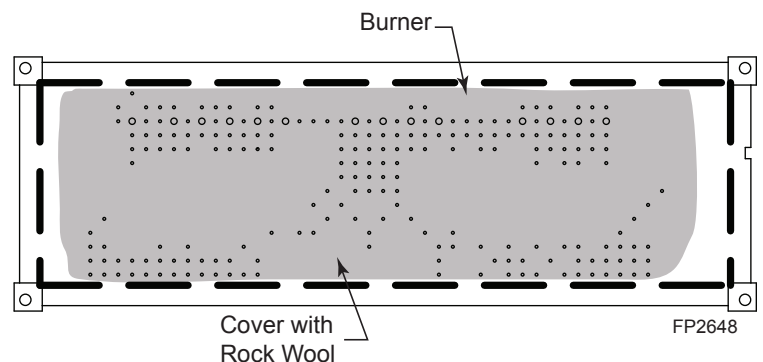

Figure 55 - Placement of Rock Wool on Burner

2. Pull the rock wool apart into dime-sized pieces or smaller. Cover the entire surface of the burner with one thin layer of rock wool.
3. Place the logs on the burner. Refer to the "Log Placement Section". Light the unit and after 15 minutes check burner flame and glow. Adjust embers as necessary to achieve an even and clean flame.

LOG PLACEMENT

Figure 56

1. Place rear log (#1) on grate assembly. Log should rest firmly on the two log mounting pins shown.
2. Place top right log (#2) on the rear log. Rest the right back side of the log in the flat area of the rear log. Place the narrow front end of the log next to the center vertical grate bar.
3. Place the top left log (#3) on the rear log. Nest the forked end of the top left log into the fork or the rear log. Rest the narrow end of the top left log behind the center vertical grate bar.

LAVA ROCK AND EMBER PLACEMENT

Sprinkle lava rock on the floor of the inner combustion chamber. Evenly distribute the rock. Do not pile the lava rock up in front of grate. Do not place lava rock on the burner. If desired, purchase optional embers to decorate the floor of the fireplace.

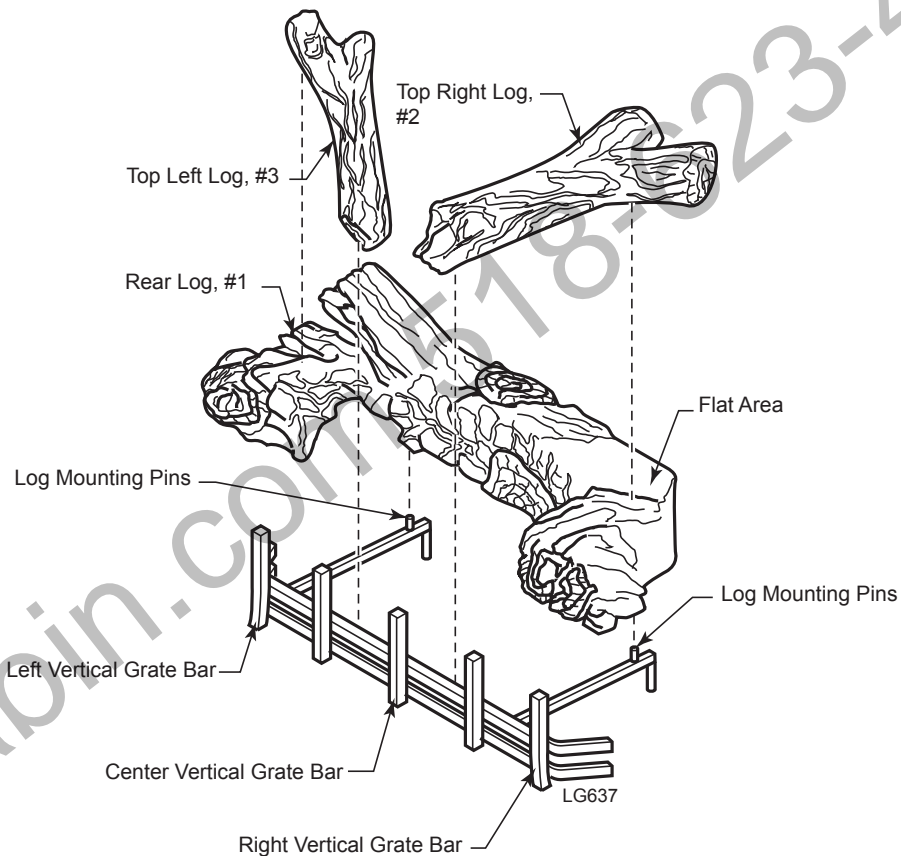

Figure 56 -
Log Placement

WARNING

Do not sprinkle the lava rock or ember chunks on top of the burner. This may cause potential sooting, glass breakage and a fire hazard

WARNING

Turn off gas before servicing fireplace. It is recommended that a qualified service technician perform these check-ups at the beginning of each heating season.

BURNER, PILOT AND CONTROL COMPARTMENT

Keep the control compartment, logs, and burner areas surrounding the logs clean by vacuuming or brushing at least twice a year. Make sure the burner porting, pilot air opening and burner air opening are free of obstructions at all times.

PILOT FLAME

The flames from the pilot should be visually checked as soon as the heater is installed and periodically during normal operation. **The pilot flame must always be present when the fireplace is in operation.** Figure 57. The pilot flame has three distinct flames, one engulfing the thermopile, one engulfing the thermocouple or sensor, and the other reaching to the main burner.

BURNER

Inspect area around the injector. Remove any lint or foreign material with a brush or vacuum.

BURNER FLAME

The flames from the burner should be visually checked as soon as the heater is installed and periodically during normal operation. In normal operation, at full rate, and after operating for about 15 to 30 minutes, the flame should be yellow and slightly taller than the rear log. Figure 58

If the flame is blue and only in the center, turn off unit and let cool. After unit is cool, remove logs and check to make sure rock wool is placed correctly. Replace logs.

NOTE: The type of installation, vent system configuration, and wind effects may cause the flame patterns to vary.

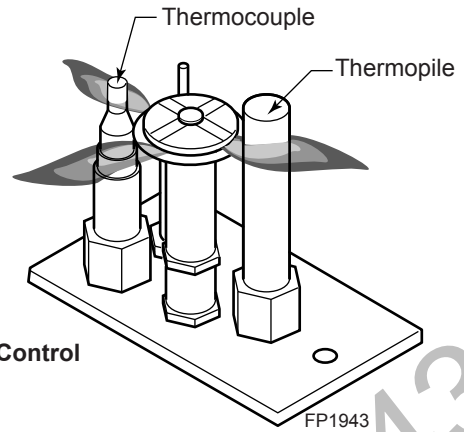

Millivolt Control Pilot

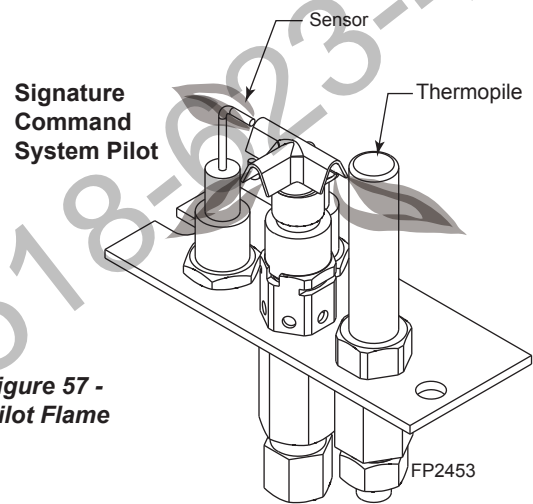

Figure 57 - Pilot Flame

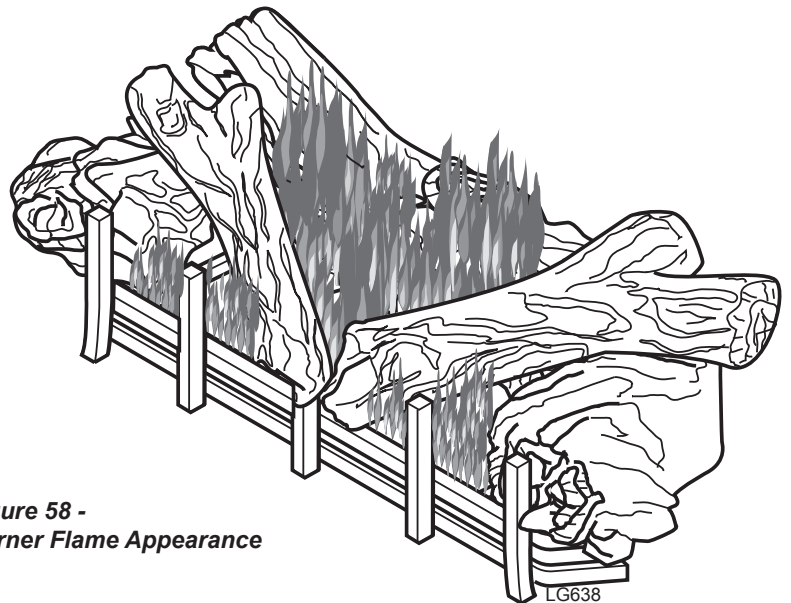

Figure 58 - Burner Flame Appearance

VENT SYSTEM

The fireplace and venting system should be inspected before initial use and at least annually by a qualified field service person. Inspect the external vent cap on a regular basis to make sure that no debris is interfering with the airflow. Inspect entire venting system to ensure proper function.

GLASS DOOR

Thoroughly clean the inside of the glass door after using the fireplace for ten hours. Periodically clean the glass door as necessary.

When cleaning the glass, remember:

- **Do not remove the glass when hot.** Allow glass to cool before removal.
- NEVER use abrasive materials.
- Keep children and pets a safe distance away.
- Never operate the fireplace without the glass door properly secured.
- Never operate the fireplace if the glass is broken.
- Replace any glass that is chipped, cracked, or broken. Replacement glass door assemblies **MUST** be supplied by the fireplace manufacturer – **No substitute materials may be used.**
- Handle glass door with care to avoid striking or scratching it on hard objects.

To clean glass door, follow “Glass Removal” procedure outlined in the *Final Installation* section. Film deposit on the inside of the glass should be cleaned off using a nontoxic, non-corrosive, non-abrasive, mild-cleaning solution. Simply apply an adequate amount to the glass and wipe off with a damp cloth. After all maintenance has been completed, re-install glass door.

LOGS

Leave logs installed in the fireplace for cleaning. Vacuum surface of the logs with a brush attachment. If logs must be removed for cleaning, handle carefully by holding gently at each end. Gloves are recommended to prevent skin irritation from ceramic fibers. If skin becomes irritated, wash gently with soap and water. Vacuum surface of logs with brush attachment or brush logs with a soft bristle brush (i.e. clean, dry paintbrush). To place logs back in the fireplace, Refer to “Log Placement” section in this manual.

NOTE: Do not use fluids to clean ceramic fiber logs.

ROCK WOOL

Replace or add rock wool as required following installation instructions in the *Final Installation* section of this manual.

STANDING PILOT IGNITION

| SYMPTOM | POSSIBLE CAUSE | ACTION |
|--|--|--|
| 1. Spark ignitor will not light pilot after repeated triggering of piezo. | A. Wire disconnected. | A. Open door and check to make sure wire is connected to ignitor. |
| | B. Defective ignitor. | B. Check for spark at electrode and pilot. If no spark and electrode wire is properly connected, replace pilot assembly. |
| | C. No gas or low gas pressure. | C. Check remote/manual shut off valve from fireplace. Low pressure can be caused by bent lines, restricted lines, low pressure line pressure. Consult with plumber or gas supplier. |
| | D. No Propane/LPG in tank | D. Check Propane/LPG tank. Refill tank. |
| 2. Pilot will not stay lit after carefully following lighting instructions. | A. Defective thermocouple | A. Check that thermocouple flame impinges on thermocouple. Clean and/or adjust pilot for maximum flame impingement. Ensure that the thermocouple connection at the gas valve is fully inserted and tight. Disconnect the thermocouple from the valve, place one millivolt lead wire on the tip of the thermocouple and the other meter lead wire on the thermocouple copper lead. Start the pilot and hold the valve knob in. If the millivolt reading is less than 15 mV, replace pilot assembly. |
| | B. Defective valve | B. If thermocouple is producing more than 15 mV, replace faulty valve. |
| 3. Pilot burning, valve knob turned to "ON", switch is turned to "ON" or "RS", but burner will not ignite. | A. Defective switch, wall switch, remote control or wire | A. Check switch and wire for proper connection. Place jumper wires across terminals of switch. If burner comes on, replace defective switch. If the switch is OK, repeat the same procedure on remote control. If burner comes on, replace remote control. Place jumper wire across wire at gas valves (terminals marked TH and TP/TH). If burner comes on, wires are faulty or connections are bad. Replace wire. |
| | B. Pilot flame too small | B. If pilot flame is not close enough to the thermopile, adjust pilot flame. |
| | C. Defective or malfunctioning thermopile | C. Check thermopile wire connections to make sure all are tight and that the thermopile is fully inserted into pilot assembly. Check thermopile with a millivolt meter. Connect leads to TP and TP/TH terminals on the control valve. If meter reading is below 325 mV, replace pilot assembly. |
| | D. Defective valve | D. Turn valve knob to "On" and switch to "ON." Take a reading at the thermopile leads (TP & TP/TH) on the valve. If the meter reads greater than 175 mV and the burner does not light, replace defective valve. |

STANDING PILOT IGNITION

| SYMPTOM | POSSIBLE CAUSE | ACTION |
|--|---|--|
| 4. Frequent pilot outage problem. | A. Pilot flame may be too high or too low, causing pilot safety to drop out | A. Clean and adjust the pilot flame for maximum flame impingement on thermocouple. |
| 5. The pilot and main burner extinguish while in operation | A. Inner vent pipe leaking exhaust gases back into system | A. Check for flue product leak. Replace defective pipe section. |
| | B. Horizontal vent improperly pitched | B. Check horizontal-venting piping is running upward 1/4" per foot. Do not run the pipe level or downward. |
| | C. Improper vent cap installation | C. Check for proper installation and freedom from debris or blockage. |
| 6. Glass Soots | A. Flame impingement on logs | A. Install log set per the instructions Inspect the injector and air intake area. Make sure this area does not have any blockage from debris and clean. Check gas supply. |
| 7. Flame burns blue and lifts off burner (ghosting) | A. Insufficient fresh air being supplied | A. Ensure that the vent cap is installed properly and free of debris. Ensure that the vent system joints are tight and have no leaks. Ensure that no debris has been blocking the inner air intake at the bottom back of the combustion chamber. Ensure that the glass is properly secure and latch. |

**ELECTRONIC IGNITION
START**

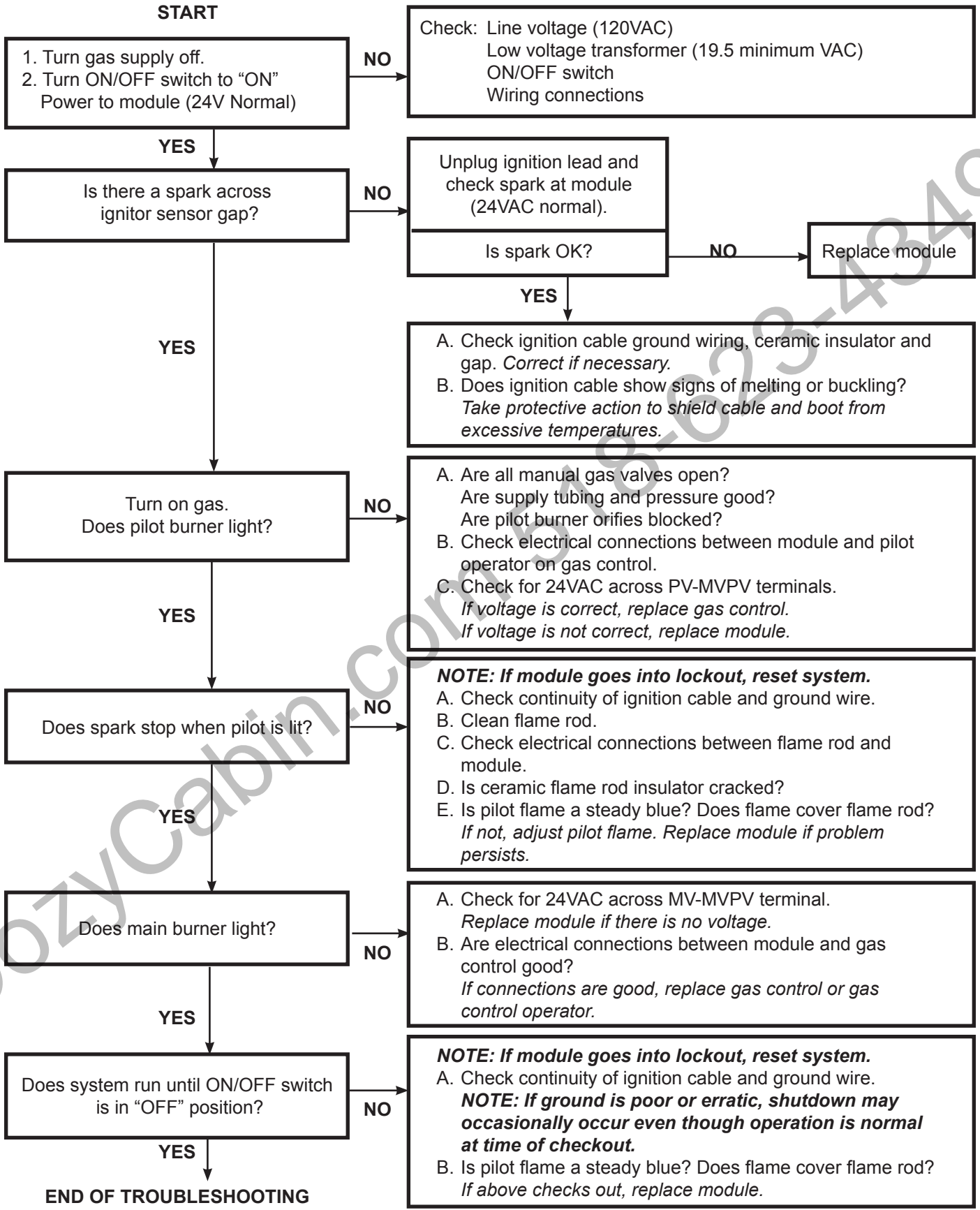

SIGNATURE COMMAND SYSTEM

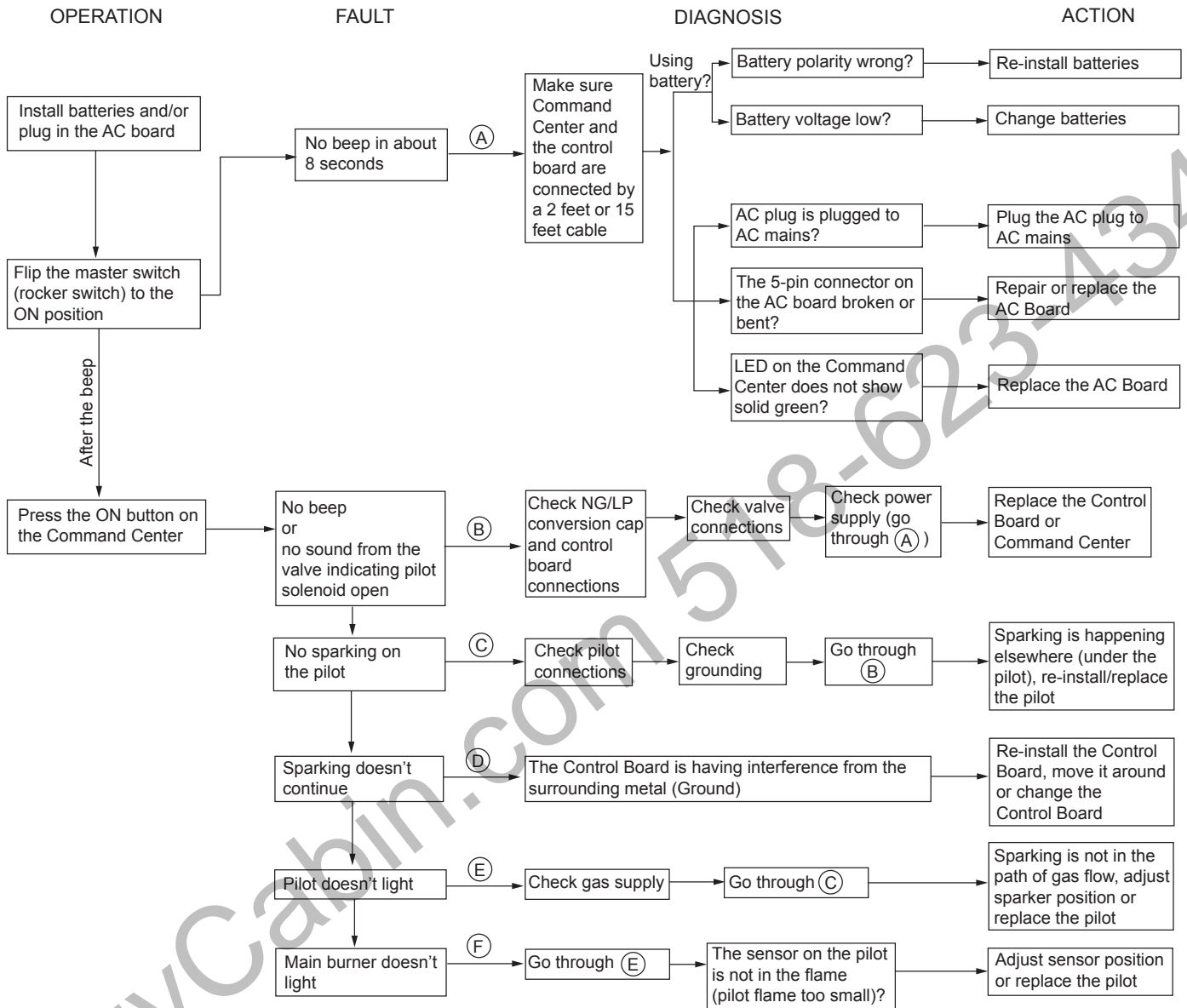

FIREBOX COMPONENTS

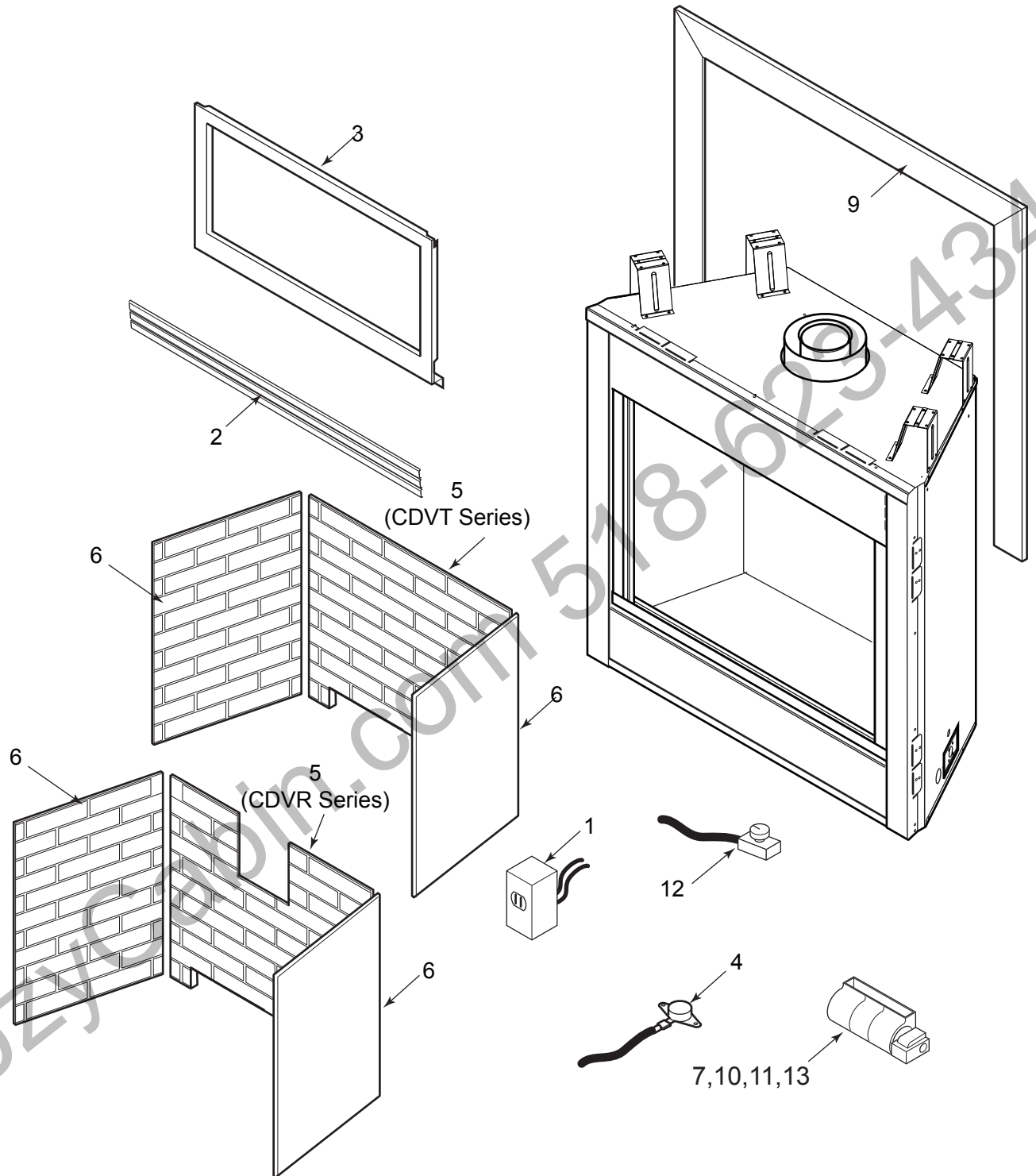

FIREBOX COMPONENTS

| Item | Description | Qty. | CDVR33 | CDVT33 | CDVR36 | CDVT36 | CDVR42 | CDVT42 | CDVR47 | CDVT47 |
|--|--|------|-----------|----------|----------|----------|----------|----------|----------|----------|
| Standard Features | | | | | | | | | | |
| 1. | Junction Box Assy | 1 | 26D2128K | 26D2128K | 26D2128K | 26D2128K | 26D2128K | 26D2128K | 26D2128K | 26D2128K |
| 2. | Black Louver | 6 | 54D0246 | 54D0246 | 26D0695 | 26D0695 | 26D0697 | 26D0697 | 26D0699 | 26D0699 |
| 3. | Glass Frame Assy | 1 | 69D0238K | 69D0238K | 69D0028K | 69D0028K | 69D1107K | 69D1107K | 69D2105K | 69D2105K |
| Factory Installed Service Parts | | | | | | | | | | |
| 2. | Brass Louver | 6 | 54D0249K | 54D0249K | 26D0701K | 26D0701K | 26D0703K | 26D0703K | 26D0705K | 26D0705K |
| 4. | Thermostat Sensor for Blower | 1 | 26D2870 | 26D2870 | 26D2870 | 26D2870 | 26D2870 | 26D2870 | 26D2870 | 26D2870 |
| 5. | Firebrick Rear - Cottage Clay | 1 | 69D0221K | 26D7069K | 69D0040K | 69D0041K | 69D1023K | 69D1022K | 69D2019K | 69D2020K |
| 5. | Firebrick Rear - Tavern Brown | 1 | 69D0222K | 54D0284K | 69D0044K | 69D0045K | 69D1025K | 69D1024K | 69D2021K | 69D2022K |
| 6a. | Firebrick Right / Left - Cottage Clay | 2 | 26D7068K | 26D7068K | 69D0042K | 69D0042K | 69D0042K | 69D0042K | 69D0042K | 69D0042K |
| 6b. | Firebrick Right / Left - Cottage Clay - CDVR33SC7(117) ONLY | 2 | 20300900K | -- | -- | -- | -- | -- | -- | -- |
| 6a. | Firebrick Right / Left - Tavern Brown | 2 | 54D0285K | 54D0285K | 69D0046K | 69D0046K | 69D0046K | 69D0046K | 69D0046K | 69D0046K |
| 6b. | Firebrick Right / Left - Tavern Brown - CDVR33SC7(117) ONLY | 2 | 20301197K | -- | -- | -- | -- | -- | -- | -- |
| 7. | Blower Motor | 1 | 93D0006K | 93D0006K | 93D0006K | 93D0006K | 93D0006K | 93D0006K | 93D0006K | 93D0006K |
| Accessories/Field Installed Options | | | | | | | | | | |
| 2. | Brass Louver | 1 | L30BR | L30BR | L32BR | L32BR | L36BR | L36BR | L42BR | L42BR |
| 2. | Pewter Louver | 1 | L30PW | L30PW | L32PW | L32PW | L36PW | L36PW | L42PW | L42PW |
| 9. | Curved Design - Brass Trim | 1 | BRTK30C | BRTC30C | BRTK32C | BRTK32C | BRTK36C | BRTK36C | BRTK42C | BRTK42C |
| 9. | Curved Design - Pewter Trim | 1 | PWTK30C | PWTK30C | PWTK32C | PWTK32C | PWTK36C | PWTK36C | PWTK36C | PWTK36C |
| 10. | T-stat Blower w/ Speed Control | 1 | BLOT | BLOT | BLOT | BLOT | BLOT | BLOT | BLOT | BLOT |
| 11. | Manual Blower | 1 | FK12 | FK12 | FK12 | FK12 | FK12 | FK12 | FK12 | FK12 |
| 12. | Speed Control | 1 | 26D0746 | 26D0746 | 26D0746 | 26D0746 | 26D0746 | 26D0746 | 26D0746 | 26D0746 |
| 13. | SCS Blower w/ Speed Control & Time Delay | 1 | BLOTSC | BLOTSC | BLOTSC | BLOTSC | BLOTSC | BLOTSC | BLOTSC | BLOTSC |
| 14. | Mesh Glass Cover (not shown) | | DVC300SD | DVC300SD | DVC400SD | DVC400SD | DVC500SD | DVC500SD | DVC600SD | DVC600SD |

STANDING PILOT — MILLIVOLT CONTROL

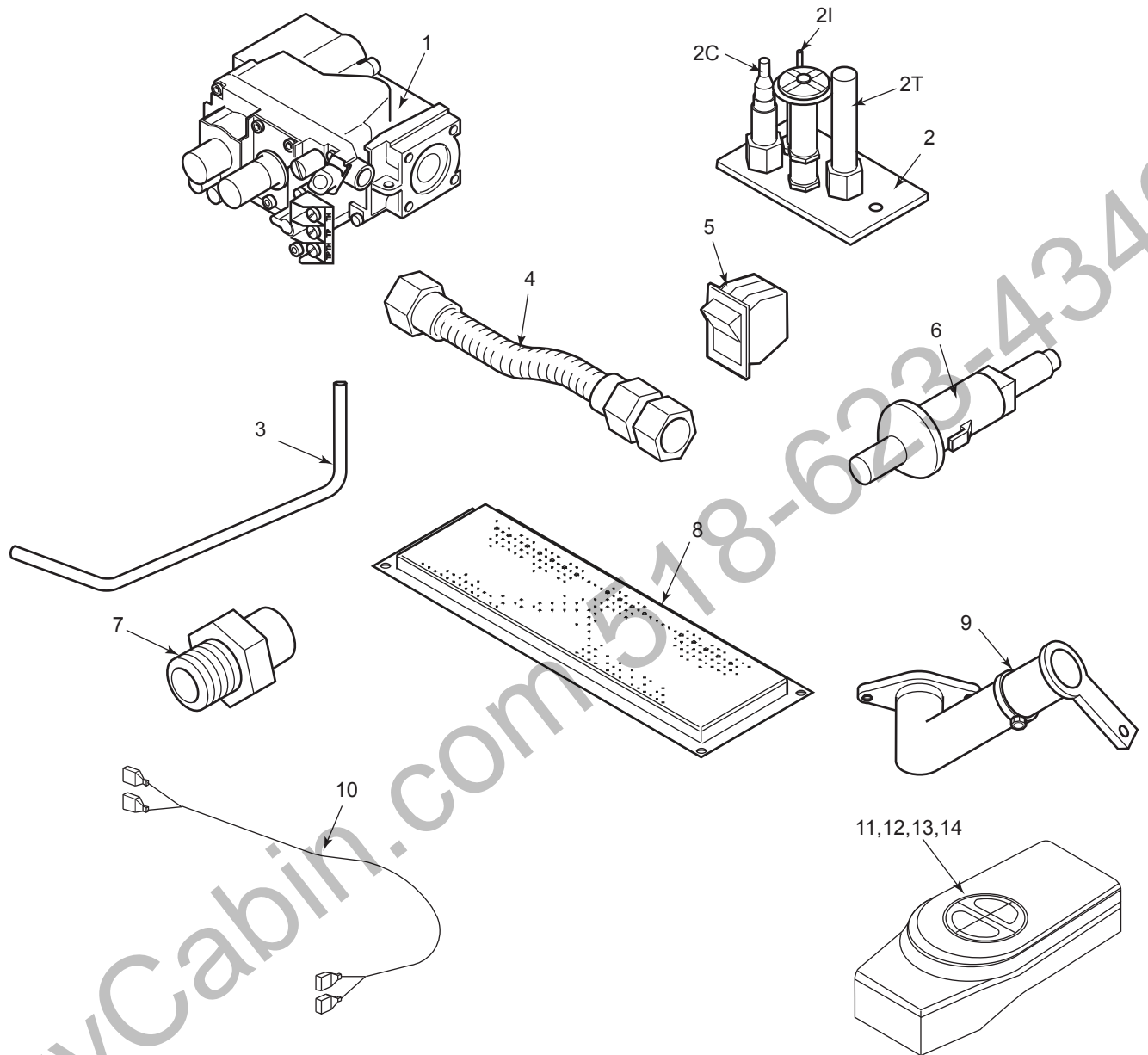

STANDING PILOT – MILLIVOLT CONTROL

| Item | Description | Qty. | CDV33NV7(117) | CDV33PV7(117) | CDV36NV7 | CDV36PV7 | CDV42NV7 | CDV42PV7 | CDV47NV7 | CDV47PV7 |
|------|------------------------------|------|---------------|---------------|----------|----------|----------|----------|----------|----------|
| 1. | Gas Valve Assy. | 1 | 37D0117 | 37D0118 | 37D0117 | 37D0118 | 37D0117 | 37D0118 | 37D0117 | 37D0118 |
| 2. | Pilot Assembly | 1 | 37D0018 | 37D0019 | 37D0018 | 37D0019 | 37D0018 | 37D0019 | 37D0018 | 37D0019 |
| 2C. | Replacement Thermocouple | 1 | 37D1067 | 37D1067 | 37D1067 | 37D1067 | 37D1067 | 37D1067 | 37D1067 | 37D1067 |
| 2I. | Replacement Igniter and Wire | 1 | 37D1069 | 37D1069 | 37D1069 | 37D1069 | 37D1069 | 37D1069 | 37D1069 | 37D1069 |
| 2T. | Replacement Thermopile | 1 | 37D1068 | 37D1068 | 37D1068 | 37D1068 | 37D1068 | 37D1068 | 37D1068 | 37D1068 |
| 3. | Burner Tube | 1 | 54D0288 | 54D0288 | 69D0034 | 69D0034 | 69D0034 | 69D0034 | 69D0034 | 69D0034 |
| | CDVR33117 ONLY | | 20303660 | 20303660 | -- | -- | -- | -- | -- | -- |
| 4. | Flexhose with Shut-off Valve | 1 | 69D0030 | 69D0030 | 69D0030 | 69D0030 | 69D0030 | 69D0030 | 69D0030 | 69D0030 |
| 5. | Rocker Switch | 1 | 41D0048 | 41D0048 | 41D0048 | 41D0048 | 41D0048 | 41D0048 | 41D0048 | 41D0048 |
| 6. | Piezo Igniter | 1 | 14D0503 | 14D0503 | 14D0503 | 14D0503 | 14D0503 | 14D0503 | 14D0503 | 14D0503 |
| 7. | Injector | 1 | 58D0371 | 69D0226 | 59D0062 | 69D0079 | 20H3155 | 33D4046 | 20H3155 | 33D4046 |
| 8. | Burner Assembly | 1 | 54D0200 | 54D0200 | 54D0001 | 54D0001 | 54D0329 | 54D0329 | 54D0329 | 54D0329 |
| 9. | Venturi | 1 | 69D1119 | 69D1026 | 69D1119 | 69D1026 | 69D1119 | 69D1026 | 69D1119 | 69D1026 |
| 10. | Wire Assembly | 1 | 44D0500 | 44D0500 | 44D0500 | 44D0500 | 44D0500 | 44D0500 | 44D0500 | 44D0500 |
| 10. | Wire Assembly | 1 | 44D0501 | 44D0501 | 44D0501 | 44D0501 | 44D0501 | 44D0501 | 44D0501 | 44D0501 |

Accessories

| Item | Description | Qty. | Part Number |
|------|-----------------------------|------|--|
| 11. | Thermostatic Remote Control | 1 | RCST, RCT, RCSTE, RCSTEB, RCSITE, WWTD |
| 12. | Remote Control ON/OFF | 1 | RCB, RCMT, RCBE, WMTD |
| 13. | Wall Switch Kit | 1 | MVWS |
| 14. | Wall Thermostat Kit | 1 | WT |

Fuel Conversion Kits - Millivolt**Natural Gas to LP**

| | |
|-----------------|------------------|
| CDV(R,T)33(V,E) | Kit #CDV33CKP |
| CDVR33PV117 | Kit #CDVR3311CKP |
| CDV(R,T)36(V,E) | Kit #CDV36CKP |
| CDV(R,T)42(V,E) | Kit #CDV42CKP |
| CDV(R,T)47(V,E) | Kit #CDV47CKP |

LP to Natural Gas

| | |
|-----------------|------------------|
| CDV(R,T)33(V,E) | Kit #CDV33CKN |
| CDVR33NV117 | Kit #CDVR3311CKN |
| CDV(R,T)36(V,E) | Kit #CDV36CKN |
| CDV(R,T)42(V,E) | Kit #CDV42CKN |
| CDV(R,T)47(V,E) | Kit #CDV47CKN |

ELECTRONIC IGNITION

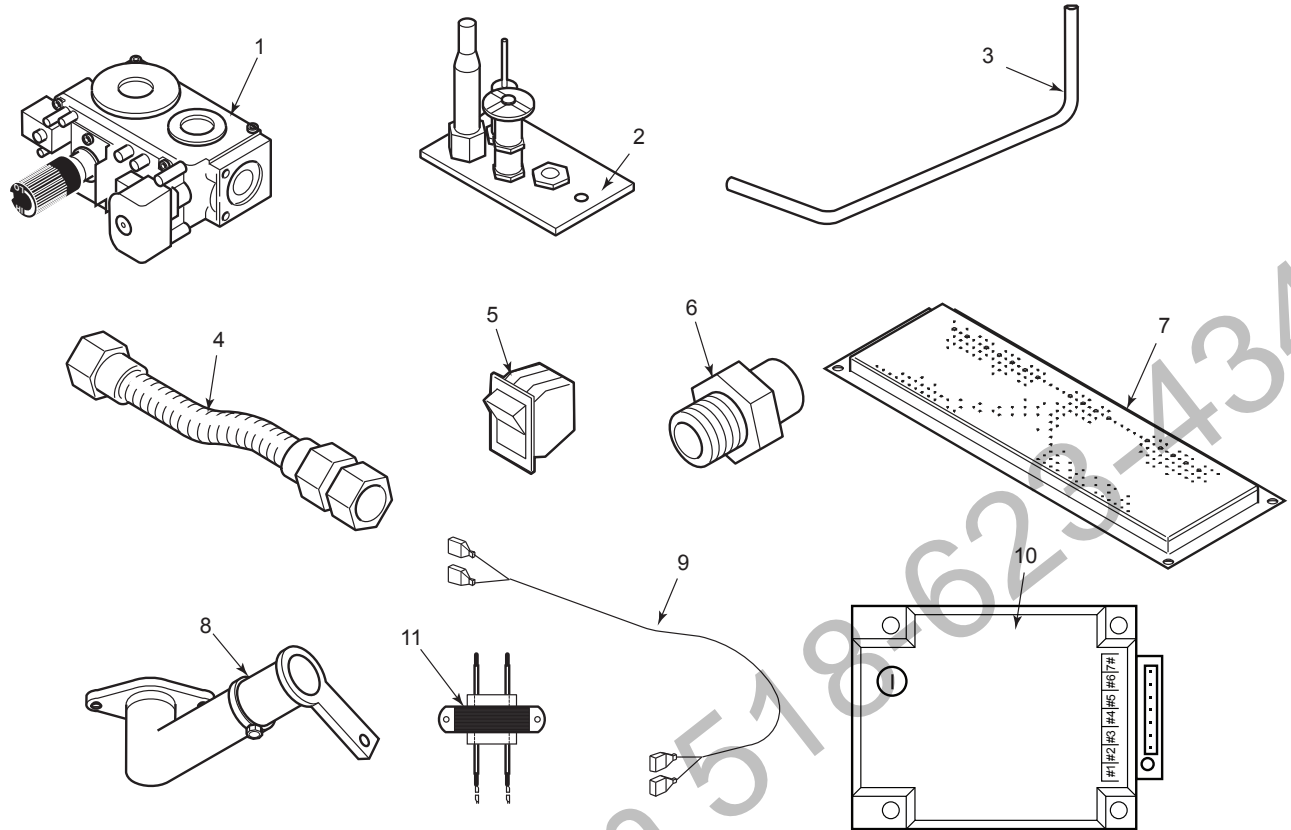

| Item | Description | Qty. | CDV33NE7 | CDV33PE7 | CDV36NE7 | CDV36PE7 | CDV42NE7 | CDV42PE7 | CDV47NE1 | CDV47PE7 |
|------|------------------------------|------|----------|----------|----------|----------|----------|----------|----------|----------|
| 1. | Gas Valve Assy. | 1 | 37D0016 | 37D0017 | 37D0016 | 37D0017 | 37D0016 | 37D0017 | 37D0016 | 37D0017 |
| 2. | Pilot Assembly | 1 | 37D0020 | 37D0021 | 37D0020 | 37D0021 | 37D0020 | 37D0021 | 37D0020 | 37D0021 |
| 3. | Burner Tube | 1 | 54D0288 | 54D0288 | 69D0034 | 69D0034 | 69D0034 | 69D0034 | 69D0034 | 69D0034 |
| 4. | Flexhose with Shut-off Valve | 1 | 69D0030 | 69D0030 | 69D0030 | 69D0030 | 69D0030 | 69D0030 | 69D0030 | 69D0030 |
| 5. | Rocker Switch | 1 | 41D0048 | 41D0048 | 41D0048 | 41D0048 | 41D0048 | 41D0048 | 41D0048 | 41D0048 |
| 6. | Injector | 1 | 58D0371 | 69D0226 | 59D0062 | 69D0079 | 20H3155 | 33D4046 | 20H3155 | 33D4046 |
| 7. | Burner Assembly | 1 | 54D0200 | 54D0200 | 54D0001 | 54D0001 | 54D0329 | 54D0329 | 54D0329 | 54D0329 |
| 8. | Venturi | 1 | 69D1119 | 69D1026 | 69D1119 | 69D1026 | 69D1119 | 69D1026 | 69D1119 | 69D1026 |
| 9. | Wire Assembly | 1 | 54D0207 | 54D0207 | 54D2007 | 54D2007 | 54D0207 | 54D0207 | 54D0207 | 54D0207 |
| 10. | Ignition Module | 1 | 37D0325 | 37D0325 | 37D0325 | 37D0325 | 37D0325 | 37D0325 | 37D0325 | 37D0325 |
| 11. | Transformer | 1 | 37D0027 | 37D0027 | 37D0027 | 37D0027 | 37D0027 | 37D0027 | 37D0027 | 37D0027 |

Fuel Conversion Kits - Electronic

Natural Gas to LP

- CDV33 Kit #CDV33CKEP
- CDV36 Kit #CDV36CKEP
- CDV42 Kit #CDV42CKEP
- CDV47 Kit #CDV47CKEP

LP to Natural Gas

- CDV33 Kit #CDV33CKEN
- CDV36 Kit #CDV36CKEN
- CDV42 Kit #CDV42CKEN
- CDV47 Kit #CDV47CKEN

SIGNATURE COMMAND SYSTEM

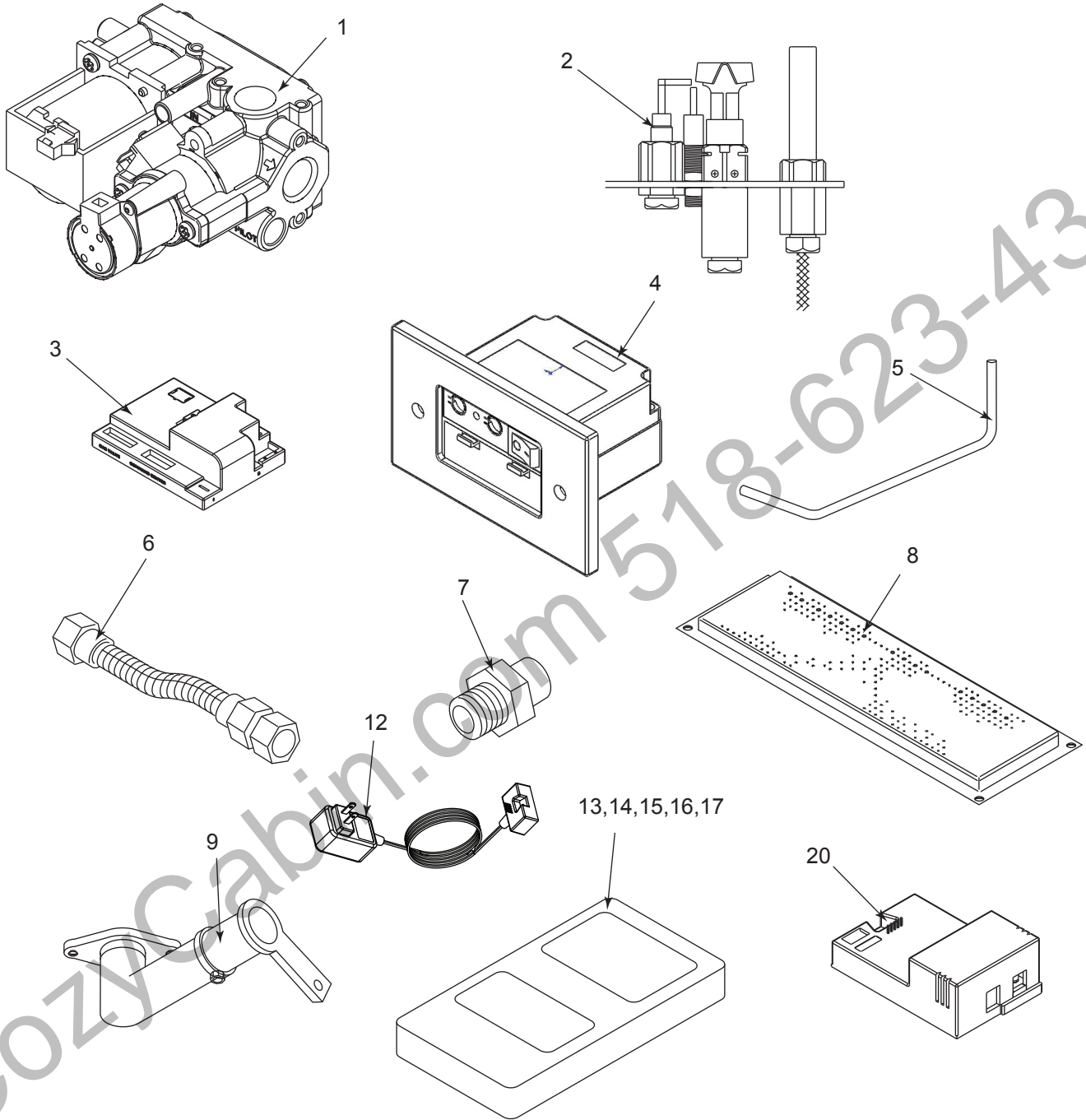

SIGNATURE COMMAND SYSTEM

| Item | Description | Qty. | CDVR33 NSC117 | CDVR33 PSC117 | CDVT33 NSC7 | CDVT33 PSC7 | CDV(R,T)36 NSC7 | CDV(R,T)36 PSC7 | CDV(R,T)42/47 NSC7 | CDV(R,T)42/47 PSC7 |
|--------------------|---|------|------------------|------------------|----------------|----------------|--------------------|--------------------|-----------------------|-----------------------|
| 1. | Gas Valve Assy. | 1 | 80D0001 | 80D0002 | 80D0001 | 80D0002 | 80D0001 | 80D0002 | 80D0001 | 80D0002 |
| 2. | Pilot Assembly | 1 | 80D0006 | 80D0007 | 80D0006 | 80D0007 | 80D0006 | 80D0007 | 80D0006 | 80D0007 |
| 3. | Control Box | 1 | 80D0018 | 80D0019 | 80D0018 | 80D0019 | 80D0018 | 80D0019 | 80D0018 | 80D0019 |
| 4. | Command Center | 1 | 80D0005 | 80D0005 | 80D0005 | 80D0005 | 80D0005 | 80D0005 | 80D0005 | 80D0005 |
| 5. | Burner Tube | 1 | 20301096 | 20301096 | 54D6029 | 54D6029 | 54D6004 | 54D6004 | 54D6004 | 54D6004 |
| 6. | Flexhose with Shutoff Valve | 1 | 69D0030 | 69D0030 | 69D0030 | 69D0030 | 69D0030 | 69D0030 | 69D0030 | 69D0030 |
| 7. | Injector | 1 | 58D0371 | 20301196 | 58D0371 | 69D0226 | 54D0062 | 69D0079 | 20H3155 | 20H3156 |
| 8. | Burner Assembly | 1 | 20300786 | 20300786 | 54D0200 | 54D0200 | 54D0001 | 54D0001 | 54D0329 | 54D0329 |
| 9. | Venturi | 1 | 69D1119 | 69D1026 | 69D1119 | 69D1026 | 69D1119 | 69D1026 | 69D1119 | 69D1026 |
| 10. | Wire Valve Control (not shown) | 1 | 80D0010 | 80D0010 | 80D0010 | 80D0010 | 80D0010 | 80D0010 | 80D0010 | 80D0010 |
| 11. | Wire Command Ctr Control Box 2' (not shown) | 1 | 80D0008 | 80D0008 | 80D0008 | 80D0008 | 80D0008 | 80D0008 | 80D0008 | 80D0008 |
| 12. | A/C Adapter (6 Volt) | 1 | 80D0041 | 80D0041 | 80D0041 | 80D0041 | 80D0041 | 80D0041 | 80D0041 | 80D0041 |
| Accessories | | | | | | | | | | |
| 13. | Hand Held Remote Control w/ HI/LO & Timer | | | | | | | | RMSC | |
| 14. | Hand Held Remote Control w/HI/LO & Tstat | | | | | | | | RTSC | |
| 15. | Touch Screen Remote w/Optional Light, Blower and Auxiliary Control | | | | | | | | TSFSC | |
| 16. | Touch Screen Remote Hi/Lo and Timer | | | | | | | | TSMSC | |
| 17. | Touch Screen Remote Hi/Lo and TStat | | | | | | | | TSTSC | |
| 18. | Wall Thermostat ON/OFF (not shown) | | | | | | | | WT | |
| 19. | SCS Wall Mount Extension Kit (15' wire, rough-in box, wall cover) (not shown) | | | | | | | | SCSWEK | |
| 20. | SCS AC Module (*Optional Blower, Light & Aux. Control) | | | | | | | | SCSACM | |

*NOTE: TSFSC must be used with SCS A/C Module to control blower, lights and aux.

Fuel Conversion Kits - Signature Command System

Natural Gas to LP

| | |
|----------------|-------------------|
| CDVR33NSC7 | Kit #CDVR3311CKPS |
| CDVT33NSC7 | Kit #CDVT33CKPS |
| CDV(R,T)36NSC7 | Kit #CDV36CKPS |
| CDV(R,T)42NSC7 | Kit #CDV42CKPS |
| CDV(R,T)47NSC7 | Kit #CDV42CKPS |

LP to Natural Gas

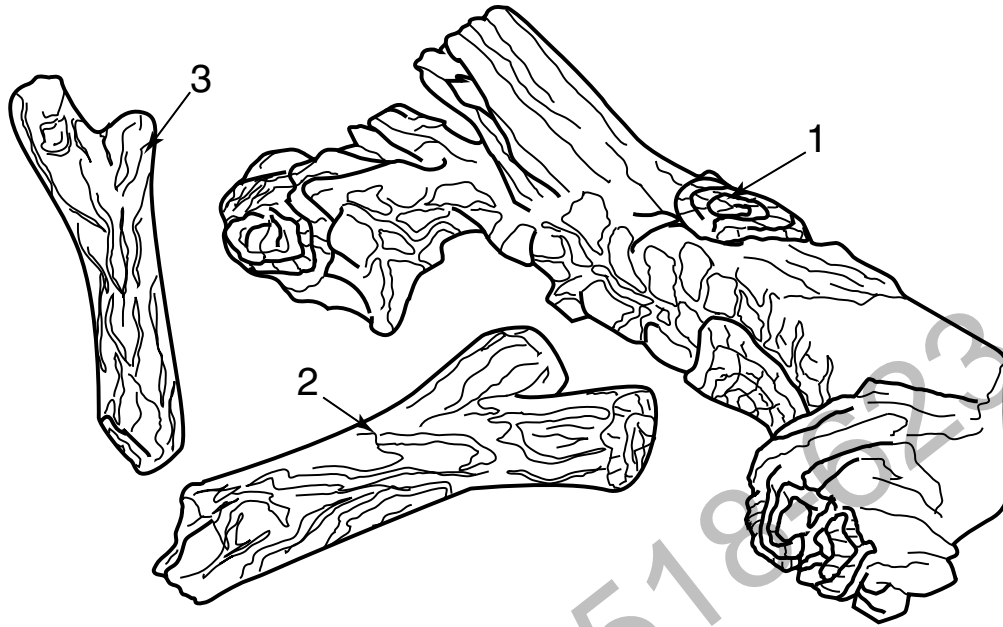

| | |
|----------------|-------------------|
| CDVR33PSC7 | Kit #CDVR3311CKNS |
| CDVT33PSC7 | Kit #CDVT33CKNS |
| CDV(R,T)36PSC7 | Kit #CDV36CKNS |
| CDV(R,T)42PSC7 | Kit #CDV42CKNS |
| CDV(R,T)47PSC7 | Kit #CDV47CKNS |

LOGS



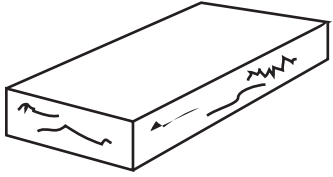
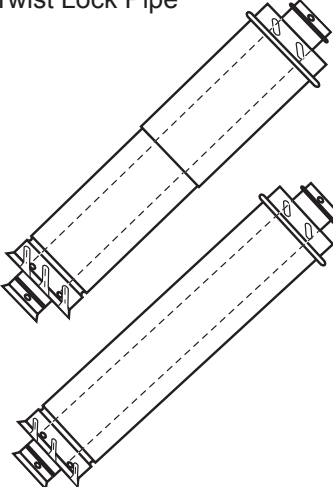

| Item | Description | CDVR33SC117 | CDVR33(V,E)7 | CDV(R,T)36(V,E,SC)7 | CDV(R,T)42(V,E,SC)7 | CDV(R,T)47(V,E,SC)7 |
|------|-------------|-------------|--------------|---------------------|---------------------|---------------------|
| 1. | Rear Log | 20301202 | 54D0121 | 54D0181 | 54D0339 | 54D0339 |
| 2. | Right Log | 54D0147 | 54D0147 | 54D0116 | 54D0361 | 54D0361 |
| 3. | Left Log | 54D0146 | 54D0146 | 54D0115 | 54D0360 | 54D0360 |

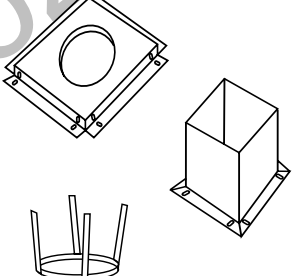
VERTICAL VENTING

| | Description | Model Number |
|---|--|--------------|
|  | Vertical Vent Termination w/ Storm Collar (flashing NOT included) | 7TDVSKV |
| | Vertical Vent Termination w/ Storm Collar - 8 pack (flashing NOT included) | 7TDVSKV/8 |
| | Vertical Vent Termination w/ 1/12 - 6/12 Flashing, Storm Collar and Ceiling Support Kit | 7TDVSKVA* |
| | Vertical Vent Termination w/ 6/12 - 12/12 Flashing, Storm Collar and Ceiling Support Kit | 7TDVSKVB* |
| | Vertical Vent Termination w/ Flat Flashing, Storm Collar and Ceiling Support Kit | 7TDVSKVF* |
|  | 20" Rigid Pipe - single pack | 7TDVP20 |
| | 30" Flex Pipe - single pack | 7FDVP30 |
| | 12" - 18" Adjustable Vent Length | 7TDVP1218 |
| | 35" - 64" Adjustable Vent Length | 7TDVP3564 |
| | 8" Vent Pipe - 4 pack | 7TDVP8/4 |
| | 12" Vent Pipe - 4 pack | 7TDVP12/4 |
| | 24" Vent Pipe - 4 pack | 7TDVP24/4 |
| | 36" Vent Pipe | 7TDVP36 |
| | 36" Vent Pipe - 30 pack | 7TDVP36/30 |
| | 48" Vent Pipe | 7TDVP48 |
| | 48" Vent Pipe - 30 pack | 7TDVP48/30 |
|  | 45° Elbow for Vertical/Horizontal Offset | 7TDV45 |
| | 45° Elbow for Vertical Offsets - 8 pack | 7TDV45/8 |
| | 90° Elbow for Vertical/Horizontal Offset | 7TDV90 |
| | 90° Elbow for Vertical/Horizontal Offset - 8 pack | 7TDV90/8 |
|  | 1" Firestop | 7DV1FS |
| | 1" Attic Insulation Shield | 7DV1AIS |
| | Combination Horizontal Offset/Roof Support | 7DVCS |

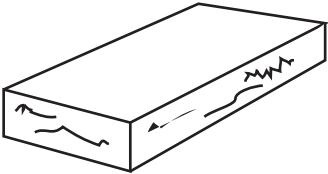
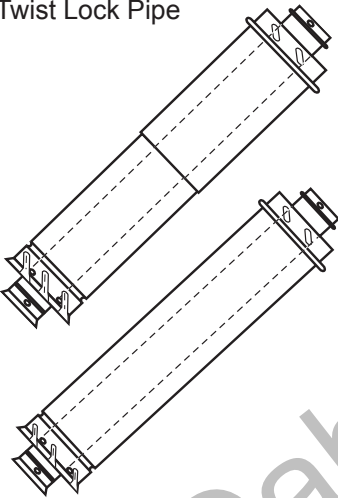
HORIZONTAL VENTING

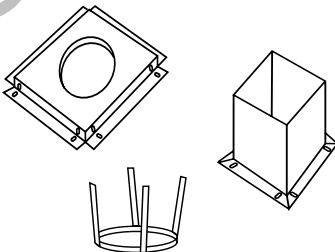
| | Description | Model Number |
|---|--|---------------------|
| Horizontal Vent Termination Kits  | Rear Vent Hot Touch Termination Kit w/ 10" to 16" Adjustable Termination Pipe, Firestop, and Hot Touch Termination w/ Siding Shield | 7TBRHTK |
| | Up and Out Side Wall Termination Kit w/ 10" to 16" Adjustable Termination Pipe, 90° Elbow, Firestop, and Cool Touch Termination w/ Siding Shield | 7TDVSCTK |
| | Rear Vent Cool Touch Termination w/ Siding Shield for Straight-out Applications and Firestop - 8 pack | 7TRVCT/8 |
| | Rear Vent Hot Touch Termination w/ Siding Shield for Straight-out Applications and Firestop - 8 pack | 7TRVHT/8 |
| | Termination Guard for 7" T.L. Rear Vent Hot Touch Terminations (97TRVT/7TSVKT) | 7TRVTG |
| | Snorkel Termination | 7TDVSNORK |
| | 7" T.L. DVRTSB Termination Screen Guard | 7TBSG |
| | Up and Out Starter Kit w/ 40" Flex Pipe, Firestop, Cool Touch Termination w/ Siding Shield, and 2 ea. Clamp Bands | 7FDVSCTK |
| Twist Lock Pipe  | 20" Termination Pipe - 8 pack | 7TDVP20/8 |
| | 10" - 16" Adjustable Termination Pipe - 4 pack | 7TDVPA/4 |
| | 12" - 18" Adjustable Vent Length | 7TDVP1218 |
| | 35" - 64" Adjustable Vent Length | 7TDVP3564 |
| | 8" Vent Pipe - 4 pack | 7TDVP8/4 |
| | 12" Vent Pipe - 4 pack | 7TDVP12/4 |
| | 24" Vent Pipe - 4 pack | 7TDVP24/4 |
| | 36" Vent Pipe | 7TDVP36 |
| | 36" Vent Pipe - 30 pack | 7TDVP36/30 |
| | 48" Vent Pipe | 7TDVP48 |
| 48" Vent Pipe - 30 pack | 7TDVP48/30 | |
| Twist Lock Elbows  | 45° Elbow for Vertical/Horizontal Offset | 7TDV45 |
| | 45° Elbow for Vertical Offsets - 8 pack | 7TDV45/8 |
| | 90° Elbow for Vertical/Horizontal Offset | 7TDV90 |
| | 90° Elbow for Vertical/Horizontal Offset - 8 pack | 7TDV90/8 |
| Shields and Supports  | 1" Firestop | 7DV1FS |
| | 3" Firestop | 7DV3FS |
| | 1" Attic Insulation Shield | 7DV1AIS |
| | Combination Horizontal Offset/Roof Support | 7DVCS |

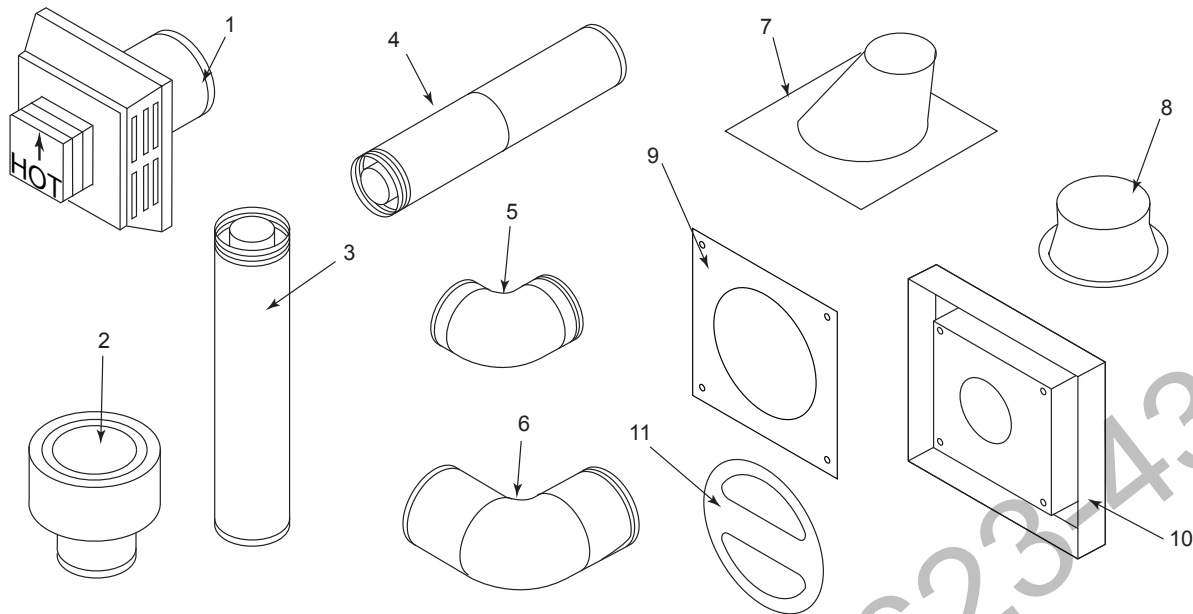

**VENT COMPONENTS FOR 4" X 6⁵/₈" (Duravent, Selkirk)
4" x 6¹/₂" (Metal-Fab)**

| Item | Qty./Box | Description | Current Duravent or Vermont Castings Group Part no. | Old Duravent or Vermont Castings Group Part no. | Selkirk Part no. | Metal-Fab Part no. |
|------|----------|---|---|---|------------------|--------------------|
| 1 | 1 | Thru-roof Flexible Pipe Termination Kit with flex adapter 24" rigid pipe, roof support 4" x 6 ⁵ / ₈ " and termination cap | TRFK | -- | -- | -- |
| 1 | 1 | Horizontal Square Termination Cap with built-in vinyl siding standoff, heat deflector and firestop | BHRTK | BHRTK | -- | -- |
| 1 | 1 | Square Horizontal Termination Cap | 46DVA-HC | 985 | 4DT-HC | 4DHT |
| 1 | 1 | Round Horizontal Termination Cap | 46DVS-HRCS | -- | -- | -- |
| 1 | 1 | Sconce Termination Cap (aluminum) | 46DVA-HSC | -- | -- | -- |
| 2 | 1 | Low-Profile Vertical Termination Cap | 46DVA-VC | 980 | 4DT-VC | 4DVT |
| 3 | 6 | 6" Pipe Length (galvanized) | 46DVA-06 | 908 | 4DT-06 | 4DV6 |
| 3 | 6 | 9" Pipe Length (galvanized) | 46DVA-09 | 907 | 4DT-09 | -- |
| 3 | 6 | 12" Pipe Length (galvanized) | 46DVA-12 | 906 | 4DT-1 | 4D12 |
| 3 | 6 | 24" Pipe Length (galvanized) | 46DVA-24 | 904 | 4DT-4 | 4D24 |
| 3 | 6 | 36" Pipe Length (galvanized) | 46DVA-36 | 903 | 4DT-36 | 4D36 |
| 3 | 6 | 48" Pipe Length (galvanized) | 46DVA-48 | 902 | 4DT-48 | 4D48 |
| 4 | 6 | 8 ¹ / ₂ " Pipe Extension (galvanized) | 46DVA-08A | -- | 4DT-AJ | -- |
| 4 | 6 | 16" Pipe Extension (galvanized) | 46DVA-16A | -- | 4DT-AJ14 | -- |
| 5 | 6 | 45° Elbow (galvanized) | 46DVA-E45 | 945 | 4DT-EL45 | 4D45L |
| 6 | 6 | 90° Elbow (galvanized) | 46DVA-E90 | 990 | 4DT-EL90 | 4D90L |
| 7 | 6 | Adjustable Roof Flashing 0/12 - 6/12 | 46DVA-F6 | 943 | 4DT-AF6 | 4DF |
| 8 | 6 | Storm Collar | 46DVA-SC | 953 | 4DT-SC | 4F5C |
| 9 | 6 | 1" Firestop | 46DVA-FS | 963 | 4DT-FS | 4DF5 |
| 9 | 6 | 3" Firestop | FS3 | -- | -- | -- |
| 10 | 1 | Vinyl Siding Standoff | 46DVA-VSS | 950 | 4DT-VS | 4DVS |
| 11 | 1 | Restrictor Disk | 45D0551 | 45D0551 | -- | -- |
| | 1 | Attic Insulation Shield | 46DVA-IS | -- | -- | -- |
| | 6 | Steep Roof Flashing 7/12 - 12/12 | 46DVA-F12 | 943S | -- | -- |
| | 8 | Horizontal Termination with 1" firestop | BHRT/8 | -- | -- | -- |
| | 8 | Flex Adapter Starter | DVFFA/8 | -- | -- | -- |
| | | Reducer Adapter (from 4" x 7") | MBSPA | -- | -- | 4DMA |

For more information about, or instructions for, the venting components referenced, please contact the component manufacturer:
 Selkirk Corporation: www.selkirkcorp.com or 800-992-8368; Duravent: www.duravent.com or 800-835-4429;
 Metal-Fab, Inc.: www.metal-fabinc.com or 316-943-2351

CozyCabin.com 518-623-4349

CozyCabin.com 518-623-4349

Massachusetts Residents Only — Please read and follow these special requirements

NOTE REGARDING VENTED PRODUCTS

This product must be installed by a licensed plumber or gas fitter when installed within the Commonwealth of Massachusetts.

Any residence with a direct vent product must have a CO detector installed in the residence.

Installation of the fireplace or vented gas log in the State of Massachusetts requires the damper to be permanently removed or welded in the fully open position.

In addition, a naturally vented gas log may not be installed in a bedroom or bathroom in the State of Massachusetts.

Flex line installation must not exceed 36 inches and must have a T shutoff valve.

NOTE REGARDING VENT FREE PRODUCTS

This product must be installed by a licensed plumber or gas fitter when installed within the Commonwealth of Massachusetts.

In addition, vent free products may not be installed in a bedroom or bathroom regardless of size or type in the State of Massachusetts.

Flex line installation must not exceed 36 inches and must have a T shutoff valve.

CARBON MONOXIDE DETECTOR REQUIREMENTS

(2) Revise 10.8.3 by adding the following additional requirements:

(a) For all side wall horizontally vented gas fueled equipment installed in every dwelling, building or structure used in whole or in part for residential purposes, including those owned or operated by the Commonwealth and where the side wall exhaust vent termination is less than seven (7) feet above finished grade in the area of the venting, including but not limited to decks and porches, the following requirements shall be satisfied:

1. **Installation of carbon monoxide detectors.** At the time of installation of the side wall horizontal vented gas fueled equipment, the installing plumber or gas fitter shall observe that a hard wired carbon monoxide detector with an alarm and battery back-up is installed on the floor level where the gas equipment is to be installed. In addition, the installing plumber or gas fitter shall observe that a battery operated or hard wired carbon monoxide detector with an alarm is installed on each additional level of the dwelling, building or structure served by the side wall horizontal vented gas fueled equipment. It shall be the responsibility of the property owner to secure the services of qualified licensed professionals for the installation of hard wired carbon monoxide detectors

a. In the event that the side wall horizontally vented gas fueled equipment is installed in a crawl space or an attic, the hard wired carbon monoxide detector with alarm and battery back-up may be installed on the next adjacent floor level.

b. In the event that the requirements of this subdivision can not be met at the time of completion of installation, the owner shall have a period of thirty (30) days to comply with the above requirements; provided, however, that during said thirty (30) day period, a battery operated carbon monoxide detector with an alarm shall be installed.

2. **Approved Carbon Monoxide Detectors.** Each carbon monoxide detector as required in accordance with the above provisions shall comply with NFPA 720 and be ANSI/UL 2034 listed and IAS certified.

3. **Signage.** A metal or plastic identification plate shall be permanently mounted to the exterior of the building at a minimum height of eight (8) feet above grade directly in line with the exhaust vent terminal for the horizontally vented gas fueled heating appliance or equipment. The sign shall read, in print size no less than one-half (1/2) inch in size, "GAS VENT DIRECTLY BELOW. KEEP CLEAR OF ALL OBSTRUCTIONS."

4. **Inspection.** The state or local gas inspector of the side wall horizontally vented gas fueled equipment shall not approve the installation unless, upon inspection, the inspector observes carbon monoxide detectors and signage installed in accordance with the provisions of 248 CMR 5.08(2)(a)1 through 4.

(b) **Exemptions:** The following equipment is exempt from 248 CMR 5.08(2)(a)1 through 4:

1. The equipment listed in Chapter 10 entitled "Equipment Not Required To Be Vented" in the most current edition of NFPA 54 as adopted by the Board; and

2. Product Approved side wall horizontally vented gas fueled equipment installed in a room or structure separate from the dwelling, building or structure used in whole or in part for residential purposes.

(c) **Manufacturer requirements — Gas Equipment Venting System Provided.** When the manufacturer of Product Approved side wall horizontally vented gas equipment provides a venting system design or venting system components with the equipment, the instructions provided by the manufacturer for installation of the equipment and the venting system shall include:

1. Detailed instructions for the installation of the venting system design or the venting system components; and

2. A complete parts list for the venting system design or venting system.

(d) **Manufacturer requirements — Gas Equipment Venting System Not Provided.** When the manufacturer of a Product Approved side wall horizontally vented gas fueled equipment does not provide the parts for venting the flue gases, but identifies "special venting systems," the following requirements shall be satisfied by the manufacturer:

1. The referenced "special venting system" instructions shall be included with the appliance or equipment installation instructions; and

2. The "special venting systems" shall be Product Approved by the Board, and the instructions for that system shall include a parts list and detailed installation instructions.

(e) A copy of all installation instructions for all Product Approved side wall horizontally vented gas fueled equipment, all venting instructions, all parts lists for venting instructions, and/or all venting design

LIMITED LIFETIME WARRANTY POLICY

LIFETIME WARRANTY

The following components are warranted for life to the original owner, subject to proof of purchase: Firebox, Combustion Chamber, Heat Exchanger, Grate and Stainless Steel Burners.

FIVE YEAR WARRANTY

The following components are warranted five (5) years to the original owner, subject of proof of purchase: Ceramic Fiber Logs.

BASIC WARRANTY

Vermont Castings Group warrants the components and materials in your gas appliance to be free from manufacturing and material defects for a period of two years from date of installation. After installation, if any of the components manufactured by Vermont Castings Group in the appliance are found to be defective in materials or workmanship, Vermont Castings Group will, at its option, replace or repair the defective components at no charge to the original owner. Vermont Castings Group will also pay for reasonable labor costs incurred in replacing or repairing such components for a period of two years from date of installation. Any products presented for warranty repair must be accompanied by a dated proof of purchase.

This Limited Lifetime Warranty will be void if the appliance is not installed by a qualified installer in accordance with the installation instructions. The Limited Lifetime Warranty will also be void if the appliance is not operated and maintained according to the operating instructions supplied with the appliance, and does not extend to (1) firebox/burner assembly damage by accident, neglect, misuse, abuse, alterations, negligence of others, including the installation thereof by unqualified installers, (2) the costs of removal, reinstallation or transportation of defective parts on the appliance, or (3) incidental or consequential damage. All service work must be performed by an authorized service representative.

This warranty is expressly in lieu of other warranties, express or implied, including the warranty of merchantability of fitness for purpose and of all other obligations or liabilities. Vermont Castings Group does not assume for it any other obligations or liabilities in connection with sale or use of the appliance. It states that do not allow limitations on how long an implied warranty lasts, or do not allow exclusion of indirect damage, those limitations of exclusions may not apply to you. You may also have additional rights not covered in the Limited Lifetime Warranty.

Vermont Castings Group reserves the right to investigate any and all the claims against the Limited Lifetime Warranty and decide upon method of settlement.

IF WARRANTY SERVICE IS NEEDED...

1. Contact your supplier. Make sure you have your warranty, your sales receipt and the model/serial number of your Vermont Castings Group product.
2. DO NOT ATTEMPT TO DO ANY SERVICE WORK YOURSELF.

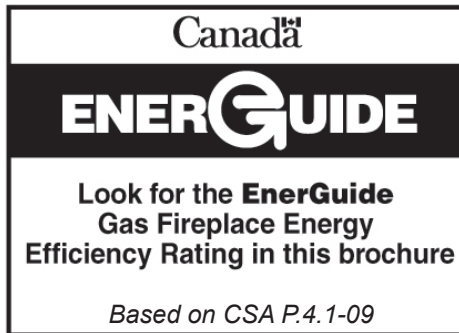

| Efficiency Ratings | |
|--------------------|---|
| Model | EnerGuide Ratings Fireplace Efficiency (%) |
| CDVR33NV7 | 62.6 |
| CDVR33NV117 | 57.6 |
| CDVR33NE7 | 66.8 |
| CDVR33NSC117 | 57.6 |
| CDVR36NV7 | 47.7 |
| CDVR36NE7 | 49.7 |
| CDVR36NSC7 | 49.7 |
| CDVR42NV7 | 66.8 |
| CDVR42NE7 | 71.0 |
| CDVR42NSC7 | 71.0 |
| CDVR47NV7 | 65.6 |
| CDVR47NE7 | 69.6 |
| CDVR47NSC7 | 69.6 |
| CDVR33PV7 | 64.3 |
| CDVR33PV117 | 64.3 |
| CDVR33PE7 | 68.1 |
| CDVR33PSC117 | 64.3 |
| CDVR36PV7 | 53.6 |
| CDVR36PE7 | 56.1 |
| CDVR36PSC7 | 56.1 |
| CDVR42PV7 | 68.7 |
| CDVR42PE7 | 72.3 |
| CDVR42PSC7 | 72.3 |
| CDVR47PV7 | 67.1 |
| CDVR47PE7 | 70.6 |
| CDVR47PSC7 | 70.6 |

| Efficiency Ratings | |
|--------------------|---|
| Model | EnerGuide Ratings Fireplace Efficiency (%) |
| CDVT33NV7 | 45.9 |
| CDVT33NE7 | 47.6 |
| CDVT33NSC7 | 47.6 |
| CDVT36NV7 | 47.7 |
| CDVT36NE7 | 49.7 |
| CDVT36NSC7 | 47.6 |
| CDVT42NV7 | 56.3 |
| CDVT42NE7 | 59.1 |
| CDVT42NSC7 | 59.1 |
| CDVT47NV7 | 54.2 |
| CDVT47NE7 | 56.6 |
| CDVT47NSC7 | 56.6 |
| CDVT33PV7 | 53.0 |
| CDVT33PE7 | 55.4 |
| CDVT33PSC7 | 55.4 |
| CDVT36PV7 | 53.6 |
| CDVT36PE7 | 56.1 |
| CDVT36PSC7 | 55.4 |
| CDVT42PV7 | 64.3 |
| CDVT42PE7 | 67.6 |
| CDVT42PSC7 | 67.6 |
| CDVT47PV7 | 62.4 |
| CDVT47PE7 | 65.7 |
| CDVT47PSC7 | 65.7 |

Vermont Castings Group

149 Cleveland Drive • Paris, Kentucky 40361
www.vermontcastingsgroup.com