



WARRANTY REGISTRATION  
enviro.com/warranty

## Boston 1200 FPI & Boston 1700 FPI

WOOD STOVE INSERT

# OWNER'S MANUAL



PLEASE READ THIS ENTIRE MANUAL BEFORE INSTALLATION AND USE OF THIS WOOD BURNING ROOM HEATER. FAILURE TO FOLLOW THESE INSTRUCTIONS COULD RESULT IN PROPERTY DAMAGE, BODILY HARM, OR EVEN DEATH.

CONTACT YOUR BUILDING OR FIRE OFFICIALS ABOUT RESTRICTIONS AND INSTALLATION INSPECTION REQUIREMENTS IN YOU AREA.

THIS HEATER MEETS THE 2015 U. S. ENVIRONMENTAL PROTECTION AGENCY'S CRIB-WOOD EMISSION LIMITS FOR WOOD HEATERS SOLD AFTER MAY 15, 2015. UNDER SPECIFIC CONDITIONS THIS HEATER HAS BEEN SHOWN TO DELIVER HEAT AT RATES RANGING FROM 11,479 TO 34,196 BTU PER HOUR FOR THE 1200 AND FROM 9,425 TO 31,780 BTU PER HOUR FOR THE 1700. THESE STOVES HAVE BEEN CERTIFICATION TESTED TO STANDARDS UL-1482-11 AND ULC-S627-00. CERTIFICATION TESTING COMPLETED BY OMNI-TEST LABORATORIES.

Tested &  
Listed By



Portland  
Oregon USA

OMNI-Test Laboratories, Inc.  
Report # 268-S-05-2, 268-S-06c-2

**INSTALLER:** LEAVE THIS MANUAL WITH THE WOOD STOVE.

**CONSUMER:** RETAIN THIS MANUAL FOR FUTURE REFERENCE.

# TABLE OF CONTENTS

---

Safety Precautions.....	3
Emissions and Efficiency.....	4
Operating Instructions.....	5
Building Your Fire.....	6
How It Works.....	10
Specifications.....	11
Air Control.....	11
Specifications.....	11
Clearances To Combustibles - 1200-C Insert.....	12
Clearances To Combustibles - 1700-C Insert.....	13
Dimensions - 1200-C Insert.....	14
Dimensions - 1700-C Insert.....	15
Installation.....	16
Removal From Pallet.....	16
Modifications For Installation with 19 <sup>1</sup> / <sub>16</sub> " (484mm) High Lintel.....	16
Masonry Fireplace Installation.....	17
Installation Using A Block-Off Plate For USA Only.....	20
Model 1200-C Brick Placement & Tube Locations.....	22
Model 1700-C Brick Placement & Tube Locations.....	23
C-Cast Ceramic Baffle Installation.....	24
Fan Wiring Diagrams.....	25
Disassembly.....	26
Removal of Cast Top.....	26
Removal of Cast Door.....	26
Removal of Cast Side Panels.....	27
Removal of Cast Side Brackets.....	27
Removal of Surround Panel.....	28
Removal of Lower Front Casting.....	29
Removal of Lower Cast Sides.....	29
Removal of Fan Assembly.....	30
Door Latch Adjustment.....	30
Rating Label.....	31
Parts List.....	32
Parts Diagram.....	33
Notes.....	34
Warranty.....	35
Installation Data Sheet.....	36

# SAFETY PRECAUTIONS

FOR SAFE INSTALLATION AND OPERATION OF YOUR "ENVIRO" WOOD STOVE, PLEASE CAREFULLY READ THE FOLLOWING INFORMATION:

- **Please read this entire manual before you install and use your new woodstove. Failure to follow instructions may result in property damage, bodily injury or even death. Be aware that local Codes and Regulations may override some items in this manual. Check with your local inspector.**
- If this appliance is not properly installed, operated and maintained, a serious house fire could result. Makeshift compromises during installation could also result in a serious house fire.
- HOT WHILE IN OPERATION. KEEP CHILDREN, CLOTHING, AND FURNITURE AWAY. CONTACT MAY CAUSE SKIN BURNS.
- Operate only with the door tightly closed and burn wood directly on the stove hearth. Do not operate if the door glass is broken or a gasket is missing or damaged. Do not alter the combustion air control valves. Dangerous overfiring could occur which could ignite creosote in the chimney or cause a house fire.
- At least 12 square inches (77.4 cm<sup>2</sup>) of fresh outside air should be admitted into the room
- Do not burn coal or charcoal as there is danger of carbon monoxide being produced. DO NOT USE CHEMICAL FLUIDS TO START OR RE-FRESH THE FIRE. DO NOT BURN GARBAGE OR FLAMMABLE FLUIDS SUCH AS GASOLINE, GREASE, NAPHTHA OR ENGINE OIL. Never let the stove become hot enough to get any part red or glowing red.
- Burning wet, unseasoned wood could cause excessive creosote accumulation in the flue pipe. When ignited, it could cause a chimney fire that could result in a serious house fire.
- Do not use grates, irons or any other methods to support or raise the fire up off the hearth of the appliance.
- This unit was tested and listed UL-1482-2010, ULC-S628-93 by Omni-Test Laboratories
- Both the 1200-C & 1700-C Fireplace Inserts are approved for installed into a zero-clearance fireplaces in the U.S. In Canada refer to local building or fire officials for restrictions and installation inspection
- In Canada the existing chimney must be lined to the termination for all masonry installs.
- A chimney connector shall not pass through an attic or roof space, closet or similar concealed space, or a floor, or ceiling.
- Where passage through a wall, or partition of combustible construction is desired, the installation shall conform to CAN/CSA-B365.
- DO NOT CONNECT TO ANY AIR DISTRIBUTION DUCT OR SYSTEM.
- In the event of component failure, only manufacturer specified replacement parts may be used.
- DO NOT CONNECT THIS UNIT TO A CHIMNEY FLUE SERVING ANOTHER APPLIANCE.
- DO NOT INSTALL IN A MOBILE HOME.



# EMISSIONS AND EFFICIENCIES

---

## EMISSIONS AND EFFICIENCY - 1200-B INSERT:

---

### BOSTON 1200

**Rates:** This manual describes the installation and operation of the Enviro Boston 1200 wood heater. This heater meets the 2015 U.S. Environmental Protection Agency's wood emission limits for wood emission limits sold after May 15, 2015. Under specific test conditions this heater has been shown to deliver heat at rates ranging from 11,500-34,000 Btu/hr.

**Efficiency:** 71.6%

## EMISSIONS AND EFFICIENCY - 1700-B INSERT:

---

### BOSTON 1700

**Rates:** This manual describes the installation and operation of the Enviro Boston 1200 wood heater. This heater meets the 2015 U.S. Environmental Protection Agency's wood emission limits for wood emission limits sold after May 15, 2015. Under specific test conditions this heater has been shown to deliver heat at rates ranging from 9,400-32,000 Btu/hr.

**Efficiency:** 75%

### **Stress Lines:**

Stress lines located within the firebox at the secondary air channels may result from the repeated expansion and contraction of metal during regular use. These lines, when narrower than the thickness of a coin, do not compromise the safety or efficiency of the unit and as such do not necessitate repair or replacement.

Similarly, stress lines that may appear on the firebox front due to regular use also do not compromise safety or efficiency of the unit, with the possible exception of the door gasket. In the event that these extend beyond the door gasket, they may have a minor effect on the integrity of the seal and will then be covered by the warranty policy for repair.

**WARNING:** This wood heater needs periodic inspection and repair for proper operation. It is against federal regulations to operate this wood heater in a manner inconsistent with operating instructions in this manual.

**WARNING:** This wood heater has a manufacturer set minimum low burn rate that must not be altered. It is against federal regulations to alter this setting or otherwise operate this wood heater in a manner inconsistent with operating instructions in this manual.

# OPERATING INSTRUCTIONS

---

## **FIRST START**

When first installed, the chimney, firebricks and steel are cold and it usually takes several hours on a fairly high burn for them to become hot and dry enough for the stove to function well. We recommend during the unit's first burn that a door and window are opened to vent the smoke and fumes created from the unit's paint curing. The paint will smell a little for the first burn or two as it cures.

## **DISPOSAL OF ASHES:**

If you let the ashes accumulate two or three inches on the floor they tend to burn themselves up.

Ashes should be placed in a metal container with a tight fitting lid. The closed container of ashes should be placed on a noncombustible floor or on the ground, well away from all combustible materials, pending final disposal. If the ashes are disposed of by burial in soil or otherwise locally disposed, they should be retained in the closed container until all cinders have thoroughly cooled. Other waste shall not be placed in this container.

## **FAN OPERATION:**

All models have been approved for operation with the fans supplied by the manufacturer. On medium or high burns, using a fan will increase the heat transfer slightly. Route the electrical cord along the floor in front of the surround panel. There are cutouts in the castings to tuck the cord under.

1. Plug the fan assembly into a standard three (3) prong grounded electrical receptacle.
2. The fan is controlled by a rotary dial located at the lower left side of the unit. The dial rotation is as follows: OFF>HIGH>LOW
3. If the dial is in any position in the high to low range, the fan will automatically turn on once the stove has reached operating temperature (roughly 25 mins from a cold start). When the unit cools down, the fan temperature sensor will shut the fan off automatically. The fan can also be turned off manually at any time by rotating the dial to the off position.

## **REPLACING THE GLASS:**

Never strike or slam the door, hit the glass or let burning wood rest against it. If the glass cracks when the fire is burning, do not open the door until the fire is out and do not operate the stove again until the glass has been replaced. If the glass is damaged in any way, a factory replacement is required (see "PARTS LIST"). To replace the glass, remove the steel retaining clips and all loose glass. Replace only with Neoceram 5 mm glass 16.61" (422 mm) x 10.63" (270 mm) and wrap the edges with 0.125" (3.2 mm) x 0.5" (13 mm) self-adhesive fiberglass gasket.

Wear gloves when handling damaged glass door assembly to prevent personal injury. When the glass door assembly is being transported, it must be wrapped in newsprint and tape and/or a strong plastic bag.

**The glass must be purchased from an ENVIRO dealer. No substitute materials are allowed.**

## **FIRE EXTINGUISHER AND SMOKE DETECTION:**

All homes with a wood burning stove should have at least one fire extinguisher in a central location known to all in the household. Smoke detectors and carbon monoxide detectors should be installed and maintained in the room containing the stove. If it sounds the alarm, correct the cause but do not deactivate. You may choose to relocate the smoke detection device within the room; **DO NOT REMOVE THE SMOKE OR CARBON MONOXIDE DETECTORS FROM THE ROOM.**

# OPERATING INSTRUCTIONS

---

## **CREOSOTE - ITS FORMATION AND NEED FOR REMOVAL:**

When wood is burned slowly, it may produce tar and other organic vapors, which combine with expelled moisture to form creosote. The creosote vapors condense in the relatively cool chimney of a slow-burning fire. As a result, creosote residue accumulates on the flue lining. When ignited this creosote makes an extremely hot fire. The chimney connector and chimney should be inspected bi-weekly during the heating season to determine if a creosote buildup has occurred. If creosote has accumulated (3mm or more) it should be removed to reduce the risk of a chimney fire.

## **MAINTENANCE:**

At the end of each heating season clean the chimney and the smoke pipe. If soot has accumulated above the top baffle bricks, remove, clean, and then replace them. If a secondary air tube is badly corroded, replace it. Replace worn door gaskets and broken bricks as needed.

**FAILURE TO INSPECT AND CLEAN YOUR CHIMNEY SYSTEM REGULARLY CAN RESULT IN A CHIMNEY FIRE, WHICH COULD DAMAGE THE CHIMNEY OR CAUSE A HOUSE FIRE.**

## **CHIMNEY OR RUN AWAY FIRE:**

1. Call local fire department (or dial 911)
2. Close the draft fully
3. Examine the flue pipes, chimney, attic, and roof of the house, to see if any part has become hot enough to catch fire. If necessary, spray with fire extinguisher or water from the garden hose.
4. Do not operate the stove again until you are certain the chimney and its lining have not been damaged.

## **BUILDING YOUR FIRE:**

---

Proper operation of your stove will help to ensure safe, efficient heating. Please take a few moments to review these simple operating procedures.

**IMPORTANT:** Please be aware when loading your stove that the air tubes in the rear are lower.

### **1. Fuel Selection:**

This stove is designed to burn natural wood only. Higher efficiencies and lower emissions generally result when burning air-dried seasoned hardwoods, as compared to softwoods or too green or freshly cut hardwoods. **DO NOT BURN** the following: treated wood, coal, garbage, solvents, colored papers or trash. Burning these may result in the release of toxic fumes and may poison or render the secondary air tubes ineffective. Burning coal, cardboard or loose paper can produce soot, or large flakes of char or fly ash that can coat the combustor, causing smoke spillage into the room, and rendering the combustor ineffective.

### **2. Building/Maintaining a Fire:**

- a) Open the primary air slide by pulling it all the way to the right.
- b) Place a base of crumpled uncolored newspaper in the bottom of the stove. Lay pieces of kindling on top of the newspaper and light it.

**CAUTION: "Never use gasoline, gasoline-type lantern fuel, kerosene, charcoal lighter fluid, or similar liquids to start or "freshen up" a fire in this heater. Keep all such liquids well away from heater while it is in use.**

- c) As the kindling begins to burn, add several larger pieces of wood until the fire is burning well. At this point, regular size logs may be added.

**CAUTION: Never allow the fire to rest directly on the glass. Space the logs at least one inch off the glass to allow for proper air flow.**

**NOTE:** Until the fire is burning well, leave the air controls fully open.

# OPERATING INSTRUCTIONS

---

- d) Regulate the heat output of the stove by adjusting the air controls to allow a larger fire and vice versa. A short period of experimentation with the control settings will allow you to regulate the heat output to keep your home comfortable.

**Do not use a grate or elevate the fire. Build wood fire on the stove firebox hearth floor.**

### 3. Refueling the Stove:

Use a long pair of gloves (barbecue gloves) when feeding the fire because these stoves burn at the front. They are clean and efficient but they are also very hot and gloves are useful. Keep a small steel shovel and whisk nearby for moving a log or lifting a fallen ember and for keeping the hearth clean.

- a) Before attempting to add fuel to the stove, OPEN the damper control fully by pulling it all the way out. This allows the chimney to carry away the additional smoke, which occurs when the door is open.

b) **DO NOT OVERLOAD THE STOVE.** Normally, three or four logs will provide heat for several hours. Never operate this stove where portions glow red hot. Using more than five logs at a time can cause overfiring. Keep logs a few inches from the lowest point of the top of the firebox. If any logs are touching the tubes in the top of the firebox, you can damage the air tubes. Overloading the stove can cause damage to the firebox and air tubes and will void the warranty.

c) **DO NOT OVERFIRE.** If the heater or chimney connector glows, you are overfiring. If the stove top temperatures exceed 550°F, you are overfiring. Overfiring your stove will void the warranty.

d) **WHAT IS OVERFIRING?** Overfiring is when the stove is generating too much heat in the firebox, causing parts within your stove to glow red and warp. To spot overfiring, place a thermometer on the stove top. If the stove top temperatures exceed 550°F, you are overfiring. Another way to spot overfiring is if the heater or chimney connector glows.

e) **CAUTION:** DO NOT PLACE FUEL OR COMBUSTIBLE MATERIAL WITHIN SPACE HEATER INSTALLATION CLEARANCES OR WITHIN THE SPACE REQUIRED FOR CHARGING AND ASH REMOVAL. LOGS SHOULD BE KEPT IN A BIN OR CONTAINER TO REDUCE THE RISK OF LOGS ROLLING INTO THE UNIT'S CLEARANCES.

f) **HOW TO AVOID OVERFIRING:** To avoid overfiring, do not overfill your firebox. Usually a maximum of four logs at a time is sufficient enough to avoid overfiring. Keeping stove top temperatures under 550°F will also prevent overfiring.

g) **KEEP THE ASH LIP CLEAR OF EMBERS AND ASH.** If the door is closed with debris in the way, the door gasket seal could be compromised.

### 4. For Maximum Efficiency:

When the stove is hot, load it fully to the top of the door opening and burn at medium low settings. When the fuel is mostly consumed, leaving a bed of red coals, repeat the process. Maximum heat for minimum fuel occurs when the stove top temperature is between 250°F (120°C) and 550°F (290°C). The most likely causes of dirty glass are: not enough fuel to get the stove thoroughly hot, burning green or wet wood, closing the draft until there is insufficient air for complete combustion, or a weak chimney draw. Indeed, the cleanness of the glass is a good indicator of the stove operating efficiently.

#### Helpful Hints Worth Repeating

##### 1. Helpful advice on the correct way to start your fire.

- a) You will need small pieces of dry wood, called kindling, and paper. Use only newspaper or paper that has not been coated or had other materials glued or applied to it. Never use coated (typically advertising flyers) or coloured paper.
- b) Always open the door of the wood stove slowly to prevent suction and drawing smoke into the room.
- c) Crumple several pieces of paper and place them in the center of the firebox and directly onto the firebricks of the wood stove. Never use a grate to elevate the fire.

# OPERATING INSTRUCTIONS

---

- d) Place small pieces of dry wood (kindling) over the paper in a “teepee” manner. This allows for good air circulation, which is critical for good combustion.
- e) Light the crumpled paper in 2 or 3 locations. Note: It is important to heat the air in the stovepipe for draft to start.
- f) Fully open the air controls of the wood stove and close the door until it is slightly open, allowing for much needed air to be introduced into the firebox. Never leave the door fully open, as sparks from the kindling may fly out of the stove, causing damage or injury. As the fire begins to burn the kindling, some additional kindling may be needed to sustain the fire. DO NOT add more paper after the fire has started.
- g) Once the kindling has started to burn, add some smaller pieces of seasoned, dry firewood. Note: Adding large pieces at the early stages will only serve to smother the fire. Continue adding small pieces of seasoned dry firewood, keeping the door slightly open until each piece starts to ignite. Remember to always open the door slowly between placing wood into the fire.
- h) Once the wood has started to ignite and the smoke has reduced, close the wood stove door fully. The reduction of smoke is a good indication that the draft in the chimney has started and good combustion is now possible. Larger pieces of seasoned, dry firewood can now be added when there is sufficient space in the firebox. Adjust the air control setting to desired setting. Note: The lower the air control setting, the longer the burn time of your firewood.

## **2. What type of wood is best to use as firewood?**

Both hardwood and softwood burn well in this stove. Both woods contain about 8,000 BTU/lb (18,570 KJ/Kg), but hardwood is generally more dense, will weigh more per cord, and burns a little slower and longer. Cutting firewood so that it will fit horizontally, front to back, makes it easier loading and less likely for the fuel to roll on the glass. Except for a cold start, there is no need to crisis-cross the logs. Ideal length for the logs used in the 1200-C would be about 16" (381 mm) but it can burn pieces up to 18" long. Ideal length for the logs used in the 1700-C would be about 18" (381 mm) but it can burn pieces up to 20" long logs. Burn only dry, seasoned wood. It produces more heat and less soot or creosote. Freshly cut wood has about 50% moisture. A 10 pound (4.5 Kg) log contains 5 pounds (2.3 Kg) of water. To season firewood, split and stack it so that air can get to all parts of the wood. Burn beach wood only if its salt content has been washed away in a season of rain and then the wood dried. To prevent smoke spillage when refueling, open the door slowly.

## **3. What does dry, seasoned wood mean?**

Wood that has been dried for a period of one year in a well-ventilated and sheltered area would be considered dry, seasoned wood. Wood from slow-growing trees is generally considered better than wood from fast-growing trees. To season firewood, split and stack it so that air can get to all parts of the wood.

## **4. Will following the above-listed steps for starting a fire mean perfect results every time?**

The quick answer is 'most of the time'. There are many variables that may affect your success when starting a fire. Most of those variables and how to deal with them will be learned through experience. Your ability to start a good fire will significantly increase with time and patience. Some of the reasons for poor stove performance will be covered in the next section of these instructions.

## **5. Why can't I get the fire lit?**

Damp or wet wood and poor drafts are the main reasons for poor results in starting a fire. Always use dry,

# OPERATING INSTRUCTIONS

---

seasoned wood for your fire. Even wood dried for two years will be difficult to ignite if it has become wet.

## 6. Is it normal for soot to cover the glass at the beginning of a fire?

Your stove has been built with an air-wash system that will help keep the glass clear when the firebox has reached a good operating temperature and has a good draft. Normally, a hot stove will keep the glass clean, but if you must clean the glass, use a soft cloth with no abrasive and clean only when the unit is cold. Cold firebox temperature and poor draft cause sooting of the glass. Once the firebox temperature and the draft increase, the soot will burn off. **Do not use abrasive cleaners on glass.**

## 7. What is draft?

Draft is the ability of the chimney to exhaust or draw smoke produced during the normal combustion process. Too much draft may cause excessive temperatures in the appliance and may damage the appliance. Inadequate draft may cause backpuffing or "plugging" of the chimney. There is a certain amount of draft that is required to allow for your stove to function at its' highest efficiency. A water column gauge can be used to reference this amount.

## 8. What can cause a poor draft?

The most common factors for poor draft are:

- a) Air supply
  - b) Environmental conditions
  - c) Cold chimney temperature
  - d) Poor chimney installation and maintenance
  - e) Atmospheric pressure
- a) Air supply – Inside the home, normal household appliances such as clothes dryers and forced-air furnaces compete for air, resulting in air starvation to the fire. This creates a condition in the house known as negative pressure. When a house experiences negative pressure, the combustion gases can be drawn from the chimney and into the house. This condition is commonly referred to as down-drafting. Increased amounts of insulation, vinyl windows, extra caulking in various places and door seals can all keep heat in but may also make a home too airtight. An easy way to stop negative pressure in a home is to crack a window in the room containing the stove.
  - b) Environmental Conditions - High trees, low-lying house location such as in a valley, tall buildings or structures surrounding your house and windy conditions can cause poor draft or down-drafting.
  - c) Cold Chimney Temperature - Avoid cold chimney temperatures by burning a hot fire for the first fifteen to forty minutes, being careful not to over-fire the stove. If any part of the chimney or parts of the stove start to glow, you are over-firing the stove. Where possible, install a temperature gauge on the chimney so temperature drops can be seen.
  - d) Chimney Installation and Maintenance - Avoid using too many elbows or long horizontal runs. Too short a chimney can cause difficult start-up, dirty glass, back smoking when door is open, and even reduced heat output. Too tall a chimney may prompt excessive draft, which can result in very short burn times and excessive heat output. If in doubt, contact a chimney expert and/or chimney manufacturer for help. Clean chimney, rain caps and especially the spark arrestor regularly, to prevent creosote build-up, which will significantly reduce chimney draw and possibly a chimney fire.

**Note:** These instructions are intended as an aid and do not supercede any local, provincial or state requirements. Check with officials or authorities having jurisdiction in your area.

## 9. How can I reduce the visible emissions?

If all of these steps are followed, there should be no visible emissions.

# OPERATING INSTRUCTIONS

## How It Works:

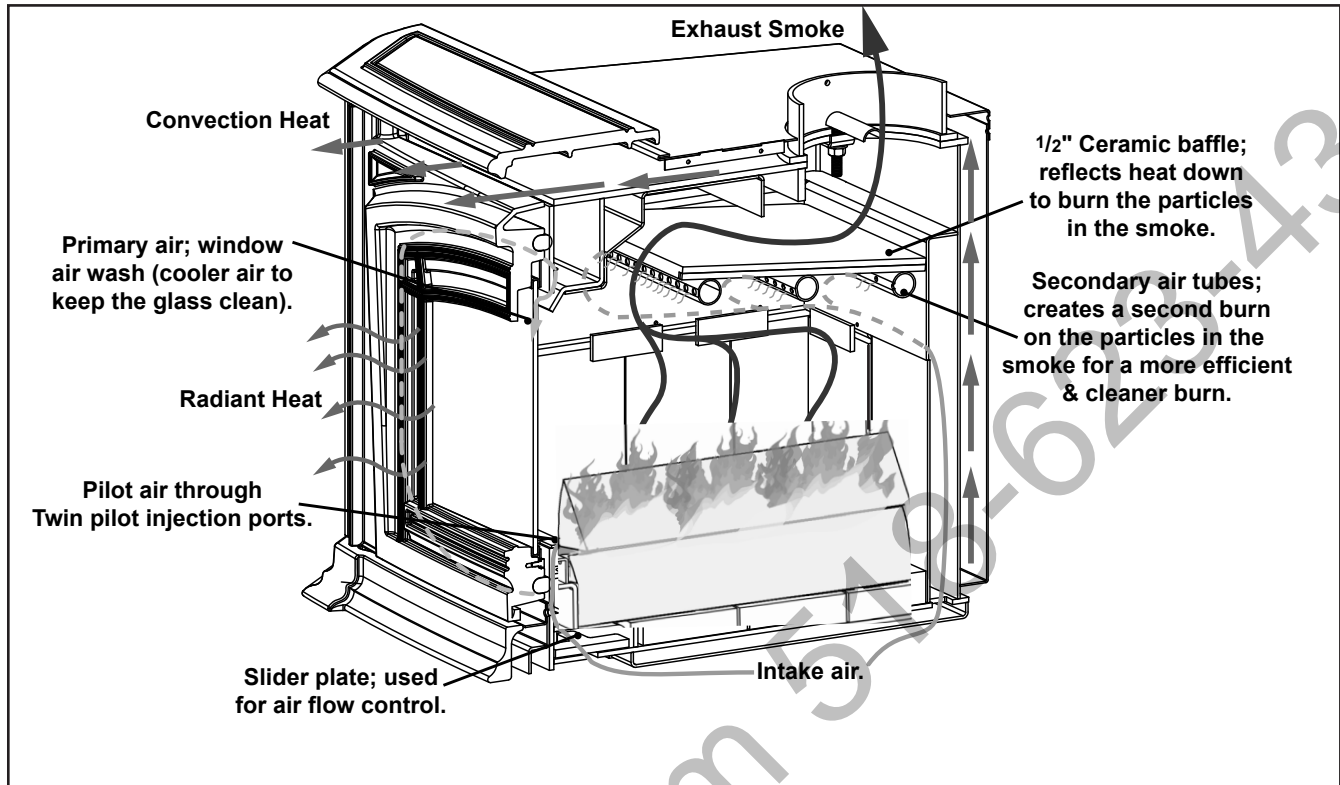

Figure 2: 1200-C Air Flow Path.

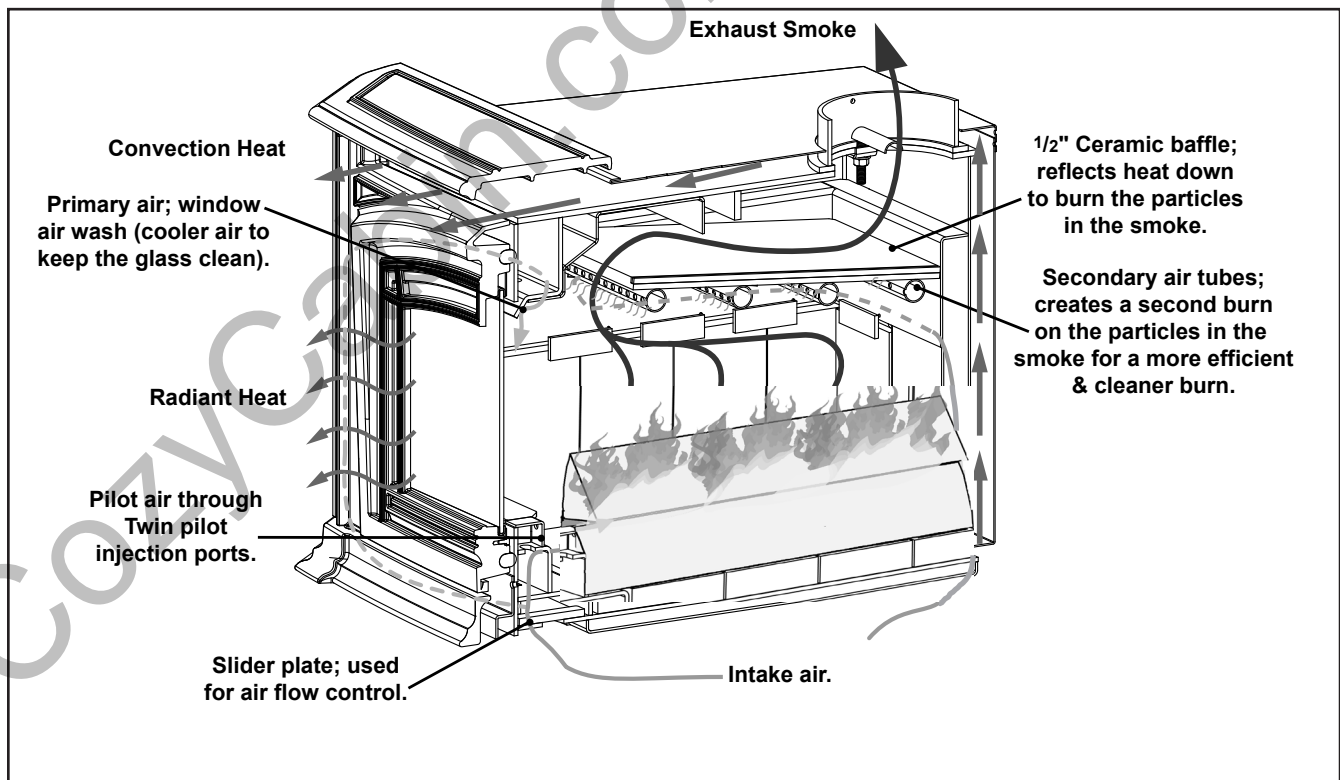

Figure 3: 1700-C Air Flow Path.

# SPECIFICATIONS

## AIR CONTROL:

The primary air is controlled by the rod located on the right side of the unit. To increase your air, pull the rod out and to decrease, push the rod in. All the units have a secondary air that flows through the tubes at the top of the firebox, just below the baffles.

Pull this control all the way out when first starting the stove. Once the fire has been established you may adjust this control to set the burn rate of the fire. For optimal efficiency, use a low to medium setting. If this damper is closed at first start-up, the fire will burn very slowly and could soot the appliance.

When shutting down the stove, fully open the air control. This allows the chimney temperatures to remain as high as possible for as long as possible. Cold chimney temperatures create creosote.

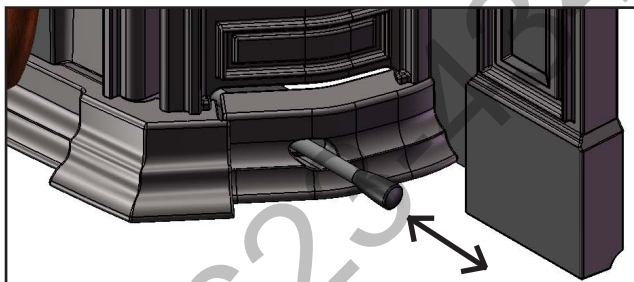

**Figure 4: Air Control Rod.**

## SPECIFICATIONS:

**Table 1: 1200-C & 1700-C General Information.**

Model	1200 Insert	1700 Insert
Width x Depth	27 <sup>3</sup> / <sub>4</sub> " x 22" (705 mm x 559 mm)	27 <sup>3</sup> / <sub>4</sub> " x 26.5" (705 mm x 673 mm)
Height of body	19 <sup>1</sup> / <sub>16</sub> " (484 mm) or 19 <sup>9</sup> / <sub>16</sub> " (497 mm)	
Fire box size (depth x width x height)	16.1" x 18.25" x 11.15" (409 mm x 464 mm x 283 mm)	20.65" x 18.25" x 11.95" (525 mm x 464 mm x 304 mm)
Capacity	1.85 feet <sup>3</sup> (0.0526 meter <sup>3</sup> )	2.5 feet <sup>3</sup> (0.0708 meter <sup>3</sup> )
* Approximate heating area	2200 feet <sup>2</sup> (205 meter <sup>2</sup> )	3000 feet <sup>2</sup> (280 meter <sup>2</sup> )
**E.P.A. output rating	11,479 to 34,196 BTU/hour (3,361 to 10,013 watt)	9,425 to 31,780 BTU/hour (2,760 to 9,306 watt)
*Duration on low burn	6 -10 hours	8 - 12 hours
Weight with packaging	335 lb (151.95 Kg)	390 lb (176.90 Kg)
E.P.A. Emissions	3.3 grams/hour (0.116 oz/hour)	4.48 grams/hour (0.158 oz/hour)
Surround Panel		
Standard (width x height)	49.25" x 30.75" (1251 mm x 781 mm)	
Rating Label Location	Side of Unit; Behind Right Shroud	

# SPECIFICATIONS

## CLEARANCES TO COMBUSTIBLES - 1200-C INSERT:

**Table 2: 1200-C Insert Clearance to Combustibles.**

A	Minimum clearance to an unshielded side wall	10" (254 mm)
B	Minimum clearance to an unshielded 8" (203 mm) mantel	21" (533 mm)
C	Minimum top facing (protruding ¾" [19 mm]) clearance	17½" (445 mm)
D	Minimum side facing (protruding ¾" [19 mm]) clearance	1" (25 mm)
E	† From front of door opening to edge of floor protection	USA 16" (406 mm) CND 18" (450 mm)
F	† From side/back of unit to edge of floor protection	USA 6" (152 mm) CND 8" (200 mm)

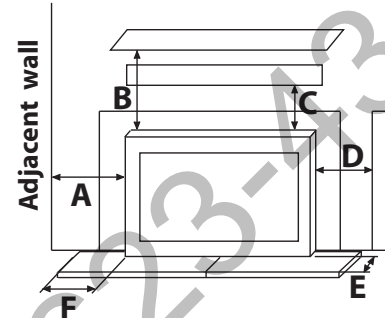

**† FLOOR PROTECTION:**

If unit is raised 0" - 2" (0mm-51mm); 1" (25mm) non-combustible material with k value = 0.84 or equivalent.  
 If unit is raised 2" - 8" (51mm-203mm); ½" (13mm) non-combustible material with k value = 0.84 or equivalent.  
 If unit is raised greater than 8" (203 mm) or more; any non-combustible material can be used.

**Table 3: Reduction in (B) Minimum Clearance from 1200-C to 8" (203 mm) Mantel.**

Type of protection	Modified Clearance
A minimum of .013" (0.33mm) sheet metal spaced out 1" (25mm) by non-combustible spacers.	10½" (267 mm)
Ceramic tiles, or equivalent non-combustible material on non-combustible supports and spaced out 1" (25mm) by non-combustible spacers.	14" (357 mm)
Ceramic tiles, or equivalent non-combustible material on non-combustible supports with a minimum of .013" (0.33mm) sheet metal spaced out 1" (25mm) by non-combustible spacers.	10½" (267 mm)

**NOTES:**

- (1) Mantel protection must have at least 3" (75mm) edge clearance on all sides, except as provided in Note 4.
- (2) If an adhesive is used to support non-combustible material, it shall not lose adhesive qualities at temperatures likely to be encountered and shall not contribute a significant combustible load.
- (3) Heat shield mounting hardware attached to combustible materials must be placed at the lateral extremities of the shield.
- (4) Minimum clearance to unprotected walls and ceilings must be maintained.
- (5) Clearances may only be reduced with shielding acceptable to the local authority.

**Table 4: 1200-C Insert Minimum Fireplace Size.**

	Masonry	Zero Clearance
Minimum Depth	14½" (368 mm)	15" (381 mm)
Minimum Width at back of fireplace	22¾" (568 mm)	23" (584 mm)
Minimum Width at front of fireplace	32" (813 mm)	32¼" (819 mm)
Minimum Height	19¼" (489 mm)** or 19¾" (502 mm)	20" (508 mm)

\*\* If the masonry lintel height is only 19¼" (489 mm) to 19¾" (502 mm) refer to INSTALLATION - MODIFICATIONS FOR INSTALLATION WITH 19¼" (489 mm) HIGH LINTEL - INSERT

# SPECIFICATIONS

## CLEARANCES TO COMBUSTIBLES - 1700-C INSERT:

**Table 5: 1700-C Insert Clearance to Combustibles.**

A	Minimum clearance to an unshielded side wall	10" (254 mm)
B	Minimum clearance to an unshielded 8" (203 mm) mantel	24" (610 mm)
C	Minimum top facing (protruding ¾" [19 mm]) clearance	19½" (495 mm)
D	Minimum side facing (protruding ¾" [19 mm]) clearance	1" (25 mm)
E	† From front of door opening to edge of floor protection	USA 16" (406 mm) CND 18" (450 mm)
F	† From side/back of unit to edge of floor protection	USA 6" (152 mm) CND 8" (200 mm)

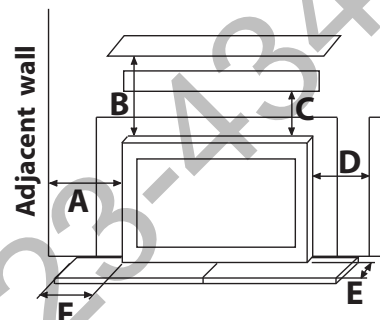

**† FLOOR PROTECTION:**

If unit is raised 0" - 2" (0mm-51mm); 1" (25mm) non-combustible material with k value = 0.84 or equivalent.  
 If unit is raised 2" - 8" (51mm-203mm); ½" (13mm) non-combustible material with k value = 0.84 or equivalent.  
 If unit is raised greater than 8" (203 mm) or more; any non-combustible material can be used.

**Table 6: Reduction in (B) Minimum Clearance from 1700-C to 8" (203 mm) Mantel.**

Type of protection	Modified Clearance
A minimum of .013" (0.33mm) sheet metal spaced out 1" (25mm) by non-combustible spacers.	12" (305 mm)
Ceramic tiles, or equivalent non-combustible material on non-combustible supports and spaced out 1" (25mm) by non-combustible spacers.	16⅛" (408 mm)
Ceramic tiles, or equivalent non-combustible material on non-combustible supports with a minimum of .013" (0.33mm) sheet metal spaced out 1" (25mm) by non-combustible spacers.	12" (305 mm)

**NOTES:**

- (1) Mantel protection must have at least 3" (75mm) edge clearance on all sides, except as provided in Note 4.
- (2) If an adhesive is used to support non-combustible material, it shall not lose adhesive qualities at temperatures likely to be encountered and shall not contribute a significant combustible load.
- (3) Heat shield mounting hardware attached to combustible materials must be placed at the lateral extremities of the shield.
- (4) Minimum clearance to unprotected walls and ceilings must be maintained.
- (5) Clearances can be reduced with shielding acceptable to the local authority.

**Table 7: 1700-C Insert Minimum Fireplace Size.**

	Masonry	Zero Clearance
Minimum Depth	19" (483 mm)	19½" (495 mm)
Minimum Width at back of fireplace	22⅜" (568 mm)	23" (584 mm)
Minimum Width at front of fireplace	32" (813 mm)	32¼" (819 mm)
Minimum Height	19¼" (489 mm)** or 19¾" (502 mm)	20" (508 mm)

\*\* If the masonry lintel height is only 19¼" (489 mm) to 19¾" (502 mm) refer to INSTALLATION - MODIFICATIONS FOR INSTALLATION WITH 19¼" (489 mm) HIGH LINTEL - INSERT

# SPECIFICATIONS

## DIMENSIONS - 1200-C INSERT:

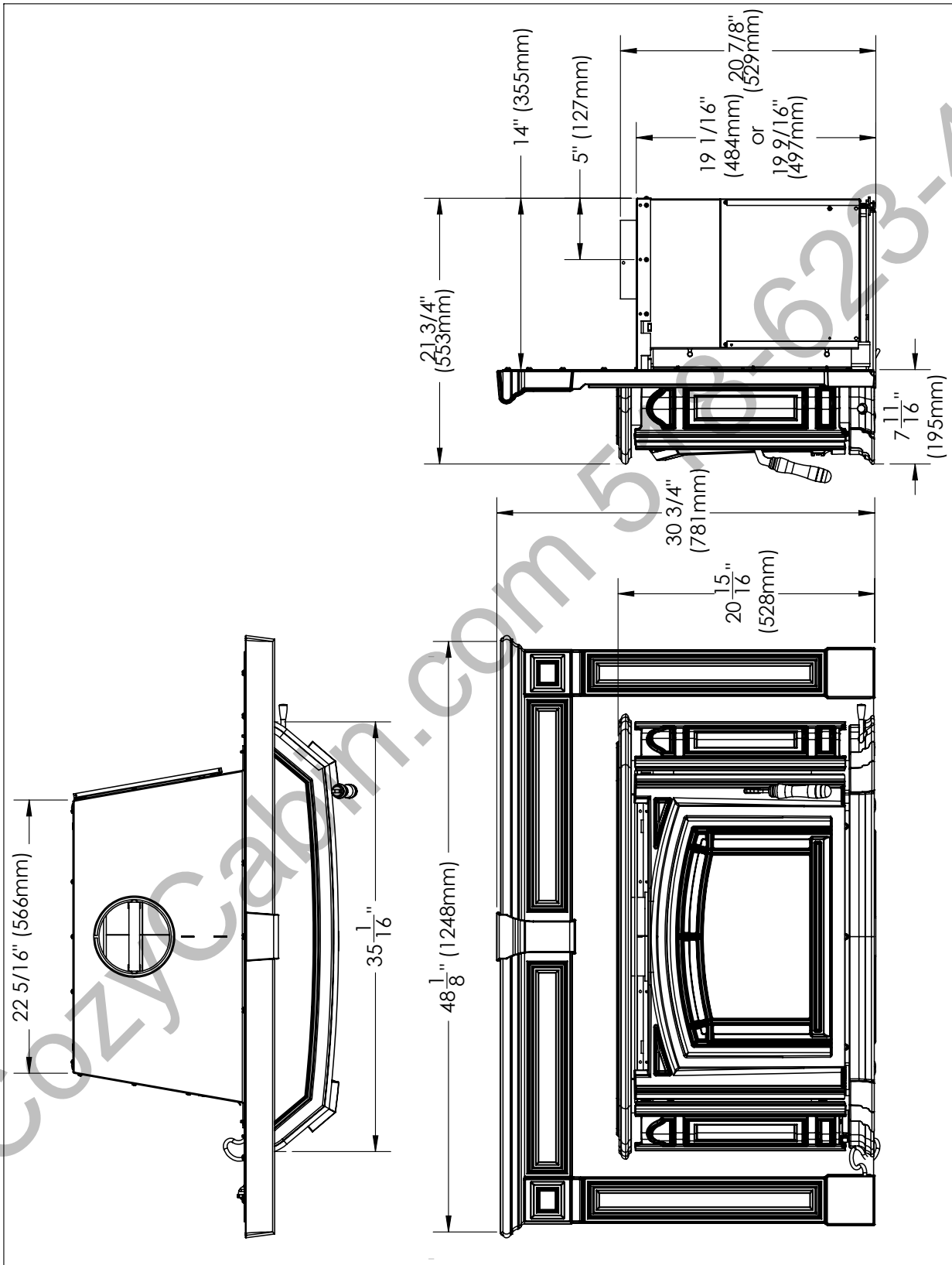

Figure 5: 1200-C Insert Dimensions.

# SPECIFICATIONS

## DIMENSIONS - 1700-C INSERT:

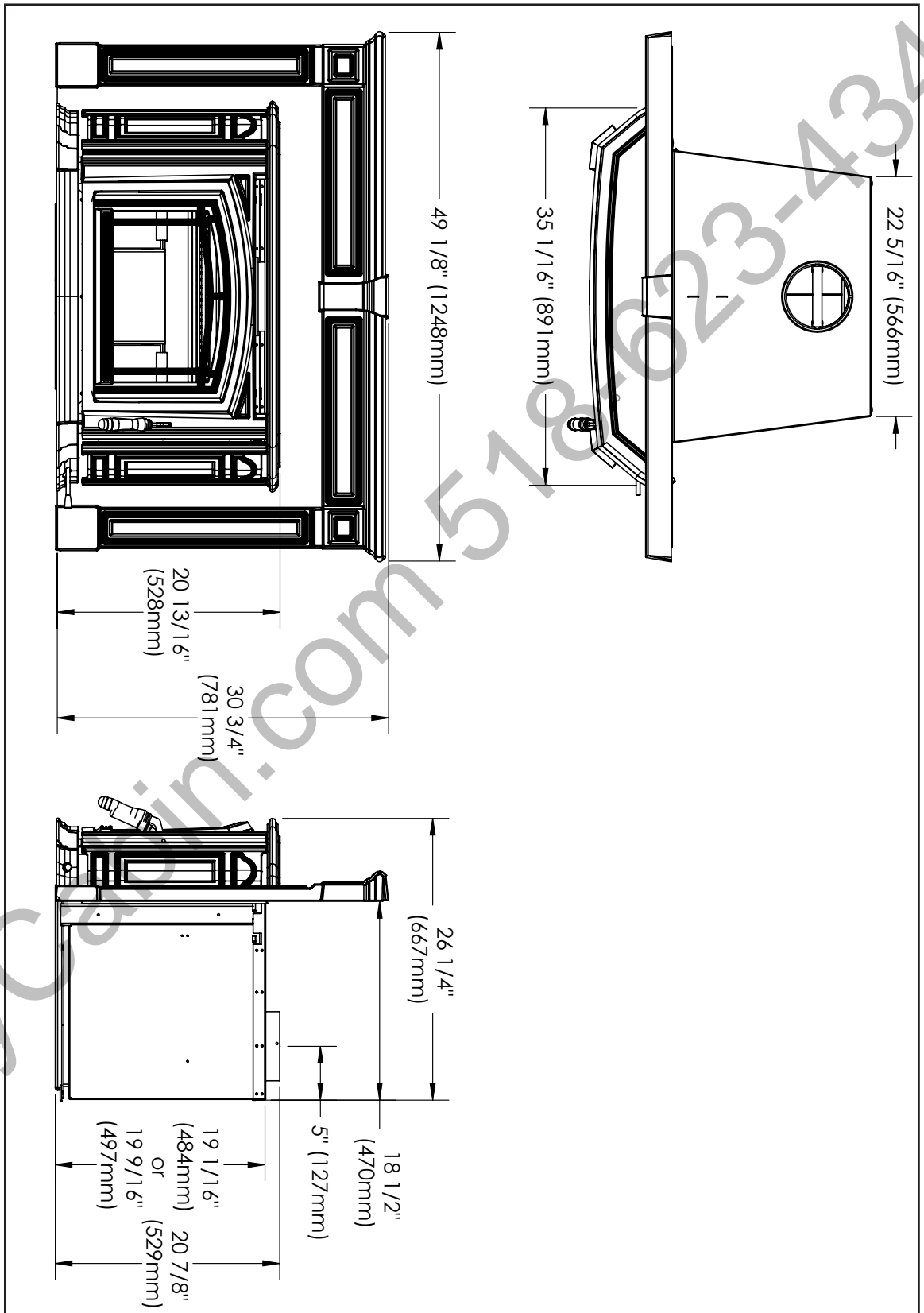

Figure 6: 1700-C Insert Dimensions.

# INSTALLATION

Failure to follow these instructions carefully could cause personal injury or property damage.

## REMOVAL FROM PALLET:

- Remove the bricks from the unit before starting.
- Remove the two lag bolts (shown in Figure 7) that secure the unit to the pallet from inside the firebox.
- Remove the shipping bracket at the rear of the unit.

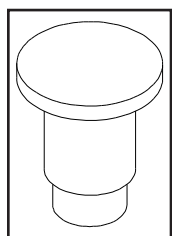

Figure 8:  
Rivet.

**Note:** Before the bricks are installed, rivets (Figure 2) must be placed in the two (2) holes (shown in Figure 8) in the firebox that lag bolts came out of. This is done to make unit burn more efficiently.

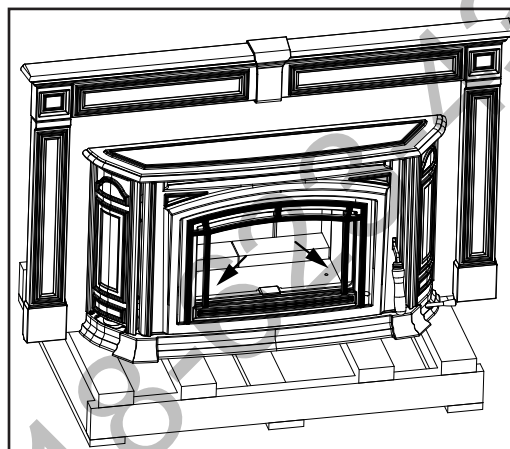

Figure 7: Bolts to remove.

## MODIFICATIONS FOR INSTALLATION WITH 19<sup>1</sup>/<sub>16</sub>" (484MM) HIGH LINTEL:

The Boston has a factory height of 19<sup>9</sup>/<sub>16</sub>" (497mm) and it can be reduced to 19<sup>1</sup>/<sub>16</sub>" (484mm) by modifying the unit and the surround panel.

1. Remove the thirteen T-20 screws holding the cabinet top in place (refer to Figure 8).
2. Remove the cabinet top and flip it onto its top.
3. Remove the Air Deflector (shown in Figure 9) by removing the two (2) T-20 screws.
4. Re-install the cabinet top onto the unit. The screw holes along the top of the unit should now line up with the top set of holes on the cabinet top.

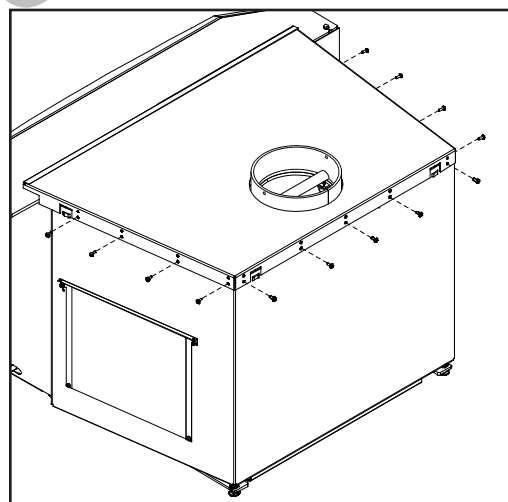

Figure 9: Removing Cabinet Top from Unit.

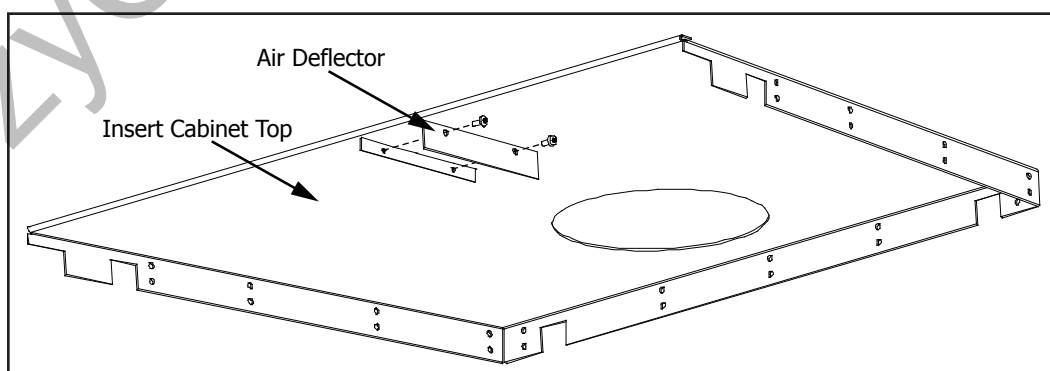

Figure 10: Removing Air Deflector onto Cabinet Top.

# INSTALLATION

## MASONRY FIREPLACE INSTALLATION:

**Unless you are experienced, we recommend installation by your dealer or a professional installer.**

Install only in a masonry fireplace with a good-condition chimney at least 15 ft (4.6 m) high, both of which have been constructed in accordance with the building code. Refer to Tables 4 and 7 for minimum masonry fireplace dimensions. Be sure the fireplace and chimney are clean and sound without any cracks or loose mortar. Do not remove any bricks or mortar from the fireplace.

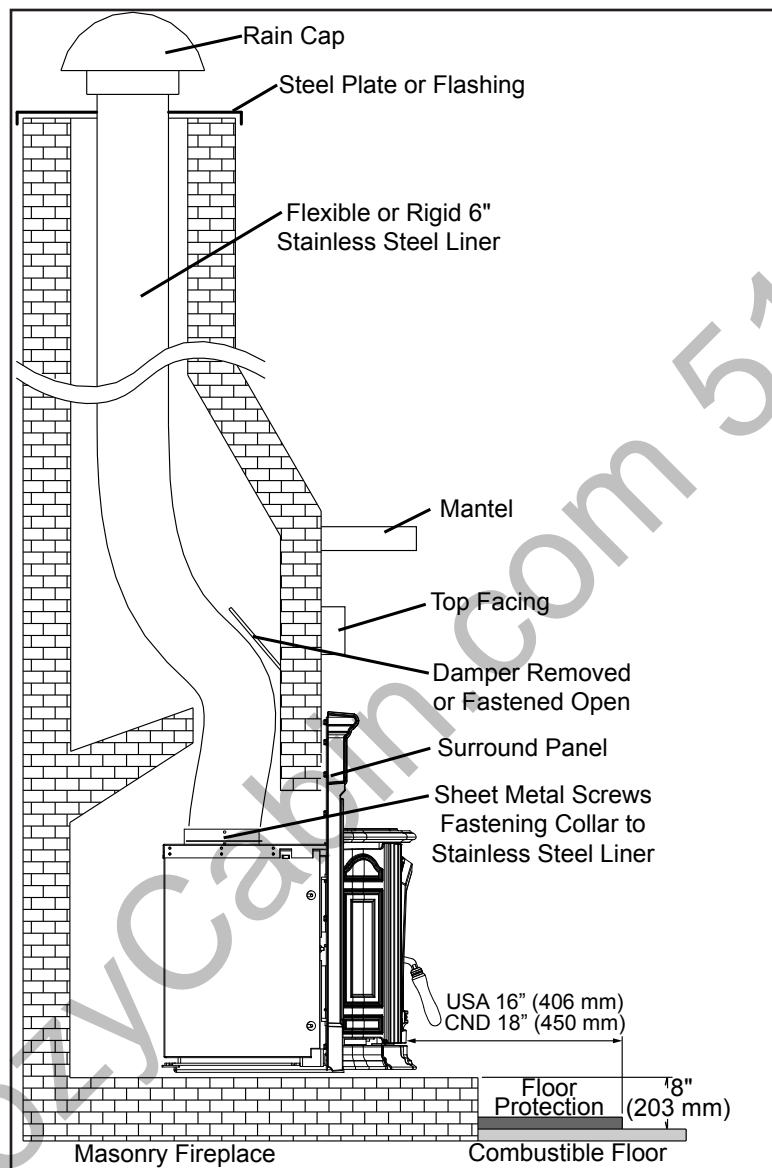

**Figure 11: Insert Installation into existing fireplace with hearth.**

If there is a combustible floor in front of the masonry fireplace, the fireplace insert must be 8" (203 mm) above the combustible floor, and floor protection must be provided 18" (457 mm) in front of the fireplace insert and 8" (203 mm) to each side of the unit. Refer also to SPECIFICATIONS - CLEARANCES TO COMBUSTIBLES - 1200-C INSERT and SPECIFICATIONS - CLEARANCES TO COMBUSTIBLES - 1700-C INSERT.

**1.** Remove any fireplace damper or fasten in a permanent open position.

**2. (IN CANADA)** The stove is vented with a 6" stainless steel liner that goes directly to the top of the chimney and is covered with a rain cap. The chimney top is sealed with a flashing or steel plate that supports the weight of the chimney liner. The installation must conform to the liner's manufacturer's instructions.

This fireplace must be installed with a continuous liner of 6" diameter (CANADA ONLY) extending from the fireplace insert to the top of the chimney. The chimney liner must conform to the Class 3 requirements of CAN/ULC-S635 Standard for Lining Systems for Existing Masonry or Factory-Built Chimneys and Vents, or CAN/ULC-S640 Standard for Lining Systems for New Masonry Chimneys.

**(IN U.S.A.)** The appliance when installed, must follow local building codes, in the absence of local building codes, with the current NFPA 211 Standard for Chimneys, Fireplaces, Vents, and Solid Fuel-Burning Appliances.

# INSTALLATION

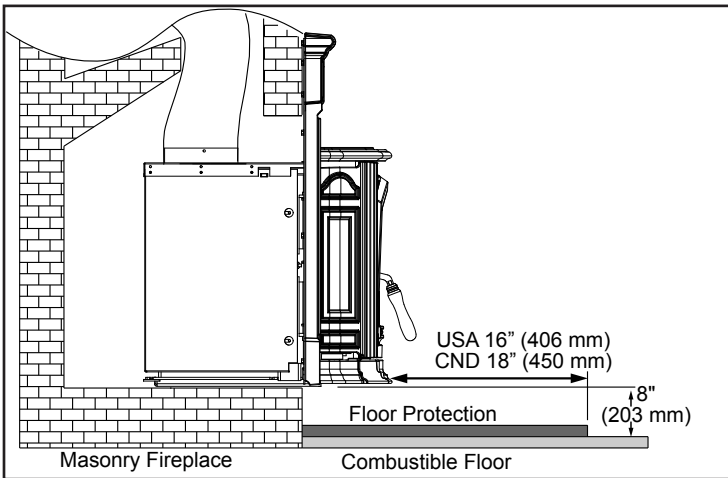

**Figure 12: Insert Installation into existing fireplace without hearth.**

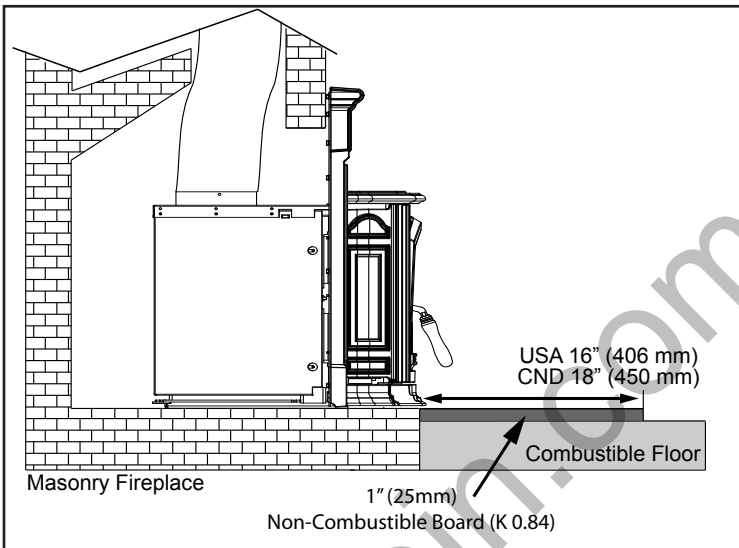

**Figure 13: Insert Installation into existing floor level masonry fireplace.**

The flue collar is removable for installations into fireplaces with low openings.

- a) Remove the rear two (2) secondary air tube and C-Cast Ceramic Baffles, if installed (see C-CAST CERAMIC BAFFLE INSTALLATION). Remove the secondary air tubes by placing a screwdriver (any style except flat head) into one of the air holes and tapping it with a hammer/mallet to the left.
- b) Unscrew the two (2) nuts on top of the inside of the firebox, using a  $\frac{9}{16}$ " wrench or socket (see Figure 14). The Flue Collar Clamps will slide off the bolts.
- c) Pull the removable flue collar off the top of the unit.
- d) Attach the flue collar to the venting pipe using sheet metal screws.
- e) Push the unit into place while trying to keep the collar attached to venting close to the opening on the top of the unit.

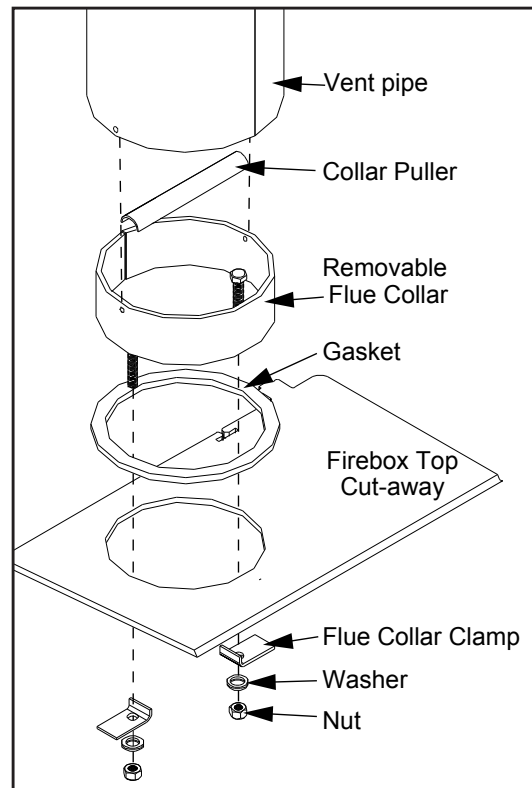

**Figure 14: Attaching removable flue collar.**

- f) Place the Collar Puller, over the two bolts of the Flue Collar and pull it into place (see Figure 14). Ensure that the bolts are to the left and right of the hole. If they are not, the front secondary air tube will need to be removed in order to install or remove the C-Cast Ceramic Baffles.
  - g) Slide the Flue Collar Clamps and washers over the bolts, and screw the nuts back onto the bolts.
  - h) Re-install C-Cast Ceramic Baffles and the rear two (2) secondary air tube (see C-CAST CERAMIC BAFFLE INSTALLATION).
- 3.** There are four (4) leveling legs (shown in Figure 16), two (2) on each side, one at the back and one at the front of the unit. Adjust the legs using a  $\frac{3}{8}$ " wrench to ensure the unit is stable.

# INSTALLATION

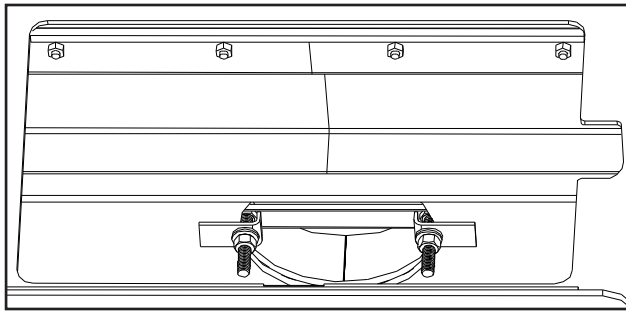

**Figure 15: Removable flue collar in place.**

4. Screw or nail the provided metal plate with the wording "THIS FIREPLACE HAS BEEN ALTERED TO ACCOMMODATE A FIREPLACE INSERT AND SHOULD BE INSPECTED BY A QUALIFIED PERSON PRIOR TO THE RE-USE AS A CONVENTIONAL FIREPLACE." to the inside of the fireplace.

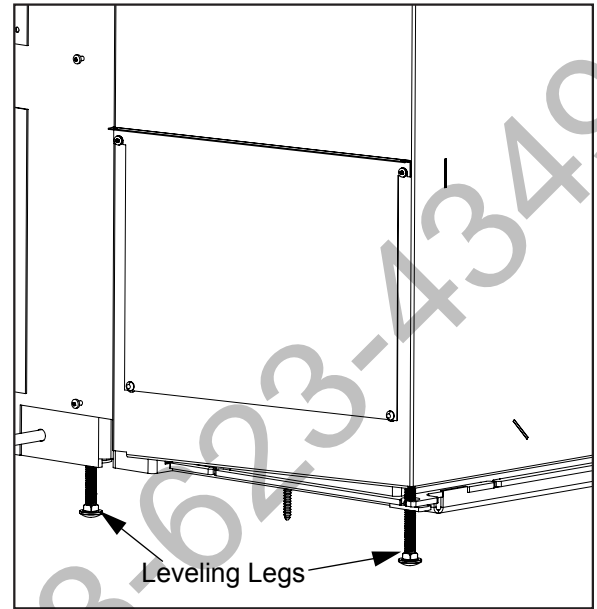

**Figure 16: Leveling legs.**

## **SURROUND PANEL SEALED INSTALLATION FOR USA ONLY:**

**Note:** Though this is an allowable installation, we do not recommend it because of the possibility of poor draft, and therefore poor stove performance.

Before starting this type of installation refer to INSTALLATION - MASONRY FIREPLACE INSTALLATION - INSERT for additional information. For clearances refer to SPECIFICATIONS - CLEARANCES TO COMBUSTIBLES - 1200-C INSERT and SPECIFICATIONS - CLEARANCES TO COMBUSTIBLES - 1700-C INSERT.

1. Before the face plate is installed onto the unit, glue a 6" (150mm) wide R20 fiberglass insulation strip around the perimeter of the back of the panels using RTV silicon or stove gasket cement. When the face plate is installed onto the unit the insulation must overlap the fireplace opening to form a seal between the masonry fireplace and the unit's face plate. Let the silicon or cement dry.
2. To make the installation of the surround panel onto the unit easy have the unit 6" (150mm) out from the fireplace,
3. Push the insert into the fireplace, allowing the insulation to form a seal between the panels and the fireplace. Tuck any exposed insulation behind the face plate.

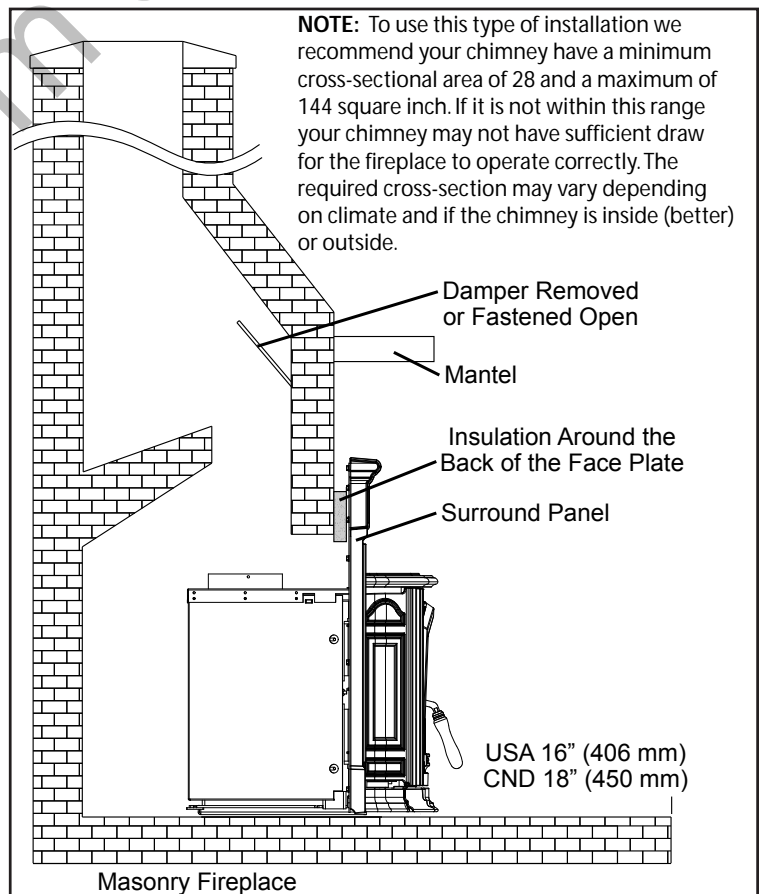

**Figure 17: Installation with Surround Sealed.**

# INSTALLATION

## INSTALLATION USING A BLOCK-OFF PLATE FOR USA ONLY:

If this unit is to be installed into a masonry fireplace or a zero-clearance fireplace with a direct connection you must install a non-combustible seal-off device such as a block-off plate or damper adapter. By installing a block-off plate you seal the chimney, ensuring that no smoke enters the home and sealing the chimney to encourage draft. To construct a block-off plate follow the below steps.

Before starting this type of installation refer to **INSTALLATION - MASONRY FIREPLACE INSTALLATION - INSERT** for additional information. For clearances refer to **SPECIFICATIONS - CLEARANCES TO COMBUSTIBLES - 1200-C INSERT** and **SPECIFICATIONS - CLEARANCES TO COMBUSTIBLES - 1700-C INSERT**. See Figure 20 and 21 for examples of a masonry fireplace and a zero-clearance fireplace with a direct connection.

1. Determine where the block-off plate will be installed; above the top of the firebox (it must be high enough to easily install the connection pipe) but below the damper area. Look for a location that is level and in an area where the plate can be mounted easily.

The measurement that will be needed are as followed (refer to Figure 17 and 18):

- A - The width at the front of the firebox at the height where the block-off plate will be installed.
- B - The width at the back of the firebox at the height where the block-off plate will be installed.
- C - Then depth of the block-off needed (the distance between A and B).
- D - The distance of the center of the flue to the front of the fireplace opening. Refer to Step 3.

**NOTE:** In general masonry fireplaces have square fireboxes while zero-clearance (metal) fireplaces have domed firebox tops. Therefore zero-clearance block-off plates may be more difficult to install. Insulation may be used around the edges to simplify sealing the plate.

2. Create a cardboard template of the dimensions with 2" (51 cm) wide flanges on each side. These flanges will be used to mount the block-off plate to the inside of the firebox. Bend the flanges downwards on the template and place it inside the fireplace. Continue on if the template fits correctly in its planned location. If the template does not fit, make a new template with the required corrections until it does fit correctly.
3. With the template in place, mark the location for the center of the flue pipe when the unit is in place. If installing a 1200-C the distance will be approximately 8 $\frac{1}{4}$ " or 9 $\frac{15}{16}$ " back from the fireplace opening. If installing a 1700-C the distance will be approximately 12 $\frac{3}{4}$ " or 14 $\frac{7}{16}$ " back from the fireplace opening. Remove the template and cut a 6 $\frac{1}{4}$ " diameter hole centered on this mark.

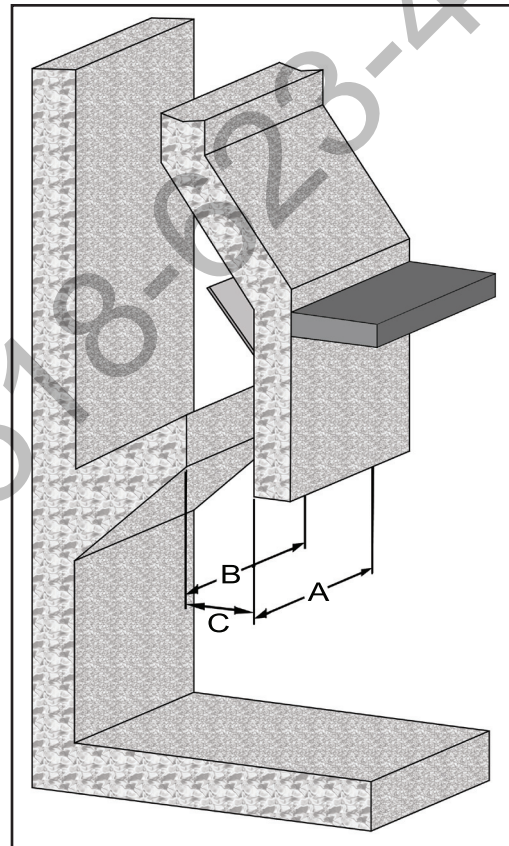

Figure 18: 3D of Dimensions needed from the Fireplace.

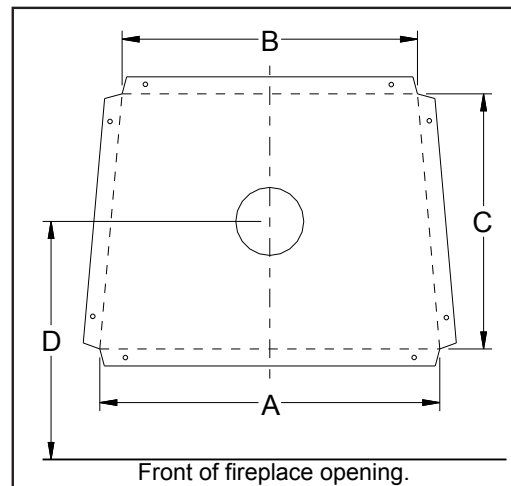
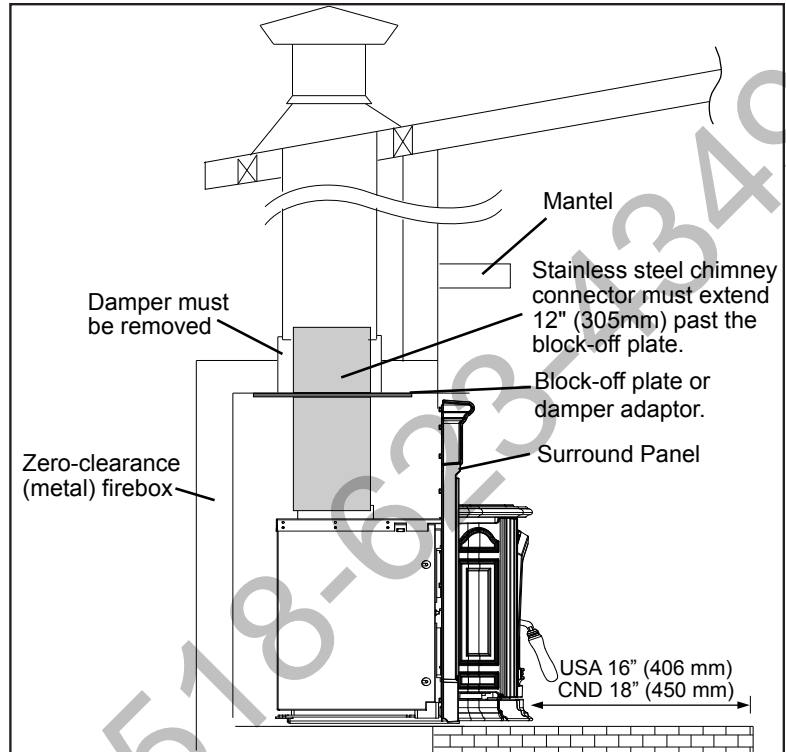

Figure 19: Layout of the Block-Off Plate.

# INSTALLATION

4. Using the template make the block-off plate of 24 gauge or thicker steel. Drill two (2) holes in each flange for mounting the plate.
5. Mount the block-off plate using masonry screws in a masonry fireplace and sheet metal screws on a zero-clearance fireplace (screws need only be long enough to penetrate the first layer of metal).
6. Insulate the block-off plate using high - temperature fiberglass insulation and furnace cement.
7. After installing the unit into place and the pipe through the block-off plate, use high - temperature fiberglass insulation and furnace cement to seal any gaps between the pipe and block-off plate (allow the cement to dry for at least 24 hours before burning).



**Figure 20: Insert Install into a Zero-Clearance Fireplace.**

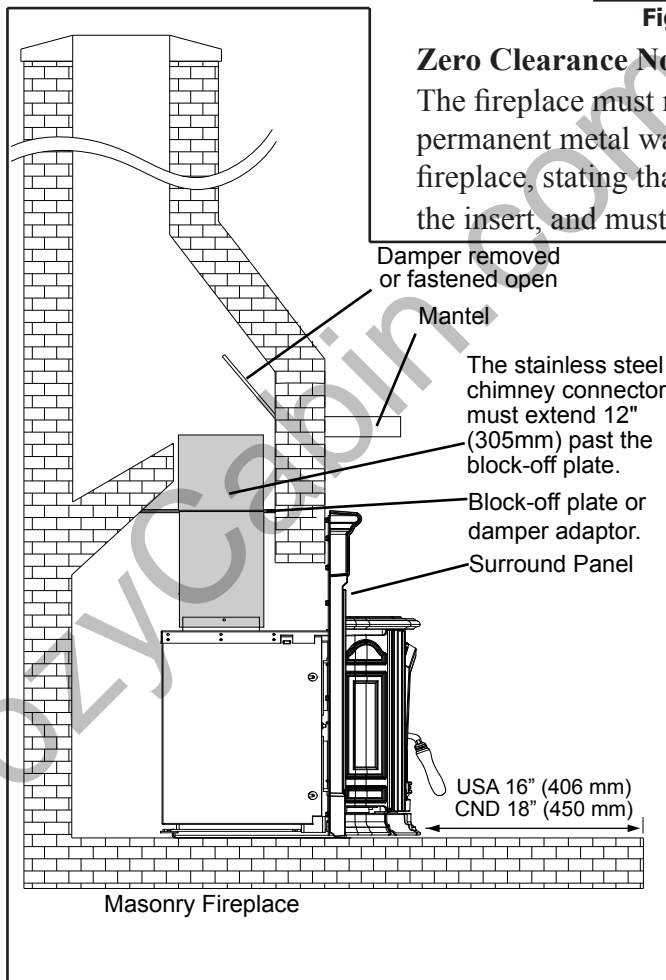

**Fig. 21: Masonry Fireplace Direct Connection Insert**

## Zero Clearance Notes:

The fireplace must not be altered, except for the exceptions below. The permanent metal warning label provided must be attached to the back of the fireplace, stating that the fireplace may have been altered to accommodate the insert, and must be returned to original condition for use as a conventional fireplace. The following modification of factory built fireplaces are permissible: removal of damper, removal of smoke shelf or baffle, removal of ember catches, removal of fire grate, removal of viewing screen/curtain, and removal of doors. The factory built chimney must be listed per UL 127 (US), and meet type HT requirements of UL 103 (US). Factory built fireplace chimneys tested to UL 127-1998, may be at the fireplace manufacturer's option, tested to the same criteria as UL 103 HT requirements. If the chimney is not listed as meeting HT requirements, or if the factory built fireplace was tested prior to 1998, a full height listed chimney liner must be installed from the appliance flue collar to the chimney top. The liner must meet type HT requirements (2100°F) per UL 1777 (US). The liner must be securely attached to the insert flue collar and the chimney top. To prevent room air passage to the chimney cavity of the fireplace, seal either the damper area around the chimney liner with high temperature sealant or the fireplace front with fiberglass batting.

# INSTALLATION

## MODEL 1200-C BRICK PLACEMENT & TUBE LOCATIONS:

COMPLETE THE STOVE AND SMOKE PIPE INSTALLATION BEFORE PLACING THESE BRICKS.

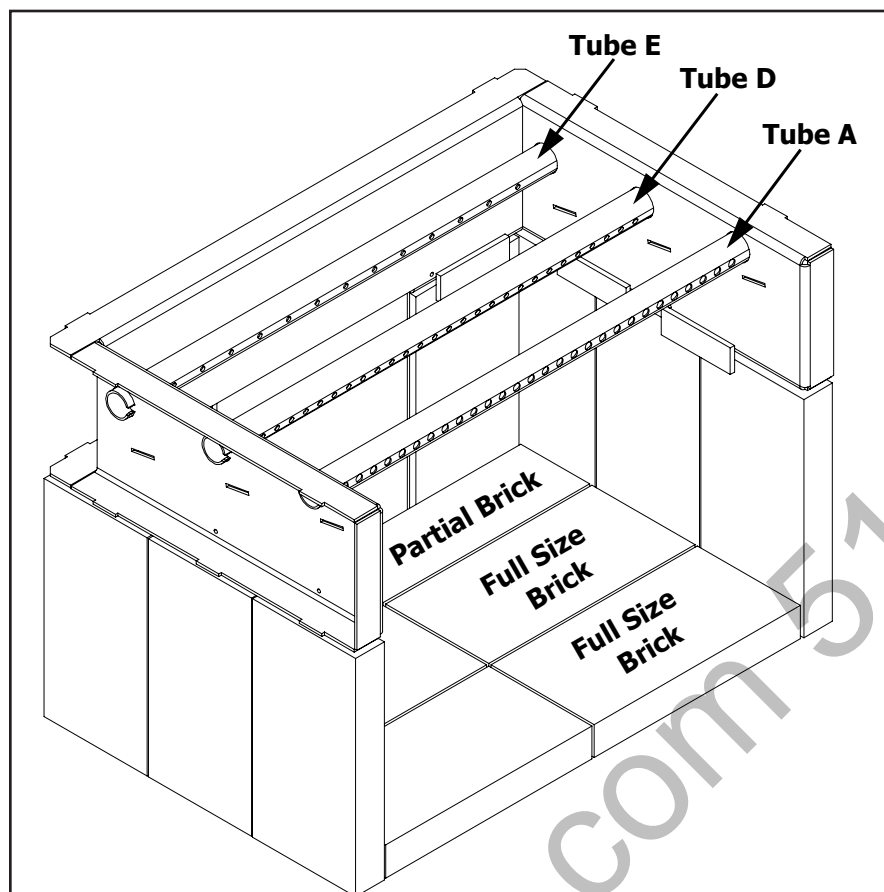

Figure 22: Brick Placement for 1200-C shown with Secondary Air Channel and Tubes.

### TOTAL BRICKS:

- 12 - Full size bricks 9" long x 4.5" wide x 1.25" thick  
(22.9 cm long x 11.4 cm wide x 3.2 cm thick)
- 2 - Partial bricks 9" long x 3" wide x 1.25" thick  
(22.9 cm long x 7.6 cm wide x 3.2 cm thick)

**Removing Air Tube:** If a secondary air tube needs to be removed, place a screwdriver (any style except flat head) into one of the air holes and tap it with a hammer/mallet to the left until the right end of the tube is freed. To install a secondary air tube reverse the above instructions.

**IMPORTANT:** All secondary air tubes must be in place for proper operation.

1. Place the three (3) full size bricks along each side of the firebox and one (1) full size brick on either side of the back of the firebox.
2. To place the floor bricks, lay the two (2) partial bricks along the back of the floor. Then lay four (4) full size bricks in the front. The spaces between the bricks will soon fill with ashes.

**When replacing bricks, use only pumas type fire bricks.**

# INSTALLATION

## MODEL 1700-C BRICK PLACEMENT & TUBE LOCATIONS:

COMPLETE THE STOVE AND SMOKE PIPE INSTALLATION BEFORE PLACING THESE BRICKS.

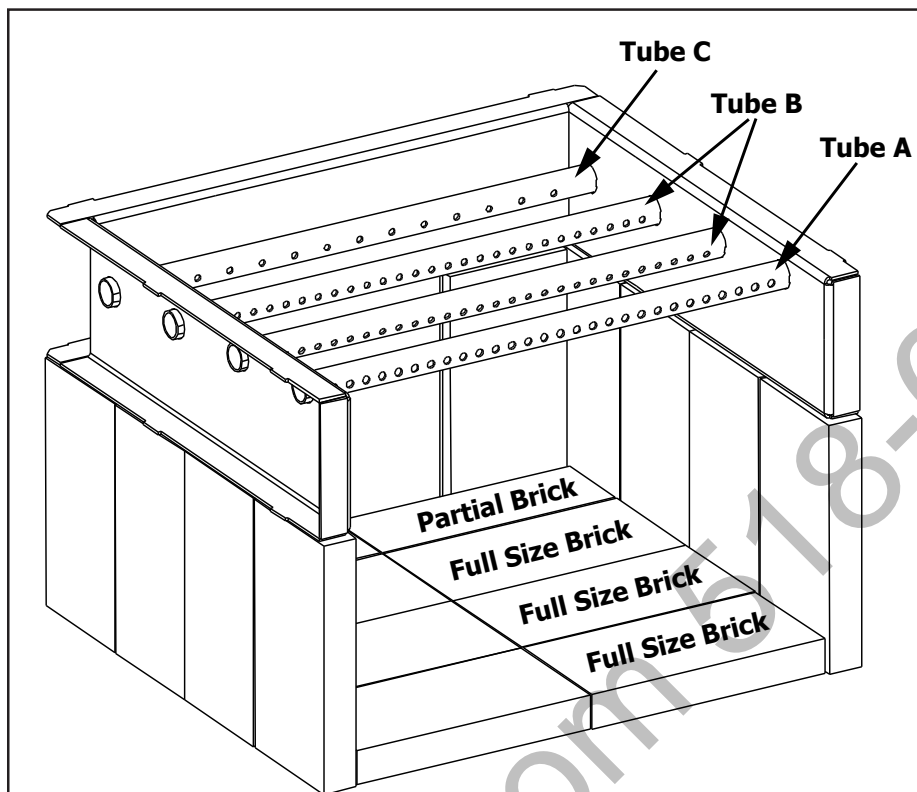

Figure 23: Brick Placement for 1700-C shown with Secondary Air Channel and Tubes.

1. Place the four (4) full size bricks along each side of the firebox and one (1) full size brick on either side of the back of the firebox.
2. To place the floor bricks, lay the two (2) partial bricks along the back of the floor. Then lay six (6) full size bricks in the front. The spaces between the bricks will soon fill with ashes.

**When replacing bricks, use only pumas type fire bricks.**

### **TOTAL BRICKS:**

- 16 - Full size bricks 9" long x 4.5" wide x 1.25" thick  
(22.9 cm long x 11.4 cm wide x 3.2 cm thick)
- 2 - Partial bricks 9" long x 3" wide x 1.25" thick  
(22.9 cm long x 7.6 cm wide x 3.2 cm thick)

**Removing Air Tube:** If a secondary air tube needs to be removed, place a screwdriver (any style except flat head) into one of the air holes and tap it with a hammer/mallet to the left until the right end of the tube is freed. To install a secondary air tube reverse the above instructions.

**IMPORTANT:** All secondary air tubes must be in place for proper operation.

# INSTALLATION

## C-CAST CERAMIC BAFFLE INSTALLATION:

1. Slide the right C-Cast Ceramic Baffle in over the secondary air tubes at the top of the firebox. The tab must be on the top and pointing towards the center and the smooth side is to face down.
2. Hook the outside edge of the baffle over the top of the secondary air chamber. This will make room to for the installation of the left C-Cast Ceramic Baffle.
3. Slide the left C-Cast Ceramic Baffle in over the secondary air tubes. The tab must be on the bottom and pointing towards the center and the smooth side is to face down.
4. Pull the baffles together in the middle so the right tab rests on top of the left tab. Ensure the baffles are flush with the back and both sides of the firebox.

**Note:** If the bolts on the flue collar are not to the left and right of the hole, the front secondary air tube will need to be removed in order to install or remove the C-Cast Ceramic Baffles. To remove the front secondary air tube place a screwdriver (any style except flat head) into one of the air holes and tapping it with a hammer/mallet to the left.

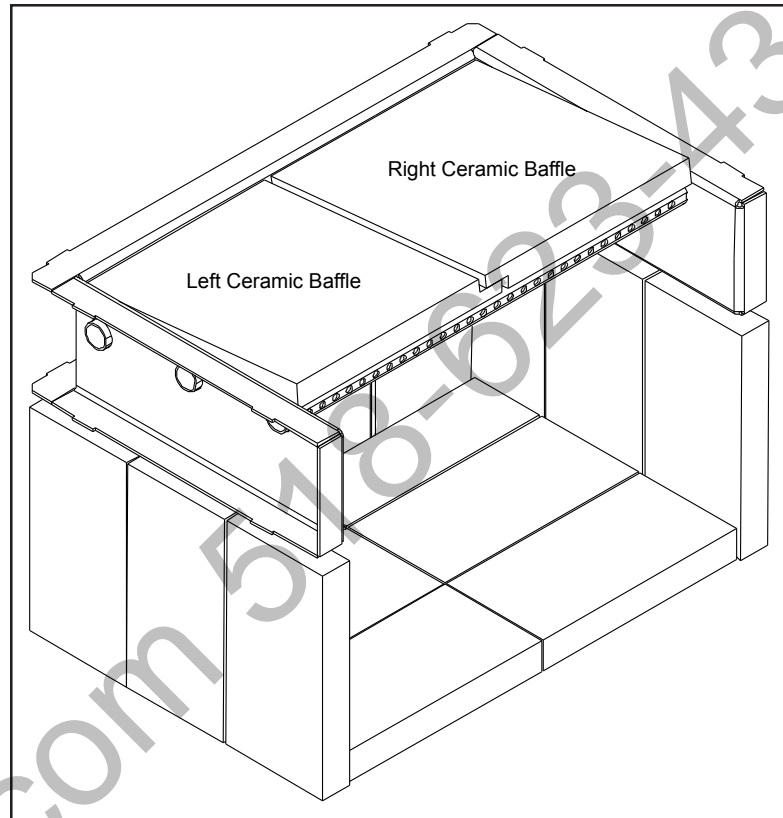

Figure 24: Installation of C-Cast Ceramic Baffle.

# INSTALLATION

## FAN WIRING DIAGRAMS:

This appliance, when installed, must be electrically connected and grounded in accordance with local codes or in the absence of local codes, with the current CSA C22.1 CANADIAN ELECTRICAL CODE, Part 1, SAFETY STANDARDS FOR ELECTRICAL INSTALLATIONS, or THE NATIONAL ELECTRICAL CODE ANSI / NFPA 70 in the USA.

**CAUTION** Label all wires prior to disconnection when servicing controls. Wiring errors can cause improper and dangerous operation. Verify proper operation after servicing.

**DO NOT** oil the fan bearings.

**DO NOT** cut or remove the grounding prong from the plug.

**DO NOT** route the power cord beneath the heater.

**WARNING:** This appliance is equipped with a three-prong (grounding) plug for your protection against shock hazard and should be plugged into a properly grounded three-prong receptacle.

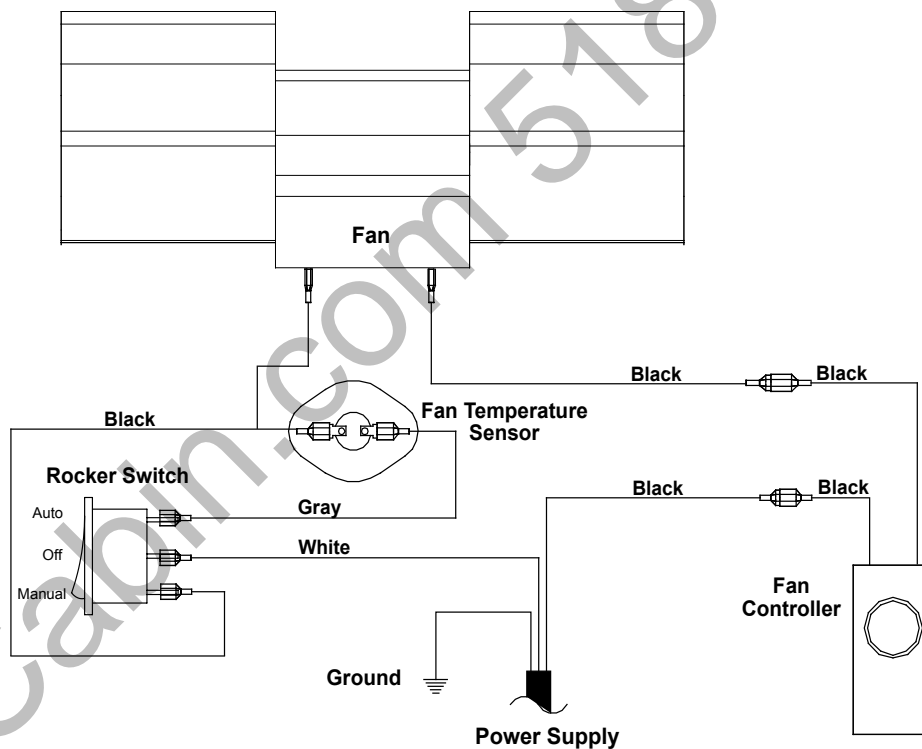

Figure 25: Fireplace Insert Fan Kit Wiring Diagram.

## DISASSEMBLY

**CAUTION: ENSURE POWER CORD IS UNPLUGGED AND UNIT IS COLD BEFORE ATTEMPTING ANY DISASSEMBLY.**

### REMOVAL OF CAST TOP

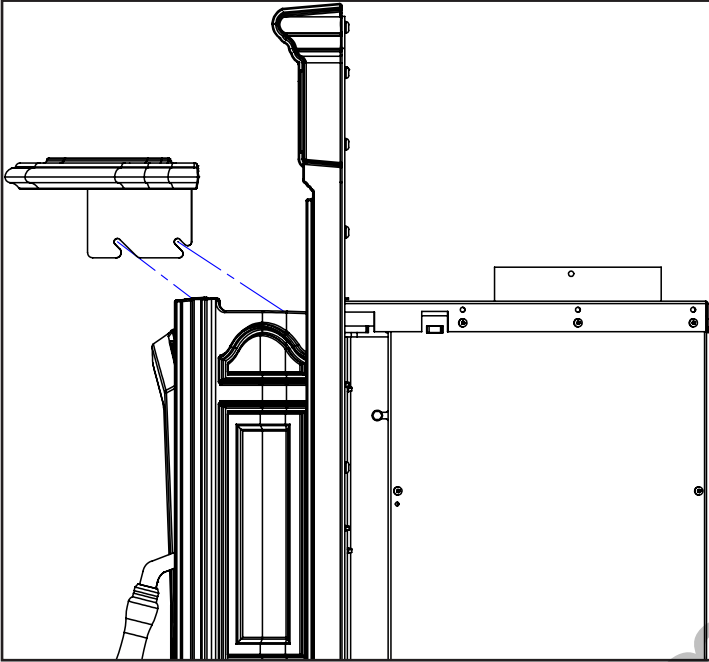

Figure 26: Removal of Cast Top

1. Open the door and loosen the 1/4" screws using a 3/8" wrench.
2. Remove the cast top from the unit by lifting up and forward. (For re-assembly, ensure that slots in the brackets are fully seated on the bolts)

### REMOVAL OF DOOR

1. Fully open the door.
2. With the help of another person, lift the door straight up off the hinge pins.

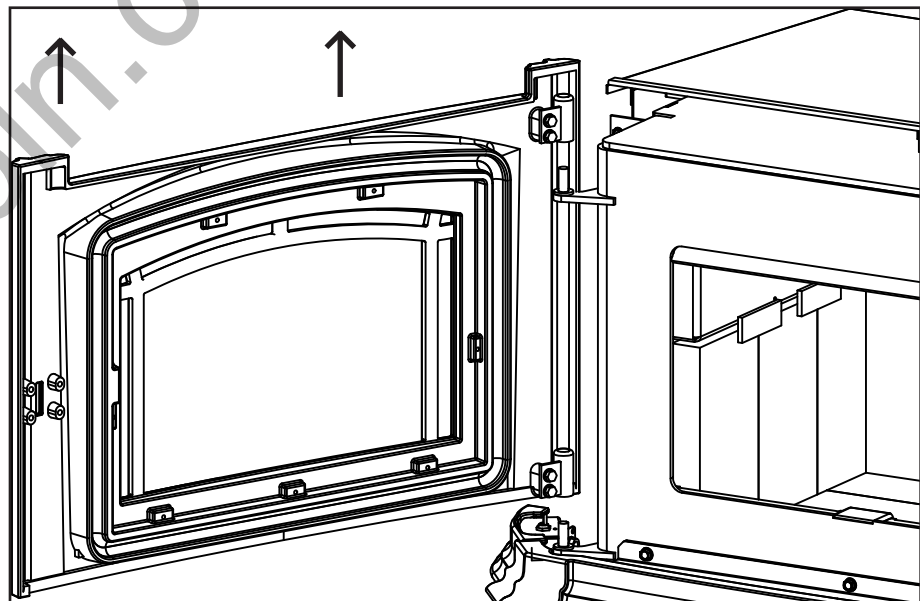

Figure 27: Removal of Door

# DISASSEMBLY

## REMOVAL OF THE CAST SIDE PANELS:

1. Loosen (but do not remove) the three 1/4" screws on the side casting using a 3/8" wrench.
2. Lift the side casting up and out.  
(Repeat steps 1 and 2 for other side)

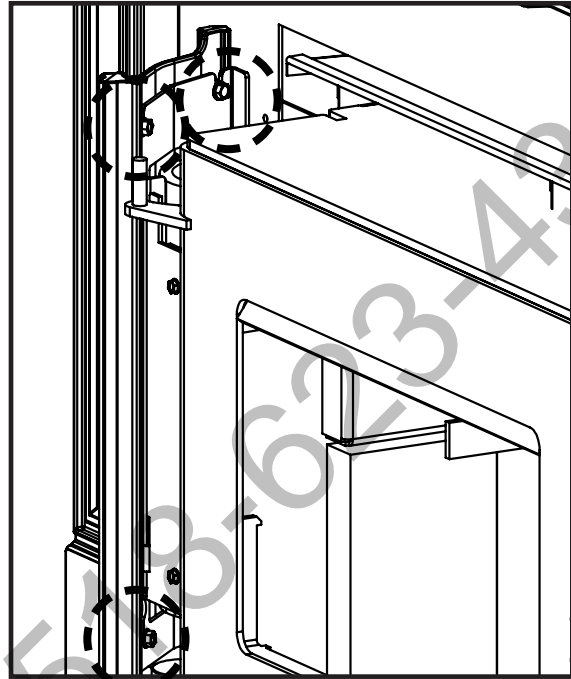

Figure 28: Cast Side Panel Screws

## REMOVAL OF SIDE BRACKETS

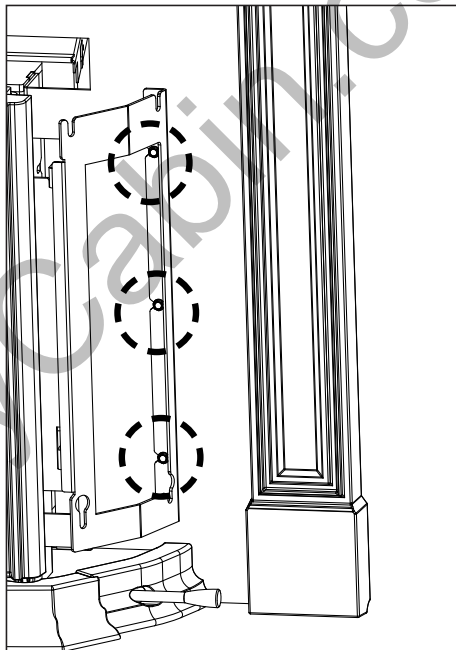
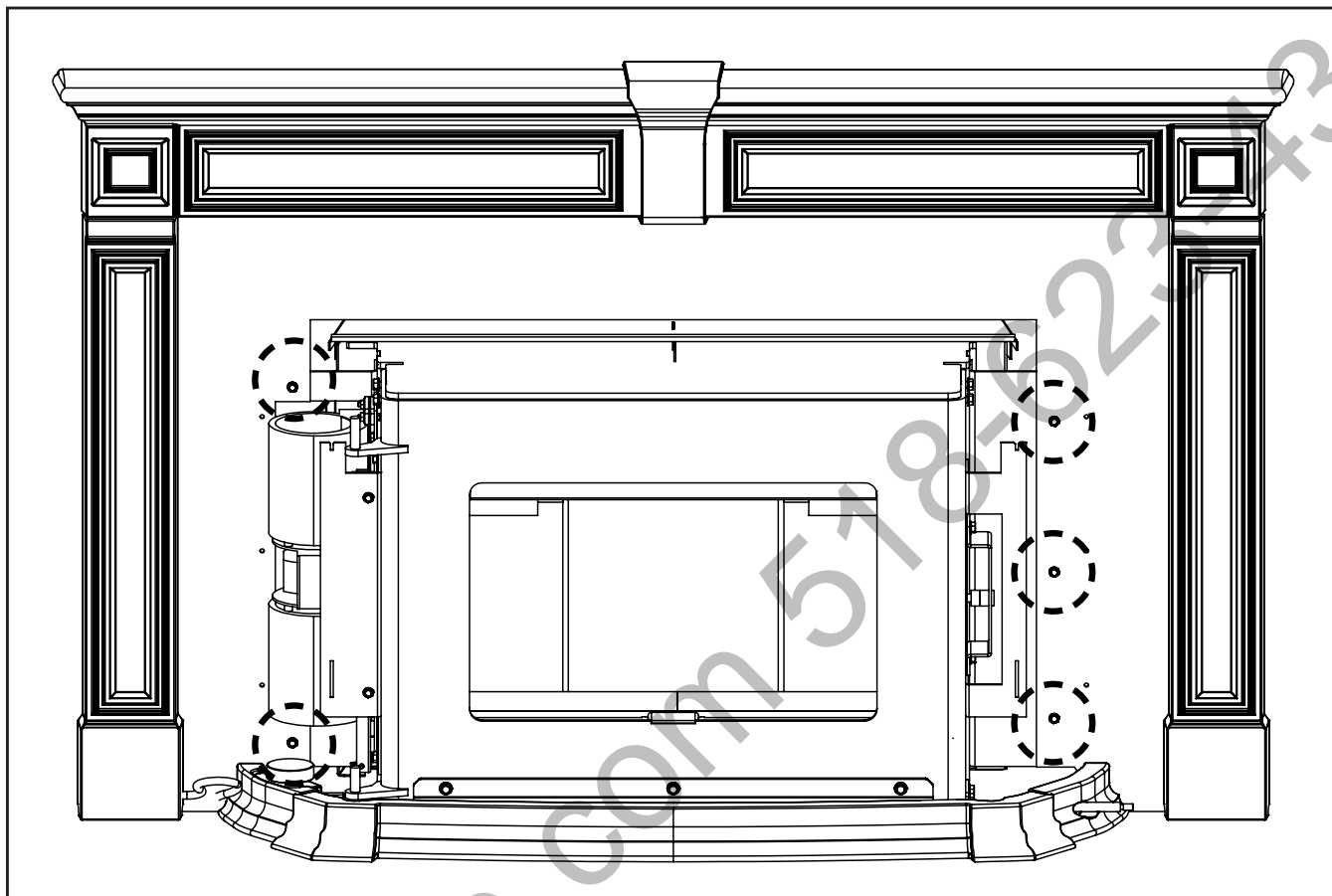

Figure 29: Cast Side Bracket Bolts

1. Use a 5/16" socket to remove the three screws holding the bracket to the surround panel
2. Lift the bracket up and out to remove it.  
(Repeat steps 1 and 2 for other side)

# DISASSEMBLY

## REMOVAL OF SURROUND PANEL



**Figure 30: Removal of Surround Panel**

1. Remove the fan control dial by gently pulling straight up.
2. Remove the two screws on the left side with a 5/16" socket and then do the same for the three screws on the right. Be sure to support the panel before removing the last screws.
3. With the help of another person, carefully lift the surround panel up.

# DISASSEMBLY

## REMOVAL OF LOWER FRONT CASTING

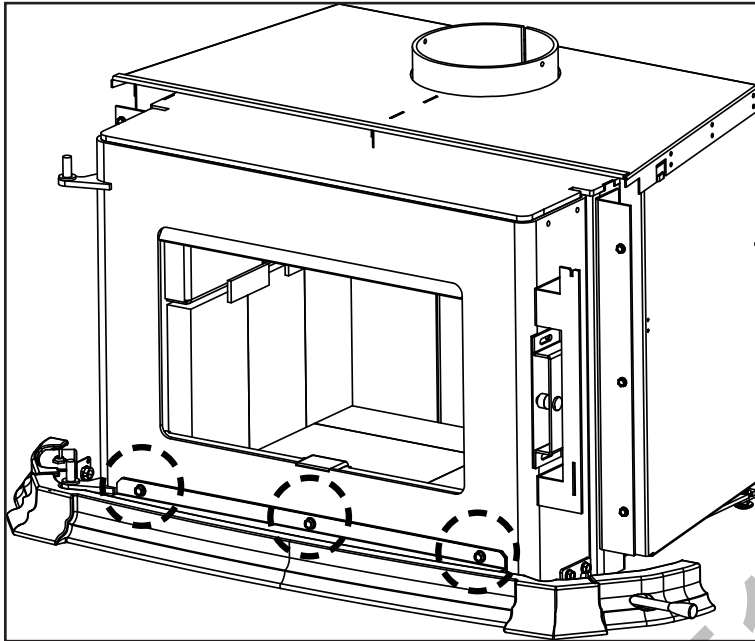

Figure 31: Lower Front Casting Removal

1. Use a 3/8" socket to remove the three 1/4" bolts.

## REMOVAL OF LOWER SIDE CAST:

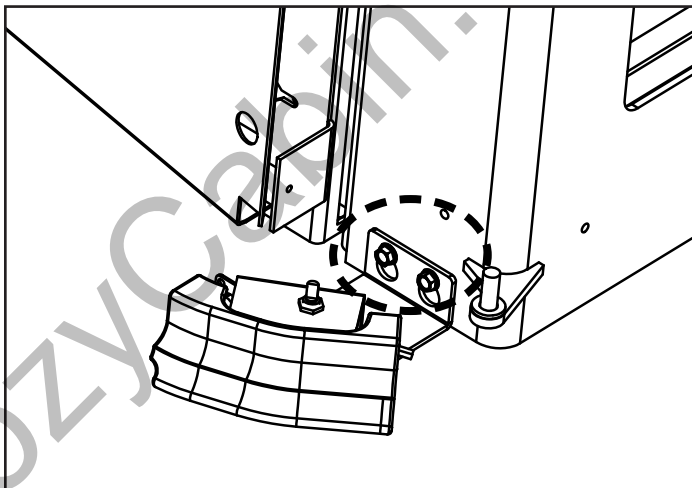

Figure 32: Lower Side Cast Removal

1. Use a 3/8" wrench to loosen the two 1/4" bolts.
2. The cast trim bracket can now be lifted off the keyslots. (Power cord not shown)
3. Repeat for the other side.

Note: the slider knob must be unscrewed from the slider rod for the other side.

# DISASSEMBLY

## REMOVAL OF FAN ASSEMBLY

1. Follow the disassembly steps from Figures 25-28 (Left side only).
2. Pull off the fan control dial by lifting up.
3. Unplug the wire connections. A light wiggle will help loosen the connectors.
4. Use a 3/8" socket to remove the two 1/4" bolts. The entire fan assembly can now be removed.

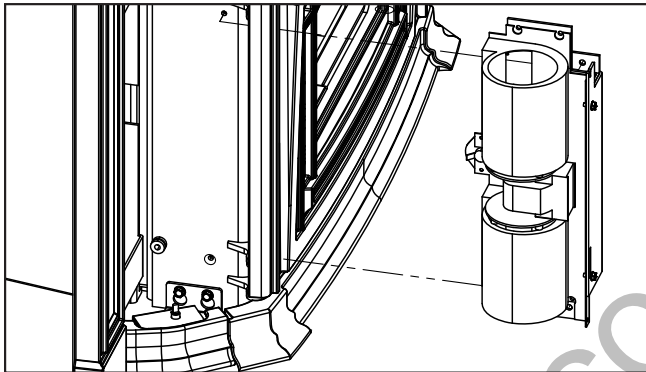

Figure 34: Fan Assembly Removed

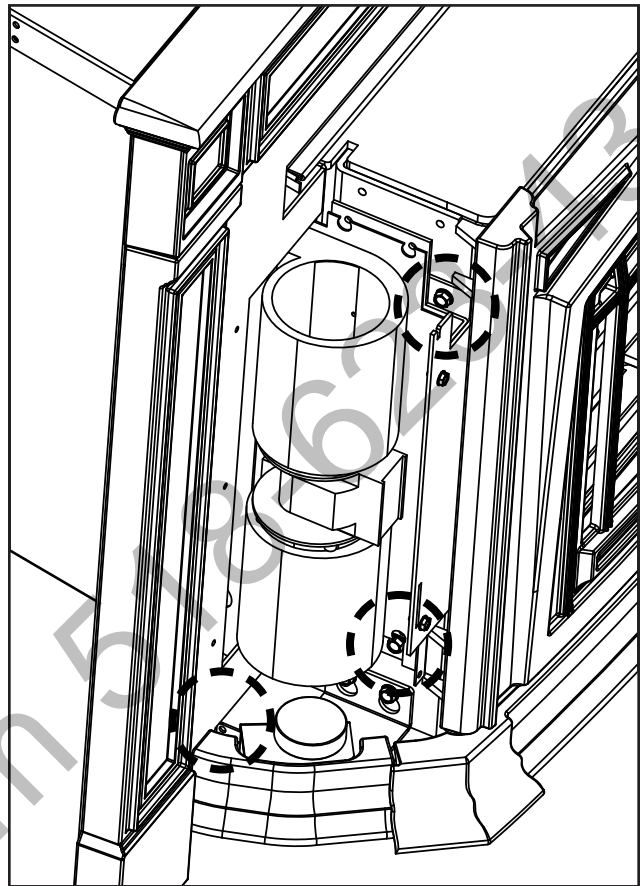

Figure 33: Fan Removal

## DOOR LATCH ADJUSTMENT:

Over time as the door gasket fully compresses to the face of the firebox, it may be necessary to adjust the door latch position to maintain a tight seal. Signs that the door latch may need adjusting are if the door handle feels overly loose when closed, or if you notice air leaks occurring during low burns.

1. Follow the disassembly steps from Figures 26-29 (Right side only).
2. Use a 3/8" socket to loosen the two 1/4" bolts and slide the latch slightly back. Retighten the bolts and latch the handle. The handle should provide a bit of resistance and close firmly.

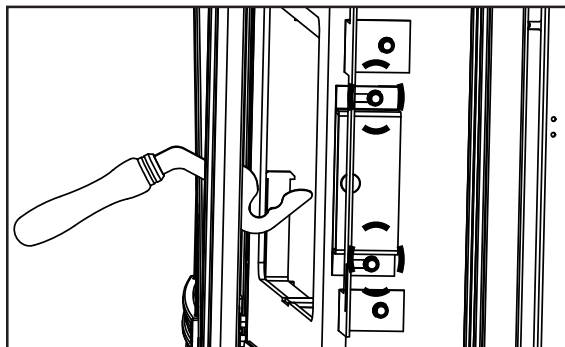

Figure 35: Latch Adjustment

# RATING LABEL

**Tested & Listed By**  
  
**OMNI-Test Laboratories, Inc.**  
Certified for use in Canada & USA / Certifié pour installation au Canada et aux États-Unis.

**DO NOT REMOVE THIS LABEL / NE PAS ENLEVER CETTE ÉTIQUETTE**  
**LISTED SOLID FUEL SPACE HEATER / IDENTIFIÉ COMME UN FOYER À COMBUSTIBLE SOLIDE**

Boston 1200 FS 268-S-04b-2   
  Kodiak 1200 FS 268-S-04b-2   
  Boston 1200 FPI 268-S-06c-2   
  Venice 1200 FPI 268-S-05-2   
  1200 KI FPI 268-S-05-2  
 Boston 1700 FS 268-S-01b-2   
  Kodiak 1700 FS 268-S-01b-2   
  Boston 1700 FPI 268-S-06c-2   
  Venice 1700 FPI 268-S-06c-2   
  1700 KI FPI 268-S-06c-2

**Serial No. / No. De Série:**

Models 1200 and 1700 Freestanding units: Room Heater, Solid Fuel Type. Also For Use in Mobile Homes. Tested to ULC-S627-00, ULC-S628-93 (FPI only), & UL-1482-11.

Modèles 1200 et 1700 items indépendants: Chauffage pièce, le type de combustible solide, également pour une utilisation dans les maisons mobiles. Testé selon ULC-S627-00, ULC-S628-93 (FPI seulement), & UL-1482-11.

Install and use only in accordance with the manufacturers installation and operating instructions. Contact local building or fire officials about restrictions and installation inspection in your area. Use 6" (150 mm) diameter minimum 24 MSG black or 25 MSG blue steel connector listed factory-built chimney suitable for use with solid fuels or masonry chimney. See local building code and manufacturer's instructions for precautions required for passing a chimney through a combustible wall or ceiling. Do not pass chimney connector through a combustible wall or ceiling. Minimum clearances from horizontal connector and ceiling 18" (455 mm). Do not connect this unit to a chimney flue servicing another appliance.

Le dispositif doit être installé et opéré conformément aux instructions d'installation et d'opération du fabricant contactez le service local de l'inspection des bâtiments ou l'officier pompier concernant les restrictions et l'inspection d'installation dans votre localité. Utilisez des connecteurs répertoriés 24 MSG noir ou 25 MSG en acier bronzée de 6" (150 mm) minimum, et une cheminée de fabrication industrielle, appropriée pour utilisation avec des combustibles solides ou avec une cheminée de maçonnerie. Vérifiez les précautions à prendre exigées par le code local et les instructions du fabricant concernant les conditions pour passer la cheminée à travers un mur ou un plafond combustible. Ne pas installer le connecteur de la cheminée à travers un mur ou un plafond combustible. Espaces libres minimum d'un connecteur horizontal et plafond sont 18" (455 mm) ne pas connecter ce dispositif à un conduit de cheminée qui sert déjà un autre dispositif.

Model / Modèle	Single wall pipe / Seul connecteur de mur		**Double wall pipe / Double connecteur de mur		Double wall pipe with efficiency shield (Flat top model only) / Double connecteur de mur avec la protection d'efficacité (Le modèle plat seulement)		Top vent out back wall with min. 24" (610mm) vertical rise, double wall pipe / Double vent hors de la paroi arrière avec le min. 24" (610 mm) l'ascension verticale; double connecteur de mur	
	1200	1700	1200	1700	1200	1700	1200	1700
A Sidewall to unit / De la paroi latérale au dispositif	13" (330 mm)	20" (508 mm)	13" (330 mm)	13" (330 mm)	13" (330 mm)	13" (330 mm)	14" (356 mm)	11" (279 mm)
B Backwall to unit / De la paroi arrière au dispositif	11" (279 mm)	12" (305 mm)	10" (254 mm)	10" (254 mm)	8" (203 mm)	7" (178 mm)	12" (305 mm)	13" (330 mm)
C Adjacent wall to corner of unit / De la paroi adjacente au coin de dispositif	9" (229 mm)	10" (254 mm)	8" (203 mm)	8 1/2" (216 mm)	6 1/2" (165 mm)	6" (152 mm)		
D Sidewall to connector / De la paroi latérale au connecteur	22" (559 mm)	29" (737 mm)	22" (559 mm)	22" (559 mm)	22" (559 mm)	22" (559 mm)	23" (584 mm)	16" (381 mm)
E Backwall to connector / De la paroi arrière au connecteur	14" (356 mm)	15" (381 mm)	13" (330 mm)	13" (330 mm)	11" (279 mm)	10" (254 mm)	15" (381 mm)	15" (406 mm)
F Adjacent wall to connector / De la paroi adjacente au connecteur	17 1/2" (445 mm)	18 1/2" (470 mm)	16 1/2" (419 mm)	17" (432 mm)	15" (381 mm)	14 1/2" (368 mm)		
G † Front of door opening to edge of hearth / Le devant d'ouverture de porte au bord de coussin de cœur					USA 16" (406 mm)	CND 18" (450 mm)		
H † Side/back of unit to edge of hearth / Le latérale/arrière de dispositif au bord de coussin de cœur					USA 6" (152 mm)	CND 8" (200 mm)		

**CAUTION:** An uninsulated smoke pipe must not pass through an attic, roof space, closet or similar concealed space, or through a floor, ceiling, wall, or partition, or any combustible construction.  
 † FLOOR PROTECTION: If a stove is installed on a combustible floor, it must have the legs or pedestal attached and be on a NON COMBUSTIBLE hearth pad.  
 \* ALL CLEARANCES CAN BE REDUCED WITH SHIELDING ACCEPTABLE TO THE LOCAL AUTHORITY. SINGLE WALL:  
 IN CANADA: Any ULC-S629 listed chimney system with the accompanying listed single wall vent connector.  
 IN U.S.A.: Any UL 103 HT listed chimney system with the accompanying listed single wall vent connector.  
 \*\*DOUBLE WALL:  
 IN CANADA: Any ULC-S629 listed chimney system with the accompanying listed double wall vent connector.  
 IN U.S.A.: Any UL 103 HT listed chimney system with the accompanying listed double wall vent connector.  
 DOUBLEWALL IS REQUIRED FOR MOBILE HOME INSTALLATIONS.

**MISE EN GARDE:** Un insulated tuyau de fumée ne doit pas passer par un grenier, un espace de toit, le placard ou l'espace dissimulé similaire, ou par un plancher, un plafond, un mur, ou une cloison, ou une construction combustible.  
 † PROTÉGER LE PLANCHER: Si une cuisinière est installée sur un sol combustible, il doit avoir un piédestal attaché et être sur un coussin non-combustible.  
 TOUS ESPACES LIBRES AUX MATÉRIELS COMBUSTIBLES PEUVENT ÊTRE RÉDUITS AVEC PROTEGEANT ACCEPTABLE À L'AUTORITÉ LOCALE.  
 Seul Connecteur de Mur:  
 Au Canada: Certifiée, seul connecteur de mur avec toute systèmes de cheminée listée sous ULC-S629.  
 Aux États-Unis: Certifiée seul connecteur de mur avec toute systèmes de cheminée listée sous UL 103 HT.  
 \*\*Double Connecteur de Mur:  
 Au Canada: Certifiée double connecteur de mur avec toute systèmes de cheminée listée sous ULC-S629.  
 Aux États-Unis: Certifiée double connecteur de mur avec toute systèmes de cheminée listée sous UL 103 HT.

**Alcove (Use double wall pipe) / Alcôve (Utilisant le double connecteur de mur)	Model/Modèle 1200	Model/Modèle 1700
I Total width / Largeur totale	55" (1397 mm)	51" (1295 mm)
J Total height / Hauteur totale	78" (1981 mm)	72" (1829 mm)
K Top of stove to ceiling / Le sommet de poêle au plafond	49" (1245 mm)	44" (1118 mm)
L Sidewall to unit / De la paroi latérale au dispositif	15" (381 mm)	13" (330 mm)
M Sidewall to connector / De la paroi latérale au connecteur	24" (610 mm)	22" (559 mm)
N Backwall to unit / De la paroi arrière au dispositif	12" (305 mm)	8" (203 mm)
O Backwall to connector / De la paroi arrière au connecteur	15" (381 mm)	11" (279 mm)
P Maximum Depth / Profondeur maximum	48" (1220 mm)	48" (1220 mm)

Models 1200 and 1700 inserts may be installed as an insert in a masonry fireplace. / On peut encastrier les modèles 1200 et 1700 dans un foyer de maçonnerie.

Model / Modèle	1200 FPI	1700 FPI
A To unshielded side wall / aux mur non protégé	10" (254 mm)	10" (254 mm)
B To an unshielded 6" (203 mm) mantle / aux manteau 6" non protégé	21" (533 mm)	24" (610 mm)
C To top facing (protruding 1/2" [19 mm] clearance / aux revêtement supérieur	17 1/2" (445 mm)	19 1/2" (495 mm)
D To side facing (protruding 1/2" [19 mm] clearance / aux revêtement à côté	11" (279 mm)	11" (279 mm)
E † From door opening of unit to edge of floor protection / De ouverture de la porte de l'unité à bord de la protection de plancher	USA 16" (406mm) / CND 18" (450mm)	
F † From side of unit to edge of floor protection / Du côté de l'unité au bord de la protection de plancher	USA 6" (152 mm) / CND 8" (200 mm)	

**OPERATE ONLY WITH DOORS CLOSED.** Only open door to feed fire. For use with solid wood fuels only. Do not use any other type of fuel. Do not use grate or elevate fire build wood fire directly on hearth. Do not overfire. Do not obstruct beneath the heater. If heater or chimney connector glows, you are overfiring. Inspect and clean chimney frequently under certain conditions of use, creosote buildup may occur rapidly. The provided insulation materials are required for operation. Keep furnishing and other combustibles well away from heater. Replace glass only with 5 mm thick ceramic glass. Optional component for FS: fan, electrical rating 115V, 60 Hz 1 Amp (Part # EFW-261). Combustion air openings are not to be obstructed.  
**Danger:** Risk of electrical shock. Disconnect power before servicing unit. Route cord away from heater.

**CAUTION:** HOT WHILE IN OPERATION. DO NOT TOUCH. KEEP CHILDREN, CLOTHING AND FURNITURE AWAY. CONTACT MAY CAUSE SKIN BURN. READ NAMEPLATE AND INSTRUCTIONS.

MADE IN CANADA / FABRIQUÉ AU CANADA      MANUFACTURED BY / FABRIQUÉ PAR: SHERWOOD INDUSTRIES LTD. 6782 OLDFIELD ROAD, SAANICHTON, BC CANADA

**DATE OF MANUFACTURE / DATE DE FABRICATION:**

J	F	M	A	M	J	J	A	S	O	N	D		
									2015	2016	2017	2018	2019

C-14615

Figure 36: Rating Label Sample

## PARTS LIST

Reference #	Description	Part #
1	120F (49C) Ceramic Fan Temperature Sensor	EC-001
2	FPI Fan Controller 115V	EC-039
3	Domestic Power Cord 115V	EC-042
4	Heyco Strain Relief	EC-044
5	Wood Door Gasket	EF-168
6	Glass with Tape	10-000
7	1200 & 1700 Front Secondary Air Tube A	50-1099
8	1700 Rear Secondary Air Tube C	50-1100
9	1700 Middle Secondary Air Tube B	50-1101
10	1200 Secondary Air Tube Rear E	50-1102
11	1200 Secondary Air Tube Middle D	50-1103
12	Pumice Brick 3" x 9"	50-1104
13	Pumice Brick 4.5" x 9"	50-1105
14	Glass Retainer Kit (With Screws)	50-2389
15	1200 & 1700 Left Shield Assembly	50-1144
16	1200 & 1700 Right Shield Assembly	50-1145
17	1200 C-Cast Ceramic Baffle (1 Piece)	50-1146
18	1700 C-Cast Ceramic Baffle (1 Piece)	50-1147
19	1200 & 1700 Insert Flue Collar Assembly	50-1148
20	1200 & 1700 Ceramic Flue Gasket	50-1413
21	Kodiak/Venice FPI Angled Flue Collar	50-1565
22	1200/1700 Replacement Fan w/Mount	50-2390
23	Boston Steel Surround Panel	50-2415
24	Boston Cast Top	50-2394
25	Boston Door Assembly (No Handle)	50-2392
26	Boston Door Handle Complete	50-2393
27	Cast Base Left	50-2398
28	Cast Base Right	50-2399
29	Cast Base Center	50-2397
30	Cast Side Left	50-2395
31	Cast Side Right	50-2396
32	Cast Surround Top Right	50-2403
33	Cast Surround Side	50-2400
34	Cast Surround Keystone	50-2401
35	Cast Surround Top Left	50-2402
	Boston FPI Owner's Manual	50-2362

# PARTS DIAGRAM

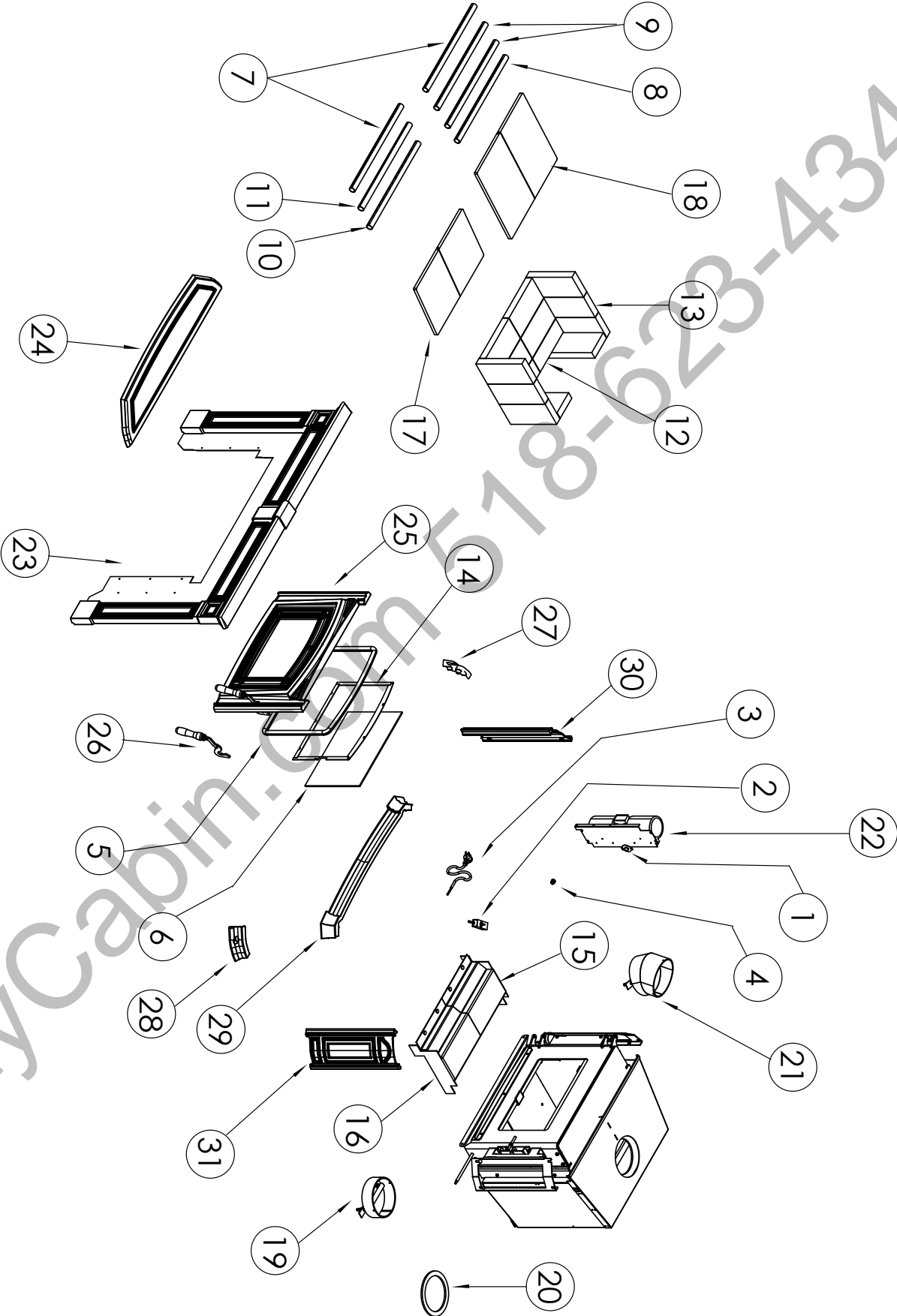

CozyCabin.com 18-628-4349

## NOTES

---

CozyCabin.com 518-623-4349



# Warranty for Enviro Wood Products

Sherwood Industries Ltd. ("Sherwood") hereby warrants, subject to the terms and conditions herein set forth, this product against defects in material and workmanship during the specified warranty period starting from the date of original purchase at retail. In the event of a defect of material or workmanship during the specified warranty period, Sherwood reserves the right to make repairs or to assess the replacement of a defective product at Sherwood's factory. The shipping costs are to be paid by the consumer. All warranties by Sherwood are set forth herein and no claim shall be made against Sherwood on any oral warranty or representation.

## Conditions

- A completed warranty registration must be submitted to Sherwood within 90 days of original purchase via the online warranty registration page or via the mail-in warranty registration card provided. Have the installer fill in the installation data sheet in the back of the manual for warranty and future reference.
- This warranty applies only to the original owner in the original location from date of install.
- The unit must have been properly installed by a qualified technician or installer, and must meet all local and national building code requirements.
- The warranty does not cover removal and re-installation costs.
- Sherwood Industries Ltd. reserves the right to make changes without notice.
- Sherwood Industries Ltd. and its employees or representatives will not assume any damages, either directly or indirectly caused by improper usage, operation, installation, servicing or maintenance of this appliance.
- A proof of original purchase must be provided by you or the dealer including serial number.

## Exclusions

An expanded list of exclusions is available at [www.enviro.com/help/warranty.html](http://www.enviro.com/help/warranty.html)

This warranty does not cover:

- Damage as a result of improper usage or abuse.
- Damage caused from over-firing due to incorrect setup or tampering.
- Damage caused by incorrect installation.

## To the Dealer

- Provide name, address and telephone number of purchaser and date of purchase.
- Provide date of purchase. Name of installer and dealer. Serial number of the appliance. Nature of complaint, defects or malfunction; description and part # of any parts replaced.
- Pictures or return of damaged or defective product may be required.

## To the Distributor

- Sign and verify that work and information are correct.

## Sherwood Industries Ltd.

6782 Oldfield Road, Victoria, BC . Canada V8M 2A3  
 Online warranty registration: [www.enviro.com/warranty/](http://www.enviro.com/warranty/)

Category	One Year	Two Year	Limited Lifetime (7yr)
Parts <sup>1</sup> (unit serial number required)		✓	
Firebox (excluding bricks) <sup>2</sup>			✓
Ceramic Baffle <sup>3</sup>			✓
Secondary Air Tubes			✓
Surround Panels (excluding finish)			✓
Pedestals / Legs (excluding finish)			✓
Ceramic Glass <sup>4</sup>	✓		
Door Assembly (excluding gasket)			✓
Slider Control			✓
Shield Assembly			✓
Electrical Components		✓	
Convection Fan		✓	
Exterior Surface Finishing <sup>5</sup>	✓		
Gasket	✓		
Labour		✓	

<sup>1</sup> Whereas warranty has expired, replacement parts will be warranted for 90 days from part purchase date. Labour not included.

Unit serial number required.

<sup>2</sup> Warranty does not cover damage caused from burning artificial/firestarter log varieties.

<sup>3</sup> Excludes damage caused by loading wood, cleaning or service.

<sup>4</sup> Glass is covered for thermal breakage. Photos of box, inside of door, and unit serial # must be supplied for breakage due to shipping.

<sup>5</sup> Exterior Surface finishing covers Plating, Enamel or Paint and excludes colour changes, chipping, and fingerprints.

Travel costs not included.

No warranty on replacement firebricks

# INSTALLATION DATA SHEET

The following information must be recorded by the installer for warranty purposes and future reference.

NAME OF OWNER: \_\_\_\_\_

ADDRESS: \_\_\_\_\_  
\_\_\_\_\_  
\_\_\_\_\_

PHONE: \_\_\_\_\_

NAME OF DEALER: \_\_\_\_\_

ADDRESS: \_\_\_\_\_  
\_\_\_\_\_  
\_\_\_\_\_

PHONE: \_\_\_\_\_

MODEL: \_\_\_\_\_

SERIAL NUMBER: \_\_\_\_\_

DATE OF PURCHASE: \_\_\_\_\_ (dd/mm/yyyy)

DATE OF INSTALLATION: \_\_\_\_\_ (dd/mm/yyyy)

INSTALLER'S SIGNATURE: \_\_\_\_\_  
\_\_\_\_\_

NAME OF INSTALLER: \_\_\_\_\_

ADDRESS: \_\_\_\_\_  
\_\_\_\_\_  
\_\_\_\_\_

PHONE: \_\_\_\_\_

MANUFACTURED BY:  
SHERWOOD INDUSTRIES LTD.  
6782 OLDFIELD RD. SAANICHTON, BC, CANADA V8M 2A3  
www.enviro.com  
June 29, 2016  
C-14579