



WARRANTY
REGISTRATION
IS QUICK AND EASY ONLINE.
enviro.com

Boston

Model: 1200-C & 1700C Free Standing

OWNERS MANUAL



SHERWOOD INDUSTRIES IS AN ENVIRONMENTALLY RESPONSIBLE COMPANY. THIS MANUAL IS PRINTED ON RECYCLED PAPER.

PLEASE SAVE THESE INSTRUCTIONS FOR FUTURE REFERENCE

INSTALLER:

Leave this manual with the wood stove.

CONSUMER:

Retain this manual for future reference.

Contact your local building or fire officials, or the authority having jurisdiction about restrictions and installation inspection requirements in your area.

PLEASE READ THIS ENTIRE MANUAL BEFORE INSTALLATION AND USE OF THIS WOOD BURNING ROOM HEATER. FAILURE TO FOLLOW THESE INSTRUCTIONS COULD RESULT IN PROPERTY DAMAGE, BODILY INJURY OR EVEN DEATH.

Tested & Listed By



Portland Oregon USA

OMNI-Test Laboratories, Inc.
1200 Report # 268-S-04b-2
1700 Report # 268-S-01b-2
ULC-S627-00

This heater meets the U. S. Environmental Protection Agencies emission limits for wood heaters sold after July 1st, 1990. Under specific conditions this heater has been shown to deliver heat at rates ranging from 11,479 to 34,196 BTU per hour for the 1200 and from 9,425 to 31,780 BTU per hour for the 1700.

50-2439

TABLE OF CONTENTS

Safety Precautions.....	3
Operating Instructions.....	4
Building Your Fire.....	6
Air Control.....	9
How It Works.....	10
Specifications.....	11
1200 Specifications.....	11
1700 Specifications.....	12
Clearances to Combustibles - 1200.....	13
Clearances to Combustibles - 1700.....	14
Dimensions - 1200.....	15
Dimensions - 1700.....	16
Installation.....	17
Removal From Pallet.....	17
Hearth Protection Examples.....	18
Outside Air Kit.....	21
Recommended Heights And Diameters For Flue Pipe.....	21
Chimney Installation Through Wall.....	22
Installation of A Listed, Factory Built Chimney.....	23
Masonry Chimney Installation.....	25
Masonry Fireplace Installation.....	26
Mobile Home Installation.....	26
Model 1200 Brick Placement & Tube Locations.....	28
Model 1700 Brick Placement & Tube Locations.....	29
C-Cast Ceramic Baffle Installation.....	30
Fan Wiring Diagrams.....	30
Optional Fan Installation.....	31
Disassembly.....	32
Removal of Cast Sides and Cast Door.....	32
Door Latch Adjustment.....	32
Rating Label.....	33
Parts List.....	34
Parts Diagram - Freestanding.....	35
Warranty.....	36
Installation Data Sheet.....	37

 **NATIONAL FIREPLACE INSTITUTE**
NFI
CERTIFIED
www.nficertified.org

We recommend that our woodburning hearth products be installed and serviced by professionals who are certified in the U.S. by the National Fireplace Institute® (NFI) as NFI Woodburning Specialists or who are certified in Canada by Wood Energy Technical Training (WETT).

 **Wood Energy Technical Training**
www.wettinc.ca

SAFETY PRECAUTIONS

FOR SAFE INSTALLATION AND OPERATION OF YOUR “ENVIRO” WOOD STOVE, PLEASE CAREFULLY READ THE FOLLOWING INFORMATION:

- **Please read this entire manual before you install and use your new woodstove. Failure to follow instructions may result in property damage, bodily injury or even death. Be aware that local Codes and Regulations may override some items in this manual. Check with your local inspector.**
- If this appliance is not properly installed, operated and maintained, a serious house fire could result. Makeshift materials during installation could also result in a serious house fire.
- **HOT WHILE IN OPERATION. KEEP CHILDREN, CLOTHING, AND FURNITURE AWAY. CONTACT MAY CAUSE SKIN BURNS.**
- Operate only with the door and ash plug tightly closed and burn wood directly on the stove hearth. Do not operate if the door glass is broken or a gasket is missing or damaged. Do not alter the combustion air control valves. Dangerous overfiring could occur which could ignite creosote in the chimney or cause a house fire.
- At least 12 square inches (77.4 cm²) of fresh outside air should be admitted into the room or directly to the stove through a 4 inch (10.16 cm) diameter pipe. For the stove to operate combustion-air must be supplied through either the bottom or the back of the unit.
- Do not burn coal or charcoal as there is danger of carbon monoxide being produced. **DO NOT USE CHEMICALS OR FLUIDS TO START THE FIRE. DO NOT BURN GARBAGE OR FLAMMABLE FLUIDS SUCH AS GASOLINE, GREASE, NAPHTHA OR ENGINE OIL.** Never let the stove become hot enough to get any part red or glowing red.
- Burning wet, unseasoned wood could cause excessive creosote accumulation in the flue pipe. When ignited, it could cause a chimney fire that could result in a serious house fire.
- Do not use grates, andirons or any other methods to support or raise the fire up off the hearth of the appliance.
- This appliance is tested to ULC-S627-00 Standard for Space Heaters for Use with Solid Fuel & UL 1482 -10 Standard for Safety for Solid-Fuel Type Room Heaters.
- In Canada the existing chimney must be lined to the termination for all masonry installs.
- A chimney connector shall not pass through an attic or roof space, closet or similar concealed space, or a floor, or ceiling.
- Where passage through a wall, or partition of combustible construction is desired, the installation shall conform to CAN/CSA-B365, Installation Code for Solid-Fuel-Burning Appliances and Equipment.
- **DO NOT CONNECT TO OR USE IN CONJUNCTION WITH ANY AIR DISTRIBUTION DUCTWORK UNLESS SPECIFICALLY APPROVED FOR SUCH INSTALLATIONS.**
- In the event of component failure, only manufacturer specified replacement parts may be used.
- **DO NOT CONNECT THIS UNIT TO A CHIMNEY FLUE SERVING ANOTHER APPLIANCE.**
- Ensure that the ash plug is installed over the ash dump hole.
- Do not open the ash pan compartment while the unit is burning. Allow unit to fully cool before touching the ash pan latch.
- Do not clean glass when unit is hot.

OPERATING INSTRUCTIONS

FIRST START

When first installed, the chimney, firebricks and steel are cold and it usually takes several hours on a fairly high burn for them to become hot and dry enough for the stove to function well. We recommend during the unit's first burn that a door and window are opened to vent the smoke and fumes created from the unit's paint curing. The paint will smell a little for the first burn or two as it cures.

DISPOSAL OF ASHES:

The Boston freestanding models are equipped with an ash plug in the firebox and an ash drawer. Lift the ash plug out and push the ashes that have accumulated into the hole; the ashes will then drop into the Ash Pan. Ensure that the ash plug is seated properly before relighting the unit. When the Ash Pan is ready to be emptied, fully open the main door on the unit and then open the lower latch on the Cast Ash Drawer. The Cast Ash Drawer will lower down and the Ash Pan will be accessible (see Figure 1). Ashes should be placed in a steel container with a tight fitting lid. The closed container of ashes should be moved outdoors immediately. If the ashes are disposed of by burial in soil or otherwise locally disposed, they should be retained in the closed container until all cinders have thoroughly cooled. Other waste shall not be placed in this container. Prior to burning the unit, re-insert the Ash Pan into the unit and close the Cast Ash Drawer, ensuring that the latch is closed securely.

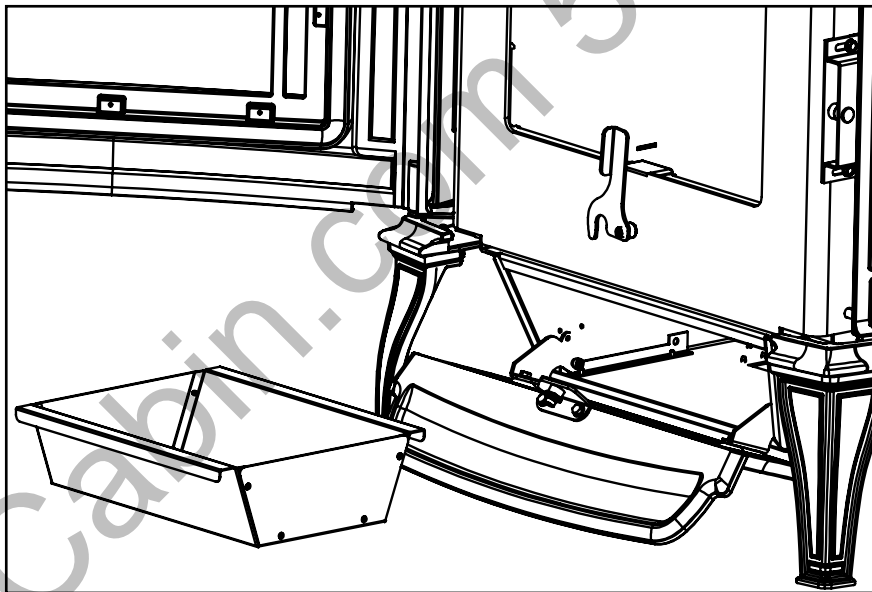

Figure 1: Ash Pan Removal

FAN OPERATION:

This unit has been approved for operation with or without the optional fan supplied by the manufacturer. On medium or high burns, using a fan will increase the heat transfer slightly. Route the power supply cord along the floor behind the stove where it will remain cool.

1. Plug the fan assembly into a standard three prong grounded electrical receptacle.
2. Turn the rotary fan controller to the desired setting. Once operating temperature is reached, the fan temperature sensor will turn the fan on. When the unit cools down, the fan temperature sensor will shut the fan off automatically.

OPERATING INSTRUCTIONS

REPLACING THE GLASS:

Never strike or slam the door, hit the glass or let burning wood rest against it. If the glass cracks when the fire is burning, do not open the door until the fire is out and do not operate the stove again until the glass has been replaced. If the glass is damaged in any way, a factory replacement is required (see "PARTS LIST"). To replace the glass, remove the steel retaining clips and all loose glass. Replace only with Neoceram 5 mm glass 16.61" (422 mm) x 10.63" (270 mm) and wrap the edges with 0.125" (3.2 mm) x 0.5" (13 mm) self-adhesive fiberglass gasket.

Wear gloves when handling damaged glass door assembly to prevent personal injury. When the glass door assembly is being transported, it must be wrapped in newsprint and tape and/or a strong plastic bag.

The glass must be purchased from an ENVIRO dealer. No substitute materials are allowed.

FIRE EXTINGUISHER AND SMOKE DETECTION:

All homes with a solid fuel burning stove should have at least one fire extinguisher in a central location known to all in the household and a smoke detection device in the room containing the stove. If it sounds the alarm, correct the cause but do not deactivate. You may choose to relocate the smoke detection device within the room; DO NOT REMOVE THE SMOKE DETECTOR FROM THE ROOM.

CREOSOTE - FORMATION AND NEED FOR REMOVAL:

When wood is burned slowly, it produces tar and other organic vapors, which combine with expelled moisture to form creosote. The creosote vapors condense in the relatively cool chimney of a slow-burning fire. As a result, creosote residue accumulates on the flue lining. When ignited this creosote makes an extremely hot fire. The chimney connector and chimney should be inspected bi-weekly during the heating season to determine if a creosote buildup has occurred. If creosote has accumulated (3mm or more) it should be removed to reduce the risk of a chimney fire.

MAINTENANCE:

At the end of each heating season clean the chimney and the smoke pipe. If soot has accumulated above the top baffle bricks, remove, clean, and then replace them. If a secondary air tube is badly corroded, replace it. Replace worn door gaskets and broken bricks as needed.

FAILURE TO INSPECT AND CLEAN YOUR CHIMNEY SYSTEM REGULARLY CAN RESULT IN A CHIMNEY FIRE, WHICH COULD DAMAGE THE CHIMNEY OR CAUSE A HOUSE FIRE.

CHIMNEY OR RUN AWAY FIRE:

1. Call local fire department (or dial 911)
2. Close the draft fully
3. Examine the flue pipes, chimney, attic, and roof of the house, to see if any part has become hot enough to catch fire. If necessary, spray with fire extinguisher or water from the garden hose.
4. Do not operate the stove again until you are certain the chimney and its lining have not been damaged.

OPERATING INSTRUCTIONS

BUILDING YOUR FIRE:

Proper operation of your stove will help to ensure safe, efficient heating. Please take a few moments to review these simple operating procedures.

IMPORTANT: Please be aware when loading your stove that the air tubes in the rear are lower.

1. Fuel Selection:

This stove is designed to burn natural wood only. Higher efficiencies and lower emissions generally result when burning air-dried seasoned hardwoods, as compared to softwoods or too green or freshly cut hardwoods. **DO NOT BURN** the following: treated wood, coal, garbage, solvents, colored papers or trash. Burning these may result in the release of toxic fumes and may poison or render the secondary air tubes ineffective. Burning coal, cardboard or loose paper can produce soot, or large flakes of char or fly ash that can coat the combustor, causing smoke spillage into the room, and rendering the combustor ineffective.

2. Building/Maintaining a Fire:

- a) Open the primary air slide by pulling it all the way to the right.
- b) Place a base of crumpled uncolored newspaper in the bottom of the stove. Lay pieces of kindling on top of the newspaper and light it.

CAUTION: "Never use gasoline, gasoline-type lantern fuel, kerosene, charcoal lighter fluid, or similar liquids to start or "freshen up" a fire in this heater. Keep all such liquids well away from heater while it is in use.

- c) As the kindling begins to burn, add several larger pieces of wood until the fire is burning well. At this point, regular size logs may be added.

NOTE: Until the fire is burning well, leave the air controls fully open.

- d) Regulate the heat output of the stove by adjusting the air controls to allow a larger fire and vice versa. A short period of experimentation with the control settings will allow you to regulate the heat output to keep your home comfortable.

Do not use a grate or elevate the fire. Build wood fire on the stove firebox hearth floor.

3. Refueling the Stove:

Use a long pair of gloves (barbecue gloves) when feeding the fire because these stoves burn at the front. They are clean and efficient but they are also very hot and gloves are useful. Keep a small steel shovel and whisk nearby for moving a log or lifting a fallen ember and for keeping the hearth clean.

- a) Before attempting to add fuel to the stove, **OPEN** the damper control fully by pulling it all the way out. This allows the chimney to carry away the additional smoke, which occurs when the door is open.

- b) **DO NOT OVERLOAD THE STOVE.** Normally, three or four logs will provide heat for several hours. Never operate this stove where portions glow red hot.

- c) **DO NOT OVERFIRE.** If the heater or chimney connector glows, you are overfiring. Overfiring could ignite creosote in the chimney and cause a house fire.

- d) **CAUTION:** DO NOT PLACE FUEL OR COMBUSTIBLE MATERIAL WITHIN SPACE HEATER INSTALLATION CLEARANCES OR WITHIN THE SPACE REQUIRED FOR CHARGING AND ASH REMOVAL. LOGS SHOULD BE KEPT IN A BIN OR CONTAINER TO REDUCE THE RISK OF LOGS ROLLING INTO THE UNIT'S CLEARANCES.

- e) **KEEP THE ASH LIP CLEAR OF EMBERS AND ASH.** If the door is closed with debris in the way, the door gasket seal could be compromised.

OPERATING INSTRUCTIONS

4. For Maximum Efficiency:

When the stove is hot, load it fully to the top of the door opening and burn at medium low settings. When the fuel is mostly consumed, leaving a bed of red coals, repeat the process. Maximum heat for minimum fuel occurs when the stove top temperature is between 250°F (120°C) and 550°F (290°C). The most likely causes of dirty glass are: not enough fuel to get the stove thoroughly hot, burning green or wet wood, closing the draft until there is insufficient air for complete combustion, or a weak chimney draw. Indeed, the cleanness of the glass is a good indicator of the stove operating efficiently.

Helpful Hints Worth Repeating

1. Helpful advice on the correct way to start your fire.

- a) You will need small pieces of dry wood, called kindling, and paper. Use only newspaper or paper that has not been coated or had other materials glued or applied to it. Never use coated (typically advertising flyers) or coloured paper.
- b) Always open the door of the wood stove slowly to prevent suction and drawing smoke into the room.
- c) Crumple several pieces of paper and place them in the center of the firebox and directly onto the firebricks of the wood stove. Never use a grate to elevate the fire.
- d) Place small pieces of dry wood (kindling) over the paper in a “teepee” manner. This allows for good air circulation, which is critical for good combustion.
- e) Light the crumpled paper in 2 or 3 locations. Note: It is important to heat the air in the stovepipe for draft to start.
- f) Fully open the air controls of the wood stove and close the door until it is slightly open, allowing for much needed air to be introduced into the firebox. Never leave the door fully open, as sparks from the kindling may fly out of the stove, causing damage or injury. As the fire begins to burn the kindling, some additional kindling may be needed to sustain the fire. DO NOT add more paper after the fire has started.
- g) Once the kindling has started to burn, add some smaller pieces of seasoned, dry firewood. Note: Adding large pieces at the early stages will only serve to smother the fire. Continue adding small pieces of seasoned dry firewood, keeping the door slightly open until each piece starts to ignite. Remember to always open the door slowly between placing wood into the fire.
- h) Once the wood has started to ignite and the smoke has reduced, close the wood stove door fully. The reduction of smoke is a good indication that the draft in the chimney has started and good combustion is now possible. Larger pieces of seasoned, dry firewood can now be added when there is sufficient space in the firebox. Adjust the air control setting to desired setting. Note: The lower the air control setting, the longer the burn time of your firewood.

2. What type of wood is best to use as firewood?

Both hardwood and softwood burn well in this stove. Both woods contain about 8,000 BTU/lb (18,570 KJ/Kg), but hardwood is generally more dense, will weigh more per cord, and burns a little slower and longer. Cutting firewood so that it will fit horizontally, front to back, makes it easier loading and less likely for the fuel to roll on the glass. Except for a cold start, there is no need to crisis-cross the logs. Ideal length for the logs used in the 1200-C would be about 16" (381 mm) but it can burn pieces up to 18" long. Ideal length for the logs used in the 1700-C would be about 18" (381 mm) but it can burn pieces up to 20" long logs. Burn only dry, seasoned wood. It produces more heat and less soot or creosote. Freshly cut wood has about 50% moisture. A 10 pound (4.5 Kg) log contains 5 pounds (2.3 Kg) of water. To season firewood, split and stack it so that air can get to all parts of the wood. Burn beach wood only if its salt content has been washed away in a season of rain and then the wood dried. To prevent smoke

OPERATING INSTRUCTIONS

spillage when refueling, open the door slowly.

3. What does dry, seasoned wood mean?

Wood that has been dried for a period of one year in a well-ventilated and sheltered area would be considered dry, seasoned wood. Wood from slow-growing trees is generally considered better than wood from fast-growing trees. To season firewood, split and stack it so that air can get to all parts of the wood.

4. Will following the above-listed steps for starting a fire mean perfect results every time?

The quick answer is 'most of the time'. There are many variables that may affect your success when starting a fire. Most of those variables and how to deal with them will be learned through experience. Your ability to start a good fire will significantly increase with time and patience. Some of the reasons for poor stove performance will be covered in the next section of these instructions.

5. Why can't I get the fire lit?

Damp or wet wood and poor drafts are the main reasons for poor results in starting a fire. Always use dry, seasoned wood for your fire. Even wood dried for two years will be difficult to ignite if it has become wet.

6. Is it normal for soot to cover the glass at the beginning of a fire?

Your stove has been built with an air-wash system that will help keep the glass clear when the firebox has reached a good operating temperature and has a good draft. Normally, a hot stove will keep the glass clean, but if you must clean the glass, use a soft cloth with no abrasive and clean only when the unit is cold. Cold firebox temperature and poor draft cause sooting of the glass. Once the firebox temperature and the draft increase, the soot will burn off.

7. What is draft?

Draft is the ability of the chimney to exhaust or draw smoke produced during the normal combustion process. Too much draft may cause excessive temperatures in the appliance and may damage the appliance. Inadequate draft may cause backpuffing or "plugging" of the chimney. There is a certain amount of draft that is required to allow for your stove to function at its' highest efficiency. A water column gauge can be used to reference this amount.

8. What can cause a poor draft?

The most common factors for poor draft are:

- a) Air supply
- b) Environmental conditions
- c) Cold chimney temperature
- d) Poor chimney installation and maintenance
- e) Atmospheric pressure

- a) Air supply – Inside the home, normal household appliances such as clothes dryers and forced-air furnaces compete for air, resulting in air starvation to the fire. This creates a condition in the house known as negative pressure. When a house experiences negative pressure, the combustion gases can be drawn from the chimney and into the house. This condition is commonly referred to as down-

OPERATING INSTRUCTIONS

drafting. Increased amounts of insulation, vinyl windows, extra caulking in various places and door seals can all keep heat in but may also make a home too airtight. An easy way to stop negative pressure in a home is to crack a window in the room containing the stove.

- b) Environmental Conditions - High trees, low-lying house location such as in a valley, tall buildings or structures surrounding your house and windy conditions can cause poor draft or down-drafting.
- c) Cold Chimney Temperature - Avoid cold chimney temperatures by burning a hot fire for the first fifteen to forty minutes, being careful not to over-fire the stove. If any part of the chimney or parts of the stove start to glow, you are over-firing the stove. Where possible, install a temperature gauge on the chimney so temperature drops can be seen.
- d) Chimney Installation and Maintenance - Avoid using too many elbows or long horizontal runs. Too short a chimney can cause difficult start-up, dirty glass, back smoking when door is open, and even reduced heat output. Too tall a chimney may prompt excessive draft, which can result in very short burn times and excessive heat output. If in doubt, contact a chimney expert and/or chimney manufacturer for help. Clean chimney, rain caps and especially the spark arrestor regularly, to prevent creosote build-up, which will significantly reduce chimney draw and possibly a chimney fire.

Note: These instructions are intended as an aid and do not supercede any local, provincial or state requirements. Check with officials or authorities having jurisdiction in your area.

AIR CONTROL:

The air wash and pilot air (control the amount of air to the fire) are controlled by the rod located on the right side of the unit. To increase your air, pull the rod out and to decrease, push the rod in. All the units have a secondary air that flows through the tubes at the top of the firebox, just below the baffles.

Pull this control all the way out when first starting the stove. Once the fire has been established you may adjust this control to set the burn rate of the fire. If this damper is closed at first start-up, the fire will burn very slowly and could soot the appliance.

When shutting down the stove, fully open the air control. This allows the chimney temperatures to remain as high as possible for as long as possible. Cold chimney temperatures create creosote.

Warning - This adjustment should not be altered for increased firing for any reason.

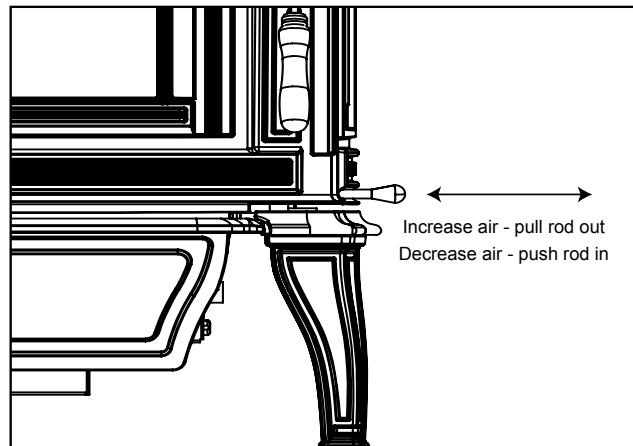

Figure 2: Air Control Rod.

OPERATING INSTRUCTIONS

How It Works:

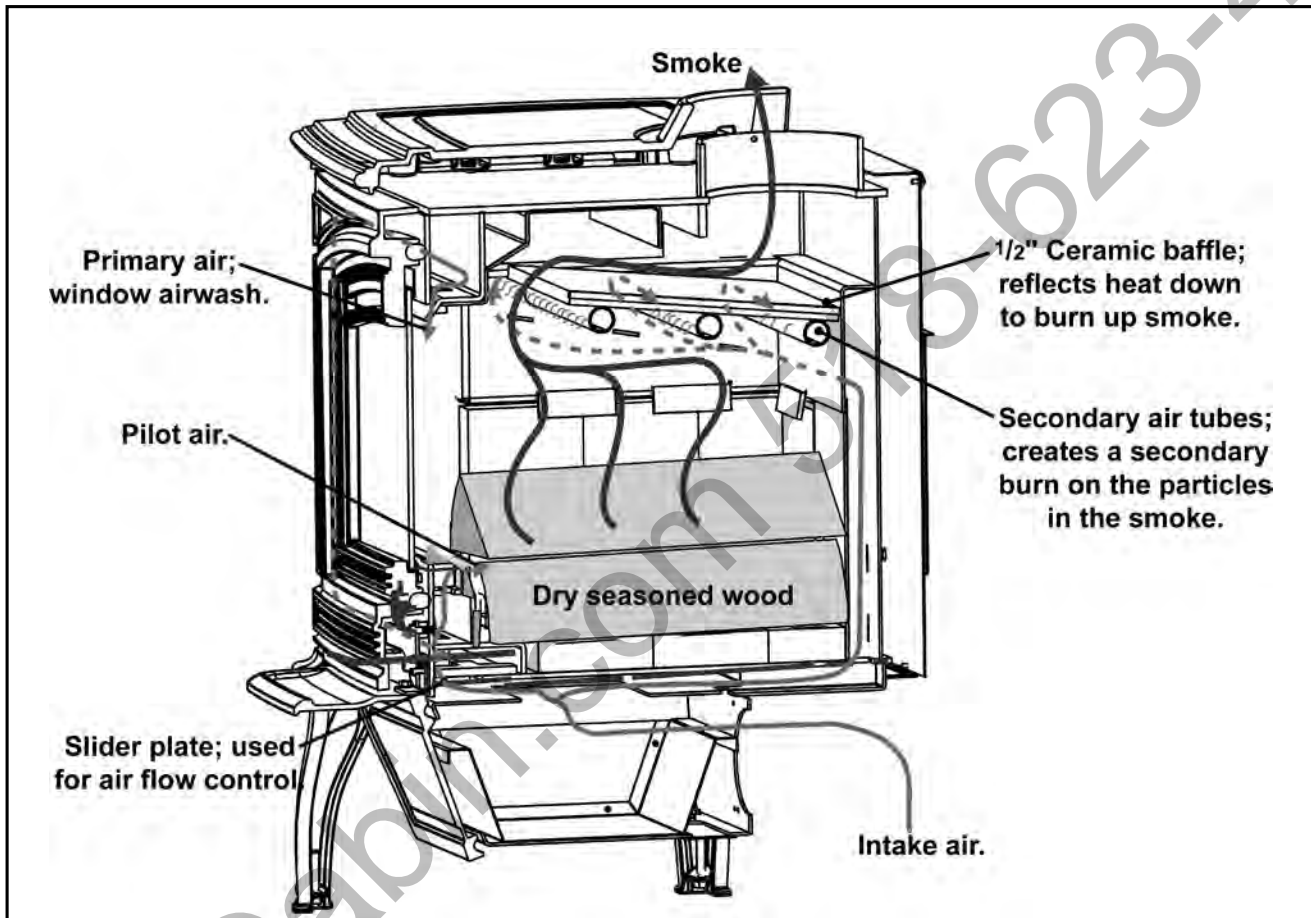

Figure 3: 1200 Air Flow Path.

SPECIFICATIONS

1200 SPECIFICATIONS:

Model	1200 Freestanding
Width x Depth	30" x 25" (762 mm x 635 mm)
Height with legs	31.75" (806mm)
Fire box size (depth x width x height)	16.1" x 18.25" x 11.15" (409 mm x 464 mm x 283 mm)
Capacity	1.85 feet ³ (0.0526 meter ³)
* Approximate heating area	800 - 1,500 feet ² (74.3 - 139.4 meter ²)
**E.P.A. output rating	11,479 to 34,196 BTU/hour (3,361 to 10,013 watt)
*Duration on low burn	6 -10 hours
Weight with packaging	335 lb (151.95 Kg)
E.P.A. Emissions	3.3 grams/hour (0.116 oz/hour)
Rating Label Location	Back of Unit

Table 1: 1200 General Information.

SPECIFICATIONS

1700 SPECIFICATIONS:

Model	1700 Freestanding
Width x Depth	30" x 29" (762 mm x 736 mm)
Height with legs	31.75" (806mm)
Fire box size (depth x width x height)	20.65" x 18.25" x 11.95" (525 mm x 464 mm x 304 mm)
Capacity	2.5 feet ³ (0.0708 meter ³)
* Approximate heating area	1,000 - 2,200 feet ² (92.9 - 205.4 meter ²)
**E.P.A. output rating	9,425 to 31,780 BTU/hour (2,760 to 9,306 watt)
*Duration on low burn	8 - 12 hours
Weight with packaging	420 lb (190.51 Kg)
E.P.A. Emissions	4.48 grams/hour (0.158 oz/hour)
Rating Label Location	Back of Unit

Table 1b: 1700 General Information.

SPECIFICATIONS

CLEARANCES TO COMBUSTIBLES - 1200 FREESTANDING:

MAINTAIN THESE MINIMUM CLEARANCES TO UNSHIELDED COMBUSTIBLES*

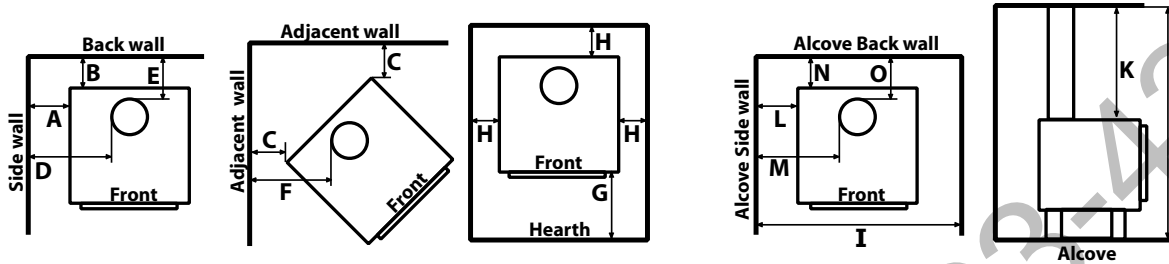

Table 2: 1200 Freestanding Clearance to Combustibles.

		Single Wall Pipe	Double Wall Pipe**	Top vent out back wall with min. 24" (610 mm) vertical rise; double wall
A	From side wall to side of unit	13" (330 mm)	13" (330 mm)	14" (356 mm)
B	From rear wall to back of unit	11" (279 mm)	10" (254 mm)	12" (305 mm)
C	From adjacent wall to corner of unit	9" (229 mm)	8" (203 mm)	
D	From side wall to collar	22" (559 mm)	22" (559 mm)	23" (584 mm)
E	From rear wall to collar	14" (356 mm)	13" (330 mm)	15" (381 mm)
F	From adjacent wall to collar	17½" (445 mm)	16½" (419 mm)	
G	† From door opening to edge of hearth pad	USA 16" (406 mm) CND 18" (450 mm)	USA 16" (406 mm) CND 18" (450 mm)	USA 16" (406 mm) CND 18" (450 mm)
H	† From side/back of unit to edge of hearth pad	USA 6" (152 mm) CND 8" (200 mm)	USA 6" (152 mm) CND 8" (200 mm)	USA 6" (152 mm) CND 8" (200 mm)
Alcove (48" [1220 mm] Deep)				
I	Total Width		55" (1397 mm)	
J	Total Height		78" (1981 mm)	
K	Top of stove to ceiling		49" (1245 mm)	
L	Side wall to stove		15" (381 mm)	
M	Side wall to pipe		24" (610 mm)	
N	Back wall to unit		12" (305 mm)	
O	Back wall to pipe		15" (381 mm)	

SPECIFICATIONS

CLEARANCES TO COMBUSTIBLES - 1700 FREESTANDING:

MAINTAIN THESE MINIMUM CLEARANCES TO UNSHIELDED COMBUSTIBLES*

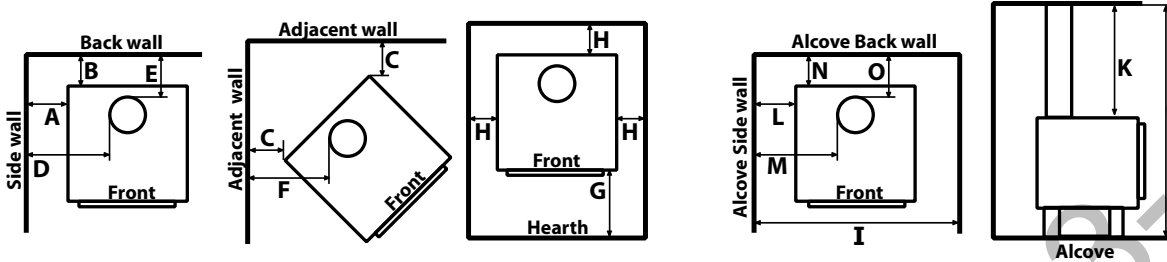

Table 10: 1700 Freestanding Clearance to Combustibles.

		Single Wall Pipe	Double Wall Pipe**	Top vent out back wall with min. 24" (610 mm) vertical rise; double wall
A	From side wall to side of unit	20" (508 mm)	13" (330 mm)	11" (279 mm)
B	From rear wall to back of unit	12" (305 mm)	10" (254 mm)	13" (330 mm)
C	From adjacent wall to corner of unit	10" (254 mm)	8½" (216 mm)	
D	From side wall to collar	29" (737 mm)	22" (559 mm)	20" (508 mm)
E	From rear wall to collar	15" (381 mm)	13" (330 mm)	16" (406 mm)
F	From adjacent wall to collar	18½" (470 mm)	17" (432 mm)	
G	† From door opening to edge of hearth pad	USA 16" (406 mm) CND 18" (450 mm)	USA 16" (406 mm) CND 18" (450 mm)	USA 16" (406 mm) CND 18" (450 mm)
H	† From side/back of unit to edge of hearth pad	USA 6" (152 mm) CND 8" (200 mm)	USA 6" (152 mm) CND 8" (200 mm)	USA 6" (152 mm) CND 8" (200 mm)
Alcove (48" Deep)				
I	Total Width		51" (1295 mm)	
J	Total Height		72" (1829 mm)	
K	Top of stove to ceiling		44" (1118 mm)	
L	Side wall to stove		13" (330 mm)	
M	Side wall to pipe		22" (559 mm)	
N	Back wall to unit		8" (203 mm)	
O	Back wall to pipe		11" (279 mm)	

CAUTION: An uninsulated smoke pipe must not pass through an attic, roof space, closet or similar concealed space, or through a floor, ceiling, wall, or partition, or any combustible construction.

† **FLOOR PROTECTION:** If a stove is installed on a combustible floor, it must be on a NON-COMBUSTIBLE hearth pad

* ALL CLEARANCES CAN BE REDUCED WITH SHIELDING ACCEPTABLE TO THE LOCAL AUTHORITY.

**DOUBLE WALL:

IN CANADA: Any ULC-S629 listed chimney system with the accompanying listed double wall vent connector.

IN U.S.A.: Any UL 103 HT listed chimney system with the accompanying listed double wall vent connector.

SPECIFICATIONS

DIMENSIONS - 1200 FREESTANDING:

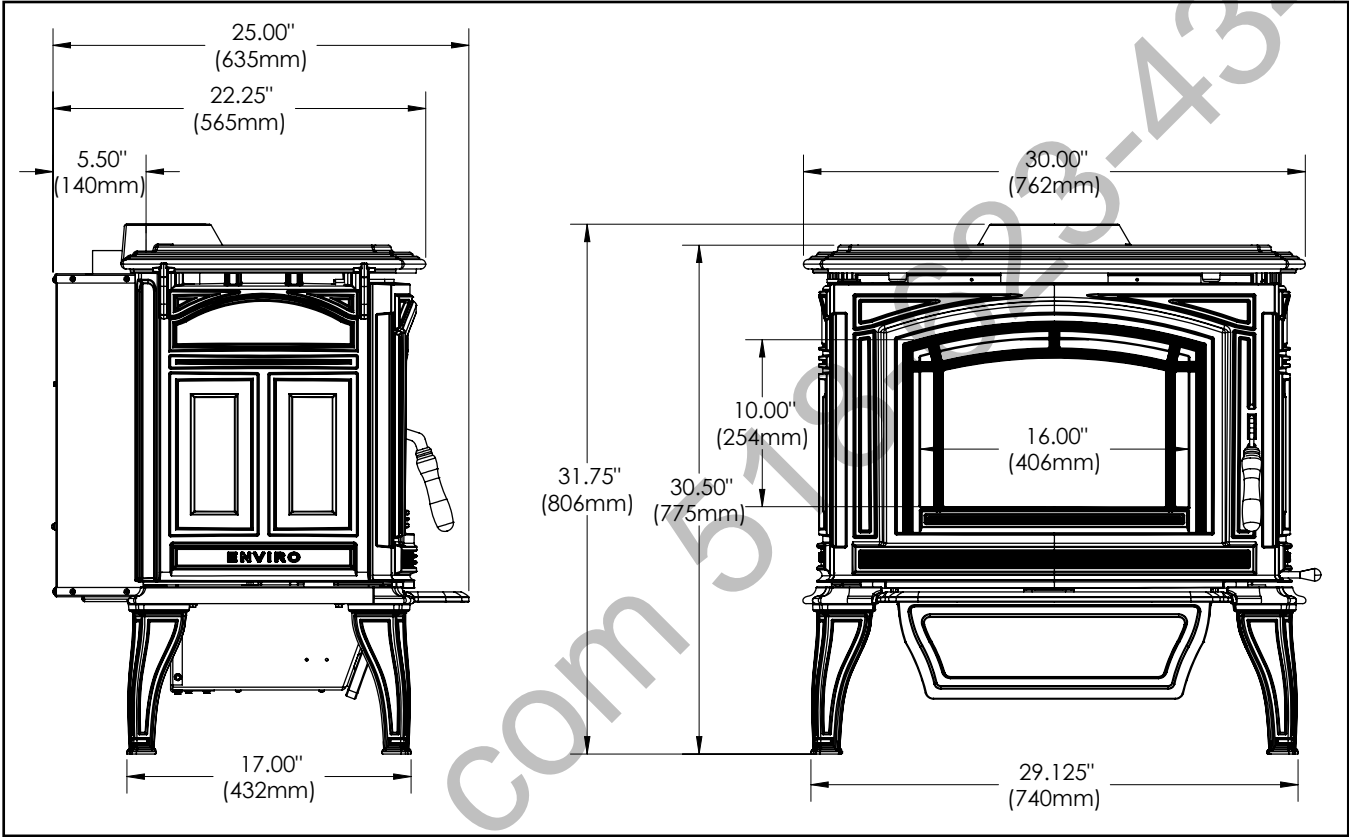

Figure 4: 1200 Freestanding Dimensions.

CozyCabin.com 22-4349

SPECIFICATIONS

DIMENSIONS - 1700 FREESTANDING:

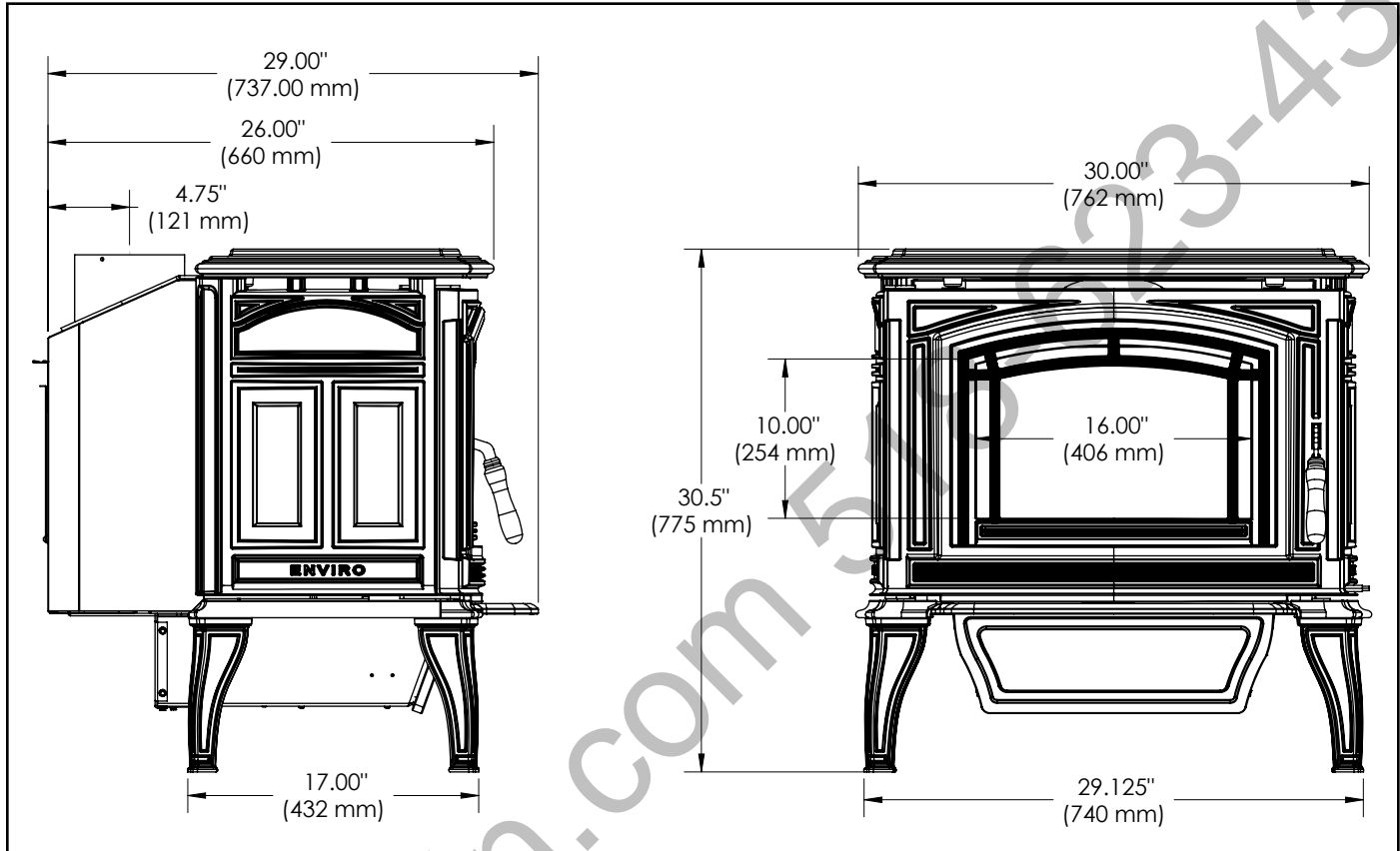

Figure 4b: 1700 Freestanding Step Top Dimensions.

INSTALLATION

REMOVAL FROM PALLET:

- Remove the screws which are securing the shipping brackets to the unit.
- Remove the lag bolts and discard the brackets.

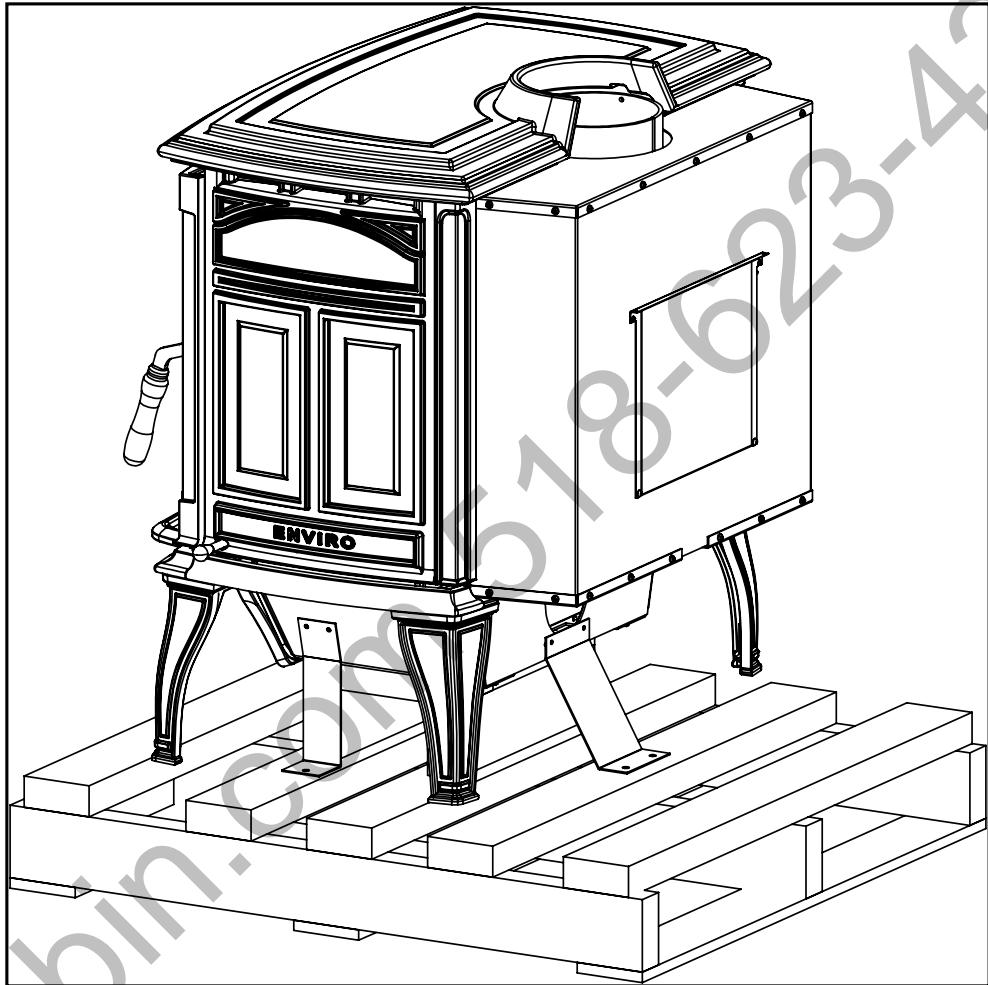

Figure 5: Bolts to remove.

INSTALLATION

HEARTH PROTECTION EXAMPLES:

Table 11: Examples of Hearth Pad Sizing Using Clearances From Tables 9 &10 (refer to Figures 22 & 23).

	Canada		USA	
	1200	1700	1200	1700
(A) Minimum Width	40½" (1028mm)		36½" (926mm)	
(B) Minimum Depth	46" (1168mm)	50½" (1283mm)	42" (1067mm)	46½" (1181mm)
OPTIONAL - Corner removal				
(C) Maximum Front Corners - Adjacent	8¾" (314mm)		6¾" (171mm)	
(D) Maximum Back Corners - Adjacent	6¼" (160mm)		5⅛" (130mm)	
(E) Maximum Front Corners - Diagonal	12¾" (314mm)		9½" (242mm)	
(F) Maximum Back Corners - Diagonal	8⅞" (227mm)		7¼" (185mm)	
(G) Minimum Width remaining without corners - Front	23" (583mm)		23" (583mm)	
(H) Minimum Width remaining without corners - Back	27⅞" (707mm)		26⅞" (665mm)	

Table 12: Examples of Parallel Installation Using Clearances From Tables 9 &10 (refer to Figure 22).

	Model	Country	(I) Far Edge of Hearth Pad to Side Wall - Minimum	(J) Front of Hearth Pad to Back Wall - Minimum
Single Wall Pipe	1200	Canada	45½" (1156mm)	49¼" (1252mm)
		USA	43½" (1104mm)	47¼" (1201mm)
	1700	Canada	52½" (1333mm)	54¾" (1391mm)
		USA	50½" (1283mm)	52¾" (1340mm)
Double Wall Pipe	1200	Canada	45½" (1156mm)	48¼" (1226mm)
		USA	43½" (1104mm)	46¼" (1175mm)
	1700	Canada	45½" (1156mm)	52¾" (1340mm)
		USA	43½" (1104mm)	50¾" (1290mm)
Top vent out back wall with min. 24" (610mm) vertical rise; double wall	1200	Canada	46½" (1181mm)	50¼" (1277mm)
		USA	44½" (1129mm)	48¼" (1226mm)
	1700	Canada	43½" (1104mm)	55¾" (1417mm)
		USA	41½" (1053mm)	53¾" (13466mm)

Non combustible floor protection must be under the chimney connector and 2 inches (50.8 mm) beyond each side.

INSTALLATION

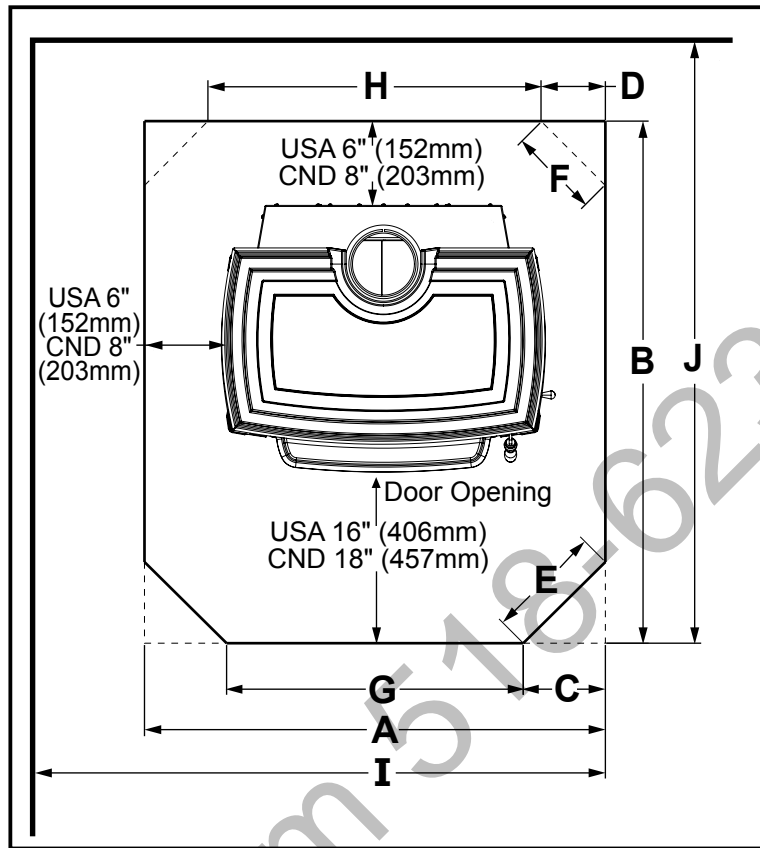

Figure 6: General Parallel Installation
(refer to Tables 11 & 12).

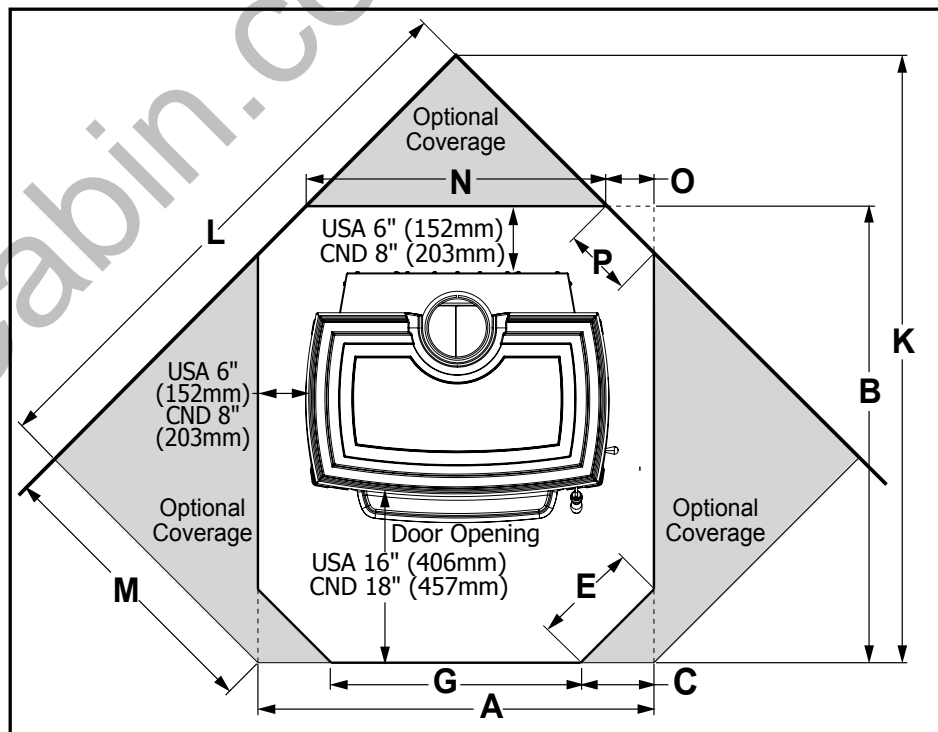

Figure 7: General Corner Installation (refer to Tables 11 & 13).

INSTALLATION

Table 13: Examples of Corner Installation Using Clearances From Tables 9 & 10 (refer to Figures 23 & 24).

		(K) Front of Hearth Pad to Corner	(L) Adjacent Wall	(M) Edge of Hearth Pad to Adjacent Wall	(N) Width at back of Hearth Pad	(O) Back Corner Removed - Adjacent	(P) Back Corner Removed - Diagonal	
Single Wall Pipe	1200	Canada	57 ⁵ / ₈ " (1465mm)	29 ¹ / ₈ " (738mm)	30 ⁵ / ₈ " (779mm)	4 ⁷ / ₈ " (124mm)	7 ¹ / ₈ " (182mm)	
		USA	59 ³ / ₈ " (1507mm)	54 ⁷ / ₈ " (1393mm)	29 ¹ / ₈ " (738mm)	34 ⁵ / ₈ " (881mm)	7 ⁸ / ₈ " (23mm)	1 ¹ / ₄ " (32mm)
	1700	Canada	67 ¹ / ₄ " (1708mm)	61 ⁷ / ₈ " (1571mm)	33 ¹ / ₄ " (844mm)	33 ¹ / ₂ " (851mm)	3 ¹ / ₂ " (88mm)	4 ⁷ / ₈ " (125mm)
		USA	65 ¹ / ₄ " (1657mm)	59" (1499mm)	33 ¹ / ₄ " (844mm)	36 ¹ / ₂ " (926mm)	0" (0mm)	0" (0mm)
Double Wall Pipe	1200	Canada	59 ⁷ / ₈ " (1522mm)	56 ⁵ / ₈ " (1439mm)	28 ¹ / ₈ " (713mm)	27 ⁷ / ₈ " (707mm)	6 ¹ / ₄ " (160mm)	8 ⁷ / ₈ " (227mm)
		USA	57 ⁷ / ₈ " (1471mm)	53 ⁷ / ₈ " (1368mm)	28 ¹ / ₈ " (713mm)	31 ⁷ / ₈ " (809mm)	2 ¹ / ₄ " (59mm)	3 ¹ / ₄ " (83mm)
	1700	Canada	65 ¹ / ₈ " (1654mm)	60 ³ / ₈ " (1533mm)	31 ³ / ₄ " (806mm)	29 ¹ / ₄ " (743mm)	5 ⁵ / ₈ " (142mm)	7 ⁷ / ₈ " (201mm)
		USA	63 ¹ / ₈ " (1603mm)	57 ¹ / ₂ " (1461mm)	31 ³ / ₄ " (806mm)	33 ¹ / ₄ " (845mm)	1 ⁵ / ₈ " (41mm)	2 ¹ / ₄ " (59mm)

INSTALLATION

OUTSIDE AIR KIT:

It is mandatory to use outside air for installations in mobile homes.

A 4" (10.2 cm) fresh air adaptor kit is available. This kit can be installed on the back of the Ash Box. If outside air is to be used in conjunction with the convection fan kit, there is a separate outside air adapter which connects to the bottom of the Ash Box. Refer to the Parts List.

Place the ¼" mesh screen behind the fresh air adaptor (as shown to right).

Fresh air connection to the unit must be a non-combustible pipe -

Example: 4" (10.2 cm) single wall aluminum flex pipe.

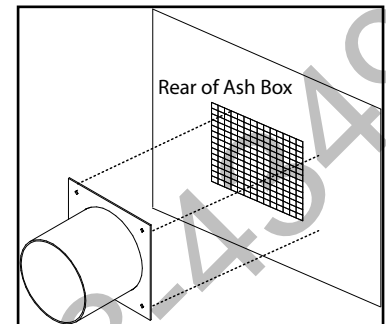

Figure 8: Fresh Air Adaptor

RECOMMENDED HEIGHTS AND DIAMETERS FOR FLUE PIPE:

The minimum flue pipe height at sea level is 12 feet (3.7 m) straight up from top of the unit. For every 1000 feet (305 m) above sea level, 4% could be added to the overall height. Use Tables 14, 15, and 16 to calculate the required vertical rise required.

Table 6: Recommended Height for Flue Pipe.

Elevation above sea level	Minimum recommended flue pipe height for # of elbows (Note: No more than 2 offsets (4 elbows) can be used. 2x45°=1x90°)						
	feet	0	2 x 15°	4 x 15°	2 x 30°	4 x 30°	2 x 45°
0-1000	12.0	12.7	13.3	13.3	14.7	14.0	16.0
1000-2000	12.5	13.2	13.8	13.8	15.3	14.6	16.6
2000-3000	13.0	13.7	14.4	14.4	15.9	15.1	17.3
3000-4000	13.4	14.2	14.9	14.9	16.5	15.7	17.9
4000-5000	13.9	14.7	15.4	15.4	17.1	16.2	18.6
5000-6000	14.4	15.2	16.0	16.0	17.6	16.8	19.2
6000-7000	14.9	15.7	16.5	16.5	18.2	17.4	19.8
7000-8000	15.4	16.3	17.0	17.0	18.8	17.9	20.5
8000-9000	15.8	16.8	17.6	17.6	19.4	18.5	21.1
9000-10000	16.3	17.3	18.1	18.1	20.0	19.0	21.8
meters	0	2 x 15°	4 x 15°	2 x 30°	4 x 30°	2 x 45°	4 x 45°
0-305	3.7	3.9	4.1	4.1	4.5	4.3	4.9
305-610	3.8	4.0	4.2	4.2	4.6	4.4	5.1
610-915	4.0	4.2	4.4	4.4	4.8	4.6	5.3
915-1220	4.1	4.3	4.6	4.6	5.0	4.8	5.5
1220-1525	4.2	4.5	4.7	4.7	5.2	4.9	5.7
1525-1830	4.4	4.6	4.9	4.9	5.4	5.1	5.9
1830-2135	4.5	4.8	5.0	5.0	5.5	5.3	6.0
2135-2440	4.7	4.9	5.2	5.2	5.7	5.5	6.2
2440-2745	4.8	5.1	5.4	5.4	5.9	5.6	6.4
2745-3050	5.0	5.3	5.5	5.5	6.1	5.8	6.6

Table 7: Distance to add to overall vertical height.

Part used	Distance to add	
	feet	meters
45° elbow	1.0	0.3
90° elbow	2.0	0.6
"T"	3.0	0.9
1 ft (0.3m) of horizontal run	2.0	0.6

Table 8: Examples of calculating overall vertical height required.

Height	
sea level with 2 x 30° elbows	13.3 ft (4.1 m)
one "T"	3.0 ft (0.9 m)
1½ ft (0.6 m) horizontal run	3.0 ft (0.9 m)
Total 1	19.3 ft (5.9 m)
4000-5000 ft (1220-1525 m) above sea level	13.9 ft (4.2 m)
one "T"	3.0 ft (0.9 m)
2 ft (0.6 m) horizontal run	4.0 ft (1.2 m)
Total 2	20.9 ft (6.3 m)

We recommend the use of a 6" (150mm) diameter flue pipe. However, the CSA-B365 and the WETT Training Manual state that the flue pipe may be reduced in cross-sectional area provided that the installer ensures sufficient draft is available at the appliance.

INSTALLATION

CHIMNEY INSTALLATION THROUGH WALL:

Here are four (4) methods of combustible wall chimney connector pass-throughs. Information was provided from NFPA 211.

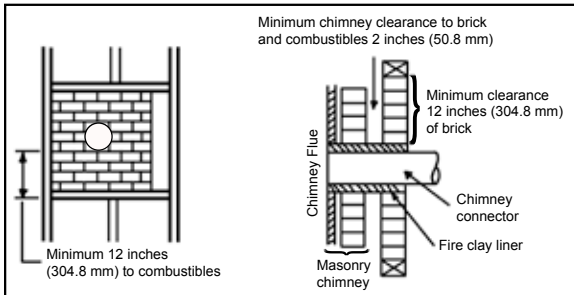

Figure 9: Chimney Through Wall - Method A.

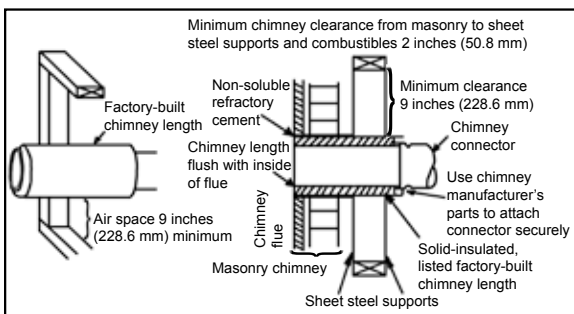

Figure 10: Chimney Through Wall - Method B.

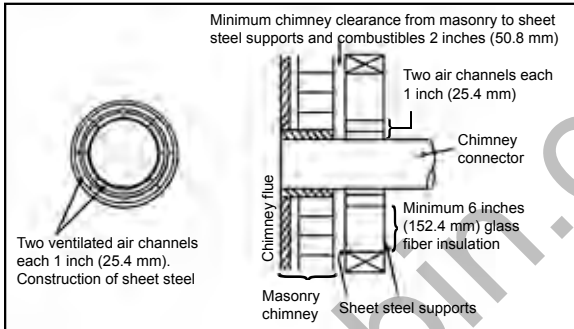

Figure 11: Chimney Through Wall - Method C.

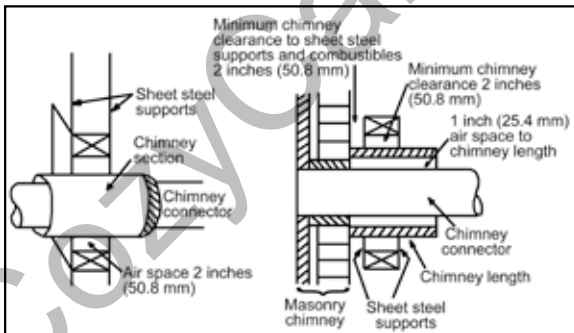

Figure 12: Chimney Through Wall - Method D.

Method A. 12" (304.8 mm) Clearance to Combustible Wall Member: Using a minimum thickness 3.5" (89 mm) brick and a 5/8" (15.9 mm) minimum wall thickness clay liner, construct a wall pass-through. The clay liner must conform to ASTM C315 (Standard Specification for Clay Fire Linings) or its equivalent. Keep a minimum of 12" (305 mm) of brick masonry between the clay liner and wall combustibles. The clay liner shall run from the brick masonry outer surface to the inner surface of the chimney flue liner but not past the inner surface. Firmly grout or cement the clay liner in place to the chimney flue liner.

Method B. 9" (229 mm) Clearance to Combustible Wall Member: Using a 6" (152 mm) inside diameter, factory-built Solid-Pak chimney section with insulation of 1" (25.4 mm) or more, build a wall pass-through with a minimum 9" (229 mm) air space between the outer wall of the chimney length and wall combustibles. Use sheet metal supports, fastened securely to wall surfaces on all sides, to maintain the 9" (229 mm) air space. When fastening supports to chimney length, do not penetrate the chimney liner (the inside wall of the Solid-Pak chimney). The inner end of the Solid-Pak chimney section shall be flush with the inside of the masonry chimney flue and sealed with a non-water soluble refractory cement. Use this cement to also seal to the brick masonry penetration.

Method C. 6" (152.4 mm) Clearance to Combustible Wall Member: Starting with a minimum 24 gauge (.024" [0.6 mm]) 6" (152.4 mm) metal chimney connector and a minimum 24 gauge ventilated wall thimble which has two air channels of 1" (25.4 mm) each, construct a wall pass-through. There shall be a minimum 6" (152.4 mm) separation area containing fiberglass insulation, from the outer surface of the wall thimble to wall combustibles. Support the wall thimble and cover its opening with a 24 gauge minimum sheet metal support. Maintain the 6" (152.4 mm) space. There should also be a support sized to fit and hold the metal chimney connector. See that the supports are fastened securely to wall surfaces on all sides. Make sure fasteners used to secure the metal chimney connector do not penetrate chimney flue liner.

Method D. 2" (50.8 mm) Clearance to Combustible Wall Member: Start with a solid-pak listed factory-built chimney section at least 12" (304 mm) long, with insulation of 1" (25.4 mm) or more, and an inside diameter of 8" (2" [51 mm] larger than the 6" [152.4 mm] chimney connector). Use this as a pass-through for a minimum 24 gauge single-wall steel chimney connector. Keep solid-pak section concentric with and spaced 1" (25.4 mm) off the chimney connector by way of sheet metal support plates at both ends of chimney section. Cover opening, and support chimney section on both sides, with 24 gauge minimum sheet metal supports. See that the supports are fastened securely to wall surfaces on all sides. Make sure fasteners are used to secure chimney flue liner.

NOTES:

1. Connectors to a masonry chimney, excepting method B, shall extend in one continuous section through the wall pass-through system and the chimney wall, to but not past the inner flue liner face.
2. A chimney connector shall not pass through an attic or roof space, closet or similar concealed space, or a floor, or ceiling.

INSTALLATION

INSTALLATION OF A LISTED, FACTORY BUILT CHIMNEY:

This is a generic set of instructions; always follow the chimney manufacturer's instructions explicitly. Also refer to "RECOMMENDED HEIGHTS FOR FLUE PIPE".

1. Set non combustible floor protector and stove in location in accordance with the "CLEARANCES TO COMBUSTIBLES".
2. Mark the position for the ceiling hole by suspending a plumb bob from the ceiling over the exact center of your stove flue and mark a spot on the ceiling to indicate the center of the chimney.
3. Move this location, if necessary, to avoid floor joists, ceiling rafters, electrical wiring and plumbing while still maintaining required clearances. If floor joists or ceiling rafters must be cut they must be made structurally sound again. Install chimney according to chimney manufacturers instructions. A chimney connector cannot pass through an attic or roof space, closet or similar concealed space, or a floor, ceiling, wall or partition of combustible construction. In Canada, if passage through a wall or partition of combustible construction is desired, the installation shall conform to CAN/CSA-B365 Installation Code for Solid-Fuel Burning Appliances and Equipment and NFPA 211 Standard for Chimneys, Fireplaces, Vents, and Solid Fuel-Burning Appliances.

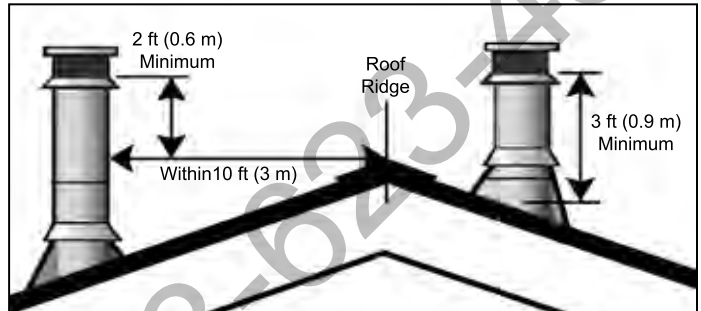

Figure 13: Roof Clearances.

4. Mark the hole for the outside air kit.
5. Move the stove out of the way.
6. Cut a pilot hole in the ceiling.
7. Cut a hole for the ceiling penetration components and frame in the sides of the hole in both the ceiling and roof. Check, and follow chimney manufacturer's instructions for all of these steps.
8. Install the support box and chimney through the roof. Install the slip section for the chimney connector.
9. Slip the roof flashing over the chimney and secure to the roof, being careful to keep the pipe centered in the opening. To meet the code, the chimney must extend above the roof penetration at least 3 feet (91.4 cm), and in any area within 10 feet (304.8 cm) of the

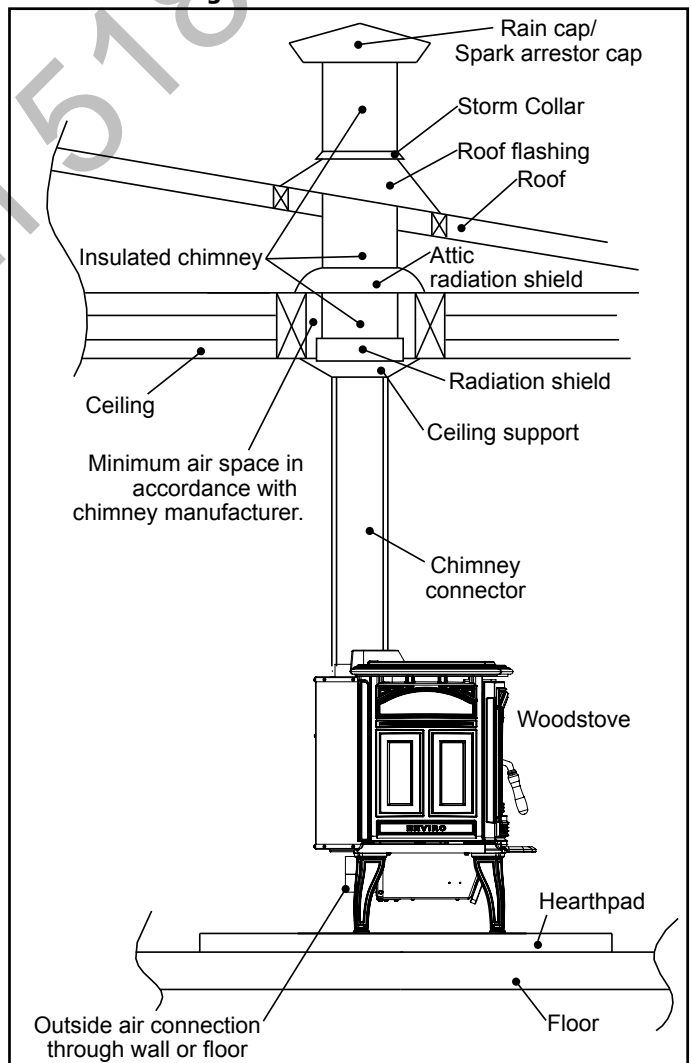

Figure 14: Standard Vertical Installation.

INSTALLATION

roof ridge, the chimney must be 2 feet (60.9 cm) above the ridge. Refer to Figure 13.

Note: Increasing the chimney height above the roof may help your unit to draft better. This greater draft can decrease problems such as difficult start-ups, smoke coming out when door is open, and dirty glass. You may initially try the minimum required height and if problems do arise, add additional height later.

10. Slide the roof flashing over your chimney and seal the flashing to the roof with a roofing compound. Secure the roof flashing to your roof with nails or screws.
11. Place the storm collar over the flashing and seal the joints with silicone caulking.
12. Fasten the rain cap / spark arrestor cap to the top of your chimney.
13. Place the stove back into position.

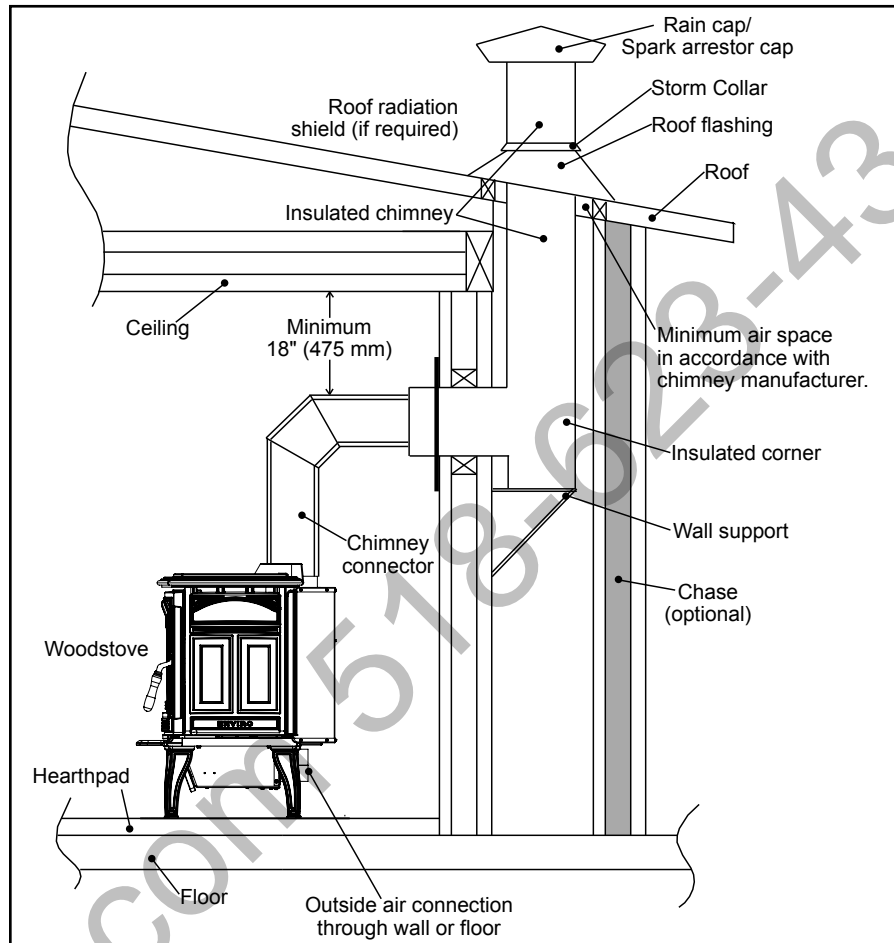

Figure 15: Standard Horizontal Installation.

14. Install the chimney connector pipe with the lower (crimped) edge of the pipe inside the flue collar. Any creosote formed will then run back down into the stove. All connections must be tight and secured with three sheet metal screws equally spaced. Double wall pipe is recommended over single wall.
15. Also install an outside air flex pipe to the stove.

IMPORTANT: When a metal prefabricated chimney is used, the manufacturer's installation instructions must be followed. You must also purchase and install the ceiling support package or wall pass-through and "T" section package, firestops (where needed), insulation shield, roof flashing, chimney cap, etc. Maintain proper clearance to the structure as recommended by the manufacturer. The chimney must be the required height above the roof or other obstructions for safety and proper draft operation.

Note: If you are using a horizontal connector (refer to Figure 15), the chimney connector should be as high as possible while still maintaining the 18" (475 mm) minimum distance from the horizontal connector to the ceiling.

INSTALLATION

MASONRY CHIMNEY INSTALLATION:

DO NOT CONNECT THIS UNIT TO A CHIMNEY FLUE SERVING ANOTHER APPLIANCE.

A non-combustible floor protector is required under all freestanding units; refer to "CLEARANCES TO COMBUSTIBLES". When venting into a masonry chimney, the floor protector must be installed directly below the chimney vent and 2" (50.8 mm) on either side of the chimney vent.

Vent the stove into a clean, lined, approved masonry chimney in good condition, conforming to local building codes and meeting the minimum standards of the National Fire Protection Association (NFPA). Make sure there are no cracks, loose mortar or other signs of deterioration and blockage. Have the chimney cleaned before the stove is installed and operated, or vent with a listed 6" (150 mm) factory-built chimney suitable for use with solid fuels and conforming to ULC-S629 Standard for 650°C factory-Built Chimneys in CANADA or UL 103 HT Factory-Built Chimneys for Residential Type and Building Heating Appliances in the U.S.A. Connect the stove to this chimney with a short and straight 6" (150 mm), 24 gauge or heavier, single-wall black or blued steel smoke pipe. Connection to all masonry chimneys must be a metal or masonry thimble cemented in place. All smoke pipes must slope upwards, all connections must be tight and secured with three sheet metal screws equally spaced. The smoke pipe length should not exceed 40% of the chimney height above the stove.

When connecting the stove through a combustible wall to a masonry chimney, additional steps are required. Consult the chimney connector manufacturer and refer to Figure 17.

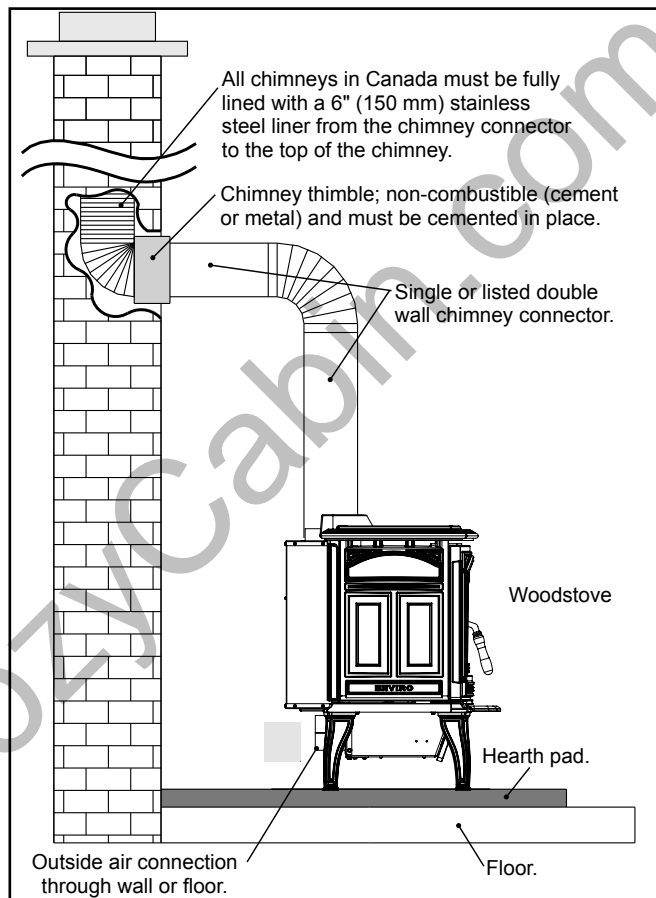

Figure 16: Installation into a masonry chimney.

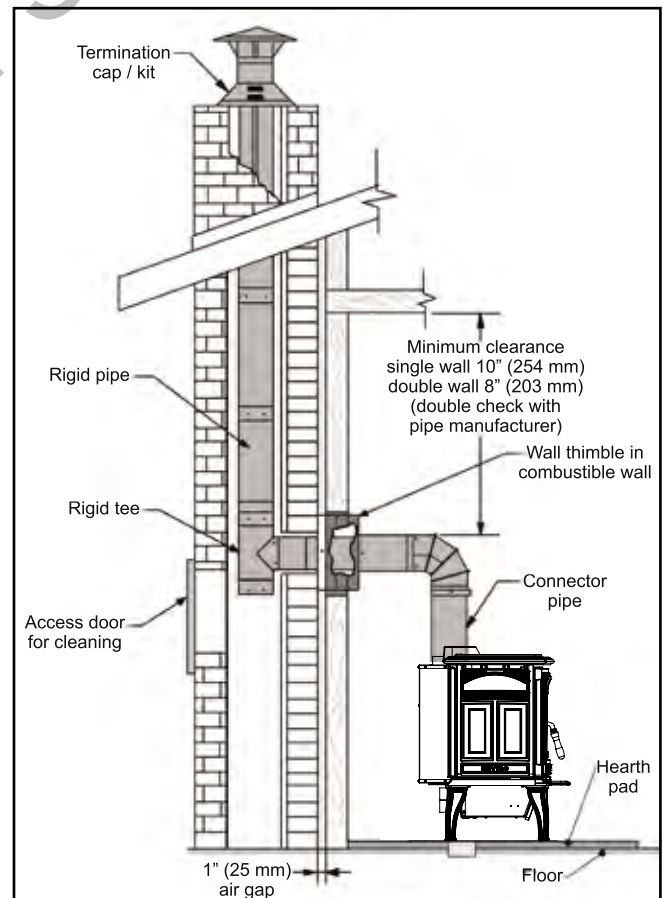

Figure 17: Installation into chimney through a combustible wall.

INSTALLATION

MASONRY FIREPLACE INSTALLATION - FREESTANDING:

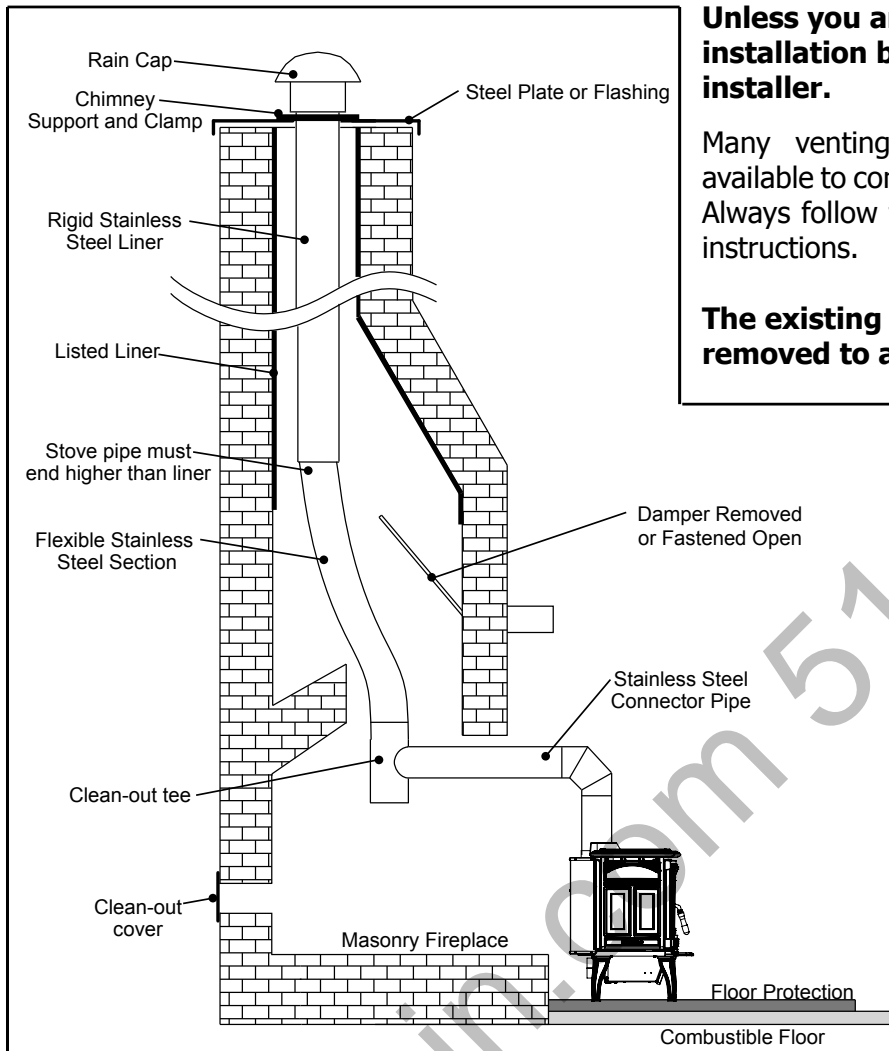

Figure 18: Freestanding Installation into existing fireplace.

Unless you are experienced, we recommend installation by your dealer or a professional installer.

Many venting manufacturers have listed kits available to connect a stove to a masonry fireplace. Always follow the vent manufacturer's installation instructions.

The existing damper may have to be removed to allow installation.

MOBILE HOME INSTALLATION:

SPECIAL REQUIREMENTS: All freestanding installation requirements in "Installation Of A Listed, Factory Built Chimney", must comply with all local codes that may apply, and the following must be met:

VENTING:

In Canada: Any ULC-S629 listed chimney system with the accompanying double-wall vent connector.

In U.S.A. Any UL-103-HT listed chimney system with the accompanying double-wall vent connector. Do not connect a listed chimney of one manufacturer with a listed double wall connector from another manufacturer.

These connectors must be installed in accordance with the manufacturer's instructions. Use only specified components. The chimney and pipe must extend at least 10 feet (2.4 m) above the stove and 3 feet (0.9 m) above the highest point of the roof. Install a rain cap with spark arrestor at the top that will not impede the smoke exhaust. The chimney must be supported at the ceiling or roof so that its weight will not sit on the stove. Seal with silicone to maintain vapor barrier at the chimney and outside air penetrations.

INSTALLATION

Chimney must be removable to allow for transportation of the mobile home.

CAUTION: THE STRUCTURAL INTEGRITY OF THE MOBILE HOME FLOOR, WALL, AND CEILING/ROOF MUST BE MAINTAINED.

OUTSIDE AIR :

Connection from the stoves air intake to the outside is **mandatory**, (MOBILE HOMES ONLY) either through a hole in the wall not higher than the stoves bottom or through a hole in the floor, using the fresh air adaptor. Avoid cutting any floor joists, wall studs, electrical wiring or plumbing. Seal around the outside air pipe with insulation to prevent drafts. Also install a ¼" mesh rodent or pest screen in the end of fresh-air pipe. Fresh-air connection must be of a non-combustible material, example: 4" (10.16 cm) flexible aluminum single wall pipe.

Fresh air could also be supplied from a **vented crawlspace**.

The legs must be firmly bolted to the floor using four ¼" bolts. Be sure to replace any insulation or panels removed when fastening the bottom nuts.

If room air starvation occurs because the air intake is blocked with ice, leaves etc., or because the stove door was left open, or due to a strong exhaust fan operating, dangerous fumes could be sucked into the room.

IN SOME AREAS IT MAY BE REQUIRED TO ELECTRICALLY GROUND THE STOVE TO THE STEEL CHASSIS OF THE MOBILE HOME.

When this unit is installed in a Mobile Home it must be grounded to the steel chassis or connected to a grounding rod.

Manufactured (Mobile) home installation must be in accordance with the Manufactured Home Construction and Safety Standard, UL 307B, Title 24 CFR, Part 3280 and/or The Standard for Manufactured Home Installations, ANSI A225.1/NFPA 501A.

WARNING: DO NOT INSTALL IN SLEEPING ROOM.

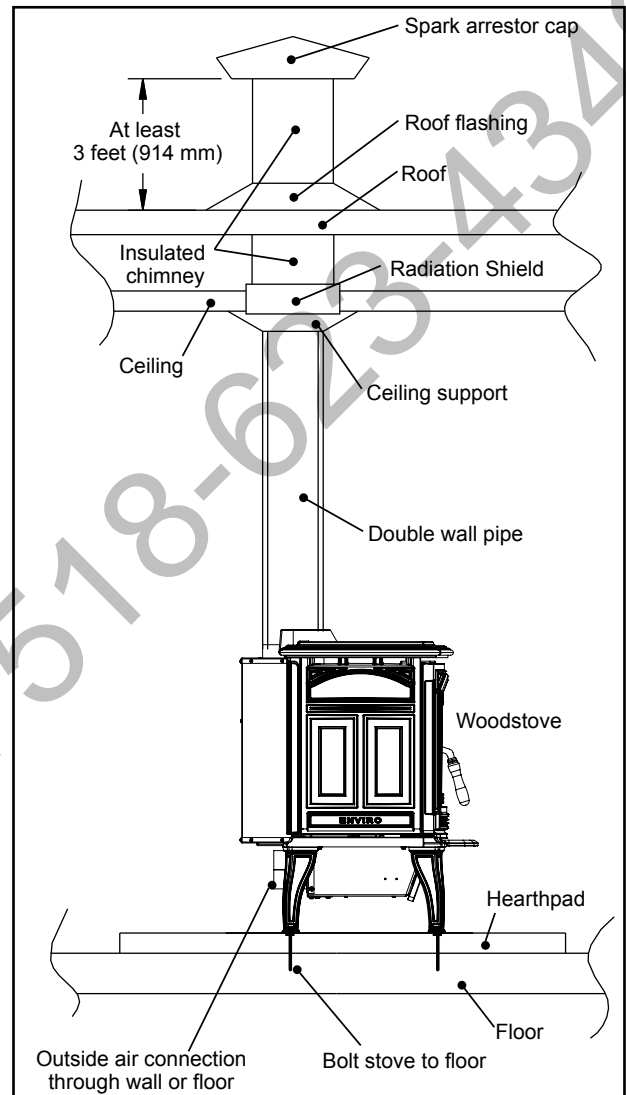

Figure 19: Freestanding installation into mobile home.

INSTALLATION

MODEL 1200 BRICK PLACEMENT & TUBE LOCATIONS:

COMPLETE THE STOVE AND SMOKE PIPE INSTALLATION BEFORE PLACING THESE BRICKS.

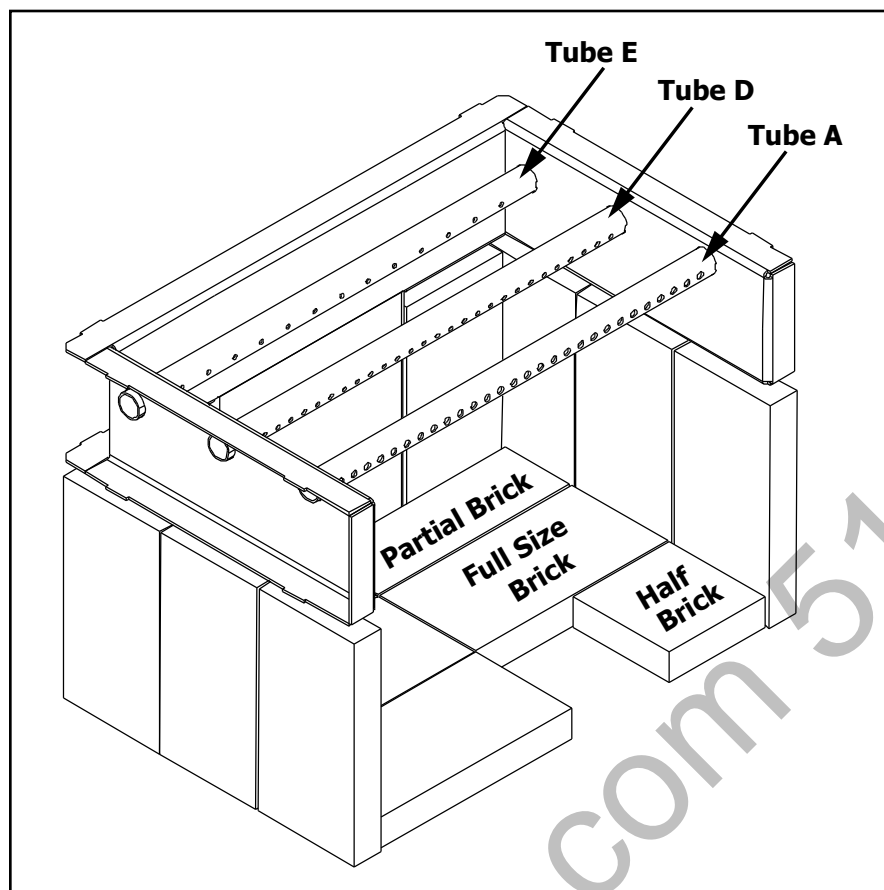

Figure 20: Brick Placement for 1200 shown with Secondary Air Channel and Tubes.

When replacing bricks, use only pumas type fire bricks.

TOTAL BRICKS:

- | | |
|-----------------------|--|
| 11 - Full size bricks | 9" long x 4.5" wide x 1.25" thick
(22.9 cm long x 11.4 cm wide x 3.2 cm thick) |
| 2 - Partial bricks | 9" long x 3" wide x 1.25" thick
(22.9 cm long x 7.6 cm wide 3.2 cm thick) |
| 1 - Half brick | 4.5 " long x 4.5" wide x 1.25" thick
(11.43 cm long x 11.43 cm wide x 3.175 cm thick) |

Removing Air Tube: If a secondary air tube needs to be removed, place a screwdriver (any style except flat head) into one of the air holes and tap it with a hammer/mallet to the left until the right end of the tube is freed. To install a secondary air tube, reverse the above instructions.

IMPORTANT: All secondary air tubes must be in place for proper operation.

INSTALLATION

MODEL 1700 BRICK PLACEMENT & TUBE LOCATIONS:

COMPLETE THE STOVE AND SMOKE PIPE INSTALLATION BEFORE PLACING THESE BRICKS.

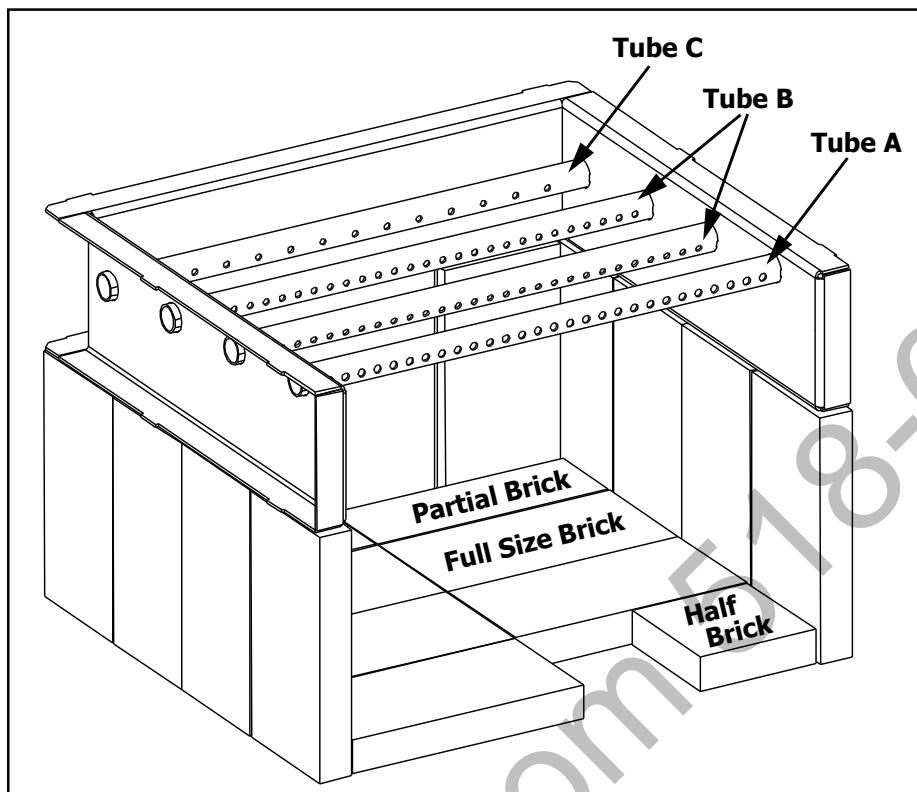

Figure 49: Brick Placement for 1700 shown with Secondary Air Channel and Tubes.

1. Place the four (4) full size bricks along each side of the firebox and one (1) full size brick on either side of the back of the firebox.
2. To place the floor bricks, lay the two (2) partial bricks along the back of the floor. Then on the left, lay three (3) full size bricks and on the right, lay two (2) full size bricks in the center and the half brick in the front (for the ash dump). The spaces between the bricks will soon fill with ashes.

When replacing bricks, use only pumas type fire bricks.

TOTAL BRICKS:

- | | |
|-----------------------|--|
| 15 - Full size bricks | 9" long x 4.5" wide x 1.25" thick
(22.9 cm long x 11.4 cm wide x 3.2 cm thick) |
| 2 - Partial bricks | 9" long x 3" wide x 1.25" thick
(22.9 cm long x 7.6 cm wide 3.2 cm thick) |
| 1 - Half brick | 4.5 " long x 4.5" wide x 1.25" thick
(11.43 cm long x 11.43 cm wide x 3.175 cm thick) |

Removing Air Tube: If a secondary air tube needs to be removed, place a screwdriver (any style except flat head) into one of the air holes and tap it with a hammer/mallet to the left until the right end of the tube is freed. To installation a secondary air tube reverse the above instructions.

IMPORTANT: All secondary air tubes must be in place for proper operation.

INSTALLATION

C-CAST CERAMIC BAFFLE INSTALLATION:

1. Slide the right C-Cast Ceramic Baffle in over the secondary air tubes at the top of the firebox. The tab must be on the top and pointing towards the center and the smooth side is to face down.
2. Hook the outside edge of the baffle over the top of the secondary air chamber. This will make room to for the installation of the left C-Cast Ceramic Baffle.
3. Slide the left C-Cast Ceramic Baffle in over the secondary air tubes. The tab must be on the bottom and pointing towards the center and the smooth side is to face down.
4. Pull the baffles together in the middle so the right tab rests on top of the left tab. Ensure the baffles are flush with the back and both sides of the firebox.

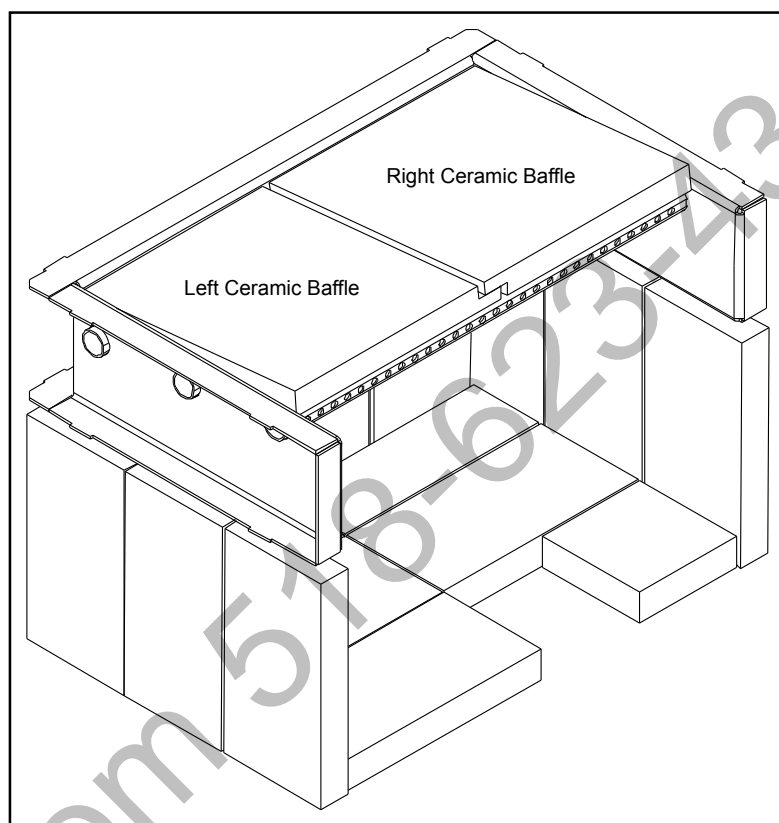

Figure 21: Installation of C-Cast Ceramic Baffle.

FAN WIRING DIAGRAMS:

This appliance, when installed, must be electrically connected and grounded in accordance with local codes or in the absence of local codes, with the current CSA C22.1 CANADIAN ELECTRICAL CODE. Part 1, SAFETY STANDARDS FOR ELECTRICAL INSTALLATIONS, or THE NATIONAL ELECTRICAL CODE ANSI / NFPA 70 in the USA.

CAUTION Label all wires prior to disconnection when servicing controls. Wiring errors can cause improper and dangerous operation. Verify proper operation after servicing.

DO NOT oil the fan bearings.

DO NOT cut or remove the grounding prong from the plug.

DO NOT route the power cord beneath the heater.

WARNING: This appliance is equipped with a three-prong (grounding) plug for your protection against shock hazard and should be plugged into a properly grounded three-prong receptacle.

INSTALLATION

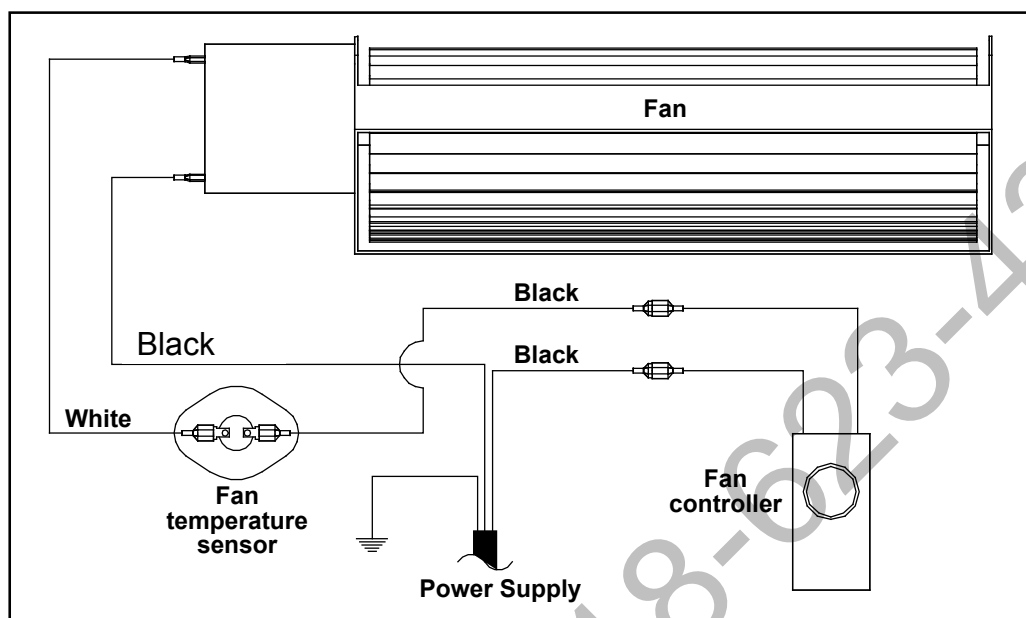

Figure 22: Freestanding Fan Kit Wiring Diagram.

OPTIONAL FAN INSTALLATION - FREESTANDING:

Refer to FAN WIRING DIAGRAM before installing your optional fan kit.

1. Remove the fan assembly from the box and inspect for any damage to the assembly. If damage is noticed call your dealer, distributor or courier company and have components replaced before installing kit.
2. Install the four #10 screws loosely into the bottom of the air cabinet.
3. Align the keyslots of the fan assembly with four screws. Fully bottom the keyslots before tightening the screws
4. Plug the fan assembly in and check for proper operation.

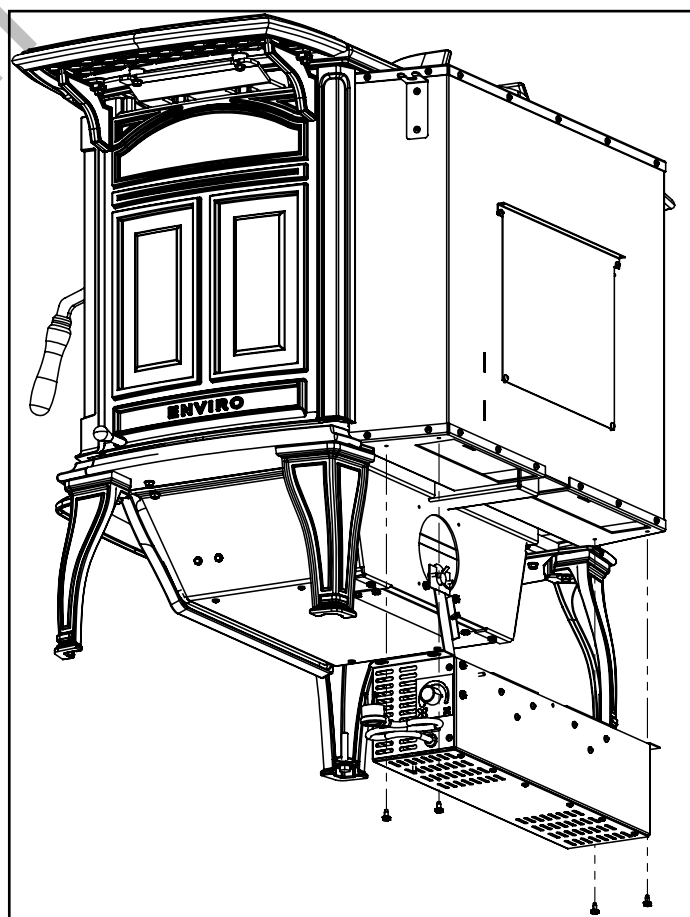

Figure 23: Back View of Freestanding Unit with Fan Kit.

DISASSEMBLY

REMOVAL OF CAST SIDES AND DOOR:

To remove the cast sides, lift off the Cast Top and then unscrew the slider knob and then remove the two top bolts using a 3/8" socket. The Cast Side may then be lifted up.

The door may be taken off by first lifting off the Cast Top and then removing the two bolts from the top door hinge, using a 3/8" socket.

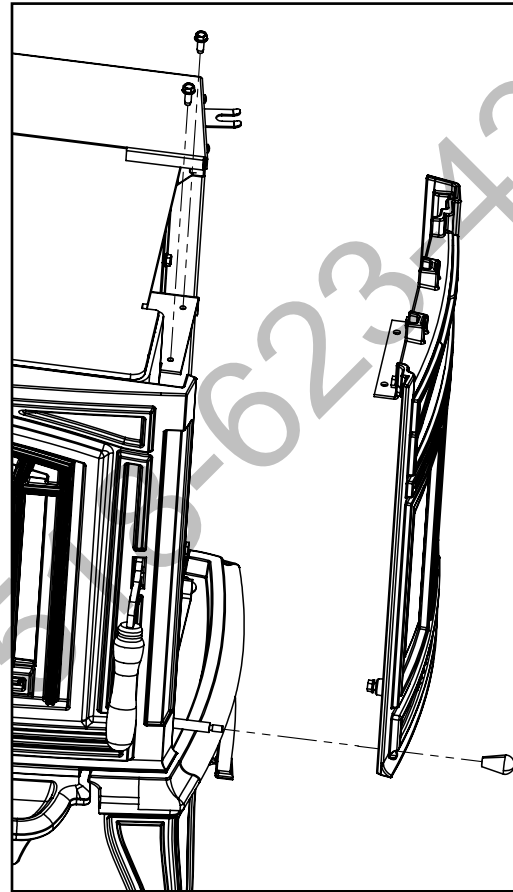
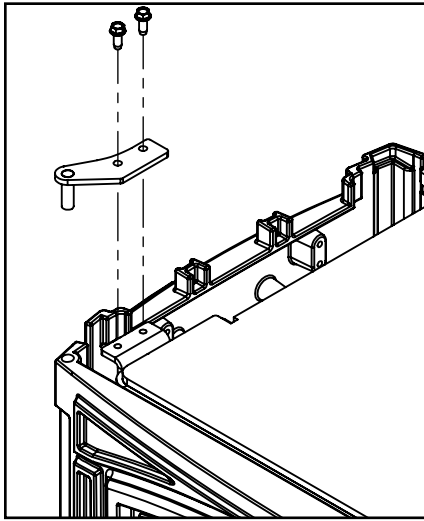

DOOR LATCH ADJUSTMENT:

Over time as the door gasket fully compresses to the face of the firebox, it may be necessary to adjust the door latch position to maintain a tight seal. Signs that the door latch may need adjusting are if the door handle feels overly loose when closed, or if you notice air leaks occurring during low burns.

1. Remove the right Cast Side (shown above)
2. Use a 3/8" socket to loosen the two 1/4" bolts and slide the latch slightly back. Retighten the bolts and latch the handle. The handle should provide a bit of resistance and close firmly.



RATING LABEL

Tested & Listed By **OTAUS** Portland Oregon USA
OMNI-Test Laboratories, Inc.
 Certified for use in Canada & USA /
 Certifié pour installation au Canada et aux États-Unis.

DO NOT REMOVE THIS LABEL / NE PAS ENLEVER CETTE ÉTIQUETTE
LISTED SOLID FUEL SPACE HEATER / IDENTIFIÉ COMME UN FOYER À COMBUSTIBLE SOLIDE

Serial No. / No. De Série:

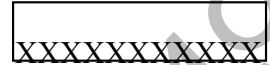

- Boston 1200 FS 268-S-04b-2
 Kodiak 1200 FS 268-S-04b-2
 Boston 1200 FPI 268-S-05b-2
 Venice 1200 FPI 268-S-05b-2
 Kodiak 1200 FPI 268-S-05b-2
 Boston 1700 FS 268-S-01b-2
 Kodiak 1700 FS 268-S-01b-2
 Boston 1700 FPI 268-S-06b-2
 Venice 1700 FPI 268-S-06b-2
 Kodiak 1700 FPI 268-S-06b-2

Models 1200 and 1700 Freestanding units: Room Heater, Solid Fuel Type, Also For Use In Mobile Homes. Tested to ULC-S627-00, ULC-S628-93 (FPI only), & UL-1482-10. US Environmental Protection Agency, certified to comply July 1, 1990, particulate emission standards. Certified to CAN/CSA-B415.1-M92 and EPA 40 CFR Part 60 wood burning appliance standard. Install and use only in accordance with the manufacturers installation and operating instructions. Contact local building or fire officials about restrictions and installation inspection in your area. Use 6" (150 mm) diameter minimum 24 MSG black or 25 MSG blue steel connector listed factory-built chimney suitable for use with solid fuels or masonry chimney. See local building code and manufacturer's instructions for precautions required for passing a chimney through a combustible wall or ceiling. Do not pass chimney connector through a combustible wall or ceiling. Minimum clearances from horizontal connector and ceiling 18" (455 mm). Do not connect this unit to a chimney flue servicing another appliance.

Modèles 1200 et 1700 items indépendants: Chauffage pièce, le type de combustible solide, également pour une utilisation dans les maisons mobiles. Testé selon ULC-S627-00, ULC-S628-93 (FPI seulement), & UL-1482-10. États-Unis Environmental Protection Agency, a certifié pour conformer au Juillet 1, 1990, les normes de particules d'émission. Certifié CAN/CSA-B415.1-M92 et EPA 40 CFR Part 60 standard de l'appareil de chauffage au bois. Ce dispositif doit être installé et opéré conformément aux instructions d'installation et d'opération du fabricant contactez le service local de l'inspection des bâtiments ou l'officier pompier concernant les restrictions et l'inspection d'installation dans votre localité. Utilisez des connecteurs répertoriés 24 MSG noir ou 25 MSG en acier broncée de 6" (150 mm) minimum, et une cheminée de fabrication industrielle, appropriée pour utilisation avec des combustibles solides où avec une cheminée de maçonnerie. Vérifiez les précautions à prendre exigées par code local et les instructions du fabricant concernant les conditions pour passer la cheminée à travers un mur ou un plafond combustible. Net pas installer le connecteur de la cheminée à travers un mur ou un plafond combustible. Espaces libres minimum d'un connecteur horizontal et plafond sont 18" (455 mm) ne pas connecter ce dispositif à un conduit de cheminée qui sert déjà un autre dispositif.

	Minimum Clearances to Combustible Materials / Espaces Libres Aux Matériaux Combustibles.	Single wall pipe / Seul connecteur de mur		**Double wall pipe / Double connecteur de mur		Double wall pipe with efficiency shield (Flat top model only) / Double connecteur de mur avec la protection d'efficacité (Le modèle plat seulement)		Top vent out back wall with min. 24" (610mm) vertical rise; double wall pipe / Donné vent hors de la paroi arrière avec le min. 24" (610 mm) l'ascension verticale; double connecteur de mur	
		1200	1700	1200	1700	1200	1700	1200	1700
A	Sidewall to unit / De la paroi latérale au dispositif	13" (330 mm)	20" (508 mm)	13" (330 mm)	13" (330 mm)	13" (330 mm)	13" (330 mm)	14" (356 mm)	11" (279 mm)
B	Backwall to unit / De la paroi arrière au dispositif	11" (279 mm)	12" (305 mm)	10" (254 mm)	10" (254 mm)	8" (203 mm)	7" (178 mm)	12" (305 mm)	13" (330 mm)
C	Adjacent wall to corner of unit / De la paroi adjacente au coin de dispositif	9" (229 mm)	10" (254 mm)	8" (203 mm)	8 1/2" (216 mm)	6 1/2" (165 mm)	6" (152 mm)		
D	Sidewall to connector / De la paroi latérale au connecteur	22" (559 mm)	25" (737 mm)	22" (559 mm)	22" (559 mm)	22" (559 mm)	22" (559 mm)	23" (584 mm)	16" (381 mm)
E	Backwall to connector / De la paroi arrière au connecteur	14" (356 mm)	15" (381 mm)	13" (330 mm)	13" (330 mm)	11" (279 mm)	10" (254 mm)	15" (381 mm)	15" (406 mm)
F	Adjacent wall to connector / De la paroi adjacente au connecteur	17 1/2" (445 mm)	18 1/2" (470 mm)	16 1/2" (419 mm)	17" (432 mm)	15" (381 mm)	14 1/2" (368 mm)		
G	† Front of door opening to edge of hearth / Le devant d'ouverture de porte au bord de coussin de cœur	USA 16" (406 mm) CND 18" (450 mm)							
H	† Side/back of unit to edge of hearth / Le latérale/arrière de dispositif au bord de coussin de cœur	USA 6" (152 mm) CND 8" (200 mm)							

CAUTION: An uninsulated smoke pipe must not pass through an attic, roof space, closet or similar concealed space, or through a floor, ceiling, wall, or partition, or any combustible construction.
 † FLOOR PROTECTION: If a stove is installed on a combustible floor, it must have the legs or pedestal attached and be on a NON COMBUSTIBLE hearth pad
 * ALL CLEARANCES CAN BE REDUCED WITH SHIELDING ACCEPTABLE TO THE LOCAL AUTHORITY.
SINGLE WALL:
 IN CANADA: Any ULC-S629 listed chimney system with the accompanying listed single wall vent connector.
 IN U.S.A.: Any UL 103 HT listed chimney system with the accompanying listed single wall vent connector.
****DOUBLE WALL:**
 IN CANADA: Any ULC-S629 listed chimney system with the accompanying listed double wall vent connector.
 IN U.S.A.: Any UL 103 HT listed chimney system with the accompanying listed double wall vent connector.
DOUBLEWALL IS REQUIRED FOR MOBILE HOME INSTALLATIONS.

MISE EN GARDE: Un uninsulated tuyau de fumée ne doit pas passer par un grenier, un espace de toit, le placard ou l'espace dissimulé similaire, ou par un plancher, un plafond, un mur, ou une cloison, ou une construction combustible.
 † PROTÉGER LE PLANCHER: Si une cuisinière est installée sur un sol combustible, il doit avoir un piédestal attache et être sur un coussinet non-combustible.
 TOUS "ESPACES LIBRES AUX MATÉRIEL COMBUSTIBLES" PEUVENT ÊTRE RÉDUITS AVEC PROTÉGÉANT ACCEPTABLE À L'AUTORITÉ LOCALE.
Seul Connecteur de Mur:
 Au Canada: Certifiée seul connecteur de mur avec toute systèmes de cheminée listée sous ULC-S629.
 Aux États-Unis: Certifiée seul connecteur de mur avec toute systèmes de cheminée listée sous UL 103 HT.
****Double Connecteur de Mur:**
 Au Canada: Certifiée double connecteur de mur avec toute systèmes de cheminée listée sous ULC-S629.
 Aux États-Unis: Certifiée double connecteur de mur avec toute systèmes de cheminée listée sous UL 103 HT.

**Double Wall (Use double wall pipe) / Alcôve (Utilisant le double connecteur de mur)	Model/Modèle 1200	Model/Modèle 1700
I Total width / Largeur totale	55" (1397 mm)	51" (1295 mm)
J Total height / Hauteur totale	78" (1981 mm)	72" (1829 mm)
K Top of stove to ceiling / Le sommet de poêle au plafond	49" (1245 mm)	44" (1118 mm)
L Sidewall to unit / De la paroi latérale au dispositif	15" (381 mm)	13" (330 mm)
M Sidewall to connector / De la paroi latérale au connecteur	24" (610 mm)	22" (559 mm)
N Backwall to unit / De la paroi arrière au dispositif	12" (305 mm)	8" (203 mm)
O Backwall to connector / De la paroi arrière au connecteur	15" (381 mm)	11" (279 mm)
P Maximum Depth / Profondeur maximum	48" (1220 mm)	48" (1220 mm)

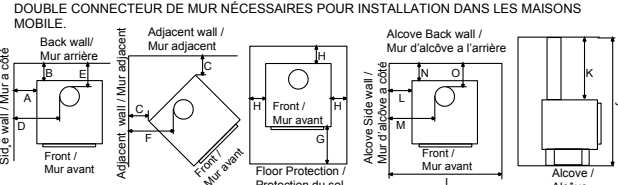

Models 1200 and 1700 inserts may be installed as an insert in a masonry fireplace. / On peut encastrier le modèles 1200 et 1700 dans un foyer de maçonnerie.

Model / Modèle	1200 FPI	1700 FPI
A To unshielded side wall / aux mur non protégé	10" (254 mm)	10" (254 mm)
B To an unshielded 8" (203 mm) mantle / aux manteau 8" non protégé	21" (533 mm)	24" (610 mm)
C To top facing (protruding 3/2" [19 mm] clearance / aux revêtement supérieur	17 1/2" (445 mm)	19 1/2" (495 mm)
D To side facing (protruding 3/2" [19 mm] clearance / aux revêtement a côté	1" (25 mm)	1" (25 mm)
E † From door opening of unit to edge of floor protection / De ouverture de la porte de l'unité à bord de la protection de plancher	USA 16" (406mm) / CND 18" (450mm)	
F † From side of unit to edge of floor protection / Du côté de l'unité au bord de la protection de plancher	USA 6" (152 mm) / CND 8" (200 mm)	

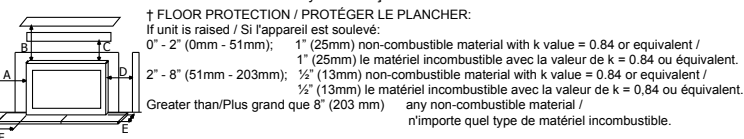

OPERATE ONLY WITH DOORS CLOSED. Only open door to feed fire. For use with solid wood fuels only. Do not use any other type of fuel. Do not use grate or elevate-fire build wood fire directly on hearth. Do not overfire. Do not obstruct beneath the heater. If heater or chimney connector glows, you are overfiring. Inspect and clean chimney frequently-under certain conditions of use, creosote buildup may occur rapidly. The provided insulation materials are required for operation. Keep furnishing and other combustibles well away from heater. Replace glass only with 5mm thick ceramic glass. Optional component for FS: fan, electrical rating 115V, 60 Hz 1 Amp (Part # EFVW-261). Combustion air openings are not to be obstructed.
Danger: Risk of electrical shock. Disconnect power before servicing unit. Route cord away from heater.

L'OPERATION DU POELE DOIT SE FAIRE AVEC LA PORTE FERME. N'ouvrir la porte que pour alimenter le feu. N'utilisez que des combustibles solides. Ne pas utiliser un autre type de carburant. N'employez pas de grille de foyer ou ne surélevez pas le feu. Mettez le bois à brûler directement sur l'âtre. Pour éviter la surchauffeur, ne mettez pas trop de bois. N'obstruez pas les ouvertures d'air carburant. Si le poêle ou le connecteur commencent à luire, vous surchauffez le poêle. Inspectez et nettoyez la cheminée souvent. Dans certaines conditions, le créosote peut s'accumuler rapidement. Les matériaux d'isolation fournis sont requis pour l'opération. Tenez loin les meubles et d'autres produits combustibles. Ne remplacez le verre qu'avec du verre céramique, 5mm épais. Équipement en option pour un FS: ventilateur caractéristiques assignées 115V, 60 Hz, 1 Amp (pièce # EFVW-261) tenez le câble électrique loin du poêle. **Danger:** Le risque de choc électrique. Débrancher le dispositif avant d'entretenir. Ouvertures d'air de combustion ne doivent pas être obstrués.

CAUTION: HOT WHILE IN OPERATION. DO NOT TOUCH. KEEP CHILDREN, CLOTHING AND FURNITURE AWAY. CONTACT MAY CAUSE SKIN BURN. READ NAMEPLATE AND INSTRUCTIONS.



MISE EN GARDE: TRÈS CHAUD QUAND ALLUMÉ. NE TOUCHEZ PAS. TENIR LOIS LES ENFANTS, LES VÊTEMENTS ET LES MEUBLES. LE CONTACT PEUT CAUSER DES BRÛLURES. LISEZ ATTENTIVEMENT L'ÉTIQUETTE ET LES INSTRUCTIONS.

MADE IN CANADA / FABRIQUE AU CANADA MANUFACTURED BY / FABRIQUE PAR: SHERWOOD INDUSTRIES LTD. 6782 OLDFIELD ROAD, SAANICHTON, BC CANADA

DATE OF MANUFACTURE / DATE DE FABRICATION:

J	F	M	A	M	J	J	A	S	O	N	D	2011	2012	2013	2014	2015
---	---	---	---	---	---	---	---	---	---	---	---	------	------	------	------	------

C-13751



PARTS LIST

Reference #	Description	Part #
1	120°F (49°C) Ceramic Fan Temperature Sensor	EC-001
2	Convection Blower	50-2493
3	FPI Fan Controller - 115V	EC-039
3	Fan Controller Knob	EC-040
4	Domestic power cord - 115V	EC-042
5	Boston 1200 FS Fan Kit	50-2417
-	Boston 1700 FS Fan Kit	50-2572
6	Fresh Air Kit (for fan)	50-2440
7	Fresh Air Kit	EF-186
8	1200 Boston FS Cast Top	50-2441
9	1700 Boston FS Cast Top	50-2582
10	Boston Cast Side Right	50-2443
11	Cast Leg Lip Right	50-2114
12	Boston FS Cast Side Left	50-2442
13	Side Shelves (Set of 2)	50-1991
14	Cast Leg Lip Left	50-2113
15	Cast Leg	50-2106
16	Boston Ash Pan	50-2446
17	Boston Cast Ash Drawer Cover	50-2444
18	1200 C-Cast Ceramic Baffle (1 Piece)	50-1146
19	1200 Secondary Air Tube Rear E	50-1102
20	1200 Secondary Air Tube Middle D	50-1103
21	1200 & 1700 Front Secondary Air Tube A	50-1099
22	1700 Middle Secondary Tube B	50-1101
23	1700 Rear Secondary Tube C	50-1100
24	1700 C-Cast Ceramic Baffle (1 Piece)	50-1147
25	Pumice Brick 4.5" x 9"	50-1105
26	Pumice Brick 3" x 9"	50-1104
27	Pumice Bricks - 4½" X 4½"	50-1106
28	1200 & 1700 Right Shield Assembly	50-1145
29	1200 & 1700 Left Shield Assembly	50-1144
30	1200 & 1700 Cast Ash Plug	50-1120
31	Door Gasket - 7 feet (2.13m)	EF-168
32	Wood Door Glass Retainer Kit (With Screws)	50-1122
33	Glass with Tape	10-000
34	Boston Cast Front	50-2445
35	Boston Door Handle Complete	50-2393
36	Woodstove Poker	50-1816
-	Owner's Manual	50-2439
-	Gloves	50-1525

PARTS DIAGRAM - FREESTANDING

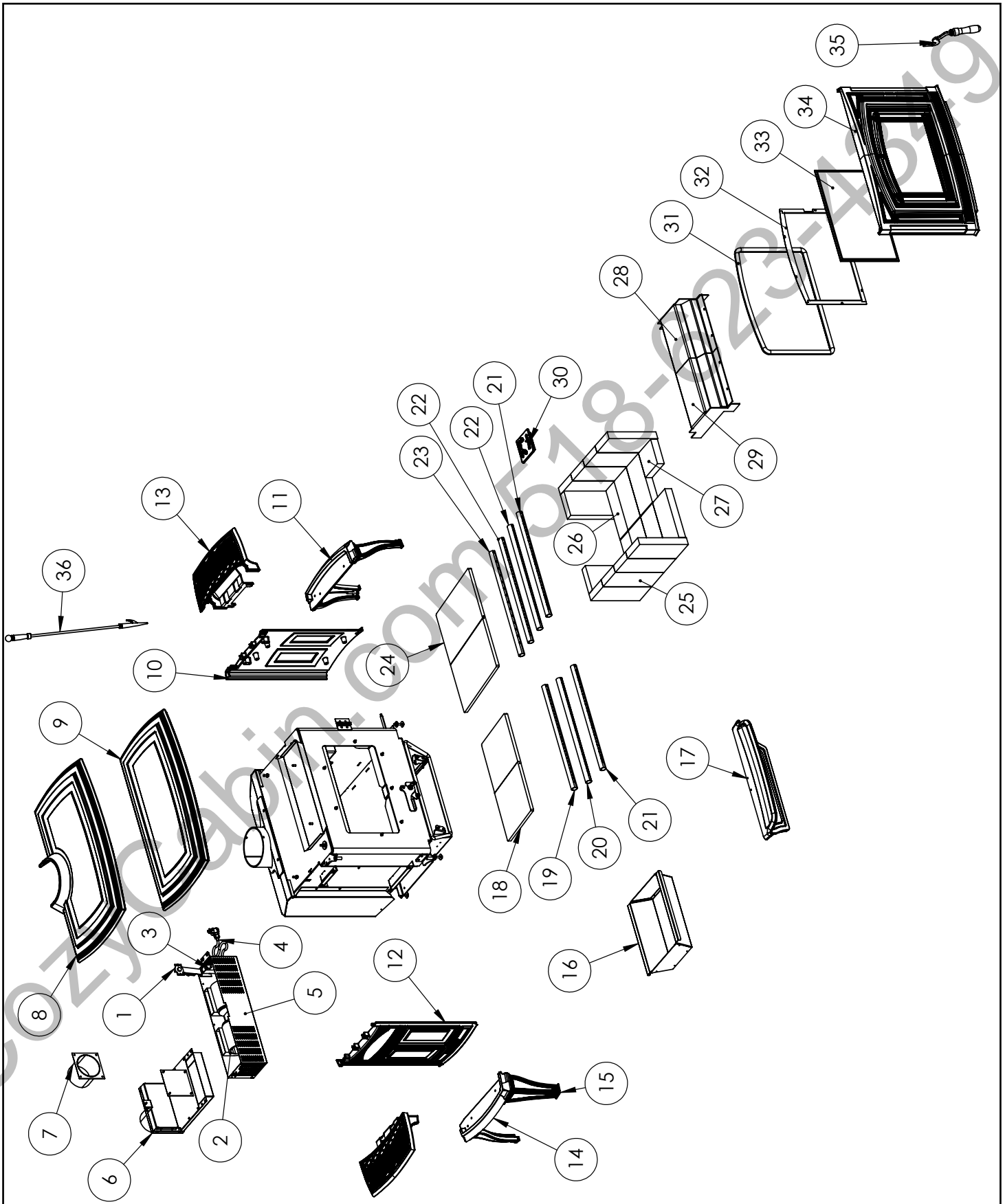



Warranty for Enviro Wood Products

Sherwood Industries Ltd. ("Sherwood") hereby warrants, subject to the terms and conditions herein set forth, this product against defects in material and workmanship during the specified warranty period starting from the date of original purchase at retail. In the event of a defect of material or workmanship during the specified warranty period, Sherwood reserves the right to make repairs or to assess the replacement of a defective product at Sherwood's factory. The shipping costs are to be paid by the consumer. All warranties by Sherwood are set forth herein and no claim shall be made against Sherwood on any oral warranty or representation.

Conditions

- A completed warranty registration must be submitted to Sherwood within 90 days of original purchase via the online warranty registration page or via the mail-in warranty registration card provided. Have the installer fill in the installation data sheet in the back of the manual for warranty and future reference.
- This warranty applies only to the original owner in the original location.
- The unit must have been properly installed by a qualified technician or installer, and must meet all local and national building code requirements.
- The warranty does not cover removal and re-installation costs.
- Sherwood Industries Ltd. reserves the right to make changes without notice.
- Sherwood Industries Ltd. and its employees or representatives will not assume any damages, either directly or indirectly caused by improper usage, operation, installation, servicing or maintenance of this appliance.
- A proof of original purchase must be provided by you or the dealer.

Exclusions

An expanded list of exclusions is available at www.enviro.com/help/warranty.html

This warranty does not cover:

- Damage as a result of improper usage or abuse.
- Damage caused from over-firing due to incorrect setup or tampering.
- Damage caused by incorrect installation.

To the Dealer

- Provide name, address and telephone number of purchaser and date of purchase.
- Provide date of installation. Name of installer and dealer. Serial number of the appliance. Nature of complaint, defects or malfunction, description and part # of any parts replaced.

To the Distributor

- Sign and verify that work and information are correct.

Sherwood Industries Ltd.

6782 Oldfield Road, Victoria, BC . Canada V8M 2A3

Online warranty registration: www.enviro.com/warranty/

Category	One Year	Two Year	Limited Lifetime (7yr)
Parts ¹ & Labour	✓	✓	✓
FireBOX (excluding bricks)	✓	✓	✓
Ceramic Baffle ²	✓	✓	✓
Secondary Air Tubes	✓	✓	✓
Surround Panels (excluding finish)	✓	✓	✓
Pedestals / Legs (excluding finish)	✓	✓	✓
Ceramic Glass ³	✓		
Door Assembly	✓	✓	✓
Slider Control	✓	✓	✓
Shield Assembly	✓	✓	✓ (No labour after 3 years)
Electrical Components	✓	✓	
Convection Fan	✓	✓	
Exterior Surface Finishing ⁴	✓		

¹ Second replacement part – 1 year, labour not included

² Excludes damage caused by loading wood, cleaning or service

³ Glass is covered only for thermal breakage

⁴ Exterior Surface finishing covers Plating, Enamel or Paint and excludes colour changes, chipping, and fingerprints

INSTALLATION DATA SHEET

The following information must be recorded by the installer for warranty purposes and future reference.

NAME OF OWNER: _____
ADDRESS: _____ _____ _____
PHONE: _____

NAME OF DEALER: _____
ADDRESS: _____ _____ _____
PHONE: _____

MODEL: _____
SERIAL NUMBER: _____
DATE OF PURCHASE: _____ (dd/mm/yyyy)
DATE OF INSTALLATION: _____ (dd/mm/yyyy)
INSTALLER'S SIGNATURE: _____

NAME OF INSTALLER: _____
ADDRESS: _____ _____ _____
PHONE: _____

MANUFACTURED BY:
SHERWOOD INDUSTRIES LTD.
6782 OLDFIELD RD. SAANICHTON, BC, CANADA V8M 2A3
www.enviro.com
October 4, 2011
C-12591