



Vent Free Gas Log Sets

INSTALLATION & USER'S MANUAL

Burner Models: VF18V-NG, VF18V-LP, VF24V-NG, VF24V-LP, VF18E-NG, VF18E-LP, VF24E-NG, VF24E-LP
SIZES: 18 or 24



WARNING

THIS APPLIANCE IS EQUIPPED FOR EITHER NATURAL GAS OR PROPANE GAS. FIELD CONVERSION IS NOT PERMITTED



ANS Z21.11.2-2019,
ANS Z21.60-2017 – CSA
2.26-2017

Report # F19-108



WARNING: If the information in this manual is not followed exactly, a fire or explosion may result, causing property damage, personal injury, or loss of life.

– Do not store or use gasoline or other flammable vapors and liquids in the vicinity of this or any other appliance.

– WHAT TO DO IF YOU SMELL GAS

- Do not try to light any appliance
- Do not touch any electrical switch; do not use any phone in your building.
- Immediately call your gas supplier from a neighbor's phone. Follow the gas supplier's instructions.
- If you cannot reach your gas supplier, call the fire department.

– Installation and service must be performed by a qualified installer, service agency or gas supplier.

This is an UNVENTED gas-fired heater. It uses air (oxygen) from the room in which it is installed. Provisions for adequate combustion and ventilation air MUST be provided. Refer to "SAFETY INFORMATION" in Section 2.0 of this manual.

**INSTALLER: Leave this manual with the appliance.
CONSUMER: Retain this manual for future reference.**

Contents

- Serial Decals..... 3**
- Introduction 7**
 - General..... 7
 - Technology & Specifications 7
 - ✓ Specifications..... 7
 - 1...1 Gas Types.....7
 - 1...2 Ignition Type.....7
 - 1...3 Pilot Type7
 - 1...4 Controllable Features.....7
 - 1...5 Sizing and Gas Pressures.....7
- Safety Information..... 9**
- Usage Instructions..... 11**
 - Pre-Usage Information 11
 - ✓ Guidelines..... 11
 - Operating This Appliance Safely 11
 - Lighting Instructions 12
 - ✓ Lighting Inst., Millivolt Variable Control.... 13
 - 1...1 Manual Mode 14
 - 1...2 Thermostat Mode 14
 - ✓ Lighting Instr., Variable Electronic 15
 - Cleaning and Servicing 16
 - ✓ Monthly Cleaning..... 16
- Pre-Installation Instructions..... 17**
 - General..... 17
 - Pre-Installation Precautions & Safety..... 17
 - Burner System Requirements 17
 - Vented Installation Restrictions 18
 - Unvented Installation Restrictions 18
 - ✓ Determining a Confined Space..... 18
 - ✓ Installing in a Confined Space 19
 - Clearances to Combustibles 20
 - ✓ Clearance IN FRONT 20

- ✓ Clearance ABOVE 20
- Fitting the Unit..... 21
 - ✓ Location..... 21
 - ✓ Mounting Clearances 21
 - ✓ Optional Chimney Venting 21
 - ✓ Product Installation Illustration 21
 - ✓ Product Dimensions 21
- Mantel Clearances 22**
 - Preparation 23
 - ✓ Unpacking 23
 - ✓ Gas Connections..... 23
- Installation..... 24**
 - Installation Safety Information..... 24
 - ✓ Fireplace Floor Requirements 24
 - ✓ Installing the Burner Unit..... 25
 - ✓ Installing the Remote Control..... 26
 - 1...1 Installing the Millivolt Variable Remote 26
 - 1...2 Installing the Variable Electronic Ignition Remote 27
 - ✓ Setting the Controls..... 28
 - ✓ Checking the Gas Pressure 28
 - ✓ Placing Decorative Media 29
 - 1...1 Placing Glowing Embers..... 29
 - 1...2 Placing Lava Rock..... 29
 - 1...3 Making the Media Consistent 29
 - ✓ Log Set Placement..... 29
- Gas Maintenance 30**
- Troubleshooting 31**
 - Vent-Free Logs Parts List.... **Error! Bookmark not defined.**
 - Vent Free Burner System Replacement Parts List 40
- Indoor Gas Limited Lifetime Warranty..... 45**

Serial Decals

This is a copy of the label that normally accompanies this gas burner. We have printed a copy of the contents here for your review. The safety label is located near the gas burner. The serial # will be a total of 9 digits. The first 3 digits (as noted below) represent the model of the gas burner.

NOTE: Regency® units are constantly being improved. Check the label on the unit and if there is a difference, the label on the unit is the correct one.

Serial Decal for Model # VF18V-LP/VF18E-LP



MODEL NO.
VF18V-LP/VF18E-LP

GAS TYPE
PROPANE

SERIAL NO.
594

Report Number F19-108



| | | |
|-------------------|-------------------------------|---|
| Manifold Pressure | Min. Inlet 11.0" w.c. 2.74kPa | ANS Z21.11.2-2019 Unvented Room Heater |
| 10" w.c. 2.49kPa | Max. Inlet 13.0" w.c. 3.24kPa | ANS Z21.60-2017 - CSA 2.28-2017 Vented Decorative Appliance |

| MINIMUM FIREPLACE DIMENSIONS | | | | |
|------------------------------|-------|--------|-------|------|
| | | | WIDTH | |
| MODEL | DEPTH | HEIGHT | FRONT | REAR |
| 18" | 13" | 18" | 22" | 20" |

| SIZE | BTU | KW |
|------|-----------------|-------------|
| 18" | 24,000 - 32,000 | 7.03 - 9.38 |

ATTENTION:
This heater may NOT be installed in a bedroom or bathroom!

WARNING: Improper installation, adjustment alteration, service or maintenance can cause property damage, personal injury or loss of life. Refer to the owner's information manual provided with this gas heater. Installation and service must be performed by a qualified installer, service agency or the gas supplier.

| | | |
|---|---|--|
| <p>FOR YOUR SAFETY: Do not store or use gasoline or other flammable vapors and liquids in the vicinity of this or any other appliance. Explosion or fire could result.</p> | <p>IMPORTANT For safe operation of this appliance, a minimum gas inlet pressure of 11" water column (w.c.) (2.74 kPa) is required.</p> | <p>Do NOT apply extra material or material not supplied with the heater. Replace ONLY with black glowing embers and Platinum bright embers. Apply loose material per the instruction manual.</p> |
|---|---|--|

This appliance shall not be field converted.

CAUTION: Hot while in operation. Do not touch. Keep children, clothing, furniture, gasoline and other liquids having flammable vapors away.

CAUTION: This burner is designed and certified to operate on Propane Gas with a heating value of 2550 +/- 50 BTU's per cubic foot.

This appliance may be installed in an aftermarket, permanently located, manufactured (mobile) home, where not prohibited by local codes.

This appliance is only for use with the type of gas indicated on the rating plate. This appliance is not convertible for use with other gases.

Keep burner & control components clean, SEE installation and operating instructions accompanying this heater.

THIS appliance is intended for supplemental heating

Failure to position the parts in accordance with these diagrams, or failure to use only parts specifically approved with this heater, may result in property damage or personal injury.

WARNING: This appliance has been certified for indoor use only.



This is a copy of the label that normally accompanies this gas burner. We have printed a copy of the contents here for your review. The safety label is located near the gas burner. The serial # will be a total of 9 digits. The first 3 digits (as noted below) represent the model of the gas burner.

NOTE: Regency® units are constantly being improved. Check the label on the unit and if there is a difference, the label on the unit is the correct one.

Serial Decal for Model # VF24V-LP/VF24E-LP



MODEL NO.
VF24V-LP/VF24E-LP

GAS TYPE
PROPANE

SERIAL NO.
595

Report Number F 19-108



| | |
|-------------------|-------------------------------|
| Manifold Pressure | Min. Inlet 11.0" w.c. 2.74kPa |
| 10" w.c. 2.49kPa | Max. Inlet 13.0" w.c. 3.24kPa |

| | | |
|---|--|--|
| ANS Z21.11.2-2019 Unvented Room Heater | | |
| ANS Z21.60-2017 - CSA 2.26-2017 Vented Decorative Appliance | | |

| MINIMUM FIREPLACE DIMENSIONS | | | | |
|------------------------------|-------|--------|-------|------|
| WIDTH | | | | |
| MODEL | DEPTH | HEIGHT | FRONT | REAR |
| 24" | 14" | 18" | 28" | 20" |

| SIZE | BTU | KW |
|--------|-----------------|--------------|
| 24/30" | 19,000 - 37,000 | 5.57 - 10.84 |

ATTENTION:
This heater may NOT be installed in a bedroom or bathroom!

WARNING: Improper installation, adjustment alteration, service or maintenance can cause property damage, personal injury or loss of life. Refer to the owner's information manual provided with this gas heater. Installation and service must be performed by a qualified installer, service agency or the gas supplier.

| | | |
|---|---|--|
| <p>FOR YOUR SAFETY: Do not store or use gasoline or other flammable vapors and liquids in the vicinity of this or any other appliance. Explosion or fire could result.</p> | <p>IMPORTANT For safe operation of this appliance, a minimum gas inlet pressure of 11" water column (w.c.) (2.74 kPa) is required.</p> | <p>Do NOT apply extra material or material not supplied with the heater. Replace ONLY with black glowing embers and Platinum bright embers. Apply loose material per the instruction manual.</p> |
|---|---|--|

This appliance shall not be field converted.

CAUTION: Hot while in operation. Do not touch. Keep children, clothing, furniture, gasoline and other liquids having flammable vapors away.

CAUTION: This burner is designed and certified to operate on Propane Gas with a heating value of 2550 +/- 50 BTU's per cubic foot.

This appliance may be installed in an aftermarket, permanently located, manufactured (mobile) home, where not prohibited by local codes.

This appliance is only for use with the type of gas indicated on the rating plate. This appliance is not convertible for use with other gases.

Keep burner & control components clean, SEE installation and operating instructions accompanying this heater.

THIS appliance is intended for supplemental heating

Failure to position the parts in accordance with these diagrams, or failure to use only parts specifically approved with this heater, may result in property damage or personal injury.

WARNING: This appliance has been certified for indoor use only.



This is a copy of the label that normally accompanies this gas burner. We have printed a copy of the contents here for your review. The safety label is located near the gas burner. The serial # will be a total of 9 digits. The first 3 digits (as noted below) represent the model of the gas burner.

NOTE: Regency® units are constantly being improved. Check the label on the unit and if there is a difference, the label on the unit is the correct one.

Serial Decal for Model # VF18V-NG/VF18E-NG



MODEL NO.
VF18V-NG/VF18E-NG

GAS TYPE
NATURAL GAS

SERIAL NO.
597
Report Number F19-108



| | |
|--------------------|-------------------------------|
| Manifold Pressure | Min. Inlet 5.0" w.c. 1.25kPa |
| 3.5" w.c. 0.875kPa | Max. Inlet 10.5" w.c. 2.62kPa |

| | | |
|---|--|--|
| ANS Z21.11.2-2019 Unvented Room Heater | | |
| ANS Z21.60-2017 - CSA 2.26-2017 Vented Decorative Appliance | | |

| MINIMUM FIREPLACE DIMENSIONS | | | | |
|------------------------------|-------|--------|-------|------|
| WIDTH | | | | |
| MODEL | DEPTH | HEIGHT | FRONT | REAR |
| 18" | 13" | 18" | 22" | 20" |

| SIZE | BTU | KW |
|------|-----------------|--------------|
| 18" | 26,000 - 35,000 | 7.62 - 10.26 |

ATTENTION:
This heater may NOT be installed in a bedroom or bathroom!

WARNING: Improper installation, adjustment alteration, service or maintenance can cause property damage, personal injury or loss of life. Refer to the owner's information manual provided with this gas heater. Installation and service must be performed by a qualified installer, service agency or the gas supplier.

| | | |
|---|--|--|
| <p>FOR YOUR SAFETY: Do not store or use gasoline or other flammable vapors and liquids in the vicinity of this or any other appliance. Explosion or fire could result.</p> | <p>IMPORTANT For safe operation of this appliance, a minimum gas inlet pressure of 5" water column (w.c.) (1.25 kPa) is required.</p> | <p>Do NOT apply extra material or material not supplied with the heater. Replace ONLY with black glowing embers and Platinum bright embers. Apply loose material per the instruction manual.</p> |
|---|--|--|

This appliance shall not be field converted.

CAUTION: Hot while in operation. Do not touch. Keep children, clothing, furniture, gasoline and other liquids having flammable vapors away.

CAUTION: This burner is designed and certified to operate on Propane Gas with a heating value of 2550 +/- 50 BTU's per cubic foot.

This appliance may be installed in an aftermarket, permanently located, manufactured (mobile) home, where not prohibited by local codes.

This appliance is only for use with the type of gas indicated on the rating plate. This appliance is not convertible for use with other gases.

Keep burner & control components clean, SEE installation and operating instructions accompanying this heater.

THIS appliance is intended for supplemental heating

Failure to position the parts in accordance with these diagrams, or failure to use only parts specifically approved with this heater, may result in property damage or personal injury.

WARNING: This appliance has been certified for indoor use only.



This is a copy of the label that normally accompanies this gas burner. We have printed a copy of the contents here for your review. The safety label is located near the gas burner. The serial # will be a total of 9 digits. The first 3 digits (as noted below) represent the model of the gas burner.

NOTE: Regency® units are constantly being improved. Check the label on the unit and if there is a difference, the label on the unit is the correct one.

Serial Decal for Model # VF24V-NG/VF24E-NG



MODEL NO.
VF24V-NG/VF24E-NG

GAS TYPE
NATURAL GAS

SERIAL NO.
596

Report Number F 19-108



| | |
|--------------------|-------------------------------|
| Manifold Pressure | Min. Inlet 11.0" w.c. 2.74kPa |
| 3.5" w.c. 0.875kPa | Max. Inlet 13.0" w.c. 3.24kPa |

| | | |
|---|--|--|
| ANS Z21.11.2-2019 Unvented Room Heater | | |
| ANS Z21.60-2017 - CSA 2.26-2017 Vented Decorative Appliance | | |

| MINIMUM FIREPLACE DIMENSIONS | | | | |
|------------------------------|-------|--------|-------|------|
| WIDTH | | | | |
| MODEL | DEPTH | HEIGHT | FRONT | REAR |
| 24" | 14" | 18" | 28" | 20" |

| SIZE | BTU | KW |
|--------|-----------------|--------------|
| 24/30" | 19,000 - 37,000 | 5.57 - 10.84 |

ATTENTION:
This heater may NOT be installed in a bedroom or bathroom!

WARNING: Improper installation, adjustment alteration, service or maintenance can cause property damage, personal injury or loss of life. Refer to the owner's information manual provided with this gas heater. Installation and service must be performed by a qualified installer, service agency or the gas supplier.

| | | |
|--|--|---|
| FOR YOUR SAFETY: Do not store or use gasoline or other flammable vapors and liquids in the vicinity of this or any other appliance. Explosion or fire could result. | IMPORTANT For safe operation of this appliance, a minimum gas inlet pressure of 5" water column (w.c.) (1.25 kPa) is required. | Do NOT apply extra material or material not supplied with the heater. Replace ONLY with black glowing embers and Platinum bright embers. Apply loose material per the instruction manual. |
|--|--|---|

This appliance shall not be field converted.

CAUTION: Hot while in operation. Do not touch. Keep children, clothing, furniture, gasoline and other liquids having flammable vapors away.

CAUTION: This burner is designed and certified to operate on Propane Gas with a heating value of 2550 +/- 50 BTU's per cubic foot.

This appliance may be installed in an aftermarket, permanently located, manufactured (mobile) home, where not prohibited by local codes.

This appliance is only for use with the type of gas indicated on the rating plate. This appliance is not convertible for use with other gases.

Keep burner & control components clean, SEE installation and operating instructions accompanying this heater.

THIS appliance is intended for supplemental heating

Failure to position the parts in accordance with these diagrams, or failure to use only parts specifically approved with this heater, may result in property damage or personal injury.

WARNING: This appliance has been certified for indoor use only.



Introduction

This document provides user and installation information for the Regency Vent Free Log Sets. It is intended to be installed as an unvented supplemental heating appliance in a new or existing site.

➤ General

It is important that you read and follow these instructions carefully if intending to use or install this appliance. Pay close attention to all safety and operational instructions contained in this document.

➤ Technology & Specifications

- Lifelike coals and flaming logs are created by applying a flame source to the appropriate media.
- Because it uses gas (LP or Natural), the fire also provides heat that is radiated from the hot media elements within an enclosure.
- The output is at such a level that a vent is not required (as long as safety conditions are met).

✓ Specifications

1...1 Gas Types

- Natural
- LP (Propane)

1...2 Ignition Type

- Manual Hand-Held Flame Source can be used on all models as backup for Piezo lighter
- Manual Piezo (Continuous Pilot Light) used on the “*Millivolt Variable Control*” models
- Automatic Piezo (Non-Continuous Pilot Light) used on the “*Variable Electronic*” models

1...3 Pilot Type

ODS (Oxygen Depletion Sensing)

1...4 Controllable Features

- Wireless remote control
- Flame On/Off, manual
- Flame On/Off, remote thermostatic setting
- Flame height and intensity, manual setting
- Flexible Media Placement

1...5 Sizing and Gas Pressures

Refer to Tables 1 & 2 for sizing information and gas pressures/BTU ratings for the various models. Note that the gas pressure requirements do not change for the 2 types of valve and control options that are offered.

Important: For safe operation and proper performance of this product and to comply with certification, listings, and building code acceptances, use ONLY Regency controls, parts & accessories that have been specifically listed or certified for use with this burner system. Use of other controls, parts, or accessories is prohibited and will void all warranties, certifications, listings and building code approvals, and may cause property damage, personal injury, and loss of life.



| Minimum Size Requirements | | | | | | | | |
|--|------------------------|------|-------|--------|-------------|--------------|-------------|--------------|
| Burner Model | Minimum Fireplace Size | | | | BTU Ratings | | | |
| | Width | | Depth | Height | Natural Gas | | Propane Gas | |
| | Front | Rear | | | Low Setting | High Setting | Low Setting | High Setting |
| VF18V-NG Vent-Free Burner Millivolt Variable 18 NG VF18V-LP Vent-Free Burner Millivolt Variable 18 LP VF18E-NG Vent-Free Burner Electronic 18 NG VF18E-LP Vent-Free Burner Electronic 18 LP | 22" | 20" | 13" | 18" | 26k | 35k | 24k | 32k |
| VF24V-NG Vent-Free Burner Millivolt Variable 24 NG VF24V-LP Vent-Free Burner Millivolt Variable 24 LP VF24E-NG Vent-Free Burner Electronic 24 NG VF24E-LP Vent-Free Burner Electronic 24 LP | 28" | 20" | 14" | 18" | 19k | 37k | 19k | 37k |

TABLE 1

| GAS PRESSURE SPECIFICATIONS | | | |
|--|-------------------------------|--|-----------------------------|
| NATURAL GAS | | PROPANE GAS | |
| Outlet pressure reading: (Flame adjustment on high) | Typical 3.5" w.c | Outlet pressure reading: (Flame adjustment on high) | Typical 10.0" w.c |
| Inlet pressure reading | Max. 10.5" w.c Min. 5" w.c | Inlet pressure reading | Max 13" w.c Min. 11" w.c |

TABLE 2

| AERATION SETTINGS (EMBER BED & MAIN BURNER) | |
|---|-------------|
| NATURAL GAS | PROPANE GAS |
| 1/4" open | 1/4" open |

TABLE 3

Safety Information

UNVENTED ROOM HEATER GENERAL SAFETY INFORMATION:

1. Due to high temperatures, this appliance should be located out of traffic and away from furniture/draperies.
2. Children and adults should be alerted to the hazard of high surface temperatures and should stay away to avoid burns or clothing ignition.
3. Young children should be carefully supervised when in the same room with this appliance.
4. Do not place clothing or any flammable material on or near your vent-free gas appliance. Matches, paper, garbage or any other material must not be thrown on top of the logs, burner or into the flame.
5. Any safety screen, guard, or barrier removed for servicing this appliance must be replaced prior to operating the heater.
6. Installation and repair should be done by a qualified service person. The appliance should be inspected before use and at least annually by a professional service person. More frequent cleaning may be required due to excessive lint from carpeting, bedding material etc. It is imperative that control compartments, burners, and circulating air passageways of the appliance be kept clean.

7.



WARNING: FIRE, EXPLOSION, AND ASPHYXIATION HAZARD

Improper adjustment, alteration, service, maintenance, or installation of this heater or its controls can cause death or serious injury.

Read and follow Instructions and precautions in this User's Information Manual provided with this heater

IMPORTANT - CO Detectors:

Make sure your home has a working CO detector, especially near any bedrooms. We recommend having a CO detector in the same room as the gas burner for additional safety. Location of both detectors should be chosen wisely to avoid false alarms.

8.

This appliance is intended for supplemental heating.

9. Do not block air intakes any manner and maintain adequate clearances to enable the free flow of air.
10. This heater shall not be installed in a room or space unless the required volume of indoor combustion air is provided by the method described in the *National Fuel Gas Code*, ANSI Z223.1/NFPA 54, the *International Fuel Gas Code*, or applicable local codes.
11. Provide adequate clearances for servicing and operation.
12. Do not install this appliance directly on combustible flooring. Be certain that the top surface of the combustible flooring material (i.e. carpet, tile, etc.) is not too close to this gas appliance. If this appliance is at floor level or less than 6" above the top surface of the flooring material, there must be at least 12" of noncombustible material between the base of the fireplace and any surface of the combustible flooring.

13. At least 10"-12" of noncombustible or heat-resistant material is required above the fireplace. A fireplace hood will be required to act as a heat deflector in protecting combustible fireplace surrounds (facing and/or mantel) if certain minimum clearances cannot be met. See the "Clearances to Combustibles" section / Mantel Clearances (figure 14) in this manual.
14. A vent-free room heater having an input exceeding 10,000 BTU per hour (2,931 Watts) shall not be installed in a bedroom or bathroom (ANSI Z21.11.2). This includes ALL models in this manual.
15. A vent-free room heater having an input exceeding 6,000 BTU per hour (1,758 Watts) shall not be installed in a bathroom (ANSI Z21.11.2). This includes ALL models in this manual.
16. **WARNING:** Failure to keep the primary air opening(s) of the burner(s) clean may result in sooting and property damage.
17. **WHEN INSTALLING AS A DECORATIVE VENTED APPLIANCE, THE UNIT MUST CONFORM TO ALL LOCAL CODES OR, IN THE ABSENCE OF LOCAL CODES, TO THE NATIONAL FUEL GAS CODE ANSI Z223.1/NFPA 54.**
18. The appliance and its appliance main gas valve must be disconnected from the gas supply piping system during any pressure testing of that system at test pressure in excess of ½ psi (3.5 kPa). The appliance must be isolated from the gas supply piping system by closing its equipment shutoff valve during any pressure testing of the gas supply piping system at test pressure equal to or less than ½ psi (3.5 kPa).
19. Keep the area around your gas appliance clear of combustible materials, gasoline, and any other flammable vapors/liquids. Be especially cautious if the gas appliance is installed in a basement or converted garage.
20. Do not use this appliance if any part has been underwater. Immediately call a qualified professional service technician to inspect the appliance and to replace a part of the control system and any gas control which has been under water.
21. Perform a periodic visual check of the pilot and burner flame. It should appear as shown in Figure 1.
22. **WARNING:** This appliance is for installation only in a solid-fuel burning masonry or UI 127 factory-built fireplace or in a listed ventless firebox enclosure. It has been design certified for these installations.
Exception: DO NOT Install this appliance in a factory-built fireplace that includes instructions stating it has not been tested or should not be used with unvented gas logs.
23. **WARNING:** Before installing in a solid-fuel burning fireplace, the chimney flue, damper and firebox must be thoroughly **CLEANED** of soot, creosote, ash, and loose paint by a qualified chimney cleaner.
24. **WARNING: DO NOT ALLOW FANS TO BLOW DIRECTLY INTO THE FIREPLACE. AVOID ANY DRAFTS THAT ALTER FLAME PATTERNS.**
25. **WARNING: DO NOT USE A BLOWER INSERT, HEATER EXCHANGER INSERT, OR OTHER ACCESSORY NOT APPROVED FOR USE WITH THIS HEATER.**
26. A fireplace screen must be in place when this appliance is operating, unless other provisions for combustion air are provided, the screen has an opening(s) for introduction of combustion air.
27. It is important to use the gas logs based on the minimum size fireplace as indicated in the "Product Drawing" section showing the height and width of the front opening and depth.
28. **SOLID-FUEL MUST NOT BE BURNED** in the fireplace where this unvented gas appliance is installed.
29. **GLASS DOORS MUST BE FULLY OPEN** when this vent-free gas appliance is operating. This appliance **MUST NOT BE ON** if glass doors are closed, as it can lead to sooting, burner outages and possibly explosion, causing damage or injury.
30. Any outside air ducts and/or ash dumps located on the floor or walls of the fireplace must be permanently sealed shut before the installation. Use heat-resistant sealant. Do not seal chimney flue damper.

31. **STATE AND LOCAL CODES MAY ONLY ALLOW OPERATION OF THIS APPLIANCE IN A VENTED CONFIGURATION. CHECK YOUR STATE OR LOCAL CODES.**

32. **WARNING: CARBON MONOXIDE POISONING MAY LEAD TO DEATH.**

Early signs of carbon monoxide poisoning are similar to the flu, with headaches, dizziness, and/or nausea. If you have these signs, the gas appliance may not be installed correctly, or may not be working properly.

GET FRESH AIR AT ONCE! STOP USING THE APPLIANCE IMMEDIATELY!

Some people, including pregnant women; persons with heart or lung disease, asthma, or anemia; those under the influence of alcohol; and persons at high altitudes, are more affected by carbon monoxide than others. **(The appliance must be serviced by a qualified professional service technician before use).**

33. If any soot appears on the appliance or other areas of the fireplace in which this appliance is installed, shut the system off and call a qualified professional service technician, **vent-free gas burner system technician**, or your local gas company.

34. This appliance may be installed in an aftermarket, permanently located, manufactured (mobile) home where not prohibited by local codes. Installation of appliances designed for manufactured homes or mobile homes must conform with *Manufactured Home Construction and Safety Standards, Title 24 CFR, Part 3280 in the U.S.*; or with *CAN/CSA Z240 MH, Mobile Housing in Canada*; or with *ANSI/NCSCS A225.1/NFPA 501A, Manufactured Home Installations Standard* when none of the previously referenced standards are applicable.

35. This appliance has been certified for indoor use only.

36. This product certified and listed is for use in the USA only.

WARNING: THIS APPLIANCE IS EQUIPPED FOR EITHER NATURAL GAS OR PROPANE GAS. FIELD CONVERSION IS NOT PERMITTED.

Usage Instructions

➤ Pre-Usage Information

Please read the information below before using this appliance. It is important that you fully understand how to operate the controls, provide adequate ventilation, and know how to safely light this product before using.

✓ Guidelines

It is imperative that you maintain your unvented gas appliance by having it cleaned and serviced regularly.

This burner system is equipped with an Oxygen Depletion Sensor (ODS) safety pilot system. The ODS senses the amount of oxygen available in the room and shuts the burner system off before the oxygen level drops below 18%.

The pilot can only be relit when fresh air is available. **This may require opening a window or a door to another room or cracking the damper open slightly.**

When using fireplaces, basic precautions should always be followed to reduce the risk of fire and injury to persons, including the following:

1. Read all instructions before installing or using this appliance.
2. Internal components are hot when in use. To avoid burns, do not let bare skin touch hot surfaces.
3. May be used indoors only.
4. To disconnect, turn controls to OFF.
5. **Do not block exhaust openings and always allow for adequate flow.**
6. Use this appliance only as described in this manual. Any other use not recommended by the manufacturer may cause fire, shock or injury to persons.
7. **SAVE THESE INSTRUCTIONS**

➤ Operating This Appliance Safely

Please read the information below carefully before operating your unvented gas appliance. This appliance must be operated correctly to prevent loss or damage.

WARNING!

Do not operate this appliance if damaged or has malfunctioned. Call a qualified service technician to inspect it. Replace any part of the system as necessary before reuse.

1. Make sure there is adequate combustion and ventilation air when this gas appliance is operating. You may need to crack damper or open window slightly.
2. **THIS APPLIANCE MUST BE MAINTAINED IN A WELL-CLEANED CONDITION AT ALL TIMES. REGULAR (AT LEAST ONCE PER YEAR) CLEANING OF THE BURNER AND ODS PILOT IS REQUIRED BY A QUALIFIED PROFESSIONAL SERVICE TECHNICIAN.**
3. To light this appliance, it may be necessary to purge the unit for longer than one minute after long periods of non-use.
4. If you operate this vent-free gas appliance fueled by LP, operating characteristics may vary as the fuel in the tank approaches empty (**less than ¼ full**). Sooting and other increases in combustion by-products will occur. If this happens, turn off the appliance, refill the LP tank, and have the burner cleaned.
5. During manufacturing, various parts of this unit are treated with oils or paints. Though not harmful, they may produce annoying smoke and smells as they are burned off during initial operation. This is a normal occurrence. Initial break-in period should last four to six hours; maximum ventilation should be provided by opening windows, doors, or chimney flue.
6. If the gas quality is poor or pressure low, your ODS pilot may not stay lit, the burners may produce soot, or the unit may backfire. Contact your local gas supplier immediately.
7. **This appliance is designed for adults to be present while in operation. Do not leave this unit burning when unattended or while anyone is sleeping. This is an attended appliance.**
8. Burning candles, air fresheners and sprays will cause objectionable odors to be created by the unvented burner system.

➤ **Lighting Instructions**

FOR YOUR SAFETY. READ BEFORE LIGHTING

WARNING

If you do not follow these instructions exactly, a fire or explosion may result, causing property damage, personal injury or loss of life

Do not use this appliance if any part has been underwater. Immediately call for a qualified professional service technician to inspect the appliance and to replace any part of the control system and any gas control that has been underwater

BEFORE LIGHTING, smell around the gas burner system area for gas. Be sure to smell next to the floor, as some gas is heavier than air and will settle on the floor. **IF YOU SMELL GAS, FOLLOW INSTRUCTIONS ON THE COVER PAGE OF THIS MANUAL.**

Use only your hand to push in or turn gas control knobs. Never use tools. If a knob will not push in or turn by hand, don't try to repair it. Call a qualified professional service technician. Forcing any controls or attempting repairs may result in fire or explosion.

For each of the lighting options described below, adjust the gas flow to have the appearance and flame height as shown in Figure 1. It is important to have a flame that is balanced with glowing embers on the bottom and flames that do not extend too much above the logs. Observe the flames. The main burner flames should be blue at the base and a combination of blue/yellow at the body and the tips. They should be 5" to 8" above the logs, with the center flame being the tallest. Front flames in the ember burner should be ¼" above the embers.



Figure 1

NOTE: The Regency burner system uses an Oxygen Depletion Sensing (ODS) pilot as shown in Figure 2

(Millivolt Variable Control & Variable Electronic).
When starting the ODS pilot, follow the instructions that pertain to your log set model exactly.

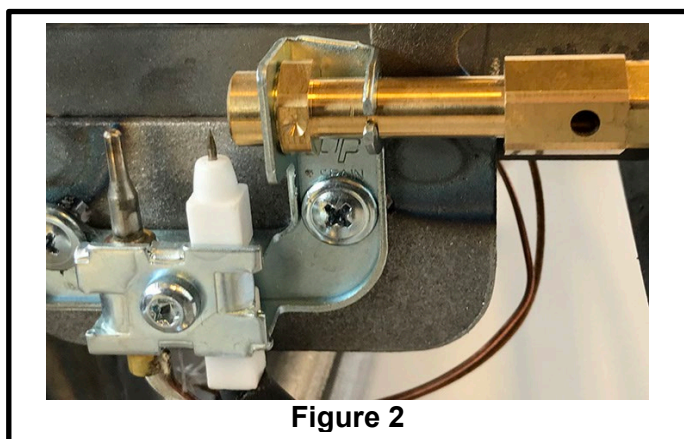

Figure 2

The angle of the pilot flame touching the thermocouple, as set by the factory, is very important to maintain. The alignment and orientation of the ODS pilot is slightly different when the burner is equipped for Natural or Propane gas sources (Figure 3). This should be checked periodically while the pilot is on.

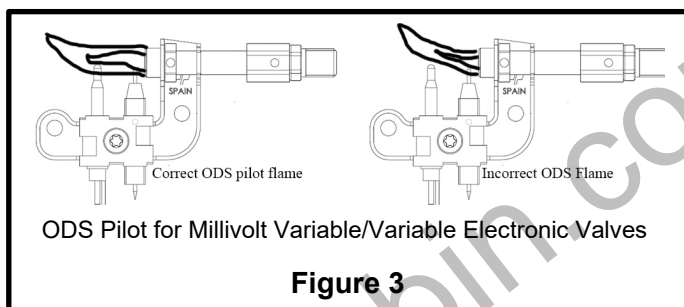







Figure 3

✓ **Lighting Inst., Millivolt Variable Control**

In this section, refer to Figure 4 for the gas valve and Figure 5 for the remote control while doing the following lighting steps for the Millivolt Variable Control burner system:

1. Turn the Flame Height Control Knob (bottom knob) clockwise  as far as it will go to reach the "OFF" position.
2. Verify that no gas is present around the fireplace or burner area (this could take 5 minutes to clear if present).
3. If you still detect gas **STOP!** Then follow the "WHAT TO DO IF YOU SMELL GAS" instructions found on the cover page of this manual.

4. Turn the Pilot Ignitor Knob (the top knob) counterclockwise  to the "IGN" (ignition) position.
5. While in the "IGN" position, push the knob in as far as it will go. This action releases gas flow to the ODS pilot.
6. While still holding in the Pilot Ignitor Knob in, turn it counterclockwise  to the "PILOT" position.
7. This will click, then activate the spark ignitor on the pilot and cause a spark at the pilot which will ignite the pilot gas.
8. If the spark does not work after repeating steps 5-7, light the pilot with a match.
9. **Note:** When lighting the pilot, it may be necessary to push the Pilot Ignitor Knob in for as long as 30 seconds to allow gas time to reach the pilot before it will light.
10. Continue to hold the Pilot Ignitor Knob in all the way for about 30 seconds after the pilot is lit.
11. Release the knob and it will pop back out. The pilot should remain lit. If it goes out, repeat steps 4 thru 7.
12. **Note:** If the knob does not pop up when released, **STOP!** The gas valve needs to be serviced by a Certified Repair Tech.
13. **Note:** If the pilot does not stay lit after several tries, turn the gas control knob "OFF" and **STOP!** The gas valve needs to be serviced by a Certified Repair Tech.
14. Turn the Flame Height Control Knob (bottom knob) counterclockwise  to "ON". Then turn the Flame Height Control Knob clockwise  to verify that the correct flame height may be properly controlled.
15. Turn the Flame Height Control Knob to the OFF position.

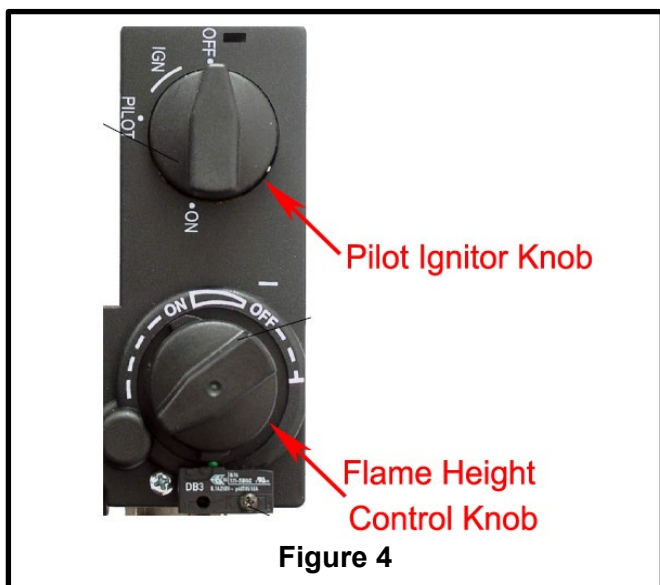

Figure 4

Now that the flame control has been verified, refer to the next section to use the remote control to control the burner. With the remote, the flame may either be adjusted manually using buttons or automatically using a thermostatic setting.

IMPORTANT: The Flame Height Control Knob has an interlock device. After shutting off all gas flow, the pilot burner cannot be relit until the thermocouple has cooled (Approx.60 sec.). The Flame Height Control Knob is designed to be operated by hand. DO NOT use any tools during this operation. Damaged knobs may result in serious injury.

If you expect to not use the burner for an extended period of time, turn both knobs to the “OFF” position to completely extinguish the ODS pilot and main burner. Then shut off the gas supply line valve to the fireplace.

1...1 Manual Mode

To operate the system in the “MANUAL MODE” do the following:

TURNING THE FLAME ON

1. Press and hold the ON/HI key until the flame comes on and reaches the desired flame height or is burning at full on.
2. Initially, the display will show “HI”, but after 3 seconds it will default to display the room temperature and the word “TEMP” will be shown.

TURNING THE FLAME OFF

1. Press and hold the LO/OFF key until the flame reaches the desired flame height or completely shuts off.

2. Initially, the display will show “LO”, but after 3 seconds, the display will default to show the room temperature and the word “TEMP” will be shown.

Note: The “Flame” icon will show on the display when in Manual Mode.

1...2 Thermostat Mode

The remote control can be used to thermostatically control the flame height to automatically set the room temperature.

To operate the system in the “THERMOSTAT MODE”, and set a desired room temperature, do the following:

SETTING DESIRED ROOM TEMPERATURE

1. Press the MODE key until the display shows the word “ROOM”; the remote is now in the Thermostat Mode.
2. Press and hold the SET key until the desired set temperature is reached. (The display will show temperature numbers increasing from 45F to 99F, then restarting over at 45F.)
3. When the desired temperature shows on the display, release the SET key.
4. Initially, the display will show the temperature that has been set, but after 3 seconds, the display will flash the set temperature for 3 more seconds.
5. Then, the display will default to show the room temperature.

Note: The word “ROOM” will show on the display when in Thermostat Mode.

TO CHANGE THE SET TEMPERATURE

To make a change to an existing temperature setting, start at Step 2 in the previous instructions for “SETTING DESIRED ROOM TEMPERATURE”.

NOTE: The highest SET temperature is 99 degrees Fahrenheit (32 degrees Celsius) and the lowest temperature is (45 degrees Fahrenheit (6 degrees Celsius)

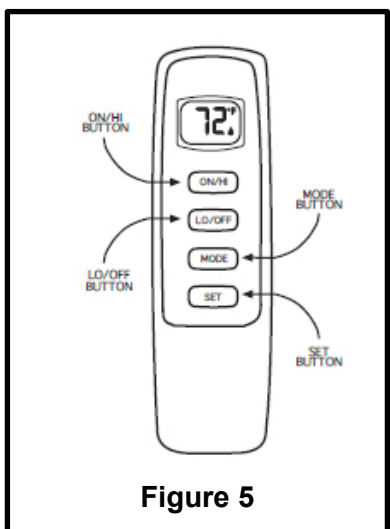

Figure 5





✓ Lighting Instr., Variable Electronic

In this section, refer to Figure 6 for the gas valve and Figure 7 for the remote control while doing the following lighting steps for the Variable Electronic burner system:

1. Verify that the Main Valve Knob is in the "OFF" position.
2. Verify that the Manual Knob is in the "ON" position.
3. Verify that the On/Off Switch is in the "I" (ON) position.
4. On the remote control, Hold the "ON/OFF" button down until you hear two beeps. This will automatically light the pilot and turn the Main Gas Knob to the "ON" position.
5. You should hear the spark ignitor attempting to light the pilot and before gas flows to the burner.
6. If the burner does not light after a maximum of 60 seconds **STOP!**, TURN OFF GAS SUPPLY and get assistance from qualified service personnel.
7. When pilot ignition is confirmed, the burner will be at maximum flame height.
8. Hold down the "-" sign (Flame Down Button) to decrease & the "+" sign (Flame Up Button) to increase the flame height.
9. Double-clicking "+" sets the flame to max height.
10. Double-clicking "-" sets the flame to min height.

11. Holding the "-" until the flame goes out leaves the pilot on and puts the burner in Standby Mode.
12. Hold the "ON/OFF" button down until you hear a single beep to turn the valve completely OFF.

In the event the remote control's transmitter or valve control receiver fails to operate, follow these steps to **light the fireplace manually**:

1. Make sure the Main Valve Knob (bottom knob) is fully clockwise  to the OFF position.
2. Make sure the Manual Knob is fully clockwise  to the "MAN" position.
3. Make sure the "On/ Off" Switch is in the "O" (OFF) position.
4. Verify that no gas is present around the fireplace or burner area (this could take 5 minutes to clear if present).
5. If you still detect gas **STOP!** Then follow the "WHAT TO DO IF YOU SMELL GAS" instructions found on the cover page of this manual.
6. Place On/Off Switch in the "I" (ON) position.
7. Using a pen or appropriate small tool, push the Manual Pilot Valve all the way in and hold. This starts the flow of gas to the pilot.
8. **Note:** When lighting the pilot, it may take as much as 30 seconds for gas to reach the pilot.
9. While still pushing the Manual Pilot Valve, push in the Piezo Ignitor to ignite the pilot.
10. Wait 10 seconds after the pilot is lit, then release the Manual Pilot Valve.
11. If the pilot does not stay lit when you release the Manual Pilot Valve, wait five (5) minutes and repeat the above steps.
12. Turn the Manual Knob counterclockwise  until it is in the "ON" position.
13. Turn the Main Valve Knob all the way counterclockwise  to the "ON" position.
14. If the burner does not light **STOP!**, TURN OFF GAS SUPPLY and get assistance from qualified service personnel.
15. Use the Main Valve Knob to adjust the flame to the desired height.

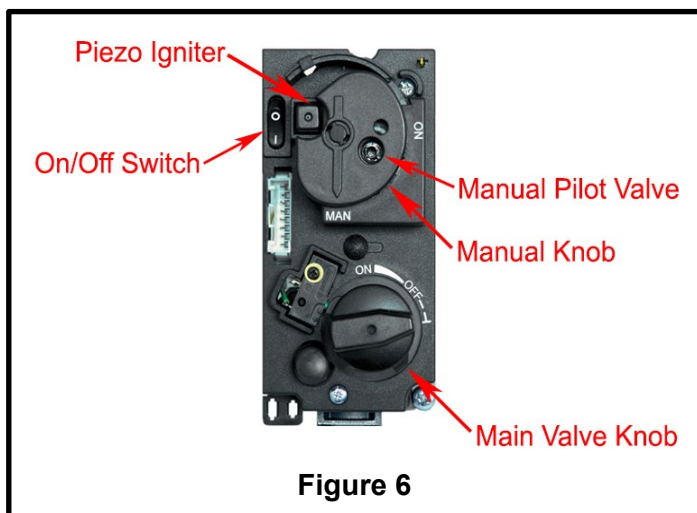

Figure 6

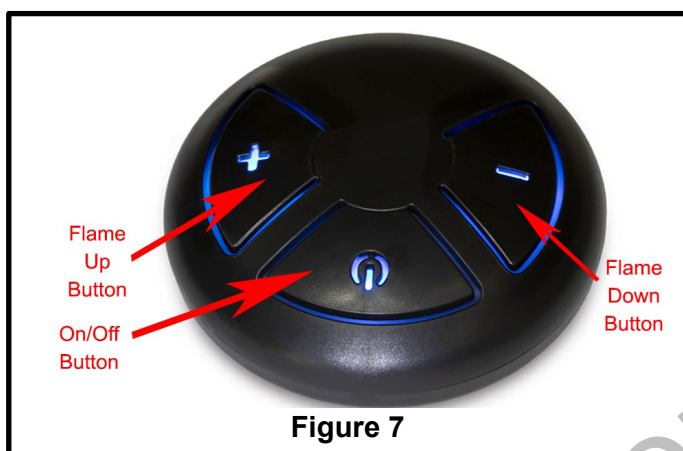

Figure 7

If you expect to not use the burner for an extended period of time, turn the Main Valve Knob to the “OFF” position, turn the Manual Knob to the “MAN” position, and turn the On/Off Switch to the “O” position. This will completely extinguish the ODS pilot and main burner. Then shut off the gas supply line valve to the fireplace.

➤ **Cleaning and Servicing**

It is imperative that you maintain your unvented gas appliance by having it cleaned and serviced regularly. A qualified professional service technician shall inspect and service this unit at least annually.

Failure to provide reasonable and necessary maintenance as outlined in the owner’s manual will cause your appliance to malfunction and will void your warranty.

If the flames show any unusual shapes or behavior, or the burner fails to ignite properly, then the burner holes may require cleaning.

WARNING: TURN OFF VENT FREE BURNER SYSTEM AND ALLOW TO COOL BEFORE CLEANING OR SERVICING.

✓ **Monthly Cleaning**

1. If removing logs, when reinstalling, refer to “LOG PARTS LIST” for correct log placement
2. Do not use cleaning fluids to clean logs or any part of the system.
3. Brush logs with a soft bristle brush or vacuum with brush attachment.
4. Vacuum loose particles and dust from the front and rear burners, gas controls, ignition control & grate.
5. Inspect and clean ODS pilot and accumulation of lint at burner ports.
6. Verify flame pattern and log placement for proper operation
7. Verify smooth and responsive ignition of main burner and rear burner

Pre-Installation Instructions

➤ General

BEFORE PROCEEDING, CAREFULLY READ ALL OF THE IMPORTANT SAFETY INFORMATION CONTAINED IN THIS OWNER'S MANUAL, INCLUDING:

- Pre-Installation and Fireplace Preparation Safety Guidelines
- Ventilation and Confined Space Information
- Installation Safety Guidelines

IMPORTANT

Be sure you have read and understand all safety precautions and warnings contained in this manual.

Read these instructions carefully and completely before starting installation of the burner system.

Installation and service must be performed by a qualified professional service technician, service agency or the gas supplier.

The Regency burner system must be installed by a qualified professional service technician. Instructions must be followed carefully to ensure proper performance and full benefit from the burner system. **Fireplace floor must be level, clean, and smooth.**

This appliance may be installed in an aftermarket, permanently located, manufactured (mobile) home where not prohibited by local codes.

This appliance is only for use with the type of gas indicated on the rating plate. This appliance is not convertible for use with other gasses.

➤ Pre-Installation Precautions & Safety

CAUTION: Installation and repairs must be done by an NFI certified or another qualified professional installer.

Installer: Carefully read these instructions before installing this gas burner system. Be sure you understand all safety precautions and warnings contained in this manual.

1. **CAUTION: If not installed, serviced, and used correctly per these instructions, this product can cause serious personal injury, property damage, or loss of life.**
2. Some fireplaces (especially older ones) may need repair prior to installing this appliance.
3. This appliance is only for use with the type of gas indicated on the rating plate. This appliance is **NOT CONVERTIBLE** for use with other gasses.
4. **CHECK GAS TYPE (Natural or L.P.):** the gas supply must be the same as stated on your burner system rating plate. If the gas supply is different, **DO NOT INSTALL.** Contact your dealer for immediate assistance.
5. **INSUFFICIENT GAS PRESSURE WILL KEEP THE ODS (OXYGEN DEPLETION SENSOR) PILOT FROM OPERATING PROPERLY. DO NOT USE IF GAS PRESSURE IS LOWER THAN THE MINIMUM REQUIREMENTS.**
6. The *minimum* inlet gas-supply pressure for the purpose of input adjustment is **5" water column (w.c.) on natural gas and 11" w.c. LP gas.**
7. The *maximum* inlet gas-supply pressure is **10.5" w.c. on natural gas and 13" w.c. LP gas.** The LP source must be regulated. **(Do not connect this appliance directly to an unregulated LP gas tank – this can cause an explosion.) Do not connect this appliance to a portable LP gas cylinder.**
8. **The gas piping system must be sized to provide minimum pressure at the maximum flow rate (BTU/Hr).** Undue pressure loss will occur if the pipe is too small, or the run is too long. Gas supply piping must be ½" minimum interior diameter. If the gas line is longer than 20', a larger diameter line may be necessary. Refer to the NFPA 54 guidelines for further details.
9. Input ratings shown in BTU per hour are for elevation up to 2,000 ft. For elevations above 2,000 ft., refer to the National Fuel Gas Code or contact Regency before installing.

➤ Burner System Requirements

Note: Installation in any other fireplace is prohibited and will void any approvals and warranties.

This burner system is equipped with an Oxygen Depletion Sensor (ODS) safety pilot system. The

ODS senses the amount of oxygen available in the room and shuts the burner system off before the oxygen level drops below 18%.

The pilot can only be relit when fresh air is available. This may require opening a window or a door to another room or cracking the damper open slightly.

This burner system has been certified to two standards:

VENTED DECORATIVE APPLIANCE – ANSI Z21.60

UNVENTED ROOM HEATER – ANSI Z21.11.2

➤ Vented Installation Restrictions

This unit may not be installed in a vented fireplace with a chimney of less than 15 feet in height.

This burner system may be installed as a vented decorative appliance in compliance with ANSI Z21.60 and the national Fuel Gas Code, Section 6.6. The minimum permanent free opening of the fireplace chimney or chimney damper must be met per the Chimney Vent Openings shown in Table 3.

To accomplish this, the chimney damper must be fixed in a manner to maintain permanent free opening at all times.

The damper clamp (See Figure 8) with bolt is provided as a means to prevent the full closure of the damper blade. The clamp is easily attached to most damper blades with pliers or a wrench, and must be permanently installed. The clamp is designed to prevent accidental closure of the damper when installed as pictured.

Should the clamp not fit, or fail to provide the required permanent vent opening, do any of the following:

- Have a permanent stop installed
- Remove the damper blade
- Install a screw or bolt on the edge of the damper
- Drill holes in the damper
- Cut the damper providing the minimum permanent opening required

This damper clamp is not required if the burner system is installed as an unvented room heater.

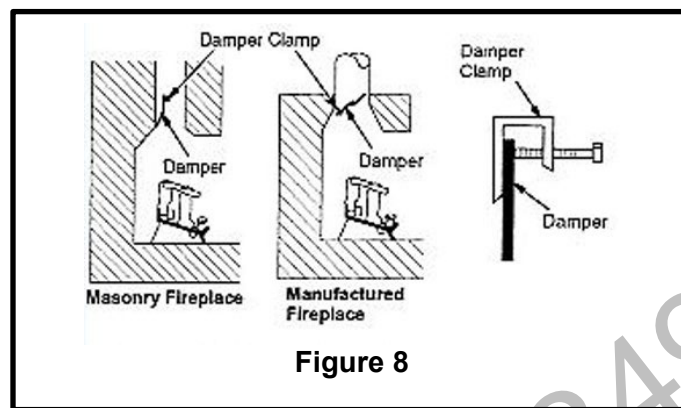

Figure 8

➤ Unvented Installation Restrictions

Note: To install the unvented gas burner system, the fireplace must have a gas-supply line that has been installed by a qualified professional service technician in accordance with all local codes.

Check local or state codes to determine if vent-free heaters are permitted in your locality before you install this burner system as a vent-free appliance. If not permitted, you may install and operate this burner system as a vented appliance.

When installed as an unvented decorative gas appliance, your vent-free gas burner system **SHALL NOT BE INSTALLED IN A CONFINED SPACE OR UNUSUALLY TIGHT CONSTRUCTION** unless provisions are made for adequate combustion and ventilation air.

Unusually tight construction is defined as:

1. Walls and ceiling exposed to the outside atmosphere have a continuous water vapor retarder with a rating of 1 perm or less with openings that are sealed or use gaskets;
2. Weather stripping has been added on openable windows and doors; AND
3. Caulking or sealants are applied to areas such as joints around window and door frames; between sole plates and floors; between wall-ceiling joints; between wall panels; at penetrations for plumbing, electrical and gas lines; and other openings.

✓ Determining a Confined Space

- In general, the National Fuel Gas Code, ANSI Z223.1/NFPA 54 defines a confined space as a space whose volume is less than 50 cu. Ft

per 1,000 BTU per hour of the aggregate input of all appliances installed in that space.

- An unconfined space is a space where the volume is at least 50 cu. Ft. per 1,000 BTU per hour of the aggregate input rating of all appliances installed in that space.
- Rooms communicating directly with space in which the appliances are installed, through openings not furnished with doors, are considered a part of the unconfined space.

WARNING: Do not install the unvented burner system where the room is considered a confined space.

To determine if the location that this burner system is to be installed fits the definition of an unconfined space, multiply in FEET the length of the room by the width of the room by the height of the room then multiply by 20. The result is the maximum BTU's allowed.

(Per Figure 9, calculate Length x Width x Height x 20 = Maximum BTU's Allowed)

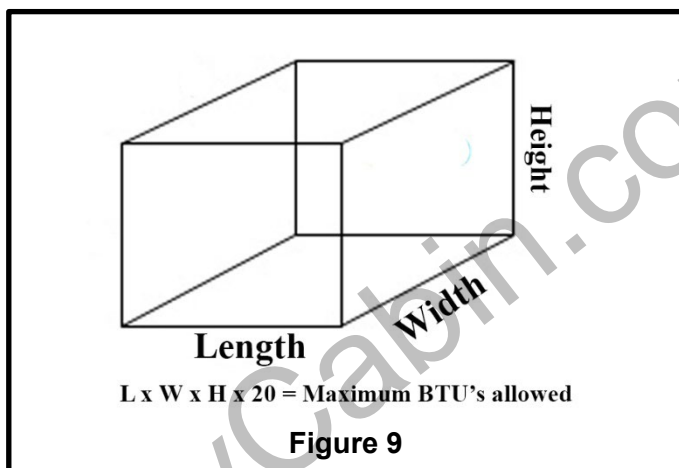

WARNING

If the area in which the heater may be operated is smaller than that defined as an unconfined space of if the building is unusually tight construction, provide adequate combustion and ventilation air by one of the methods described in the National Fuel Gas Code, ANSI Z223.1/NFPA 54, Air Combustion and Ventilation, or applicable local codes.

REMEMBER

L x W x H x 20 = MAXIMUM BTU's ALLOWED

BTU/H Rating High Setting

- 18" Burner Millivolt Variable/Electronic 35,000 Btu/h
NG
- 18" Burner Millivolt Variable/Electronic 32,000 Btu/h
LP
- 24" Burner Millivolt Variable/Electronic 37,000 Btu/h
NG
- 24" Burner Millivolt Variable/Electronic 37,000 Btu/h
LP

✓ **Installing in a Confined Space**

If the space is smaller than the above formula allows, and/or smaller than the diagrams, DO NOT install the vent-free burner system unless provisions for additional combustion and ventilation air are made.

IT MAY BE NECESSARY TO OPEN A WINDOW SLIGHTLY (1"-2") OR OTHERWISE INCREASE VENTILATION. CONDITIONS REQUIRING THIS INCLUDE, BUT ARE NOT LIMITED TO:

1. Installation in a **CONFINED SPACE**
2. Installation in a **HOME OF UNUSUALLY TIGHT CONSTRUCTION**
3. Installation at **HIGH ALTITUDES**
4. Certain **MEDICAL** or **PHYSICAL CONDITIONS OF THE HOMEOWNER** that may be adversely impacted by combustion products created by burning natural or propane gas.

Installation in a home with unusually tight construction and / or installation at high altitudes may cause your vent-free burner system to produce excessive heat or excessive moisture. The oxygen depletion sensor may shut down the burner system.

These conditions may be corrected by opening a window or otherwise increasing the number of air changes in the home.

This vent-free burner system has been certified to function safely and reliably with emission by-products well within acceptable safety and health standards.

Your specific medical or physical condition may render you more sensitive to products created by burning natural gas or propane gas. If this is the case, you should open a window or otherwise increase ventilation.

➤ Clearances to Combustibles

If the vent-free burner system is installed in a factory-built fireplace, follow the manufacturer's guidelines for minimum clearances to combustibles.

In the absence of such guidelines, refer to the illustration of clearances in Figure 10 and follow the instructions below:

Clearances to Combustible Construction:

Sidewalls: 6" from side of fireplace opening.

Ceiling: 42" from top of fireplace opening.

Flooring: See 5.6.1 CLEARANCE IN FRONT.

Mantel: See 5.6.2 CLEARANCE ABOVE.

Note: Clearances to combustible construction are those distances required to ensure that fireplace mantels, facings, walls, ceilings, and flooring will not catch fire.

In most cases, these clearances should also be adequate to prevent discoloration or warping due to heat. However, every gas burner installation presents a different and unique set of circumstances involving many variables beyond the control of the manufacturer.

These include paint or finish composition, previous exposures to heat, methods and quality of construction, air flow patterns, glass doors, fans or blowers, etc.

Because of these variables, we cannot guarantee that heat warping or discoloration will never occur. The potential for heat warping or discoloration may exist no matter what item(s) you are burning in the fireplace, including wood.

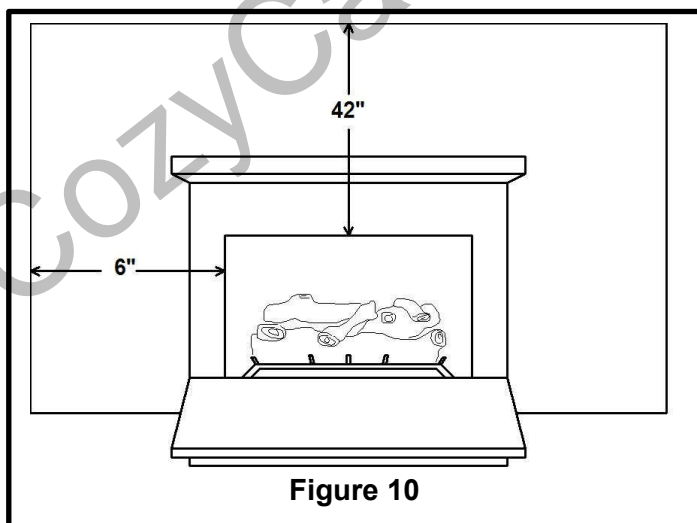

Figure 10

These dimensions are **MINIMUM CLEARANCES** to maintain when you install this burner system. The fireplace opening **MUST BE AT LEAST 6"** from any combustible sidewall. The ceiling **MUST BE AT LEAST 42"** from the top of the fireplace opening.

✓ Clearance IN FRONT

Be certain that combustible flooring material (i.e. carpet, tile, etc.) is not too close to the vent-free unit.

If the vent-free burner system is at floor level or less than 6" above the floor, there MUST be at least 12" (1 foot) of noncombustible material between the front of the fireplace and any combustible flooring.

✓ Clearance ABOVE

To install the vent-free burner system, there must **ALWAYS** be noncombustible or heat resistant material immediately above the fireplace opening. Heat resistant material (i.e. marble, or slate) must be at least 5/8" thick. Sheet metal should not be installed onto combustible materials.

If you **DO NOT** install a fireplace hood, there **MUST** be at least **12"** of noncombustible or heat resistant material immediately above the fireplace opening.

If you **DO** install a fireplace hood, there **MUST** be at least **10"** of noncombustible or heat resistant material immediately above the fireplace opening.

If there is a wooden mantel, shelf or other combustible projection above the fireplace, follow the clearances information in Figure 11 in this manual.

A fireplace hood deflects heat away from the fireplace face and mantel, reducing the potential for heat related warping or discoloration. The use of a fireplace hood is highly recommended.

DO NOT place any combustible decorations/items on the mantel or above the fireplace.

IF YOU CANNOT MEET THESE MINIMUM CLEARANCES, YOU MUST OPERATE THE VENT-FREE BURNER SYSTEM WITH THE CHIMNEY FLUE DAMPER OPEN.

➤ Fitting the Unit

✓ Location

This unit may be installed at any indoor location. However, when choosing a location, please keep in mind the following guidelines:

- Install out of direct sunlight for maximum performance.
- Select a suitable location that is not susceptible to moisture and is a safe distance from flammable items like drapes, furniture or high-traffic areas.

✓ Mounting Clearances

Observing minimum fireplace dimensions and centering the appliance in the fireplace will ensure adequate clearance for operation and servicing.

It may be necessary to disconnect the unit for some types of service in the future. Therefore, please keep this mind when arranging connections so that they have adequate clearances for easy access later.

✓ Optional Chimney Venting

Refer to Table 3 for chimney sizing requirements if the burner is to be installed as a vented appliance.

| Minimum Permanent Chimney Vent Opening In sq. in (when used as a vented appliance) | | |
|---|-----|-----|
| Factory built fireplaces – For masonry-built fireplaces, add 10 sq.in. to amount shown. | | |
| Chimney Height | 18" | 24" |
| 15' | 15 | 17 |
| 20' | 13 | 14 |
| 25' | 12 | 12 |
| 30' | 11 | 11 |

Table 3

✓ Product Installation Illustration

Refer to the product photo and installation illustration shown in Figure 12. A front view of the fireplace illustrated depicting the details of the measuring points for dimensions.

The illustration also shows the burner assembly as it appears when placed in a fireplace in a fully centered position.

These illustrations show how dimensions that are provided in this manual relate to the minimum size fireplace that must be used to install the gas logs.

✓ Product Dimensions

See Table 1 in the Introduction section at beginning of manual for the minimum size requirements for each model. Use this table to determine the fireplace dimensions necessary for the installation.

Mantel Clearances

IF YOU CANNOT MEET THESE MINIMUM CLEARANCES, YOU MUST OPERATE THE VENT-FREE GAS BURNER SYSTEM WITH THE CHIMNEY DAMPER OPEN

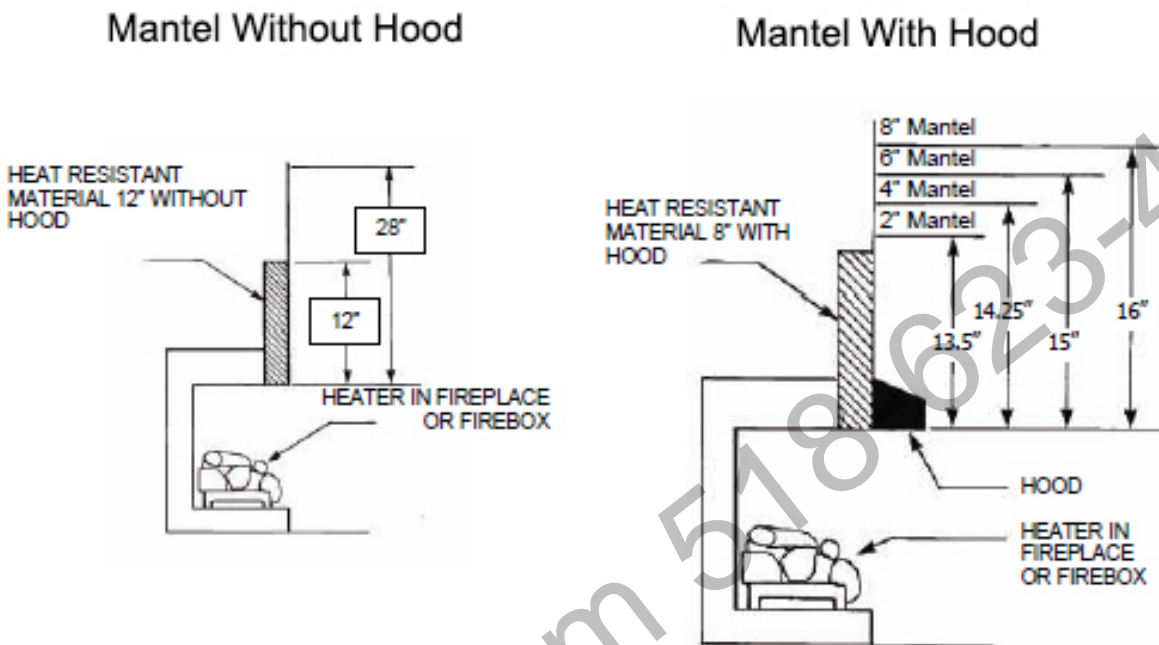

Figure 11

Fireplace Dimensions

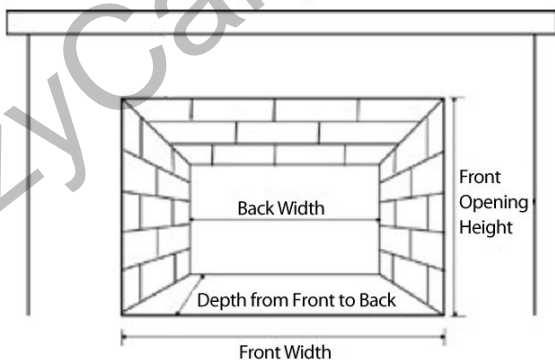

Figure 12

➤ **Preparation**

✓ **Unpacking**

Follow the procedure below to unpack and inspect the unit:

Carefully remove the packing from around the unit and set aside parts that are wrapped separately.

Check that all parts and accessories are accounted for before disposing of any packaging.

If necessary, keep the original packaging for future transport and/or storage.

Refer to Figures 13 & 14 to review the general contents of the packaging for the Millivolt Variable Control, and Variable Electronic models. Note that the appearance of the burner, gas valve, and remote control are different for each model.



✓ **Gas Connections**

WARNING:
Do not connect this appliance to a high-pressure natural gas line or unregulated propane tank.

CHECK GAS PRESSURE (natural or propane). The gas supply must be the same as stated on the burner system rating plate. **If the gas supply is different, DO NOT INSTALL.** Contact the dealer for immediate assistance.

Installation

WARNING: Failure to position internal parts in accordance with the installation diagrams or failure to use only parts specifically approved with this unvented burner system may result in property damage or personal injury.

➤ Installation Safety Information

1. Carefully inspect the burner and log cartons for shipping damages. If any parts are missing/damaged, call your dealer. **Do not attempt** to install the appliance unless all parts are in good condition.
2. Correct installation of the ceramic refractory log sets and proper placement and installation of the burner assembly, including ember placement and lava rock placement, are imperative to safe operation of your set. Problems **WILL** occur if all items are not properly installed. Reference the **INSTALLATION** section, **LOG PLACEMENT**.
3. When installing in a wood-burning fireplace, center the appliance in the fireplace while making certain that no part of the assembly protrudes (forward) beyond the fireplace face. **DO NOT PUSH THE UNIT ALL THE WAY TO THE BACK.**
4. If you use lava rock or glass, for decorative use, do not allow these accessories into or onto any part of the burner or logs. Lava rock or glass used to accessorize the vent-free burner, should only be placed on the floor of the fireplace, in front of and to the sides of the burner, but away from the controls.
5. **DO NOT PLACE** logs or accessories, such as vermiculite, glass or other foreign items on this appliance. These items will cause improper burning, sooting, and/or high levels of carbon monoxide. Additional logs and/or accessories may be placed around the burner system, as long as they do not interfere with the burning of the gas appliance.
6. Connecting directly to an unregulated LP tank can cause an explosion.

7. Special care is required if you are installing the unit into a **SUNKEN FIREPLACE**. You must raise the fireplace floor to allow access to gas controls. This will ensure adequate airflow and guard against sooting. Raise the fireplace floor using noncombustible materials.

✓ Fireplace Floor Requirements

DO NOT install this burner system if the fireplace hearth is recessed. The fireplace floor must be at the same level as or larger than the fireplace front opening. An ash lip or recess may not exceed $\frac{3}{4}$ ". See Figure 15 below.

Note: If glass doors are used, the fireplace floor must not be blocked by the door frame; the frame must have openings to allow for fresh air circulation during combustion.

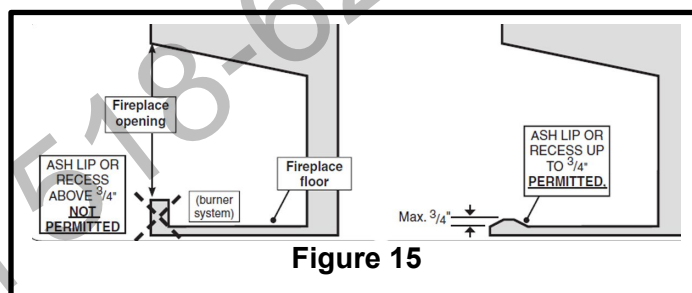

Figure 15

✓ Installing the Burner Unit

REFER TO THE PARTS LIST WHEN FOLLOWING THESE INSTRUCTIONS. The 18/24" burner models are shown in the illustrations.

INSTALL BURNER:

GAS CONNECTION WARNING: Only persons licensed to work with gas piping may make the necessary gas connections to this appliance. Since some municipalities have additional local codes, it is always best to consult with your local authorities and the CSA B149.1 installation code. For U.S.A. installations, follow local codes and/or the current National Fuel Gas Code, ANSI Z223.1 for approved fittings with copper or flex connectors. Always provide a union so that gas lines can be easily disconnected for servicing. Flare nuts for copper lines and flex connectors usually meet this requirement. A separate gas shut-off valve should be installed immediately upstream of the connection to the appliance.

Bring gas line gas to appliance. Ensure the gas line is properly sized for the BTU. This must be completed prior to installation of burner.

If the factory-built fireplace/masonry fireplace has no gas access hole(s) provided, an access hole of 1.5 inch (37.5 mm) or less may be drilled through the lower sides or bottom of the firebox in a proper workmanship-like manner. This access hole must be plugged with non-combustible insulation after the gas supply line has been installed.

1. MAKE SURE THE FIREPLACE GAS SUPPLY IS TURNED OFF.
2. Locate the gas-supply stub inside the fireplace and remove the cap, if attached.
3. **CAUTION:** When removing the cap, make sure the stub does not turn, loosening the connection in the wall.
4. **Be sure gas to the fireplace is turned off.** On the burner, remove the adapter that has been loosely screwed into the end of the flex connector (pre-installed on the burner system). Attach the adapter to the gas-supply stub using a pipe compound resistant to all gasses. Tighten securely.
5. In Figure 16, the gas supply stub is shown properly fitted with the adapter.



Figure 16 – Shown in a factory-built fireplace

6. Place the burner system in the fireplace. Centering the burner front to back & side to side as shown in Figure 17.

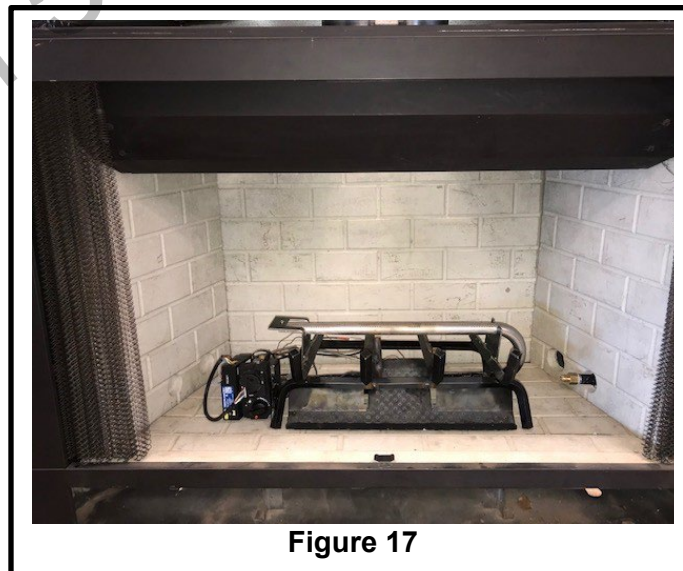

Figure 17

7. Attach the flex connector to the adapter as shown in Figure 18. Tighten securely. IF FLEX LINE IS NOT LONG ENOUGH, LONGER FLEX LINES CAN BE PURCHASED AT YOUR LOCAL HARDWARE STORE.

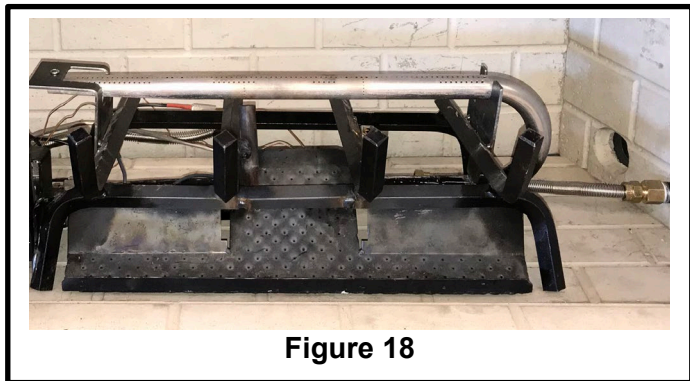

Figure 18

8. LEAK TEST: Turn on the fireplace gas supply, and test at all connections for leaks using the appropriate soapy water solutions. If bubbles appear, turn off the gas supply and re-tighten all the connections.
9. Repeat testing & tightening until no leaks are present. If the leak still remains, turn off the gas supply and contact the local gas company or dealer. NEVER USE A FLAME TO CHECK FOR LEAKS.

✓ **Installing the Remote Control**

IMPORTANT: The remote receiver should be kept away from the burner as far as possible within the cavity (left or right side) to minimize temperatures. Before installation make sure the remote receiver slide switch is in the OFF position.

Depending on which model you have, you will use one of the 2 types of remote controls available. Pick the appropriate instructions for your model below and follow them carefully.

NOTE: The setup for the remote control is a one-time setting and is not required again, even after a building power failure or changing the transmitter or receiver batteries. However, these steps would need to be repeated if the actual transmitter, receiver, or both are ever replaced.

Use the type of batteries included with the kit for installation. Always observe polarity when installing batteries. It is recommended that the original type of batteries always be used for longer life and optimum performance.

1...1 Installing the Millivolt Variable Remote

Connect the 2 black/red wires from the remote receiver (found in the white box) to the gas valve. See picture for correct orientation of 2 wires. Red wire connected to left hand side and black wire connected to right hand side of gas valve. See figure 18a.



Figure 18a

Install the included AA alkaline batteries in the transmitter by first sliding out the battery compartment cover. Then, insert the batteries in the battery compartment, while observing polarity, and slide it closed as shown in Figure 19.

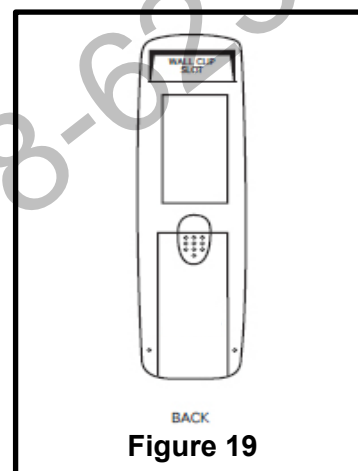

Figure 19

Open the cover for the remote receiver, and insert the 4 included alkaline AA batteries by sliding open the battery cover, inserting the batteries, and sliding the cover closed. See figure 20.

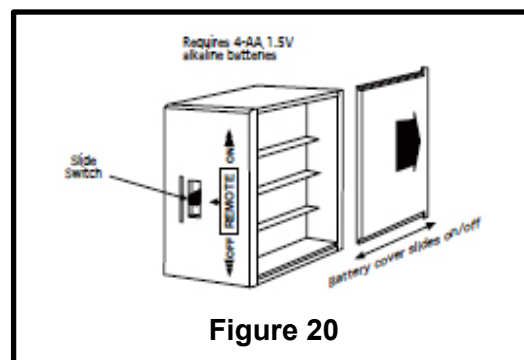

Figure 20

To set the electronic code that is used to synchronize the receiver and transmitter, please follow these steps:

1. Slide the function button on the receiver to the REMOTE position (Figure 21).

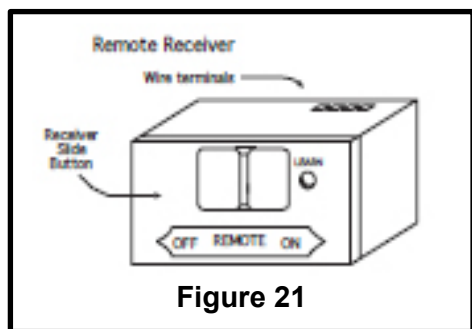

Figure 21

2. Locate the LEARN button located on the front right face of the receiver inside the small hole labeled LEARN. Then, using a small screwdriver (or end of a paperclip), gently press the LEARN button positioned inside, and release.
3. The receiver will emit a “beep”.
4. After the receiver emits the beep, press the transmitter’s OFF button, then release. The receiver will emit several beeps indicating that the transmitter’s code has been accepted and saved by the receiver.
5. Move the slide button to the “REMOTE” position and place the receiver in front corner of the fireplace as far from the burner as possible.

Proceed to the next section for burner testing.

1...2 *Installing the Variable Electronic Ignition Remote*

Install the included 2 AAA batteries in the “Puck” transmitter by first removing the battery compartment cover. Then, insert the batteries in the battery compartment and close it (Figure 24).

The remote control receiver is located on the left side the burner unit. To install the batteries, open the cover and install the included 4 AA batteries (Figure 22). Replace the cover.

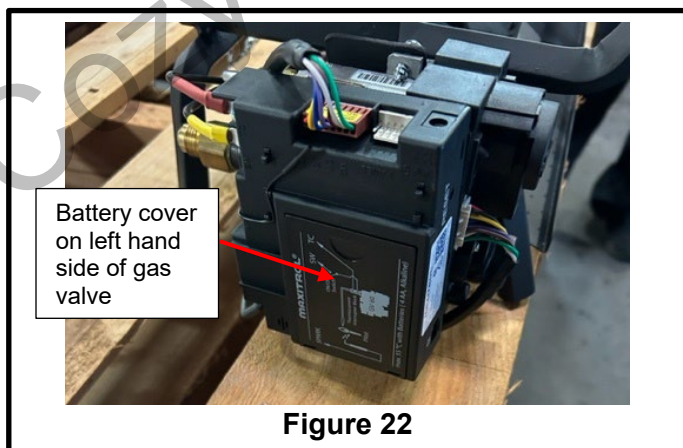

Figure 22

The pair is now ready to synchronize.

To set the electronic code that is used to synchronize the receiver and remote control, please follow these steps:

1. Locate the RESET button located on the top of the front face of the receiver inside the small hole labeled RESET (Figure 23). Then, using a small screwdriver (or end of a paperclip), gently press the RESET button positioned inside, and hold.

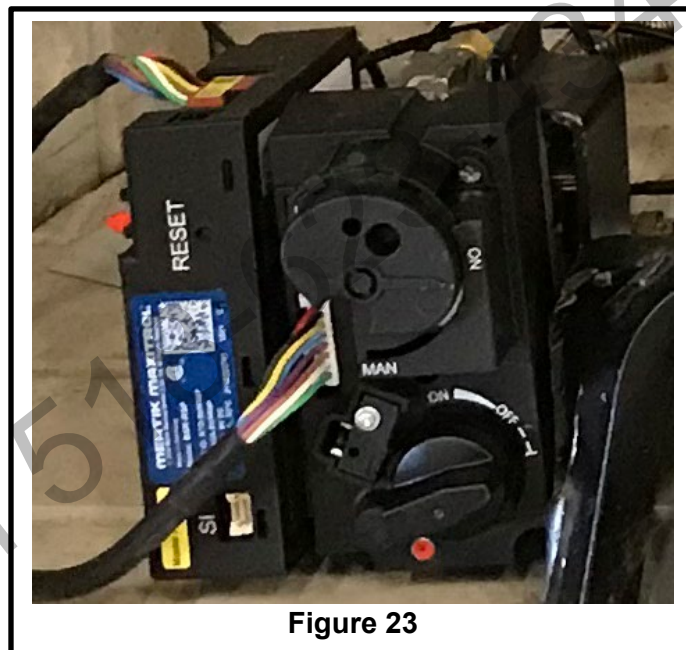

Figure 23

2. After the long beep, release the reset button.
3. Within the next 20 seconds, press the transmitter’s flame down button (Figure 24) until you hear the receiver emit two short beeps confirming that the code has been set.

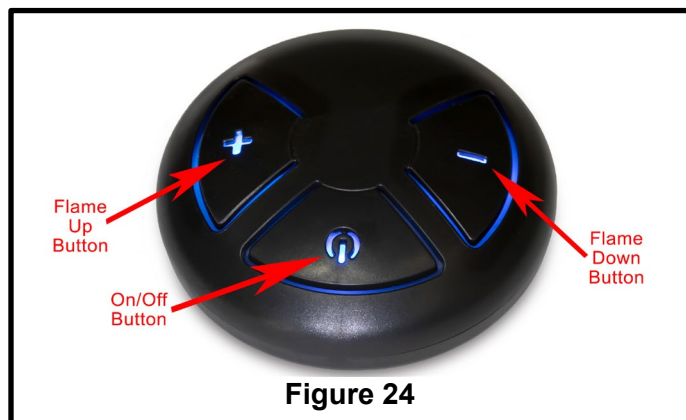

Figure 24

4. If you hear one long beep, this indicates that the code learning sequence has failed or the wiring is incorrect; please try again and check the wiring connections on the control.

✓ Setting the Controls

It is recommended that before you install the decorative media, you familiarize yourself with the control valve layout and light the burner to test. This review will assist you when operating the burner system.

IMPORTANT: For all valves, the air **MUST** be purged from the gas line before the pilot will light and burn properly. The time needed to purge will depend on the length of the gas line to the unit and the amount of time since the unit and gas line was used last.

It may take several minutes before all the air is purged and the pilot will light and burn properly. Reference the LIGHTING INSTRUCTIONS in the User section of this manual for details when you are ready to light the burner.

✓ Checking the Gas Pressure

AT THIS STAGE, FOLLOW THE INSTRUCTIONS BELOW TO ASSURE THAT THE GAS PRESSURE IS CORRECT.

The burner system and its main gas valve must be disconnected for the gas-supply piping system during any pressure testing of that system at test pressures in excess of ½ psi (3.5 kPa).

The burner system must be isolated from the gas-supply piping system by closing its equipment shutoff valve during any pressure testing of the gas-supply piping system at test pressure equal to or less than ½ psi (3.5 kPa). This is accomplished by closing the gas supply line valve.

IMPORTANT: Check the operating gas pressure with the system burning and the control fully **ON**. See **Table 2** for Natural Gas and Propane Gas pressure information.

MILLIVOLT VARIABLE and VARIABLE ELECTRONIC CONTROL VALVES

Check the valve regulator pressure at the Inlet Pressure Tap location referenced in Figure 25. Using a small screwdriver angled up & under the bottom right side of the valve, turn the inlet *screw* counterclockwise 2 or 3 turns, then place the pressure gauge tubing over the Inlet Pressure Tap.

After taking the pressure reading, remove the tubing, and turn the inlet screw clockwise until seated. Do not over-torque. Check for gas leaks.



Figure 25

✓ Placing Decorative Media

NOTE: Loose material shall be installed per these Instructions. Replacement loose material must be purchased directly from Regency or a factory-authorized dealer.

Application of excess loose material may adversely affect performance of the heater.

WARNING: ALL PREVIOUSLY APPLIED LOOSE MATERIAL MUST BE REMOVED PRIOR TO REAPPLICATION.

Generally, decorative media is installed in the ember bed below and in front of the burner to achieve the desired glowing effect when the burner is lit.

This media must be close enough to the ember bed flame feed holes to get hot enough to appear as live coals. If the media needs to be repositioned after lighting, allow enough time (at least 10 minutes) for it to cool before making any changes.

1...1 *Placing Glowing Embers*

Glowing embers should be placed first in the ember bed in the center of the pan below the burner. Evenly distributed so as to cover all the holes in the center of the bed.

1...2 *Placing Lava Rock*

Next, place the lava rock evenly along front edge of the ember bed and out to the front edge of the fireplace. Be sure not to place it in the way of doors, screens, or other items needed to operate the fireplace.

1...3 *Making the Media Consistent*

There should be no gaps between the lava rock and the glowing embers (Figure 26). Make sure that placement is done to avoid clumping while keeping the media components butted together. This is necessary to give the coals a consistent appearance when lit. Save any unused media for possible use later.

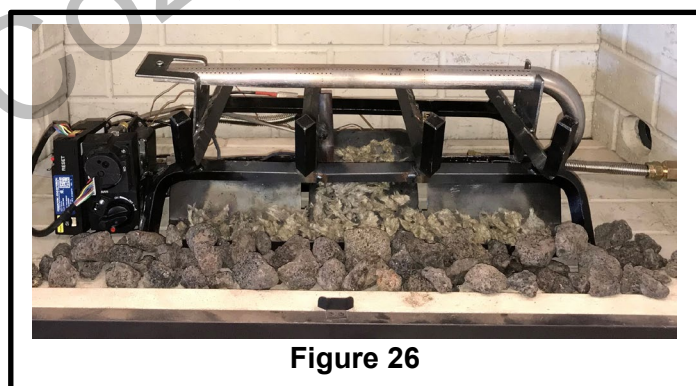

Figure 26

✓ Log Set Placement

You must position and maintain the appropriate log layout to ensure optimal operation of the burner system. The 18" & 24" sizes use the same log styles with varied paint schemes. Design may vary slightly; placement is the same.

CAUTION: BURN HAZARD! Logs will remain hot for some time after use. If you need to reposition any log to maintain the proper layout, use heat-resistant gloves or allow logs adequate time to cool before handling.

For all log sizes, the undersides of the bottom logs have cutouts and tabs that align over the burner. **THE BOTTOM LOGS MUST BE FULLY SEATED FLAT ON THE BURNER.** Certain logs have notches on them to allow the logs to interlock in place with other logs.

Log placement is illustrated below using a dark border around the particular logs that are being placed in each step.

Gas Maintenance

In order for your Regency appliance to continue to provide comfort to your home, periodic maintenance must be performed to ensure it is operating at peak efficiency. The items in the list should be checked by a licensed gas service technician during the annual service check. Your unit may require more frequent maintenance checks if you notice any changes in how it operates. Operational changes to look for can include, but are not limited to, extended start up time, residue/carbon build up, etc. Should any of these or other conditions arise, discontinue use and schedule a service check with your local licensed gas technician. The list below shows items your licensed service technician will need to check and service at least annually.

CLEAN

- Burner ports & burner air shutter
- Log set
- Pilot orifices
- Pilot hood (Vented)
- Flame sensor (electronic ignition models)
- Flame electrode
- Burner orifice
- Thermocouple (Vent free model)
- Thermopile (millivolt models)

INSPECT

- Pilot assembly
- Burner
- Firebox
- Venting
- Batteries (remote handheld, remote receiver, ignition module, change as needed)
- Burner media (change as needed)
- Air shutter setting (Vent free model)
- Wiring

CHECK

- Voltage on thermopile (millivolt vented models)
- Ohms reading on flame sense (electronic ignition vented models)
- Inlet/outlet fuel pressures as per rating plate
- Voltage/ohms readings on gas valve

- Voltage on thermocouple (Vent free)
 - Ensure pilot is fully engulfing the thermopile and flame sensor (Millivolt/electronic Ignition vented)
 - Ensure pilot is fully engulfing thermocouple (Vent free only)

GAS LEAK TESTS

- Check main gas line connection to valve
- Check shut off valve connections
- Check connection at gas valve outlet
- Check connection at main burner orifice
- Check pilot fuel line at valve and at pilot assembly

Troubleshooting

- Only a qualified professional service person should service and repair this appliance.
- Turn off unit and allow to cool before troubleshooting.

Burner Shutting Down During Operation

| Possible Cause | Solutions |
|--|---|
| <ul style="list-style-type: none"> • Insufficient or excessive gas pressure | <ul style="list-style-type: none"> • Check Inlet/Outlet Gas pressure. Check with local gas company. • Other gas appliances may be on the same gas line, dropping gas pressure to the burner system when other appliances are in operation. Check pressure with everything operating to ensure adequate pressure. |
| <ul style="list-style-type: none"> • Debris in or around the fireplace and the air intakes of the IDS pilot | <ul style="list-style-type: none"> • Dust, carpet fibers, paper, spider webs, pet hair, etc. in the fireplace or on burner assembly can affect the operation of the burner and ODS pilot assembly. Clean out debris and vacuum around burner. Vacuum or use compressed air to clean out the ODS pilot assembly area, air shutter, burner orifice and ODS pilot intake openings. Blockage in this area will affect the operation of the ODS pilot assembly. |
| <ul style="list-style-type: none"> • Room size (Unconfined Space) | <ul style="list-style-type: none"> • 50 Cu ft is required for every 1,000 BTU. Multiply the rooms length x width x height by 20 (L X WX H x 20) If resulting number is less than the BTU rating of the burner, ODS pilot outages may occur. Provisions for adequate combustion and ventilation air must be made |
| <ul style="list-style-type: none"> • Flue area, fireplace, or damper dirty from soot. | <ul style="list-style-type: none"> • Clean around, above and under the damper thoroughly. Clean fireplace, remove loose material including soot and creosote. |
| <ul style="list-style-type: none"> • Fans, furnaces, air conditioning vents, blowing into the fireplace may cause drafts altering flame patterns. | <ul style="list-style-type: none"> • Eliminate the drafts by closing heating and air conditioning vents and closing outside air vents. Fans blowing directly into the fireplace should be turned off when appliance is operating. |
| <ul style="list-style-type: none"> • Blockages on burner | <ul style="list-style-type: none"> • Clean up any media or material that may have fallen onto burner port area. |
| <ul style="list-style-type: none"> • Fireplaces with high top cavities can accumulate by-products of combustion | <ul style="list-style-type: none"> • Open a nearby window or damper slightly. Move burner forward if possible. |

Troubleshooting

| | |
|---|---|
| <ul style="list-style-type: none"> Inadequate air circulation | <ul style="list-style-type: none"> Check log placement, media placement and sizing of burner system. (Refer to manual for correct placement and requirements) Position burner closer to the front of the fireplace. (NOTE: Do not place burner too close to combustibles) Check for sunken fireplace, excessive media or other accessories packed to tightly against the burner or high bottom lip on glass door. Open a nearby window or damper slightly. |
| <ul style="list-style-type: none"> Fireplace too small for appliance. | <ul style="list-style-type: none"> Ensure the minimum requirements are met. |
| <ul style="list-style-type: none"> High altitude or too much heat or moisture can cause ODS pilot to shut down system. | <ul style="list-style-type: none"> Confirm minimum requirements are met. |
| <ul style="list-style-type: none"> ODS pilot flame lifting off thermocouple | <ul style="list-style-type: none"> Check gas pressure. |
| <ul style="list-style-type: none"> Pilot (Remote capable) | <ul style="list-style-type: none"> Contact your local Regency dealer for instructions on replacement. |
| <ul style="list-style-type: none"> Log Placement | <ul style="list-style-type: none"> Reference the log set placement section in this owner's manual for recommended log placement. |

ODS Pilot will Not Light.

| | |
|--|--|
| <ul style="list-style-type: none"> ODS pilot flame lifting off thermocouple. | <ul style="list-style-type: none"> Check gas pressure |
| <ul style="list-style-type: none"> Piezo spark not lighting ODS pilot. | <ul style="list-style-type: none"> Check to make sure Piezo is sparking when pressing or turning igniter. You may need to press and turn igniter several times to ignite ODS pilot. |
| <ul style="list-style-type: none"> Electrode wire loose. | <ul style="list-style-type: none"> Check wiring and reconnect any loose wiring. |
| <ul style="list-style-type: none"> Igniter electrode positioned incorrectly | <ul style="list-style-type: none"> Contact your local Regency dealer for Service. |
| <ul style="list-style-type: none"> Gas supply off/manual shut off valve closed. | <ul style="list-style-type: none"> Turn on gas supply or open manual shut off valve. |
| <ul style="list-style-type: none"> Air in gas line | <ul style="list-style-type: none"> Hold control knob to bleed the gas line and repeat until air is removed from line. |
| <ul style="list-style-type: none"> Pilot hood blocked | <ul style="list-style-type: none"> Check for debris or dirt and clean pilot |
| <ul style="list-style-type: none"> Dead batteries (If applicable) | <ul style="list-style-type: none"> Replace batteries as needed. |

High CO- Carbon Monoxide Detectors in home turning alarm On.

| | |
|--|---|
| <ul style="list-style-type: none"> High CO levels | <ul style="list-style-type: none"> Turn off unit immediately, open windows and doors to get oxygen circulating in the area the appliance is installed in. Call your local Regency Dealer or a qualified service technician or local gas supplier. |
|--|---|

Troubleshooting

Condensation

- | | |
|--|--|
| <ul style="list-style-type: none"> high room humidity and uninsulated cold walls or windows will create condensation in room. | <ul style="list-style-type: none"> Open a nearby window or damper slightly. |
|--|--|

Low Flame Height

- | | |
|---|---|
| <ul style="list-style-type: none"> Low gas pressure | <ul style="list-style-type: none"> Check gas pressure, check rating plate for correct pressure readings. |
| <ul style="list-style-type: none"> Household propane tank running low | <ul style="list-style-type: none"> Fill tank completely |
| <ul style="list-style-type: none"> Supply valve not fully open | <ul style="list-style-type: none"> open supply valve fully, if valve cannot open fully call your local Regency dealer or Qualified gas installer. |
| <ul style="list-style-type: none"> Blockage or kink in the flex connector kit, gas supply line or burner office. | <ul style="list-style-type: none"> Clean out blockage if flex connector is kinked replace it. Or contact your local Qualified gas installer or Regency Dealer. |
| <ul style="list-style-type: none"> Remote set on low flame (If applicable) | <ul style="list-style-type: none"> Adjust flame with remote transmitter, if buttons do not adjust the flame height, contact your local Regency dealer. |

Burner Not Burning Evenly

- | | |
|--|---|
| <ul style="list-style-type: none"> Burner ports clogged | <ul style="list-style-type: none"> Clean burner ports |
| <ul style="list-style-type: none"> Burner has delayed ignition or does not light. | <ul style="list-style-type: none"> Check gas pressure, can be caused by under sized gas line. Ensure pilot comes into contact with burner Check for obstructions around pilot Low propane fuel gas level, Vacuum burner tube for soot blockage and fill propane tank. Air shutter blocked. Clear blockage. |

Smell

- | | |
|---|---|
| <ul style="list-style-type: none"> New Burner system (Break in period) | <ul style="list-style-type: none"> Clean burner ports |
| <ul style="list-style-type: none"> Odors created by aerosol sprays, detergents, household chemicals, insecticides, new home, new carpet, or new paint. | <ul style="list-style-type: none"> When these odors are drawn into the fireplace, this may cause unpleasant odors, thoroughly ventilate the area before restarting your appliance. |
| <ul style="list-style-type: none"> Gas Leak | <ul style="list-style-type: none"> Shut off gas immediately & have a qualified Gas service technician, or the gas company check for all leaks. |

Troubleshooting

Carboning

| | |
|---|---|
| <ul style="list-style-type: none"> Low Gas pressure | <ul style="list-style-type: none"> Check Gas pressure refer to rating plate for correct gas pressure readings |
| <ul style="list-style-type: none"> Drafts in room | <ul style="list-style-type: none"> Eliminate drafts by closing heating and air conditioning vents, and outside vents. Fans blowing into fireplace should be turned off when the appliance is in operation. |
| <ul style="list-style-type: none"> Air shutter blocked | <ul style="list-style-type: none"> Burner air shutter are blocked with debris, vacuum out debris in and around the burner area. |
| <ul style="list-style-type: none"> Using a product other than Regency Gas logs with Burner. | <ul style="list-style-type: none"> Make sure only Regency Vent free gas logs are used with our vent free burner. |
| <ul style="list-style-type: none"> Using Natural gas burner on propane gas or propane burner on natural gas. | <ul style="list-style-type: none"> If gas listed on nameplate does not match gas you are burning, shut down burner system immediately and call your local Regency dealer. These are not field convertible. |
| <ul style="list-style-type: none"> Adding any accessories to burner system | <ul style="list-style-type: none"> shut down burner system and take off any accessories that do not belong with the appliance. |
| <ul style="list-style-type: none"> Blocked Orifices(s) | <ul style="list-style-type: none"> Dust, lint, fibers, paper, spider webs, pet hair, etc. in the fireplace and on the burner, assembly can affect the operation of the burner and the ODS pilot assembly. Clean out the debris and vacuum around the burner for dust that may have accumulated over time. Vacuum the ODS pilot assembly and over the air shutter holes, any blockage in this area will affect the operation of the ODS sensor. |
| <ul style="list-style-type: none"> Improper media placement | <ul style="list-style-type: none"> See manual for correct media placement. |
| <ul style="list-style-type: none"> Log Placement | <ul style="list-style-type: none"> See manual for Log set placement. |

ODS Pilot Will Not Stay Lit.

| | |
|--|---|
| <ul style="list-style-type: none"> Have not pressed and held knob in long enough. (If applicable) | <ul style="list-style-type: none"> Hold down knob for 1 minute then release. If the knob does not hold, contact your local Regency Dealer for service. |
| <ul style="list-style-type: none"> Valve will not hold. | <ul style="list-style-type: none"> Contact your local Regency Dealer. |
| <ul style="list-style-type: none"> Pilot line bent/ Kinked | <ul style="list-style-type: none"> Replace pilot Line. |
| <ul style="list-style-type: none"> Thermocouple is loose. | <ul style="list-style-type: none"> Tighten thermocouple nut as the gas valve (Do not over tighten) |
| <ul style="list-style-type: none"> Thermocouple is cracked or work out. | <ul style="list-style-type: none"> Replace thermocouple |

Whistling Noise Coming From Burner

| | |
|--|---|
| <ul style="list-style-type: none"> Burner may be cold or may have not been used for an extended period. | <ul style="list-style-type: none"> Allow burner to warm up on low. |
|--|---|

Troubleshooting

| | |
|--|--|
| <ul style="list-style-type: none"> Air in gas line | <ul style="list-style-type: none"> Hold control knob to bleed the gas line and repeat until air is removed from line. |
| <ul style="list-style-type: none"> Clogged air openings | <ul style="list-style-type: none"> Clean all air openings |

Burner Will Not Turn On

| | |
|---|--|
| <ul style="list-style-type: none"> Low/ Dead Batteries (if applicable) | <ul style="list-style-type: none"> Replace batteries when needed. |
|---|--|

Flame At Air Mix/ Orifice (Propane Models)

| | |
|--|---|
| <ul style="list-style-type: none"> Burner Ports clogged | <ul style="list-style-type: none"> Clean burner ports |
| <ul style="list-style-type: none"> Gas pressure | <ul style="list-style-type: none"> Check gas pressure, see rating plate. |

Popping Noise Coming From Burner

| | |
|---|--|
| <ul style="list-style-type: none"> Air shutter Blocked | <ul style="list-style-type: none"> Clear air shutter of all Obstructions. |
|---|--|

CozyCabin.com 518-623-4349



OAK 18" LOG PLACEMENT GUIDE VENT FREE LOGS PART # 946-832

003-150



003-151

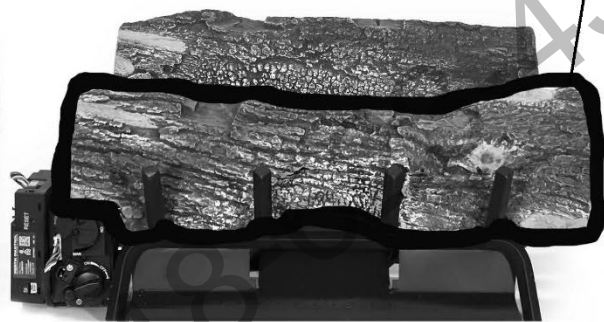

003-153

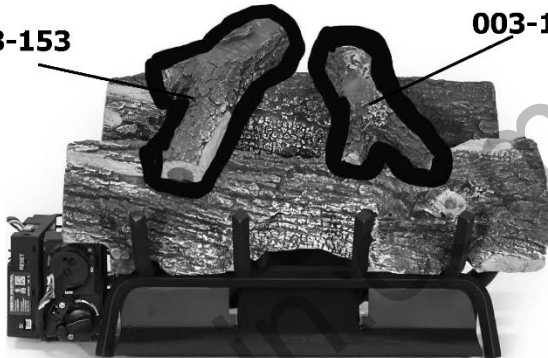

003-154



003-155

003-156

003-157



Checking the Log Placement

After setting the logs from the appropriate log kit into position as described above, ensure each is properly and firmly seated flat in the grooves or notches.

A vent-free gas log set will not function as intended if the logs are not correctly positioned. When placed properly, the flames will not strike any portion of the logs.

Failure to properly place the logs will cause sooting and improper Carbon Monoxide output.

Periodically check the positioning of all logs to ensure proper log placement and stability. If any flame is striking the logs, recheck log placement. Adjust to conform with instructions. There should be no flame impingement on the logs.

Log placement should be re-checked as part of the fireplace maintenance procedure. Logs may not remain in their original position over time.



OAK 24" LOG PLACEMENT GUIDE VENT FREE LOGS PART # 946-833



Checking the Log Placement

After setting the logs from the appropriate log kit into position as described above, ensure each is properly and firmly seated flat in the grooves or notches.

A vent-free gas log set will not function as intended if the logs are not correctly positioned. When placed properly, the flames will not strike any portion of the logs.

Failure to properly place the logs will cause sooting and improper Carbon Monoxide output.

Periodically check the positioning of all logs to ensure proper log placement and stability. If any flame is striking the logs, recheck log placement. Adjust to conform with instructions. There should be no flame impingement on the logs.

Log placement should be re-checked as part of the fireplace maintenance procedure. Logs may not remain in their original position over time.



BIRCH 18" LOG PLACEMENT GUIDE VENT FREE LOGS PART # 946-834

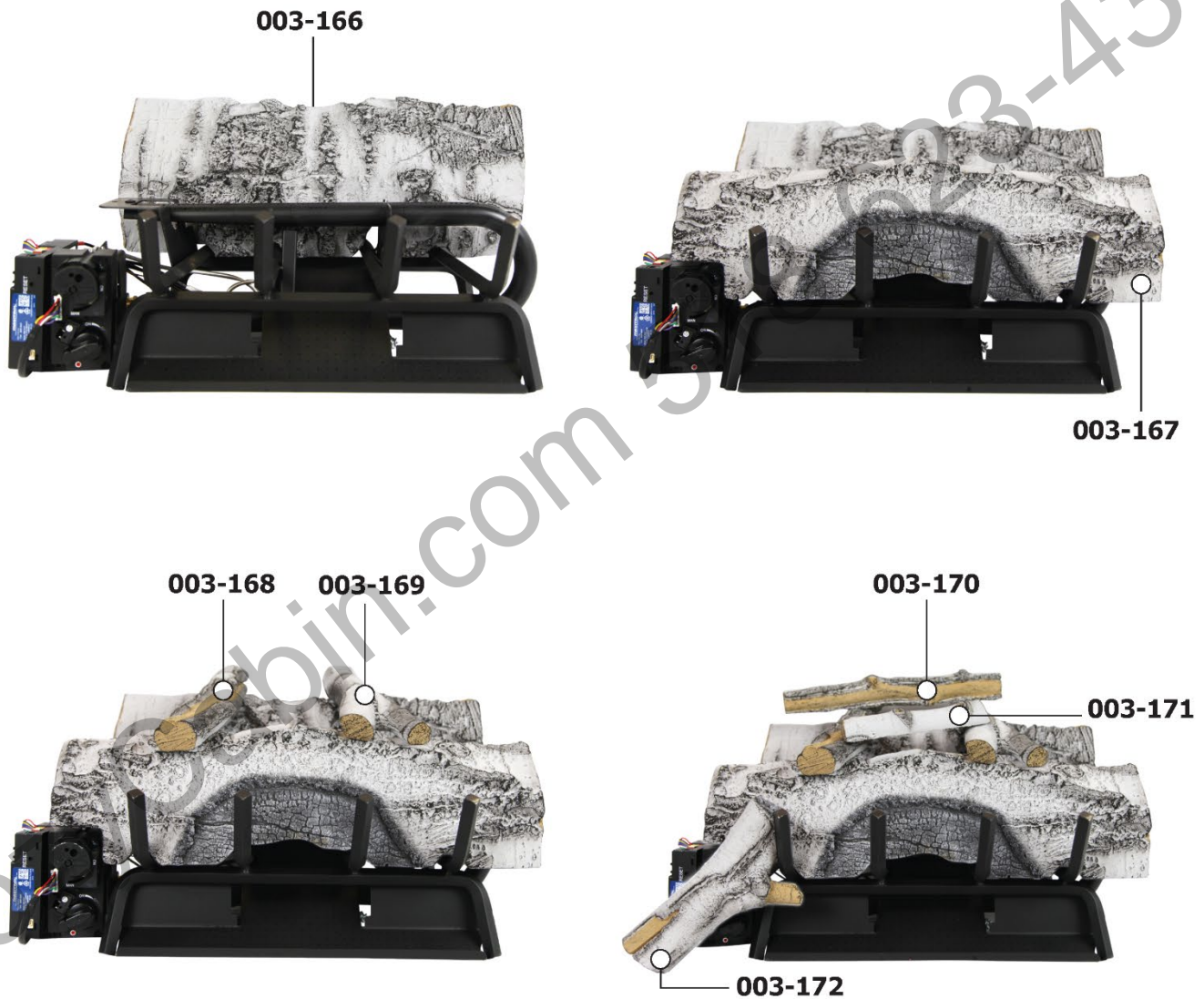

Checking the Log Placement

After setting the logs from the appropriate log kit into position as described above, ensure each is properly and firmly seated flat in the grooves or notches.

A vent-free gas log set will not function as intended if the logs are not correctly positioned. When placed properly, the flames will not strike any portion of the logs.

Failure to properly place the logs will cause sooting and improper Carbon Monoxide output.

Periodically check the positioning of all logs to ensure proper log placement and stability. If any flame is striking the logs, recheck log placement. Adjust to conform with instructions. There should be no flame impingement on the logs.

Log placement should be re-checked as part of the fireplace maintenance procedure. Logs may not remain in their original position over time.



BIRCH 24" LOG PLACEMENT GUIDE

VENT FREE LOGS PARTS # 946-835



Checking the Log Placement

After setting the logs from the appropriate log kit into position as described above, ensure each is properly and firmly seated flat in the grooves or notches.

A vent-free gas log set will not function as intended if the logs are not correctly positioned. When placed properly, the flames will not strike any portion of the logs.

Failure to properly place the logs will cause sooting and improper Carbon Monoxide output.

Periodically check the positioning of all logs to ensure proper log placement and stability. If any flame is striking the logs, recheck log placement. Adjust to conform with instructions. There should be no flame impingement on the logs.

Log placement should be re-checked as part of the fireplace maintenance procedure. Logs may not remain in their original position over time.

Vent Free Burner System Replacement Parts List

Note: Please refer to the list below for system part numbers each type of burner system by the kind of gas valve used. There are illustrations showing the individual burner components on the next several pages.

Parts may be ordered from your retailer where the gas burner had been purchased from.

| Burner System Part Numbers | | |
|----------------------------|--------------|----------------------|
| Valve Type | Assembly P/N | Size and Gas Type |
| Millivolt Variable Control | VF18V-NG | 18 Inch Log, Natural |
| Millivolt Variable Control | VF18V-LP | 18 Inch Log, Propane |
| Millivolt Variable Control | VF24V-NG | 24 Inch Log, Natural |
| Millivolt Variable Control | VF24V-LP | 24 Inch Log, Propane |
| Electronic | VF18E-NG | 18 Inch Log, Natural |
| Electronic | VF18E-LP | 18 Inch Log, Propane |
| Electronic | VF24E-NG | 24 Inch Log, Natural |
| Electronic | VF24E-LP | 24 Inch Log, Propane |

| Log Set Part Numbers | |
|----------------------|---------|
| Description | Part # |
| Oak – 18” | 946-832 |
| Oak – 24” | 946-833 |
| Birch – 18” | 946-834 |
| Birch – 24” | 946-835 |
| Description | Part # |
| 10lbs Lava Rock | 946-837 |

**BURNER PARTS LIST – VF18V-NG Vent-Free Burner Millivolt Variable 18 NG
VF18V-LP Vent-Free Burner Millivolt Variable 18 LP
VF24V-NG Vent-Free Burner Millivolt Variable 24 NG
VF24V-LP Vent-Free Burner Millivolt Variable 24 LP**

NOTE – Pictures are not to scale – 24/30 Burner model shown

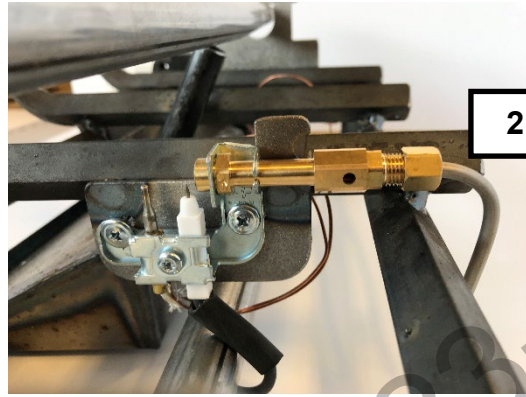

Note: Remote receiver is not shown but is included with remote handheld (Item 7).

Burner Parts List VF18V-NG / VF18V-LP

| | Part # | Description | Quantity |
|---|---------------|---|-----------------|
| 1 | 003-037 | NG GV34 Variable Control Valve | 1 |
| 1 | 003-038 | LP GV34 Variable Control Valve | 1 |
| 2 | 003-039 | Solid stranded ODS Pilot used with Maxitrol GV34 System NG | 1 |
| 2 | 003-040 | Solid stranded ODS Pilot used with Maxitrol GV34 System LP | 1 |
| 3 | N/A | 6 LBS BLACK LAVA ROCK | 1 |
| 4 | 003-041 | 1 OZ BAG BLACK GLOWING EMBERS | 1 |
| 5 | 003-042 | PLATINUM BRIGHT EMBER 1 GRAM | 1 |
| 6 | 003-008 | Damper Clamp | 1 |
| 7 | 003-043 | SkyTech Variable/Thermostat Remote & Receiver | 1 |

Burner Parts List VF24V-NG / VF24V-LP

| | Part # | Description | Quantity |
|---|---------------|---|-----------------|
| 1 | 003-037 | NG GV34 Variable Control Valve | 1 |
| 1 | 003-038 | LP GV34 Variable Control Valve | 1 |
| 2 | 003-039 | Solid stranded ODS Pilot used with Maxitrol GV34 System NG | 1 |
| 2 | 003-040 | Solid stranded ODS Pilot used with Maxitrol GV34 System LP | 1 |
| 3 | N/A | 6 LBS BLACK LAVA ROCK | 1 |
| 4 | 003-041 | 1 OZ BAG BLACK GLOWING EMBERS | 1 |
| 5 | 003-042 | PLATINUM BRIGHT EMBER 1 GRAM | 1 |
| 6 | 003-008 | Damper Clamp | 1 |
| 7 | 003-043 | SkyTech Variable/Thermostat Remote & Receiver | 1 |

**BURNER PARTS LIST – VF18E-NG Vent-Free Burner Electronic 18 NG
VF18E-LP Vent-Free Burner Electronic 18 LP
VF24E-NG Vent-Free Burner Electronic 24 NG
VF24E-LP Vent-Free Burner Electronic 24 LP**

NOTE – Pictures are not to scale – 24 Burner model shown

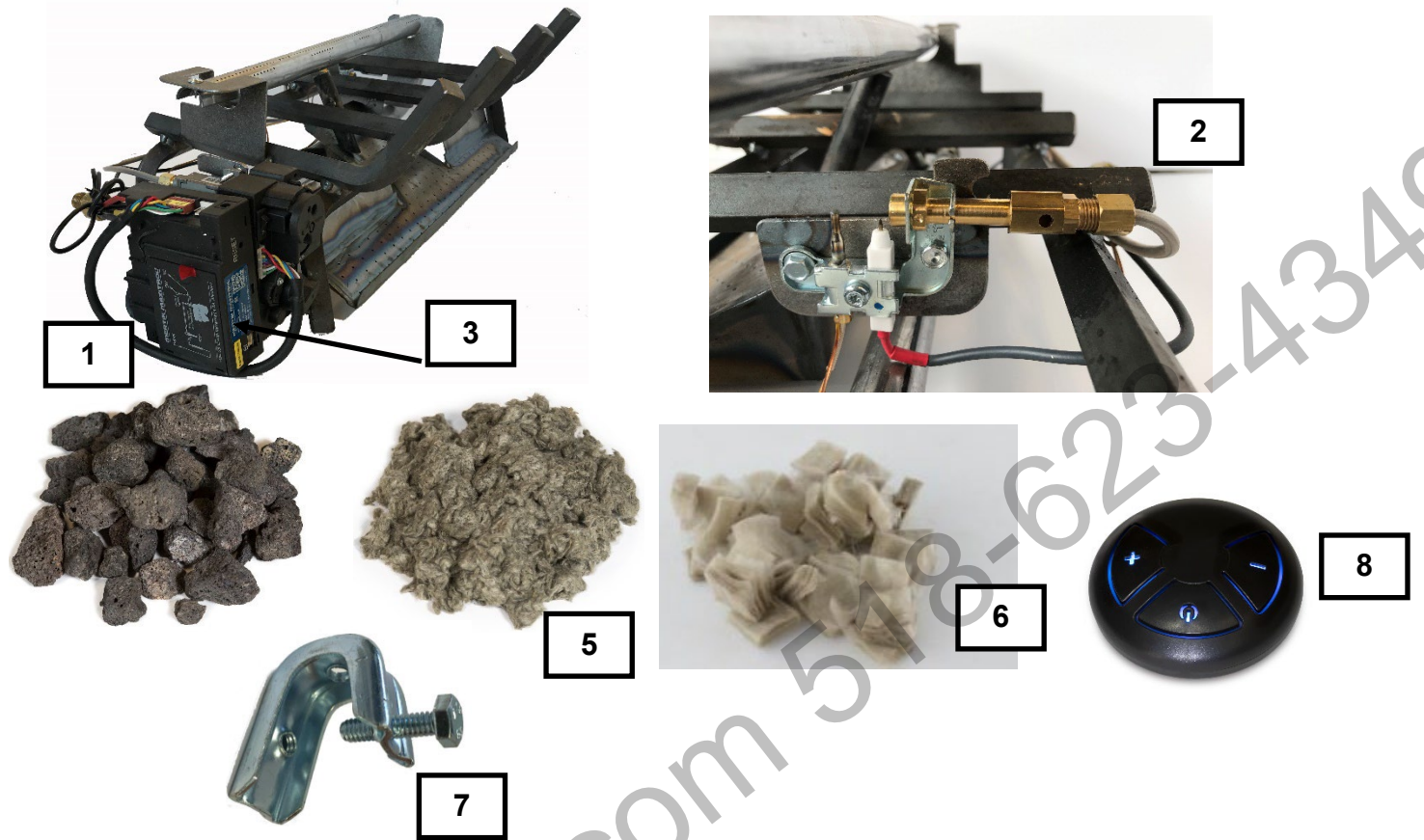

Burner Parts List VF18E-NG / VF18E-LP

| | Part # | Description | Quantity |
|---|---------------|---|-----------------|
| 1 | 003-044 | GAS CONTROL VALVE 6V ELECTRONIC NG | 1 |
| 1 | 003-045 | GAS CONTROL VALVE 6V ELECTRONIC LP | 1 |
| 2 | 003-046 | Interrupted ODS Pilot used with Maxitrol GV60 System NG | 1 |
| 2 | 003-047 | Interrupted ODS Pilot used with Maxitrol GV60 System LP | 1 |
| 3 | 003-049 | Symax GV60 ELE Receiver 2019 | 1 |
| 4 | N/A | 6 LBS BLACK LAVA ROCK | 1 |
| 5 | 003-041 | 1 OZ BAG BLACK GLOWING EMBERS | 1 |
| 6 | 003-042 | PLATINUM BRIGHT EMBER 1 GRAM | 1 |
| 7 | 003-008 | Damper Clamp | 1 |
| 8 | 003-048 | Puck Transmitter - Black | 1 |

Burner Parts List VF24E-NG / VF24E-LP

| | Part # | Description | Quantity |
|---|---------------|---|-----------------|
| 1 | 003-044 | GAS CONTROL VALVE 6V ELECTRONIC NG | 1 |
| 1 | 003-045 | GAS CONTROL VALVE 6V ELECTRONIC LP | 1 |
| 2 | 003-046 | Interrupted ODS Pilot used with Maxitrol GV60 System NG | 1 |
| 2 | 003-047 | Interrupted ODS Pilot used with Maxitrol GV60 System LP | 1 |
| 3 | 003-049 | Symax GV60 ELE Receiver 2019 | 1 |
| 4 | N/A | 6 LBS BLACK LAVA ROCK | 1 |
| 5 | 003-041 | 1 OZ BAG BLACK GLOWING EMBERS | 1 |
| 6 | 003-042 | PLATINUM BRIGHT EMBER 1 GRAM | 1 |
| 7 | 003-008 | Damper Clamp | 1 |
| 8 | 003-048 | Puck Transmitter - Black | 1 |

Indoor Gas Limited Lifetime Warranty

FPI Fireplace Products International Ltd. (for Canadian customers) and Fireplace Products US, Inc. (for US customers) (collectively referred to herein as “FPI”) extends this Limited Lifetime Warranty to the original purchaser of this Appliance provided the product remains in the original place of installation. The items covered by this Limited Lifetime Warranty and the period of such coverage are set forth in the table below.

An Appliance in this policy is defined as an Indoor vented or vent free Gas Burner.
This Appliance has only been certified and listed for use indoors.

This Limited Lifetime Warranty starts on the day the Appliance was purchased.
The Limited Lifetime Warranty is not transferable, amendable or negotiable under any circumstances.

| Indoor Gas Products Warranty Coverage Parts and Labor | Parts Limited Lifetime | Parts 2 years | Subsidized Labor Coverage* (Years) |
|--|------------------------------|------------------|--|
| **Log sets/Burners/Burner Tubes/Grates | ✓ | | 1 |
| Valve assembly and all gas control components (Pilot assembly, flame sensors, Spark Electrode, Pilot Tubing, Orifices, Thermocouple, ODS Pilot) | | ✓ | 1 |
| All Other Electrical components (Ignition Control Boards, Wiring, Switches, Battery Pack, Remote Control Systems) | | ✓ | 1 |

Note: Warranty coverage noted above may not be applicable as components/options vary based on appliance purchased.

Conditions:

Warranty protects against defect in manufacture or FPI factory-assembled components only, unless herein specified otherwise.

***This warranty does not cover dealer travel costs, mileage, fuel, tolls for diagnostic or service work. All labor rates paid to authorized dealers are subsidized, pre-determined rates. Dealers may charge you for travel and additional time beyond their subsidy.**

Any part(s) found to be defective during the warranty period as outlined above will be repaired or replaced at FPI’s option through an accredited distributor, dealer or pre-approved and assigned agent; provided that the defective part is returned to the distributor, dealer or agent for inspection if requested by FPI. Alternatively, FPI may, at its discretion, fully discharge all of its obligations under warranty by refunding the verified purchase price of the product to the original purchaser. The purchase price must be confirmed by the original Bill of Sale. **The authorized selling dealer, or an alternative authorized FPI dealer if pre-approved by FPI, is responsible for all in-field**

diagnosis and service work related to all warranty claims. FPI is not responsible for results or costs of workmanship of unauthorized FPI dealers or agents in the negligence of their service work.

At all times, FPI reserves the right to inspect reported in the field/on location complaints of products claimed to be defective before processing or authorizing any claim. Failure to allow this upon request will void the warranty.

All warranty claims must be submitted by the dealer servicing the claim, including a copy of the Bill of Sale (proof of purchase by you). All claims must be complete and provide full details as requested by FPI to receive consideration for evaluation. **Incomplete claims may be rejected.**

****Replacement Burners/Burners Tubes/Log Sets/Grates to the original purchaser are limited to one per warranty term.** Appliances must be installed according to all manufacturers' instructions as per the manual. All Local and National required codes must be met.

The installer is responsible for ensuring the Appliance is operating as designed at the time of installation.

The original purchaser is responsible for the annual maintenance of the Appliance, as outlined in the owner's manual. As outlined below, the warranty may be voided due to problems caused by a lack of maintenance.

Purchased parts: Repair/replacement parts purchased by the consumer from FPI after the original coverage has expired on the Appliance will carry a **90-day** warranty from the purchase date, valid with a receipt only. Any item shown to be defective will be repaired or replaced at our discretion. No labor coverage is included with these parts.

If freight damage has been found either externally or internally, the dealer must be informed within 3 days. All claims as a result of damage must be submitted by the dealer servicing the claim, including a copy of the Bill of Sale (proof of purchase). All claims must be complete and provide full details as requested by FPI to receive consideration for evaluation. **Incomplete claims may be rejected.**

As this is a Limited Lifetime Warranty, if the Appliance needs to be replaced, the Appliance that was purchased at the time of sale might not be replaced with exactly the same model Appliance. In that case, FPI will replace your Appliance with one that is similar at the time of replacement under the terms of this Limited Lifetime Warranty, but **ONLY** in the event that an item covered by the Limited Lifetime Warranty is found to be defective. Please refer to the table on first page of this warranty for items covered by the Limited Lifetime Warranty. Product changes might be the result of the original Appliance being discontinued, changes in regulatory requirements, product advancements, etc., which are beyond the control of FPI. **This Limited Lifetime Warranty does not cover any installation costs, or costs associated with changes of required clearances for the replacement Appliance, hearth pads, mantles, facing and/or facing materials such as framing, completed walls made of drywall, wood, non-combustible board, tile, brick, stone, marble etc., venting/chimney systems, or components of the chimney system.**

If a suitable replacement is not available, FPI will refund **50%** of the purchase price of the Appliance and any applicable FPI accessories (faceplates, brick panels, media, etc.) purchased at the time of sale. **In no event will FPI refund any portion of the purchase price**

of, or reimburse costs associated with, any other items, including without limitation, installation of a new Appliance, changes of required clearances for a new Appliance, hearth pads, mantles, facing and/or facing materials such as framing, completed walls made of drywall, wood, non-combustible board, tile, brick, stone, marble etc., venting/chimney systems, or components of the chimney system. A copy of the receipt or bill of sale will be necessary to validate the purchase price.

Exclusions:

This Limited Lifetime Warranty does not extend to paint, rust or corrosion of any kind due to a lack of maintenance or improper venting, combustion air provision, corrosive chemicals (i.e. chlorine, salt, air, etc.), door or glass gasketing, batteries, lava rock, platinum/glowing embers, vermiculite.

**This Limited Lifetime warranty does not cover color fading, carbon/sooting of the log sets due to use.

Malfunction, damage or performance-based issues as a result of environmental conditions, location, chemical damages, downdrafts, installation error, an installation by an unqualified installer, incorrect chimney components (including but not limited to cap size or type), operator error, abuse, misuse, use of improper fuels, lack of regular maintenance and upkeep, acts of God, weather-related problems from hurricanes, tornados, earthquakes, floods, lightning strikes/bolts or acts of terrorism or war, which result in a malfunction of the Appliance are not covered under the terms of this Limited Lifetime Warranty.

FPI has no obligation to enhance or modify any Appliance once manufactured (i.e. as products evolve, field modifications or upgrades will not be performed on existing Appliances).

Any Appliance showing signs of neglect or misuse will not be covered under the terms of this warranty policy and may void this warranty, including Appliances with rust or corrosion that have not been reported as rusted or corroded within **three (3)** months of installation/purchase.

Appliances which show evidence of being operated while damaged, or with problems known to the purchaser and causing further damages will void this warranty.

Appliances where the serial no. has been altered, deleted, removed or made illegible will void this warranty.

Minor movement, expansion and contraction of the steel is normal and is not covered under the terms of this warranty.

Freight damages for products or parts are not covered under the terms of the warranty.

Products made or provided by other manufacturers and used in conjunction with the FPI Appliance without prior authorization from FPI may void this warranty.

Limitations of Liability:

The original purchaser's exclusive remedy under this warranty, and FPI's sole obligation under this Limited Lifetime Warranty, express or implied, in contract or in tort, shall be limited to replacement, repair, or refund, as outlined above. IN NO EVENT WILL FPI BE LIABLE UNDER THIS WARRANTY FOR ANY INCIDENTAL OR CONSEQUENTIAL COMMERCIAL DAMAGES OR DAMAGES TO PROPERTY. TO THE EXTENT PERMITTED BY APPLICABLE LAW, FPI MAKES

NO EXPRESS WARRANTIES OTHER THAN THE WARRANTY SPECIFIED HEREIN. THE DURATION OF ANY IMPLIED WARRANTY IS LIMITED TO DURATION OF THE EXPRESSED WARRANTY SPECIFIED ABOVE. IF IMPLIED WARRANTIES CANNOT BE DISCLAIMED, THEN SUCH WARRANTIES ARE LIMITED IN DURATION TO THE DURATION OF THIS WARRANTY.

Some US states do not allow limitations on how long an implied warranty lasts, or allow exclusion or limitation of incidental or consequential damages, so the above limitations or exclusions may not apply to you.

Customers located outside the US should consult their local, provincial or national legal codes for additional terms, which may apply to this warranty.

How to Obtain Warranty Service:

Customers should contact the authorized selling dealer to obtain warranty service. In the event the authorized selling dealer is unable to provide warranty service, please contact FPI by mail at the address listed below. Please include a brief description of the problem and your address, email and telephone contact information. A representative will contact you to make arrangements for an inspection and/or warranty service.

Canadian Warrantor:

FPI Fireplace Products International Ltd.
6988 Venture St.
Delta, British Columbia
Canada, V4G 1H4

U.S. Warrantor:

Fireplace Products US, Inc.
PO Box 2189 PMB 125
Blaine, WA
United States, 98231

Or contact the Regency Customer Care Centre at 1-800-442-7432 (phone) / 604-946-4349 (fax) / customerservice@regency-fire.com (e-mail)

Product Registration and Customer Support:

Thank you for choosing a Regency Fireplace. Regency strives to be a world leader in the design, manufacture, and marketing of hearth products. To provide the best support for your product, we request that you complete a product registration form at <http://www.regency-fire.com/Customer-Care/Warranty-Registration.aspx> within **ninety (90)** days of purchase.

CozyCabin.com 518-623-4349

CozyCabin.com 518-623-4349