



# H4 SERIES



## DV Gas Fireplace Heater 650ILN/ILP (Logs) & 650IRN/IRP (Rocks) Installation & Owner's Manual

### **WARNING**



**HOT GLASS WILL CAUSE BURNS.**  
**DO NOT TOUCH GLASS UNTIL COOLED.**  
**NEVER ALLOW CHILDREN TO TOUCH GLASS.**

**INSTALLER**  
Leave this manual with the appliance.

**CONSUMER**  
Retain this manual for future reference.

**WARNING:** If the information in these instructions is not followed exactly, a fire or explosion may result causing property damage, personal injury or loss of life.

Do not store or use gasoline or other flammable vapors and liquids in the vicinity of this or any other appliance.

#### WHAT TO DO IF YOU SMELL GAS

- Do not try to light the appliance.
- Do not touch any electrical switch; do not use any phone in your building.
- Immediately call your gas supplier from a neighbor's phone. Follow the gas supplier's instructions.
- If you cannot reach your gas supplier, call the fire department.

Installation and service must be performed by a qualified installer, service agency or the gas supplier.

Please read this manual **BEFORE** installing and operating this appliance.

This appliance may be installed in an after-market permanently located, manufactured (mobile) home where not prohibited by local codes.

This appliance is only for use with the type of gas indicated on the rating plate. This appliance is not convertible for use with other gases, unless a certified kit is used.

This appliance is a domestic room-heating appliance. It must not be used for any other purposes such as drying clothes, etc.

This appliance is suitable for installation in a bedroom or bed sitting room.

**Massachusetts:** The piping and final gas connection must be performed by a licensed plumber or gas fitter in the State of Massachusetts. Also, see Carbon Monoxide Detector requirements on page 16.

Ce guide est disponible en français sur demande.

Manufactured by  
**MILES INDUSTRIES LTD.**, British Columbia, Canada  
[www.valorfireplaces.com](http://www.valorfireplaces.com)



# Table of Contents

## FOR THE OWNER

Safety Precautions .....	3
Safety and Your Fireplace .....	4
Owner's Information .....	5
Remote Control Operation.....	9
Wall Switch Operation .....	13
Options .....	14
Lighting Instructions.....	15
Warranty .....	45

**Warranty Card at the back of this manual.**



## FOR THE QUALIFIED INSTALLER

Commonwealth of Massachusetts.....	16
Specifications .....	18
Overview.....	19
Dimensions.....	20
Framing .....	21
Location .....	22
Venting.....	22
Co-Axial Venting.....	23
Co-Linear Venting.....	29
Appliance Preparation .....	30
Gas Supply Installation.....	33
Liner Panels Installation .....	34

Ceramic Logs Installation (650IL).....	35
Ceramic Rocks Installation (650IR).....	36
Window Refitting & Baffle Installation.....	38
Wall Switch Kit Installation (required) .....	39
Remote Control Initial Set-up .....	40
Operation Check & Aeration Settings Adjustment.....	40
Remote Control Handset Wall Holder Installation .....	41
Wiring Diagram.....	42
Approved Venting Components.....	43
Warranty .....	45
Replacement Parts .....	46



We recommend that our gas hearth products be installed and serviced by professionals who are certified in the U.S. by the National Fireplace Institute® (NFI) as NFI Gas Specialists.

[www.nficertified.org](http://www.nficertified.org)

The information contained in this installation manual is believed to be correct at the time of printing. Miles Industries Ltd. reserves the right to change or modify any information or specifications without notice. Miles Industries Ltd. grants no warranty, implied or stated, for the installation or maintenance of your heater, and assumes no responsibility for any consequential damage(s).

**Designed and Manufactured by / for**  
**Miles Industries Ltd.**  
 190-2255 Dollarton Highway, North Vancouver, BC, CANADA V7H 3B1  
 Tel. 604-984-3496 Fax 604-984-0246  
[www.valorfireplaces.com](http://www.valorfireplaces.com)  
 © Copyright Miles Industries Ltd., 2012



## Safety Precautions

**READ** and **UNDERSTAND** all instructions carefully before starting the installation. **FAILURE TO FOLLOW** these installation instructions may result in possible fire hazard and will void the warranty.

Prior to the first firing of the fireplace, **READ** the Owner's Information section of this manual.

**DO NOT USE** this appliance if any part has been under water. Immediately, **CALL** a qualified service technician to inspect the unit and to replace any part of the control system and any gas control that has been under water.

### **THIS UNIT IS NOT FOR USE WITH SOLID FUEL.**

Installation and repair should be **PERFORMED** by a qualified service person. The appliance and venting system should be **INSPECTED** before initial use and at least annually by a professional service person. More frequent cleaning may be required due to excessive lint from carpeting, bedding, etc. It is **IMPERATIVE** that the unit's control compartment, burner, and circulating air passageways **BE KEPT CLEAN** to provide for adequate combustion and ventilation air.

Always **KEEP** the appliance clear and free from combustible materials, gasoline, and other flammable vapors and liquids.

**NEVER OBSTRUCT** the flow of combustion and ventilation air. Keep the front of the appliance **CLEAR** of all obstacles and materials for servicing and proper operation.

Due to the high temperature, the appliance should be **LOCATED** out of traffic areas and away from furniture and draperies. Clothing or flammable material **SHOULD NOT BE PLACED** on or near the appliance.

Clothing or flammable material **SHOULD NOT BE PLACED** on or near the appliance.

Children and adults should be **ALERTED** to the hazards of high surface temperature and should **STAY AWAY** to avoid burns or clothing ignition.

**YOUNG CHILDREN** should be **CAREFULLY SUPERVISED** when they are in the same room as the appliance. Toddlers, young children and others may be susceptible to **ACCIDENTAL CONTACT BURNS**. A physical barrier is recommended if there are at risk individuals in the house. To restrict access to a fireplace or stove, **INSTALL AN ADJUSTABLE SAFETY GATE** to keep toddlers, young children and other at risk individuals out of the room and away from hot surfaces.

This unit **MUST** be used with a vent system as described in this installation manual. **NO OTHER** vent system or components **MAY BE USED**.

This gas fireplace and vent assembly **MUST** be vented directly to the outside and **MUST NEVER** be attached to a chimney serving a separate solid fuel burning appliance. Each gas appliance **MUST USE** a separate vent system. Common vent systems are **PROHIBITED**.

**INSPECT** the external vent cap on a regular basis to make sure that no debris, plants, trees, shrubs are interfering with the air flow.

The glass door assembly **MUST** be in place and sealed before the unit can be placed into safe operation.

**DO NOT OPERATE** this appliance with the glass door removed, cracked, or broken. Replacement of the glass door should be performed by a licensed or qualified service person. **DO NOT** strike or slam the glass door.

The glass door assembly **SHALL ONLY** be replaced as a complete unit, as supplied by the fireplace manufacturer. **NO SUBSTITUTE** material may be used.

**DO NOT USE** abrasive cleaners on the glass door assembly. **DO NOT ATTEMPT** to clean the glass door when it is hot.

**TURN OFF** the gas before servicing this appliance. It is recommended that a qualified service technician perform an appliance check-up at the beginning of each heating season.

Any safety screen or guard removed for servicing **MUST BE REPLACED** prior to operating this appliance.

**DO NOT** place furniture or any other combustible household objects within 36" of the fireplace front.

**BE CAREFUL** not to put any decorating objects sensitive to heat to close above or around the fireplace as it gets very hot when operating.

**DO NOT** use this heater as a temporary source of heat during construction.

This appliance is a **DOMESTIC ROOM-HEATING APPLIANCE**. It must not be used for any other purposes such as drying clothes, etc.

---

**State of California. Proposition 65 Warning.** Fuels used in gas, wood-burning or oil fired appliances, and the products of combustion of such fuels, contain chemicals known to the State of California to cause cancer, birth defects and other reproductive harm. California Health & Safety Code Sec. 25249.6.

# Safety and Your Fireplace

## Please Read and Carefully Follow all Safety Warnings and Operating Instructions Contained in Your Owners Manual

(Replacement Manuals are available by contacting our service department at 1-800-468-2567 or visit [www.valorfireplaces.com](http://www.valorfireplaces.com)).

### Please Follow These Important Child Safety Precautions and Recommendations,

- Parts of your Valor Fireplace become **extremely hot** while in operation.
- The glass viewing **window temperature can exceed 500 F** at full capacity. Momentary contact with a hot glass surface can **cause a severe burn**, even if the fireplace is operating at reduced heating capacity.
- **The glass window will remain hot** for an extended period of time after the fireplace has been turned off. Ensure that children are prevented from touching the fireplace during the cool down period.
- **Toddlers and Young Children must be closely supervised at all times** when they are in the same room as the operating fireplace. They lack full awareness of danger and rely on your protection. Toddlers, in particular, do not have the motor skills and response reflexes to



withdraw in the event of accidental contact with a hot surface.

- **A physical barrier is strongly recommended** if there are young children, or at-risk individuals in the house. Install an approved after-market safety gate to keep toddlers, young children and other at-risk individuals a safe distance from the fireplace.
- **Keep the remote control handset out of reach of children at all times.** A wall mount storage holster is provided with your remote control handset.
- **Ensure that the fireplace, including the pilot light, is completely turned off** when children are present and close supervision and safety barriers are not available—see page 8 of *Owner's Information* section.
- If the fireplace is not going to be used for the summer or any extended period of time, **remove the batteries from the remote control handset and receiver.** It is recommended that batteries are replaced annually in any event—see page 7.

**⚠ WARNING**

**EXTREMELY HOT!!!**

- **READ the SAFETY information on pages 3 and 4 of this manual BEFORE operating your gas heater.**
- Some parts of your fireplace are **EXTREMELY HOT**, particularly the **GLASS** window.
- **DO NOT LET CHILDREN** touch the glass or any parts of your fireplace **even after it is turned off** as it is still hot.
- **USE A SAFETY SCREEN or a GATE** to reduce the risk of burns.
- Keep the remote control handset **OUT OF REACH** of children.
- **HOT HEARTH / FLOOR!** The hearth or floor in front of the fireplace may become very hot when the fireplace heats. Do not use the hearth as a seat or shelf.
- Some materials or items, although safe, may discolor, shrink, warp, crack, peel, and so on because of the heat produced by the fireplace. **AVOID PLACING** candles, paintings, photos, and other items **SENSITIVE TO HEAT** within 36 inches (0.9 m) around the fireplace.
- Solid wood flooring in front of the fireplace (if allowed) may shrink during the heating season due to heat.

**Performance of LPG appliances may be affected by the quality of commercial gas supplied in your area.**

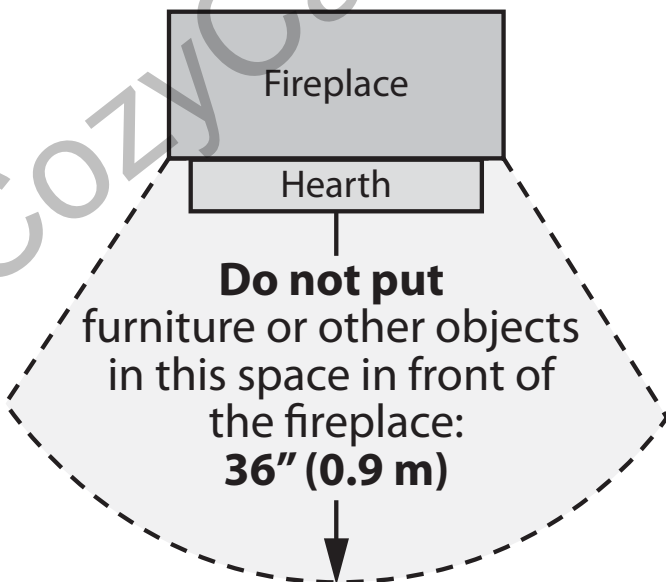

**Thank You ...**

For purchasing a Valor by Miles Industries. Your new radiant gas heater is a technical appliance that must be installed by a qualified dealer. Each Valor fireplace is fully tested during the production process for your safety and comfort.

Your unit has been professionally installed by:

Dealer Name: \_\_\_\_\_

Phone Number : \_\_\_\_\_

**Should you encounter an operational problem, call your dealer immediately.**

**Do not try to repair the unit as you may cause an injury or damage the fireplace.**

**This manual and particularly the preceding and following pages contain very important information regarding the safe operation of your fireplace as well as maintenance instructions.**

**Read carefully BEFORE operating your fireplace and pay special attention to the SAFETY WARNINGS.**

A heating gas appliance does require safe handling and for this reason, we very strongly recommend that no children be allowed to touch the fireplace and its controls at all times. **Do install a screen or barrier in front of the fireplace to protect your children against severe burns.**

**Operating Your Fireplace for the First Time**

When operating your new fireplace for the first time, some vapors may be released due to the burning of curing compounds used in the manufacture of the appliance. They may cause a slight odor and could cause the flames to be the full height of the firebox, or even slightly higher, for the first few hours of operation.

It is also possible that these vapors could set off any smoke detection alarms in the immediate vicinity.

These vapors are quite normal on new appliances. We recommend opening a window to vent the room. After a few hours use, the vapors will have disappeared and the flames will be at their normal height.

**Flame Supervision Device**

For your safety, this appliance is fitted with a flame supervision device which will shut-off the gas supply if, for any reason, the pilot flame goes out. This device incorporates a fixed probe, which senses the heat from the pilot flame. If the probe is cool, the device will prevent any gas flow unless manually lighting the pilot. See full lighting instructions on page 15 of this manual.

**Cleaning**

**! WARNING**

**DO NOT TOUCH THE GLASS WHILE IT IS HOT!**  
Let the fireplace cool first before cleaning it.

**Important - Glass cleaning - Mineral deposits**

One of the by-products of the combustion process in a gas appliance is a mineral which can show up as a white film on the ceramic glass viewing door.

The composition of the deposit varies widely with location and time. It believed to be associated with the varying sulfur content of the gas. You may have the problem intermittently.

We have consulted with ceramic glass manufacturers and they cannot give us a definitive solution to this problem. Dealers have tried various cleaning products with varying results. The following are recommendations only and are not meant to guarantee results.

**NOTE: This is a problem beyond Miles Industries' control and is not covered under warranty.**

- Clean the glass regularly as soon as you notice the buildup (white film). If the film is left for a longer period of time, it will bake on. It is then much harder, if not impossible, to remove.
- **NEVER use an abrasive cleaner** on the ceramic glass. Any abrasion of the surface has the immediate effect of compromising the strength of the glass. An emulsion type cleaner is recommended.
- Use a soft damp cloth to apply the cleaner. Dry the glass with a soft, dry, preferably cotton cloth. Most paper towels and synthetic materials are abrasive to ceramic glass and should be avoided.
- Our dealers have had good results from the products listed below. We cannot, however, guarantee the results of these products.
  - BRASSO, POLISH PLUS by KELKEM, COOK TOP CLEAN CREME by ELCO, WHITE OFF by RUTLAND, TURTLE WAX

**DO NOT CLEAN THE GLASS WHILE IT IS HOT!**  
Always securely replace the window before lighting.  
**If broken, the glass pane may only be replaced as a complete window unit as supplied by the manufacturer.**

To remove the window for cleaning:

1. Unhook the window baffle located on top of the window frame.
2. Turn the top two spring-loaded window bolts through 90 degrees to release the window from the firebox.
3. Remove the bottom two spring-loaded window bolts.
4. Carefully lift the window away. Keep the window, window baffle, and bolts in a safe place.

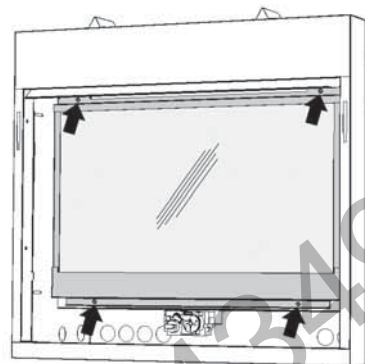

To refit the window:

1. Slide the window inside the appliance case and rest it on the firebox front bottom tabs. Refit the bottom two bolts. The bolts should be screwed in securely.
2. Refit the top two bolts securing by turning them through 90 degrees.
3. Hook the window baffle to the top of the window frame. *Be careful not to hook it onto the firebox frame—see image below and page 38.*

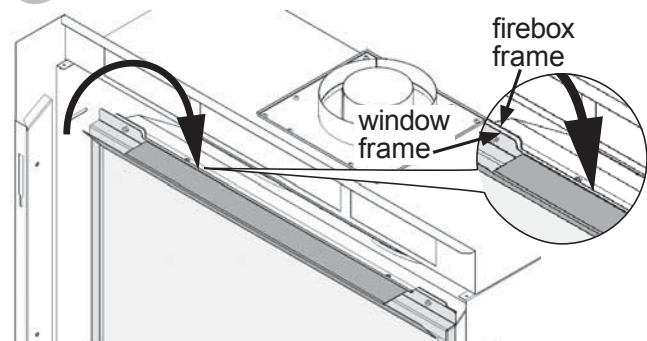

(appliance shown without its front frame for clarity)

4. Grab the top of the window and baffle and pull them forward and release to check that the window opens slightly and returns confirming the good function of the spring-loaded mechanism.
5. Similarly check the bottom of the window by pulling it forward and releasing.

**IMPORTANT:** To ensure a safe operation, ensure that the spring-loaded mechanism functions properly.

6. Apply light hand pressure against the window frame sides to bed in the window seal.

7. If the Hot Glass Warning plate has been removed from the front lower corner of the window, reinstall it by sliding it between the glass and the frame as indicated.



Soot or dust can be brushed from the ceramic rocks and firebox walls using a soft brush. Dust can also be removed from the burner using a soft brush after removing the ceramic logs. When cleaning, make sure that no particles are brushed into the slots of the burner.

### Checks

A periodic check of the pilot and burner flames should be made. Check after the fire has been on for at least 30 minutes. The pilot flame must cover the tip of the thermocouple probe. The main burner flame pattern will vary from appliance to appliance depending on the type of installation and climatic conditions.



Correct Flame Picture—Logs

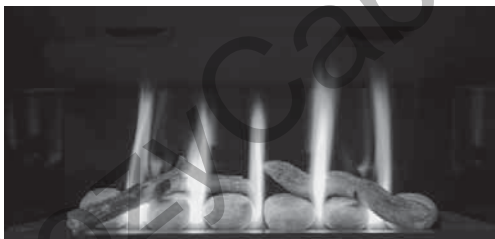

Correct Flame Picture—Rocks

Pilot Flame can be seen between logs or left of first rock

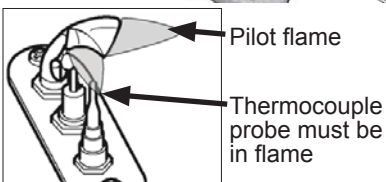
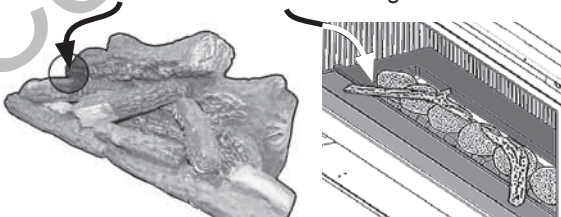

### Rock fuel bed

A black discoloration may form over time at the front bottom of the 6-rock original fuel bed; this deposit can be burned off by running the fireplace on a low to medium setting fire for 30 to 45 minutes. This discoloration is unavoidable and will re-form again.

The appliance area must always be kept clear and free from combustible materials, gasoline and other flammable vapors and liquids.

Inspect the vent terminal outdoors regularly to make sure that snow, trees, bushes, leaves, or other objects do not obstruct it.

Examine the vent system and terminal regularly. We recommend annually.

### Remote Control Handset Wall Holder

Your fireplace equipment includes a wall holder to store the handset. If it hasn't be installed, refer to the instructions further on in this manual for the installation.



### Batteries

#### ! WARNING

**DO NOT ATTEMPT TO CHANGE THE BATTERIES WHILE THE FIREPLACE IS STILL HOT!** Let the fireplace cool first before touching it.

#### CAUTION

**DO NOT USE** a screwdriver or other metallic object to remove the batteries from the receiver or the handset! This could cause a short circuit to the receiver.

**Low battery signal: see page 13.**

**BEFORE changing the batteries, turn off the valve using the wall switch's On/Off button.**

The appliance uses four 1.5 V AA alkaline batteries for its remote control receiver and one 9 V alkaline battery for its handset. The batteries should last one to two seasons, depending on usage. Removing the batteries in the off-season will extend the battery life. Should the batteries loose power, the control may be operated by manually turning the control knob at the valve or by turning off the valve at the switch.

**To replace the batteries in the remote control receiver:**

1. The receiver is located to the left of the valve and it is retained to the firebox by a *Velcro* tab. Grab the receiver and pull it out from its location.

2. Slide and remove the receiver cover.
3. Replace the 4 AA batteries.
4. Replace the cover.
5. Put the receiver back in its position pushing it in so it attaches to the *Velcro* tab.

**Lighting, Operation and Rating Information**

**⚠ WARNING**

**DO NOT ATTEMPT TO TOUCH THE DATA PLATE WHILE THE FIREPLACE IS STILL HOT!** Let the fireplace cool first before touching it.

The Lighting, Operation and Rating information is located on a plate under the firebox.

To access the plate, remove any fret or access panel and grab the plate and slide it out to read it. There is important information on both sides of the plate.

**Servicing**

If any attention is required for your appliance, contact your supplier quoting the model number. It will be helpful if the appliance's serial number can also be quoted. This number is on the rating plate, which is located under the burner. The replacement parts are shown at the end of this manual. Please always quote the part number and description when requesting spare parts.

**Fireplace Control Devices**

There are two ways to control your fireplace.

1. Thermostatic Remote Control;
2. Wall Switch.

The Thermostatic Remote Control can be programmed to function automatically—see pages 9–13.

The Wall Switch can be used to turn on, off and to increase or decrease the flame height—see page 13.

**NOTE:** The remote control in the AUTO mode will override the wall switch.



Thermostatic Remote Control

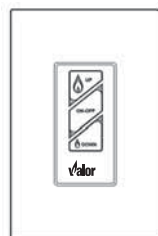

Wall Switch

**How to Turn Your Fireplace OFF (including pilot)**

Familiarize yourself with each of these methods before operating your fireplace.

**Handset and Wall Switch:** Press and hold the OFF button for a second (either on the handset or the wall switch).

If the flames are on, they go down and you hear the valve motor wind down. You hear a clunk and a beep indicating that the valve has received the signal from the remote control.

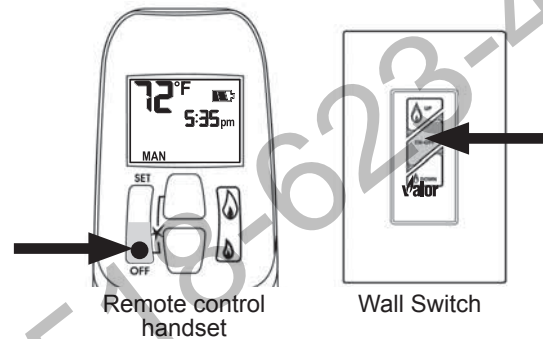

**How to Ensure Your Fireplace Cannot Be Turned ON Inadvertently**

You can use one of the two following methods to ensure that your fireplace will not turn on when you don't want it on.

**First, ensure your fireplace is turned off—including the pilot—and cold BEFORE going ahead.**

- Turn the dial on the gas valve from the ON position to the MAN position as shown. Turning the dial to MAN (arrow up) will ensure that the main burner can not come on. The pilot will remain on if it is lit.

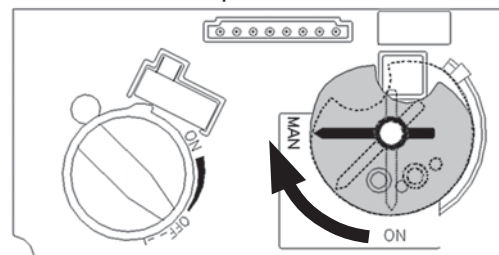

Gas valve

- Alternately, remove all batteries from the receiver as well as the battery from the handset.

**Automatic Shut-Off (in certain conditions)**

Your fireplace's remote control is equipped with an automatic shut-off mechanism which is activated in certain conditions. See page 13 in the *Remote Control Operation* section for a description of this feature.

# Remote Control Operation

**NOTE:** Before using the remote control system for the first time, the receiver and the handset must be synchronized. See the section *Remote Control Initial Set-up* on page 40 of this manual.

**IMPORTANT:** BEFORE YOU BEGIN, please note that on this system, the settings of time, temperature and automatic ON/OFF can only be programmed when the function display is flashing. Be patient when programming as it can take a few seconds to set.

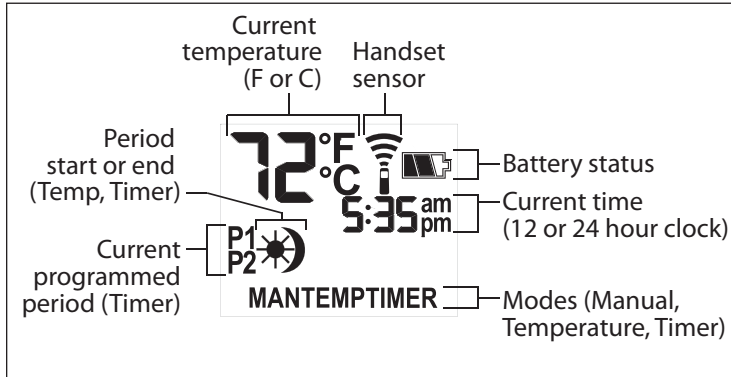

Display Overview

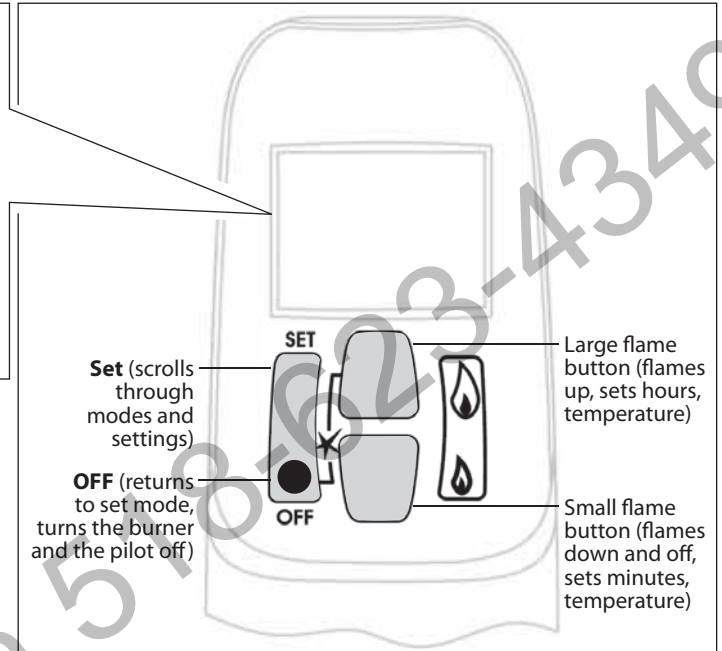

Handset Overview

Note: In the TEMP or TIMER modes, the remote handset senses the room temperature and adjusts the flame accordingly.

To communicate, the handset should be within 15 feet (4.5 meters) of the fireplace.

**Do not leave the handset on the mantel or hearth.**

## TO TURN ON APPLIANCE

### CAUTION

When pilot ignition is confirmed, motor turns automatically to maximum flame height.

- On the valve, turn MAN knob on the ON, full counterclockwise position.
- Place ON/OFF switch (if equipped) in I (ON position).
- Simultaneously press the OFF and (large flame) buttons until a short beep confirms the start sequence has begun; release buttons.
- Continuing beeps confirm the ignition is in process.
- Once pilot ignition is confirmed, there is main gas flow.
- After main burner ignition the handset will automatically go into manual (MAN) control mode.

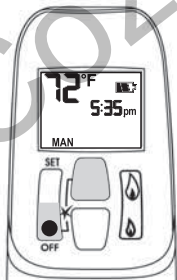

## TO TURN OFF APPLIANCE

- Press OFF button.

When the pilot is off, it will take 2 minutes before it can be lit again.



### STANDBY MODE (Pilot Flame)

- Press and hold (small flame) to set appliance at pilot flame.

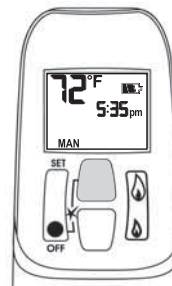

### FLAME HEIGHT ADJUSTMENT

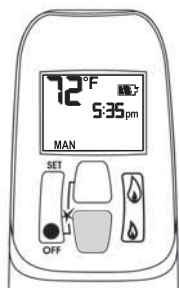

- In standby mode: Press and hold (large flame) button to increase flame height.

## Remote Control Operation



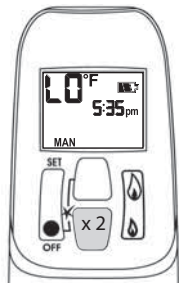

- Press and hold  (small flame) button to decrease flame height or to set the appliance at pilot flame.
- For fine adjustment tap the  (large flame) or  (small flame) buttons.

### Express Low and High Fire



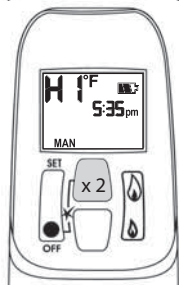

- Double-click  (small flame) button. "LO" will be displayed.  
NOTE: Flame goes to high fire first before going to designated low fire.



- Double-click  (large flame) button. Flame automatically goes to high fire. "HI" will be displayed.

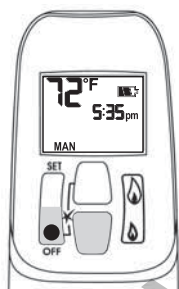



### SETTING °C/24-HOUR OR °F/12-HOUR CLOCK

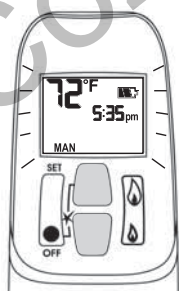

- In MAN mode, press OFF and  (small flame) buttons until display changes from Fahrenheit/12-hour clock to Celsius/24-hour clock and vice versa.

### SETTING THE TIME





- The time display will flash after either:
  - Installing the battery or
  - Simultaneously pressing the  (large flame) and  (small flame) buttons.
- Press  (large flame) button to set the hour.
- Press  (small flame) button to set the minute.
- Press OFF or simply wait to return to MAN mode.

### MODES OF OPERATION

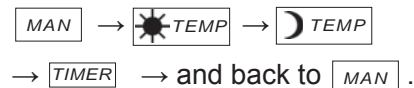

- Briefly pressing the SET button changes the mode of operation in the following order:



**NOTE:** Manual mode can also be reached by pressing either the  (large flame) or the  (small flame) buttons.

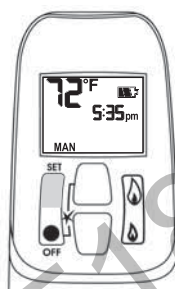

-  - **Manual Mode** - Manual Flame Height Adjustment.

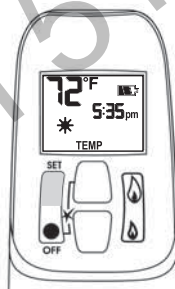

-  TEMP - **Daytime Temperature Mode** (Appliance must be in standby mode; pilot ignited) - The room temperature is measured and compared to the set temperature. The flame height is then automatically adjusted to achieve the Daytime Set Temperature.



-  TEMP - **Nighttime Setback Temperature Mode** (Appliance must be in standby mode; pilot ignited) - The room temperature is measured and compared to the Nighttime Setback temperature. The flame height is then automatically adjusted to achieve the Night-time Setback Temperature.



-  - **Timer Mode** (Appliance must be in standby mode; pilot ignited) - The timers P1 and P2 (Program 1, Program 2) each can be programmed to go ON and OFF at specific times. For instructions see Timer Programming Mode.

**NOTE:** The display shows the set temperature every 30 seconds.

# Remote Control Operation

## SETTING THE ON / OFF TEMPERATURES

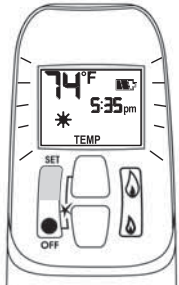

### SETTING THE "DAYTIME" TEMPERATURE

Default Settings:  TEMP (sun), 23°C / 74°F



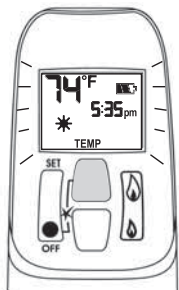

- Briefly press SET button to scroll to TEMP  (sun) mode. Hold the SET button until the TEMP flashes.

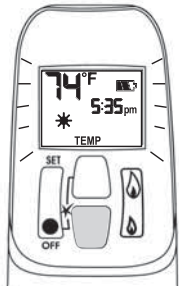

- Press  (large flame) button to increase the  Daytime Set Temperature.



- Press  (small flame) button to decrease  Daytime Set Temperature.

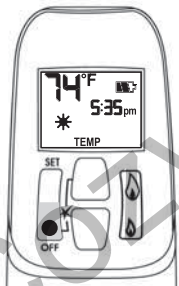

- Press OFF or simply wait to complete programming.

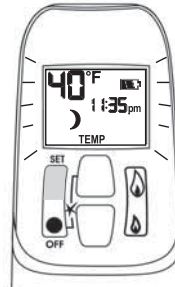

### SETTING THE "NIGHTTIME SETBACK" TEMPERATURE

Default Settings:  TEMP (moon), "--" (OFF)



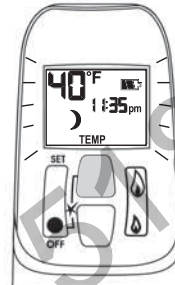

- Briefly press SET button to scroll to TEMP  (moon) mode. Hold the SET button until the TEMP flashes.

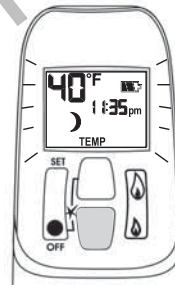

- Press  (large flame) button to increase  Nighttime Setback Temperature.



- Press  (small flame) button to decrease  Nighttime Setback Temperature.



- Press OFF or simply wait to complete programming.

#### Tip

Set the different parameters when they are flashing.

## Remote Control Operation

### SETTING PROGRAM TIMERS

- You can program two periods of time between 12:00 am and 11:50 pm in each 24-hour cycle.
- The Programs P1 and P2 must be set in the following order during a 24-hour cycle: **P1** ☀, **P1** 🌙, **P2** ☀ and **P2** 🌙
- The icon ☀ indicates the beginning of the period (ON) and the icon 🌙 indicates the end of the period (OFF).
- If **P1** ☀ = **P1** 🌙 or **P2** ☀ = **P2** 🌙, the programming is cancelled.
- To keep the fireplace ON all night, set **P2** 🌙 at 11:50 am and **P1** ☀ at 12:00 am.

#### Default settings:

Program 1: **P1** ☀ 6:00 am **P1** 🌙 8:00 am

Program 2: **P2** ☀ 11:50 pm **P2** 🌙 11:50 pm



- Briefly press SET button to scroll to TIMER mode.

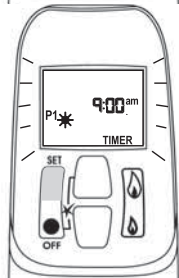

### SETTING P1 ON TIME

- Hold the SET button until **P1** ☀ (sun) is displayed and the time flashes.

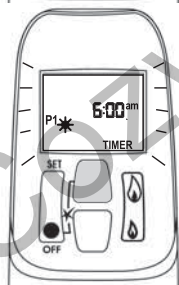

- Press 🔥 (large flame) button to set the hour.

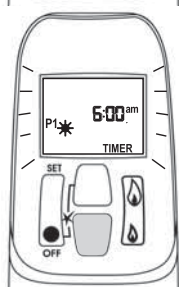

- Press 🔥 (small flame) button to set the minutes.

### SETTING P1 OFF TIME

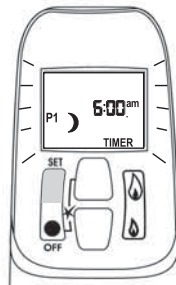

- Briefly press SET button to scroll to TIMER **P1** 🌙 (moon) while the time flashes.

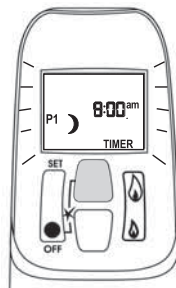

- Press 🔥 (large flame) button to set the hour.

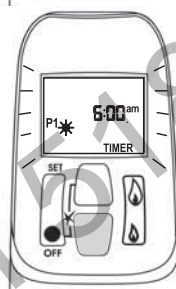

- Press 🔥 (small flame) button to set the minutes.

### SETTING P2 ON TIME

- Briefly press SET to scroll to TIMER mode **P2** ☀ (sun) while the time flashes.
- Follow the instructions given to set P1 ON time.

### SETTING P2 OFF TIME

- Briefly press SET to scroll to TIMER mode **P2** 🌙 (moon) while the time flashes.
- Follow the instructions given to set P1 OFF time.

Press OFF button to save these settings. The timers are programmed. See the diagram on programming sequences on the following page.

#### Tip

If you want to program only one period, program **P1** ☀ and **P1** 🌙 with desired times and program **P2** ☀ and **P2** 🌙 with the same time as **P1** 🌙.

## Remote Control Operation

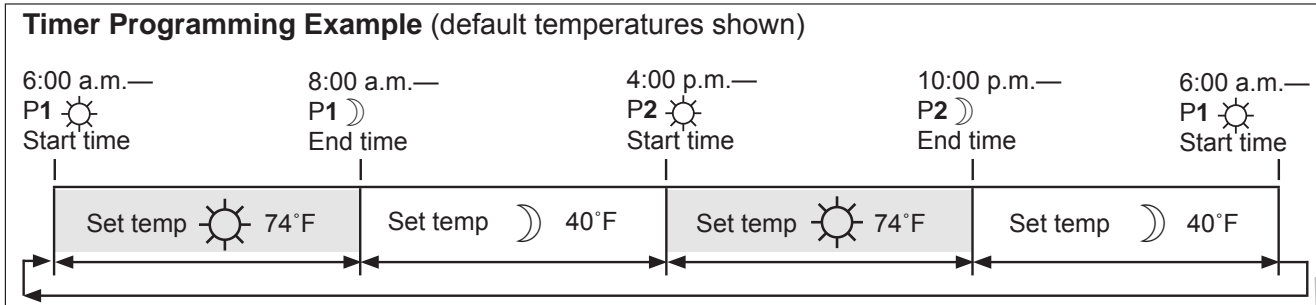

### AUTOMATIC TURN DOWN

- **No communication.** If there is no communication between the receiver and the handset for a period of 6 hours, the appliance goes into pilot mode.
- **No change in flame height.** If there is no change in flame height for a period of 6 hours, the appliance goes into pilot mode.  
**NOTE:** In **TEMP** or **TIMER** modes, the flame height will vary according to room temperature. The appliance will continue to work normally. However, if the room temperature remains the same for 6 hours, the appliance will go into pilot mode.

### AUTOMATIC SHUT OFF

- **Low batteries in the receiver.** With low battery power in the receiver the system shuts off completely.  
**NOTE:** This does not apply when the power supply is interrupted.
- **No change in pilot.** The appliance shuts off completely when it is continually in pilot position—without any change—for a period of 5 days.

### LOW BATTERY INDICATION

#### CAUTION

**DO NOT USE** a screwdriver or other metallic object to remove the batteries from the battery box or the handset! This could cause a short circuit.

**Remote handset:** The battery icon will show when the battery needs to be replaced.

Replace with one 9 V **alkaline** battery.

**Receiver:** Three short 'beeps' will sound when the motor turns when the batteries need to be replaced. Replace with four 1.5 V **alkaline** batteries.

### HANDSET / RECEIVER MATCH

The remote control handset and receiver are programmed to function together. In case of a replacement of the handset or the receiver, you will need to reset the receiver to allow them to function together. Contact your dealer for details.

## Wall Switch Operation

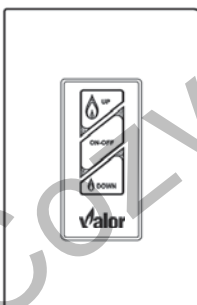

The Wall Switch can be used to control your fireplace. You can turn the pilot on or off and you can increase or decrease the flame height.

Note that the thermostat and programming functions are not available with the wall switch.

### TO TURN APPLIANCE ON and OFF

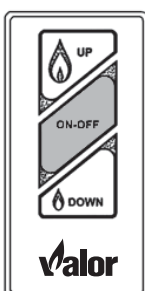

- Press ON-OFF button once to light pilot. Press again to shut of pilot.

### TO ADJUST FLAME HEIGHT

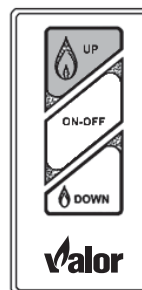

- Press and hold large flame button to gradually increase flame height.

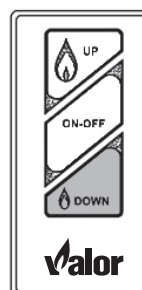

- Press and hold small flame button to gradually decrease flame height.

## Options

### Required Kits

**Liners** (choose one)

- 618EBL**—Enamel Black Liner (Steel)
- 620FBL**—Fluted Black Liner (Ceramic)
- 621VRL**—Valor Red Brick Liner (Ceramic)
- 622LSL**—Ledgestone Liner (Ceramic)

**Surrounds** (choose one)

- 660LSV**—Landscape Surround Vintage Iron
- 660LSB**—Landscape Surround Black
- 662SSV**—Square Surround Vintage Iron

**Inner Bezel** (choose one—required with Surround)

- 661BSB**—Inner Bezel Black
- 661BSN**—Inner Bezel Nickel
- 661BSC**—Inner Bezel Copper
- 661BSP**—Inner Bezel Polished

### Optional Kits

- 619RSK**—Rock Set Kit, to convert from logs to rocks.
- 671RGK**—Rock and Glass Kit, to convert existing rocks.

### **755CFK**—Circulating Fan Kit

Having variable speed and temperature control, it is designed to boost the natural convection process through the appliance. It may be fitted before the fireplace is installed or retrofitted at a later date provided power is available.

NOTE: The power supply to the fan should be controlled by a wall switch to allow convenient ON/OFF control of the fan.

### **650NGK**—Natural Gas Conversion Kit

For conversion from propane to natural gas. Intended primarily for post installation conversion in areas where natural gas was not available at the time of initial installation.

### **650PGK**—Propane Gas Conversion Kit

For conversion from natural gas to propane gas.

### **Hearth Gate (optional)**

Hearth gates such as Cardinal's VersaGates are available at retail stores carrying safety products for children.

## Lighting Instructions

## FOR YOUR SAFETY, READ BEFORE LIGHTING

**WARNING: If you do not follow these instructions exactly, a fire or explosion may result causing property damage, personal injury or loss of life.**

- A. This appliance has a pilot which must be lighted by hand, remote control, or wall switch. Follow these instructions exactly. To save gas, turn the pilot off when not using the appliance for a prolonged period of time.
- B. **BEFORE LIGHTING**, smell all around the appliance area for gas. Be sure to smell next to the floor because some gases are heavier than air and will settle on the floor.
- WHAT TO DO IF YOU SMELL GAS**
- Do not try to light any appliance.
  - Do not touch any electric switch; do not use any phone in your building.
  - Immediately call your gas supplier from a neighbor's phone. Follow the gas supplier's instructions.
  - If you cannot reach your gas supplier, call the fire department.
- C. Use only your hand to push in or turn the control knobs. Never use tools. If the knobs will not push in or turn by hand, don't try to repair them; call a qualified service technician. Force or attempted repair may result in a fire or explosion.
- D. Do not use this appliance if any part has been under water. Immediately call a qualified service technician to inspect the appliance and to replace any part of the control system and any gas control, which has been under water.

## LIGHTING INSTRUCTIONS

1. **STOP!** Read the safety information above.
2. **TO CLEAR ANY GAS**, turn main valve off by pressing OFF (red dot) button on remote handset (1).
  - Wait five (5) minutes to clear out any gas, then smell for gas, including near the floor. **If you smell gas, STOP!** Follow "B" in the safety information above on this label. If you don't smell gas, go to the next step.
3. **AUTOMATIC IGNITION:** MAN-knob (2) in ON position. Ensure Flame Adjustment knob (3) is set to lowest setting (∩) (Fig. 1). Locate the pilot (Fig. 3.) inside of firebox at left hand side.
  - On the remote control handset, press the OFF button (red dot) and large flame button (🔥) simultaneously; a short acoustic signal confirms the start has begun.
  - Further short acoustic signals indicate the ignition process is in progress.
  - When the pilot is lit, the Flame Adjustment knob (3) will automatically rotate to the highest setting.
  - Press the small flame button (🔥) on the remote control handset to reduce the flame height.
4. **MANUAL IGNITION:** MAN-knob (2) in MAN position (Fig. 2). With the window off, locate the pilot (Fig. 3) inside of firebox at left hand side.
  - Set Flame Adjustment knob (3) to the lowest setting (∩).
  - Push down the metallic core (4) with a pen or similar instrument; this will establish the pilot gas flow.
  - Light gas at the pilot (5) with a match.
  - Continue holding down metal core (4) for about 10 seconds; after release, pilot should remain lit.
    - If the pilot will not stay lit after several tries, turn the gas control knob (3) to OFF (∩) and call your local service technician or gas supplier.
  - Reinstall the window and set the MAN-knob (2) to ON; turn Flame Adjustment knob (3) up (∪) or down (∩) manually or use the flame buttons (🔥) (🔥) buttons on the remote control handset to adjust the flame height.

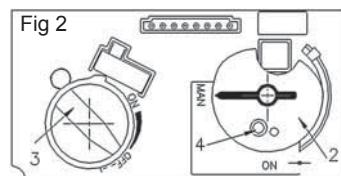
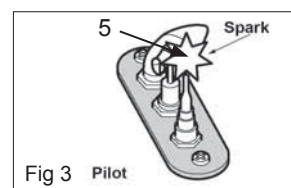
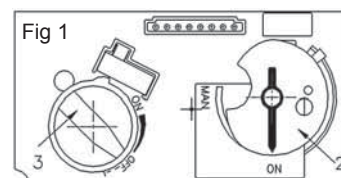
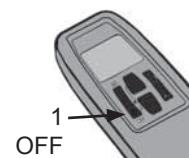

## TO TURN OFF GAS TO APPLIANCE

**AUTOMATIC SHUT-OFF** (using the remote control handset):

- Press and hold the small flame button (🔥) on the remote control handset to shut-off the main burner gas flow.
- Press OFF button (red dot) on remote handset to shut-off the appliance, including pilot flame.

**State of Massachusetts Carbon Monoxide  
Detector/Vent Terminal Signage  
Requirements**

For all side wall horizontally vented gas fueled equipment installed in every dwelling, building or structure used in whole or in part for residential purposes, including those owned or operated by the Commonwealth and where the side wall exhaust vent termination is less than seven (7) feet above finished grade in the area of the venting, including but not limited to decks and porches, the following requirements shall be satisfied:

**1. INSTALLATION OF CARBON MONOXIDE DETECTORS.** At the time of installation of the side wall horizontal vented gas fueled equipment, the installing plumber or gas fitter shall observe that a hard wired carbon monoxide detector with an alarm and battery back-up is installed on the floor level where the gas equipment is to be installed. In addition, the installing plumber or gas fitter shall observe that a battery operated or hard wired carbon monoxide detector with an alarm is installed on each additional level of the dwelling, building or structure served by the side wall horizontal vented gas fueled equipment. It shall be the responsibility of the property owner to secure the services of qualified licensed professionals for the installation of hard wired carbon monoxide detectors.

a. In the event that the side wall horizontally vented gas fueled equipment is installed in a crawl space or an attic, the hard wired carbon monoxide detector with alarm and battery back-up may be installed on the next adjacent floor level.

b. In the event that the requirements of this subdivision can not be met at the time of completion of installation, the owner shall have a period of thirty (30) days to comply with the above requirements; provided, however, that during said thirty (30) day period, a battery operated carbon monoxide detector with an alarm shall be installed.

**2. APPROVED CARBON MONOXIDE DETECTORS.** Each carbon monoxide detector as required in accordance with the above provisions shall comply with NFPA 720 and be ANSI/UL 2034 listed and IAS certified.

**3. SIGNAGE.** A metal or plastic identification plate shall be permanently mounted to the exterior of the building at a minimum height of eight (8) feet above grade directly in line with the exhaust vent terminal for the horizontally vented gas fueled heating appliance or equipment. The sign shall read, in print size no less than one-half (1/2) inch in size, "GAS VENT DIRECTLY BELOW. KEEP CLEAR OF ALL OBSTRUCTIONS".

**4. INSPECTION.** The state or local gas inspector of the side wall horizontally vented gas fueled equipment shall not approve the installation unless, upon inspection, the inspector observes carbon monoxide detectors and signage installed in accordance with the provisions of 248 CMR 5.08(2)(a)1 through 4.

(b) **EXEMPTIONS:** The following equipment is exempt from 248 CMR 5.08(2)(a)1 through 4:

1. The equipment listed in Chapter 10 entitled "Equipment Not Required To Be Vented" in the most current edition of NFPA 54 as adopted by the Board; and
2. Product Approved side wall horizontally vented gas fueled equipment installed in a room or structure separate from the dwelling, building or structure used in whole or in part for residential purposes.

(c) **MANUFACTURER REQUIREMENTS - GAS EQUIPMENT VENTING SYSTEM PROVIDED.** When the manufacturer of Product Approved side wall horizontally vented gas equipment provides a venting system design or venting system components with the equipment, the instructions provided by the manufacturer for installation of the equipment and the venting system shall include:

1. Detailed instructions for the installation of the venting system design or the venting system components; and
2. A complete parts list for the venting system design or venting system.

(d) MANUFACTURER REQUIREMENTS - GAS EQUIPMENT VENTING SYSTEM NOT PROVIDED.

When the manufacturer of a Product Approved side wall horizontally vented gas fueled equipment does not provide the parts for venting the flue gases, but identifies “special venting systems”, the following requirements shall be satisfied by the manufacturer:

1. The referenced “special venting system” instructions shall be included with the appliance or equipment installation instructions; and

2. The “special venting systems” shall be Product Approved by the Board, and the instructions for that system shall include a parts list and detailed installation instructions.

(e) A copy of all installation instructions for all Product Approved side wall horizontally vented gas fueled equipment, all venting instructions, all parts lists for venting instructions, and/or all venting design instructions shall remain with the appliance or equipment at the completion of the installation.

CozyCabin.com 518-623-4349

## Specifications

### Approvals & codes

These appliances are certified by ANSI Z21.88-2009/CSA 2.33-2009 American National Standard / CSA Standard for *Vented Gas Fireplace Heaters* for use in Canada and USA. These appliances are for installation directly venting through an outside wall or through the roof.

Models 650ILN/IRN are for use with natural gas.

Models 650ILP/IRP are for use with propane gas.

Conversion between fuels may only be done using the approved conversion kits listed in the section *Options*.

These appliances comply with CSA P4.1-09 *Testing method for measuring annual fireplace efficiencies*.

The installation must conform with local codes or, in the absence of local codes with the *National Fuel Gas Code, ANSI Z223.1* or the *Natural Gas and Propane Installation Code CAN/CGA-B149*. Only qualified licensed or trained personnel should install these appliances.

These appliances, when installed, must be electrically grounded in accordance with local codes or, in the absence of local codes, with the *National Electrical Code, ANSI/NFPA 70* or the *Canadian Electrical Code, CSA C22.1*.

### Ratings

Model	ILN/IRN	ILP/IRP
Gas	Natural	Propane
Altitude (Ft.)	0-4,500 *	
Input Max. (Btu/h)	24,000	24,000
Input Min. (Btu/h)	6,500	13,000
Manifold pressure (in. w.c.)	3.95	10.5
Min. Supply pressure (in. w.c.)	5.0	11.0
Max. Supply pressure (in. w.c.)	11.0	14.0

\*Tested to *CGA - 2.17-91 High Altitude Standard in Canada*. In the USA, installations may require deration over 2000 feet—check local codes.

### \*High Altitude Installations

Input ratings are shown in BTU per hour and are certified without deration for elevations up to 4,500 feet (1,370 m) above sea level.

For elevations above 4,500 feet (1,370 m) in USA, installations must be in accordance with the current ANSI Z223.1 and/or local codes having jurisdiction. Heating value of gas in some areas is reduced to compensate for elevation—consult your local gas utility to confirm.

For installations at elevations above 4,500 feet (1,370 m) in Canada, please consult provincial and/or local authorities having jurisdiction.

### Supply Gas

Heater engine units 650ILN/IRN are used with natural gas installations.

Heater engine units 650ILP/IRP are used with propane gas installations.

The supply pressure must be between the limits shown in the table above.

The supply connection is  $\frac{3}{8}$  inch NPT.

The opening for the gas supply line is at the left side of the appliance.

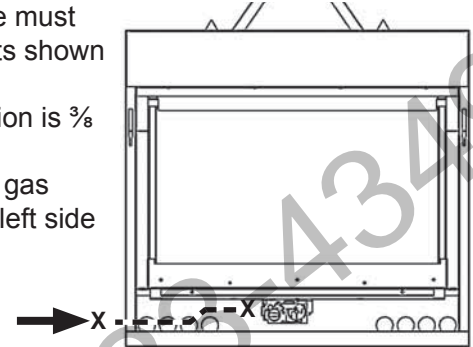

### Wall Thickness

The vent system (when horizontally terminated) is approved to pass through combustible wall construction of up to 14 inches (36 cm) thick.

A non-combustible wall can be any thickness up to the maximum horizontal run of vent pipe allowed for the particular installation—see *Venting* section.

### Venting options

#### Direct vent installations (solid piping)

A list of all approved venting accessories is shown on pages 43–44 of this manual.

NOTE: An 817VAK Vent Adapter is required in all cases when using vent components other than Valor's 551DVK Standard Vent Terminal.

#### Direct Vent Co-Linear Installations (flexible piping)

Converts the appliance outlet collars to accept two 3-inch diameter flex liners for installation into existing solid-fuel burning fireplaces and chimneys. Requires a co-linear adapter at the appliance and either a co-linear terminal or co-linear-to-co-axial adapter and terminal at the top of the chimney. A list of approved venting accessories is shown on pages 43–44 of this manual.

### Floor/Hearth

This appliance is approved for installation directly on combustible material such as plywood and so on. Vinyl, carpet, and soft flooring require sheet metal extending the whole width and depth under the appliance. This appliance does not require a hearth. Combustible flooring may extend up to the front of the unit.

Overview

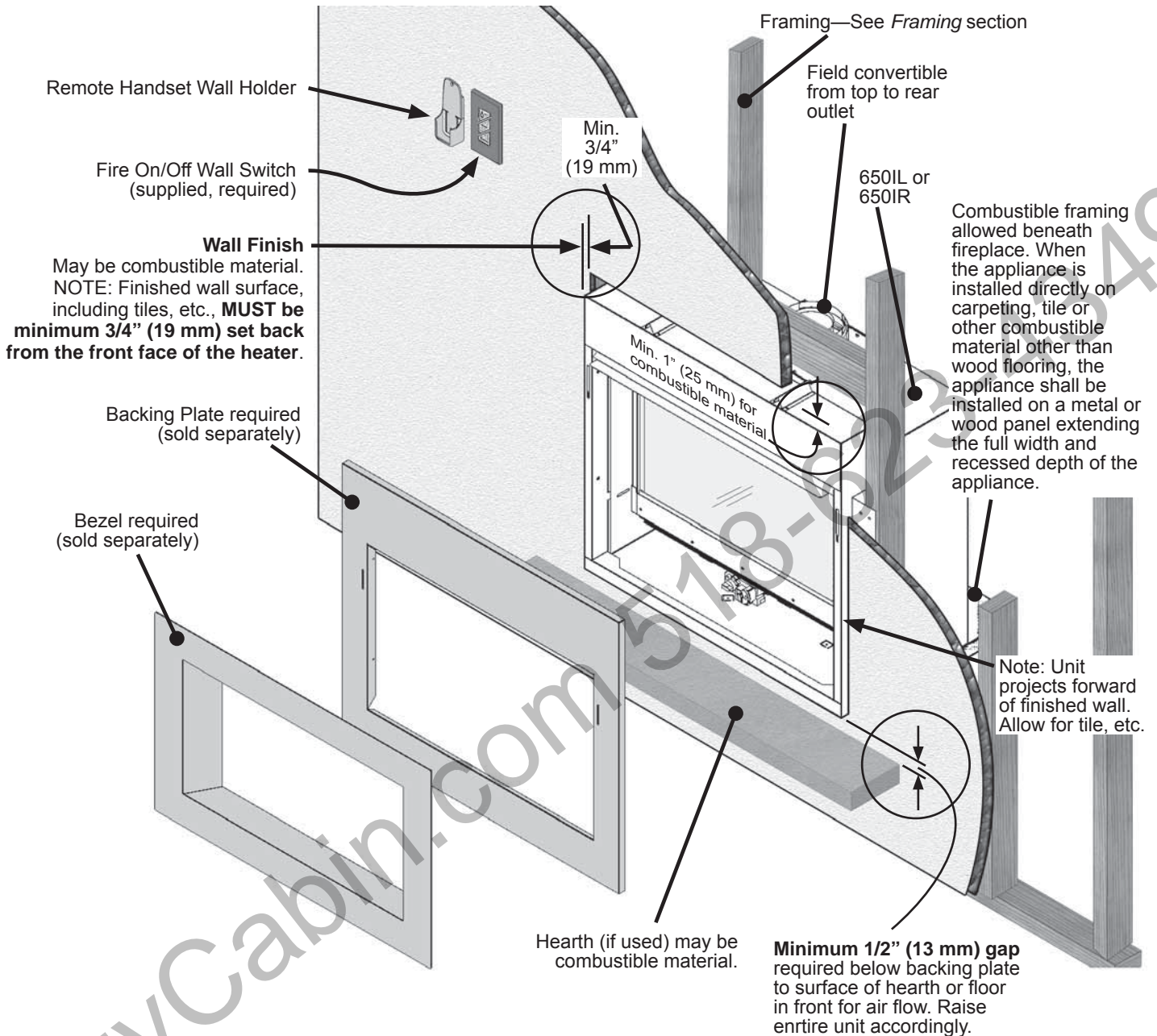

**⚠ WARNING**

Some materials or items, although safe, may discolor, shrink, warp, crack, peel, and so on because of the heat produced by the fireplace. Avoid placing candles, paintings, photos, and other items sensitive to heat around the fireplace.

**⚠ WARNING**

**HOT HEARTH / FLOOR!** The hearth or floor in front of the fireplace may become very hot when the fireplace heats. Do not use the hearth as a seat or shelf. Solid wood flooring in front of the fireplace (if allowed) may shrink during the heating season due to heat.

## Dimensions

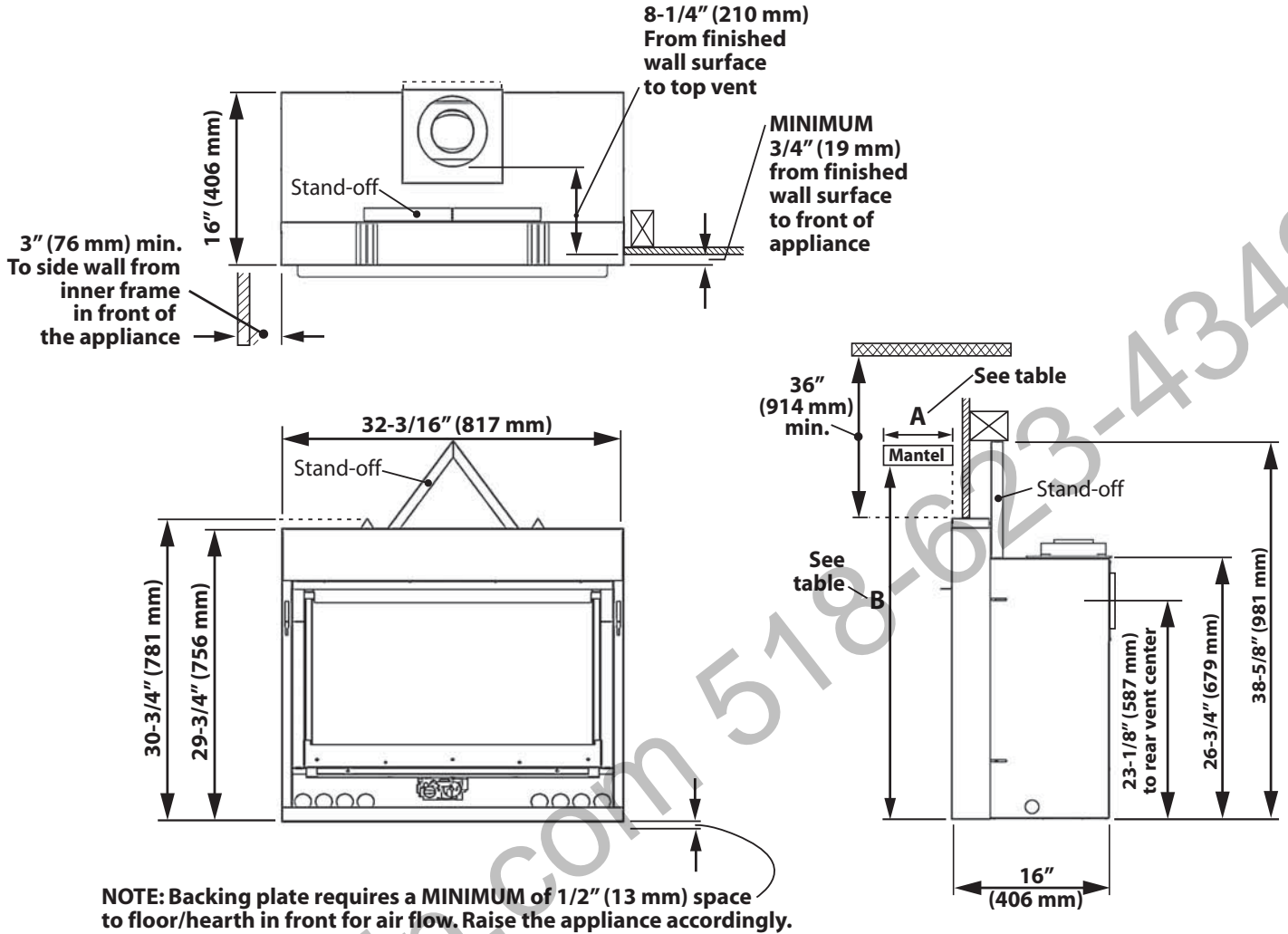

Mantel depth "A"	0-2" (0-51 mm)	2-4" (51-102 mm)	4-6" (102-152 mm)	6-8" (152-203 mm)	8-10" (203-254 mm)	10-12" (254-305 mm)
Mantel height "B"	31-1/4" (794 mm)	34" (864 mm)	35" (889 mm)	36" (914 mm)	37" (940 mm)	38" (965 mm)

For fronts and trims dimensions, refer to instructions provided with the fronts and trims.

# Framing

- A non-combustible hearth is not necessary in front of this appliance.
- Note that the unit is installed at the framing stage and fixed to framing using support angles. See page 31. The wall finish is then installed over the support angles up to the front frame on the unit, on the sides and up to the stand-offs on the top.

When the appliance is installed directly on carpeting, tile or other combustible material other than wood flooring, the appliance shall be installed on a metal or wood panel extending the full width and depth of the appliance.

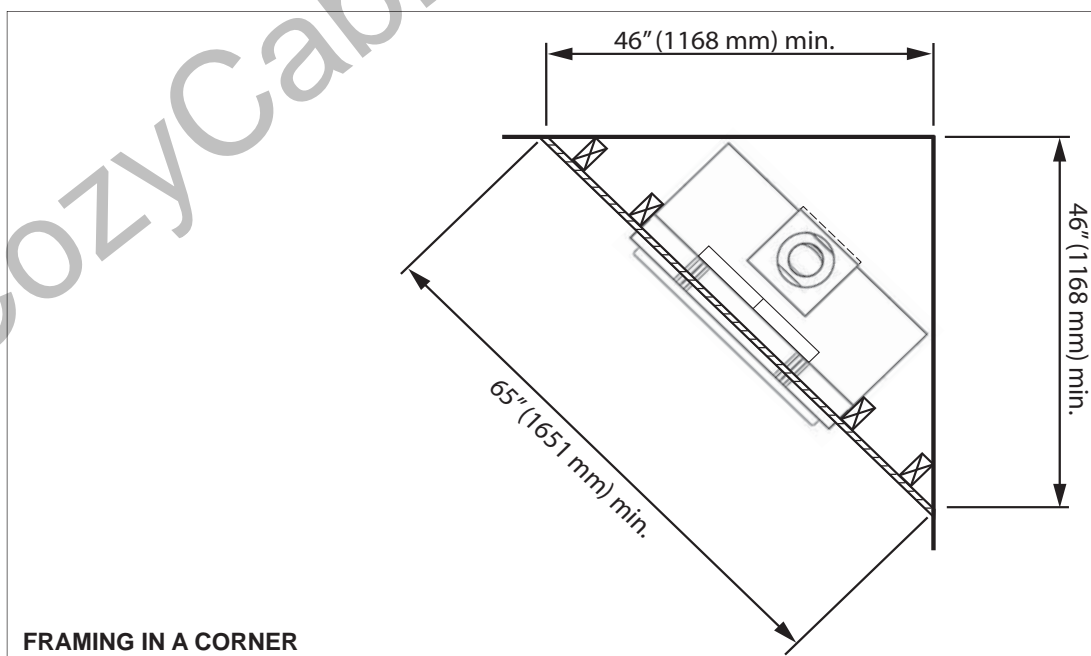
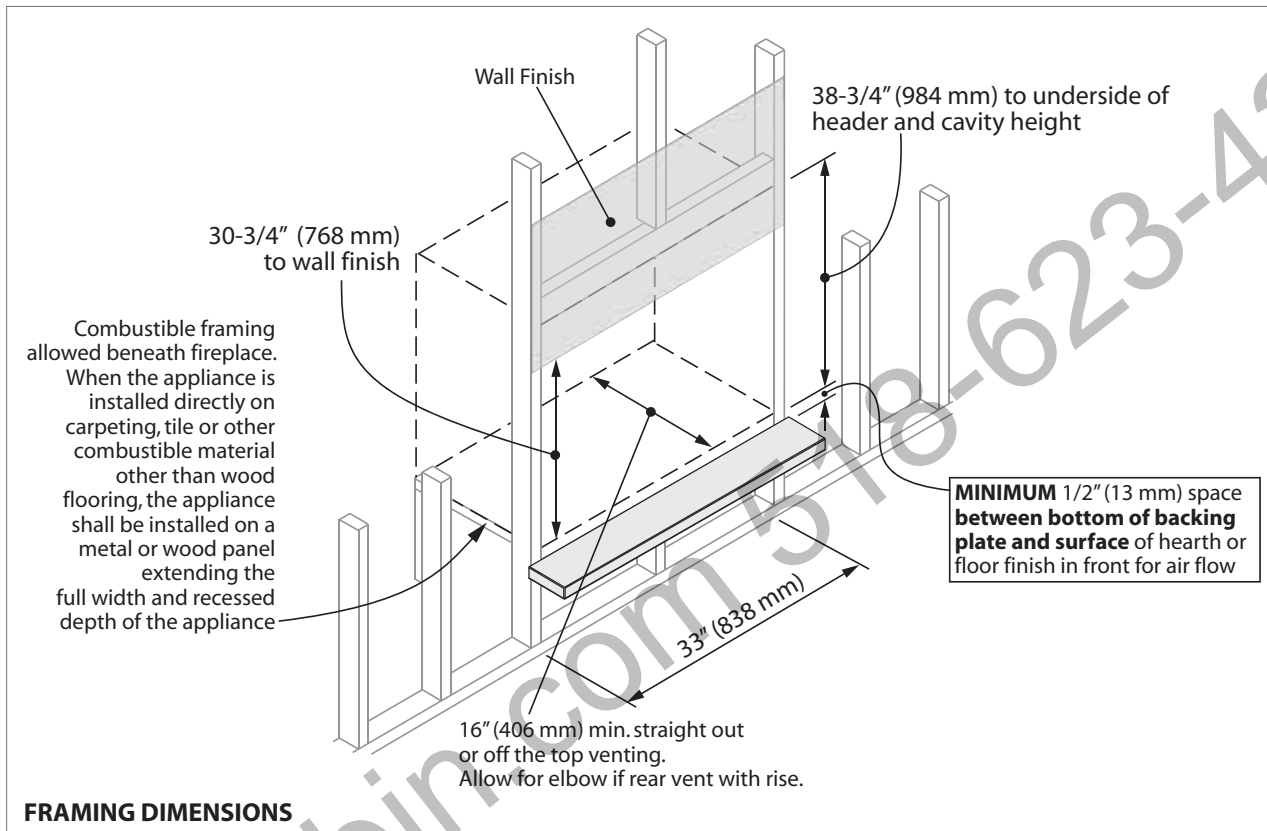

## Location

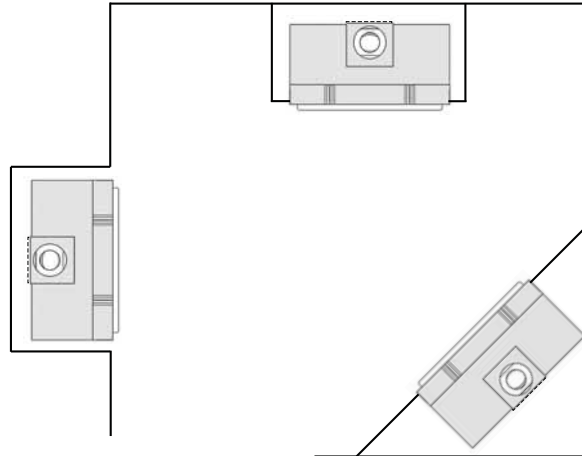

## Venting

### Vent Material

This unit is approved for installation using 4 by 6-5/8 inches diameter approved co-axial direct vent pipes and accessories listed on pages 43–44 of this guide. Follow the installation instructions supplied with the individual venting accessories.

This unit may also be converted to co-linear venting with two 3-inch pipes for use in solid-fuel burning fireplaces and chimneys using approved adapters and accessories listed on pages 43–44 of this guide.

### Wall Thickness

The appliance vent is suitable for penetrating a combustible wall assembly up to 14 inches in thickness. A non-combustible wall can be of any thickness up to the maximum horizontal run of vent pipe allowed for the particular installation.

### Vent Sealing

Seal all outer coaxial pipe and elbow joints, including sectioned elbow joints, using high quality, high temperature 2 inch wide self-adhesive aluminum foil tape (Nashua-322-2 brand or similar). Wrap the tape completely around all joints and press firmly to seal.

A high temperature black silicone sealant may be used in the outer joints as a substitute to foil tape.

Ensure all the pipe joints have a minimum of 1 ¼ inch overlap.

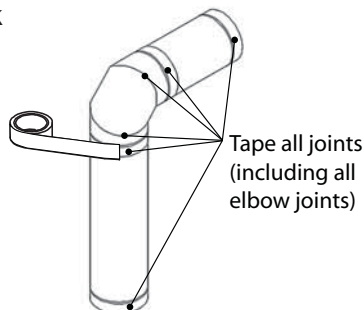

### Vent Penetration through Walls & Ceilings

**Combustible:** When penetrating through combustible walls and ceilings, frame a minimum of 10 inch by 10 inch opening and ensure that the insulation is kept clear of the vent pipe using either a wall shield or thimble or an attic insulation shield. Follow the installation instructions supplied with the individual venting components.

**Non-combustible:** If the wall is totally non-combustible (e.g. masonry block or concrete), mark for a 7 inch circular hole.

In both cases, the center of the hole should line up with the center line of the horizontal vent.

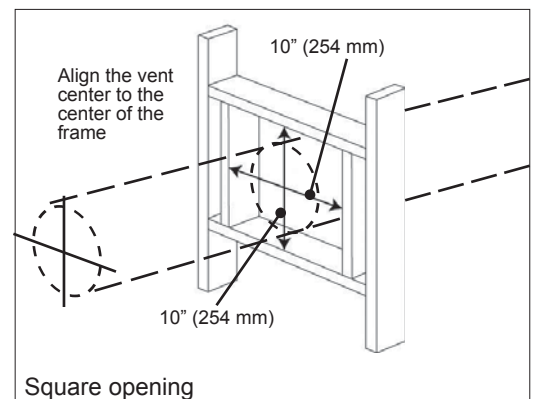

## Typical Co-Axial Venting Components

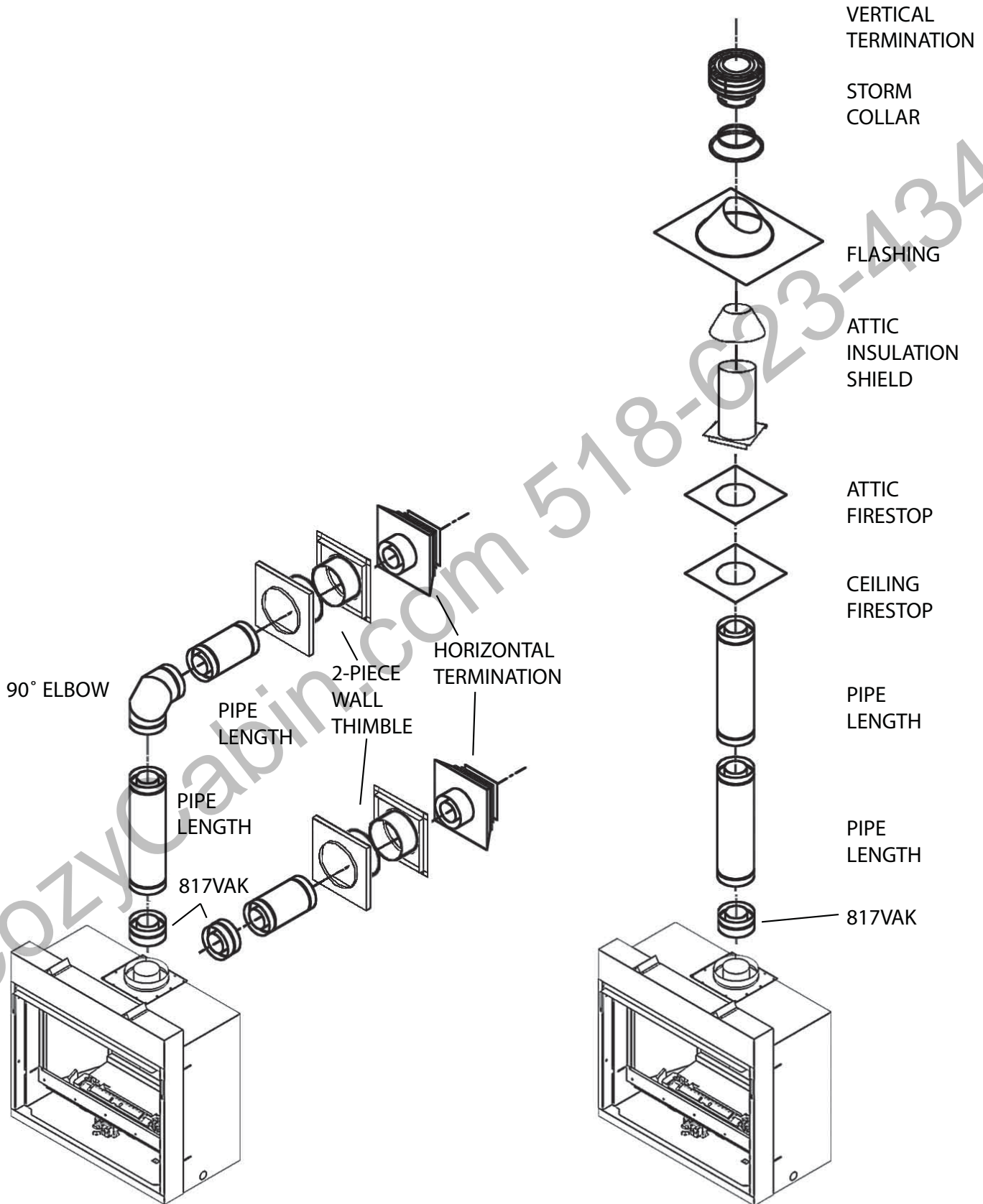

## Co-Axial Venting

### Co-Axial Venting Rear Vent with No Vertical Rise

The horizontal vent run cannot be extended by the use of any vent accessory pipes.

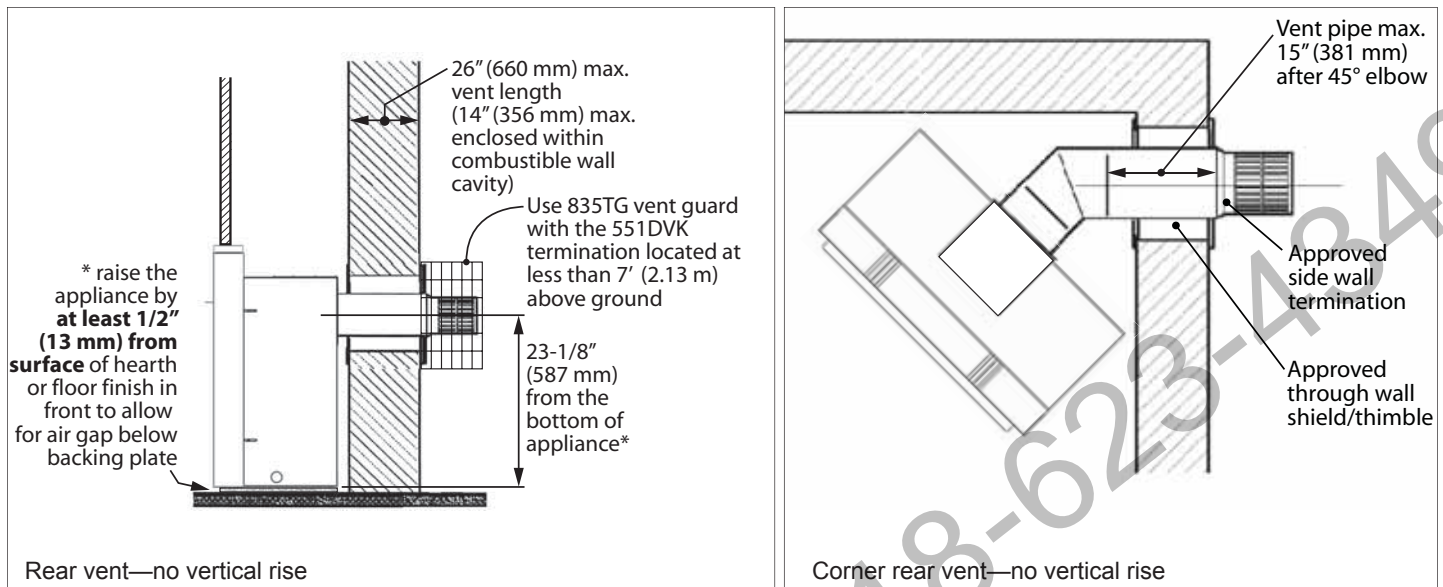

### Important Installer Notice – Weather Sealing & Vapor Barriers

It is the installer's responsibility to ensure that vent installations through exterior walls are caulked and weatherproofed in such a manner as to:

- Prevent rain water from entering the wall from the weather side by adequately caulking the outer vent plate to the exterior wall surface.
- Prevent moisture inside the home from penetrating into the wall structure by ensuring the inside wall plate is adequately sealed to the inside vapor barrier.
- Prevent rain water and moisture from entering the walls by sealing the joints between the outer vent tube and the inner and outer wall plates.

We recommend the use of a high quality polyurethane sealant.

## Horizontal Vent Termination Location

- The vent terminal must be located on an outside wall or through the roof.
- This direct vent appliance is designed to operate when an undisturbed airflow hits the outside vent terminal from any direction.
- The minimum clearances from this terminal that must be maintained when located on an outside wall are shown in figure below. Any reduction in these clearances could result in a disruption of the airflow or a safety hazard. Local codes or regulations may require greater clearances.
- The vent terminal must not be recessed into a wall or siding.
- The vent terminal should be positioned where any snowdrifts will not cover it.
- 551DVK sidewall vent termination requires the terminal guard 835TG when accessible—within 7' of ground.

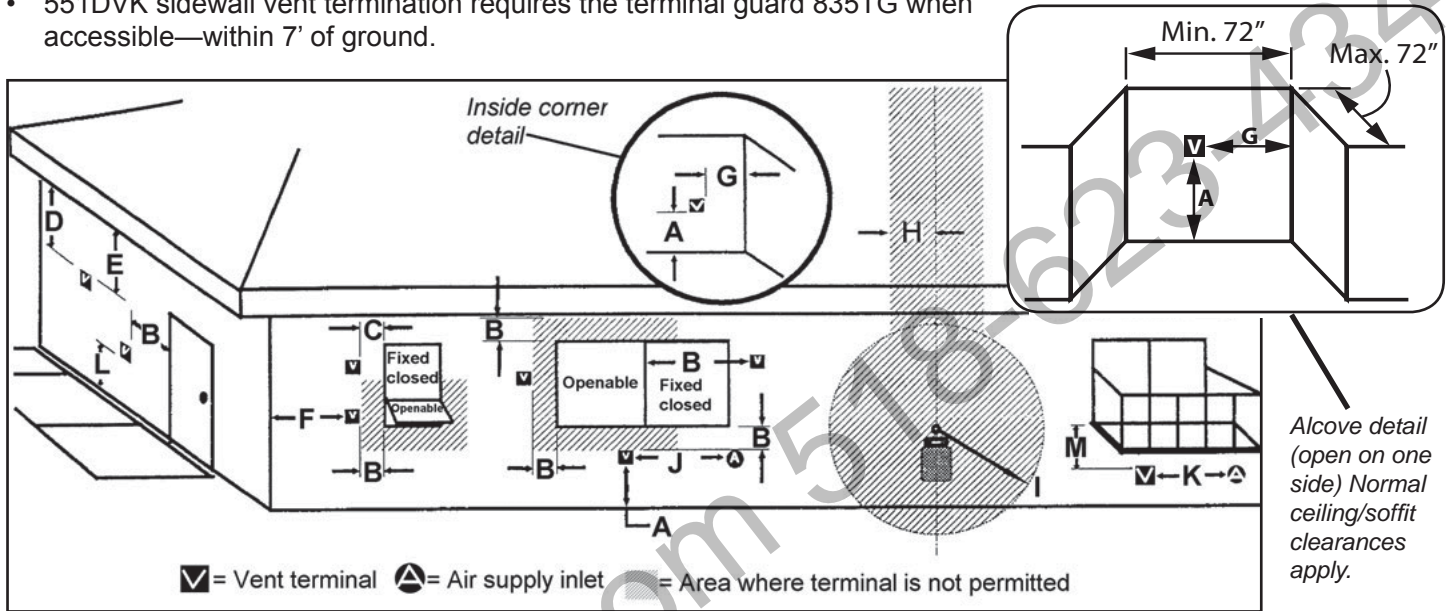

KEY	VENT TERMINAL LOCATIONS - MINIMUM DISTANCES	MINIMUM CLEARANCE	
		Inches	Cm
A	Clearance above grade, verandah, porch, deck or balcony	12	30
B	Clearance to window or door that may be opened	12	30
C	Clearance to permanently closed window (recommended to prevent condensation on window)	12	30
D	Vertical clearance to ventilated soffit located above the terminal within a horizontal distance of 2 feet (60 cm) from the center-line of the terminal	18	46
E	Clearance to unventilated soffit	12	30
F	Clearance to outside corner	12	30
G	Clearance to inside corner	12	30
H	Horizontal clearance to center-line of meter/regulator assembly located within 15 feet (4,6 m) below the terminal	36	90
I	Clearance to service regulator vent outlet	36	90
J	Clearance to non-mechanical air supply inlet to the building or the combustion air inlet to any other appliance	12	30
K	Clearance to a mechanical air supply inlet	72	180
L	Clearance above paved sidewalk or a paved driveway located on public property <b>Note:</b> A vent must not terminate directly above a sidewalk or paved driveway, which is located between two single-family dwellings and serves both dwellings	84	210
M	Clearance under a verandah, porch, deck or balcony Only permitted if veranda, porch, deck or balcony is fully open on a minimum of 2 sides beneath the floor	12	30

Note: Local codes and regulations may require different clearances.

# Co-Axial Venting

## Co-Axial Venting Configurations with Vertical Rise

4 x 90° ELBOWS MAXIMUM  
(or equivalent)

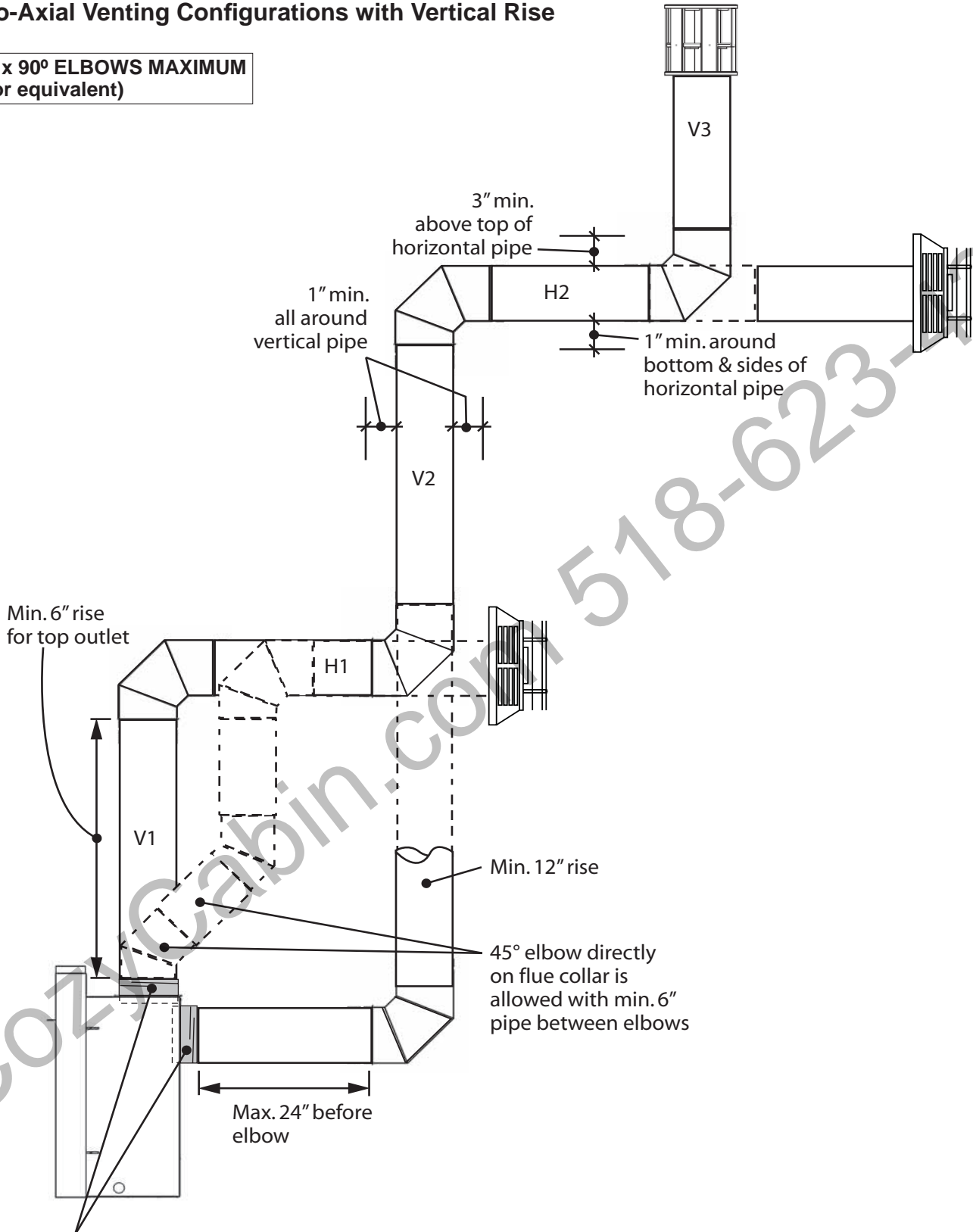

817VAK adapter:  
required for top outlet;  
required for rear outlet **except**  
when connecting the 551DVK  
terminal directly to the appliance.

**Example 1**  
 $V \text{ Value} = V1 (6') + V2 (6') + V3 (2') = 14'$   
 $H \text{ Value} = H1 (3') + H2 (3') = 6'$

# Co-Axial Venting

## How to Read the Venting Chart

The chart below applies to co-axial roof or wall termination in installations with vertical rise. See page 24 for installations with no vertical rise.

1. The total length of the vent pipe cannot exceed 40 feet (12.2 m).
2. The minimum vertical height with roof termination is 10 feet (3.05 m).
3. Any combination of rise and run can be used as long as they are within the allowable limits shown on the chart below.
4. A maximum of four 90 degrees elbows—or equivalent (2 x 45 degrees = 90 degrees)—can be used.
5. Each 90 degrees elbow installed on the horizontal plane is equivalent to a 3 feet horizontal pipe; therefore, 3 feet must be subtracted from allowable horizontal run. (45 degrees elbow is equivalent to 18 inches horizontal pipe.)
6. All horizontal pipe runs must be graded 1/4 inch per foot upwards in the direction of the exhaust flow. The final pipe length, when terminating through the wall may be graded downwards slightly to prevent water migration.
7. Maximum co-linear venting is 40 feet (12.2 m).
8. A restrictor is required for all installations—see section *Appliance Preparation* section for more information.

## Venting Chart—Allowable Co-Axial Vent Configurations with Vertical Rise

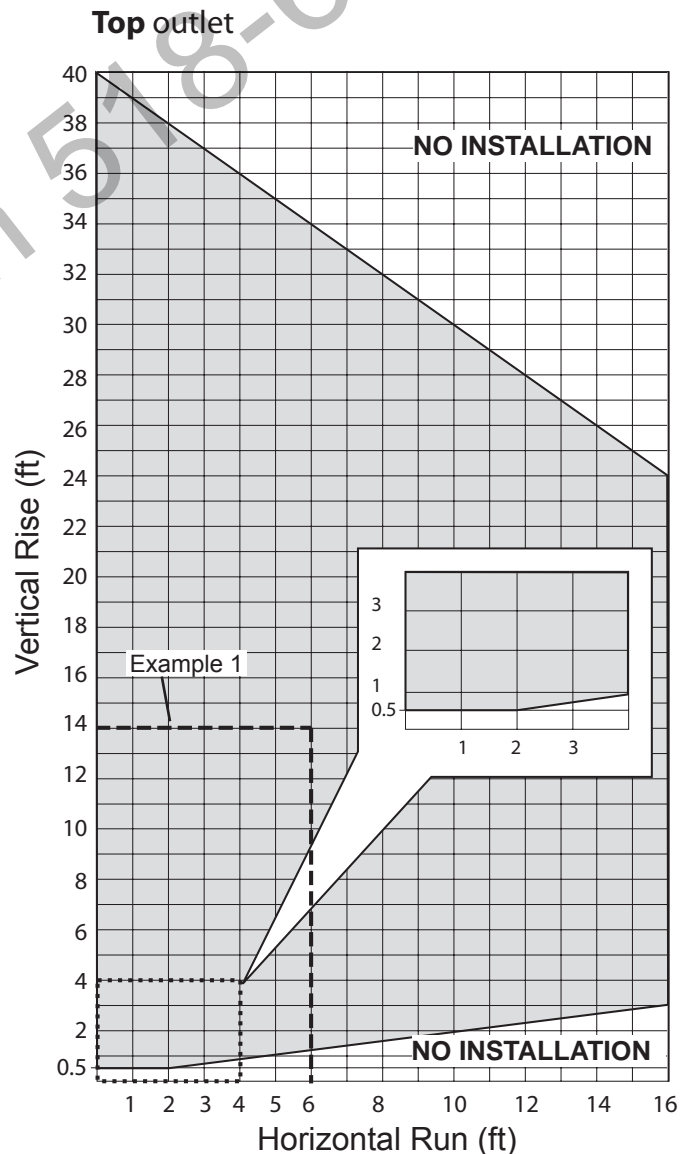
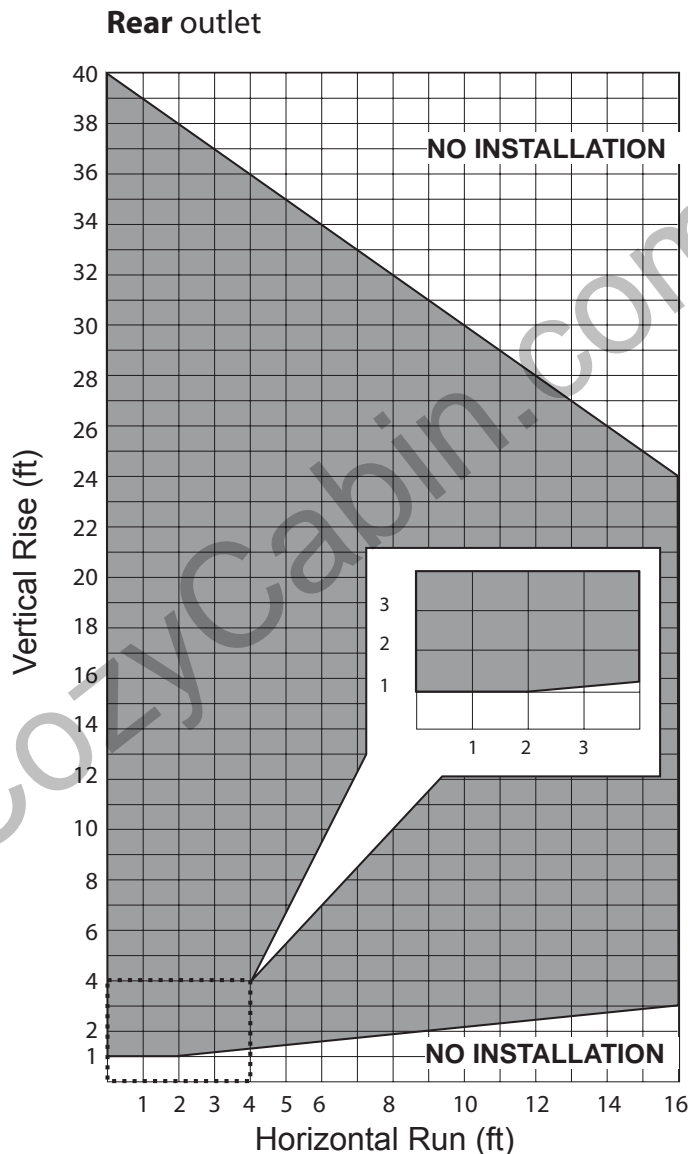

## Co-Axial Venting

### Co-Axial Vertical Installations

- Check the roof pitch to determine which roof flashing will be needed. See venting accessories list on pages 43–44 for allowable components.
- The distance from the roof to the lowest terminal discharge opening (“H” in figure) depends on the roof pitch and must be in accordance with the manufacturer’s instructions supplied with the termination unit.

*Note: The venting system for these appliances is considered to be a **Special Venting System**. The rule in the Installation Code requiring a minimum vent height of 2 feet above any portion of a building within 10 feet does not therefore apply.*

- The minimum clearances to combustible materials all round the vent pipes must be in accordance with the dimensions shown in the *Co-Axial Venting* section of this manual.
- Drop a plumb from the ceiling to the center of the appliance vent opening. Mark the position on the ceiling. Drill a small hole at the marked position.
- Determine the position where the vent will pass through the roof. If directly above the position where it penetrates the ceiling, drop a plumb from the roof to the small hole in the ceiling and mark the roof at this spot.

If rafters or other obstructions will prevent a vertical exit or if clear attic space is desired, the roof outlet can be offset using 45 degree elbows. Drill a small hole at the marked position.

- A ceiling firestop must be installed at the second floor and higher floors. A ceiling support should be used below the flat ceiling. To install the firestop and support, cut and frame a 10 inches (254 mm) square hole centered on the small hole previously drilled.
- Fit vent accessory elbows and pipe lengths as required up through ceiling support boxes and firestops.
- If installation includes offset, support the offsetting pipes every 3 feet (1 m) with wall straps as shown.
- Cut a hole in the roof centered on the small hole. The hole must allow for the minimum clearances to combustible materials. See *Venting* section in this manual.
- Fit pipe lengths through the roof. Fit roof flashing securing it with roofing nails.
- Fit storm collar and termination cap.

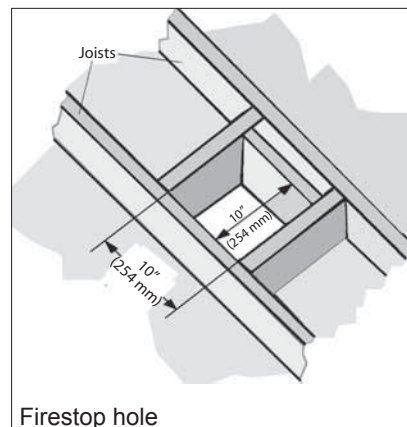
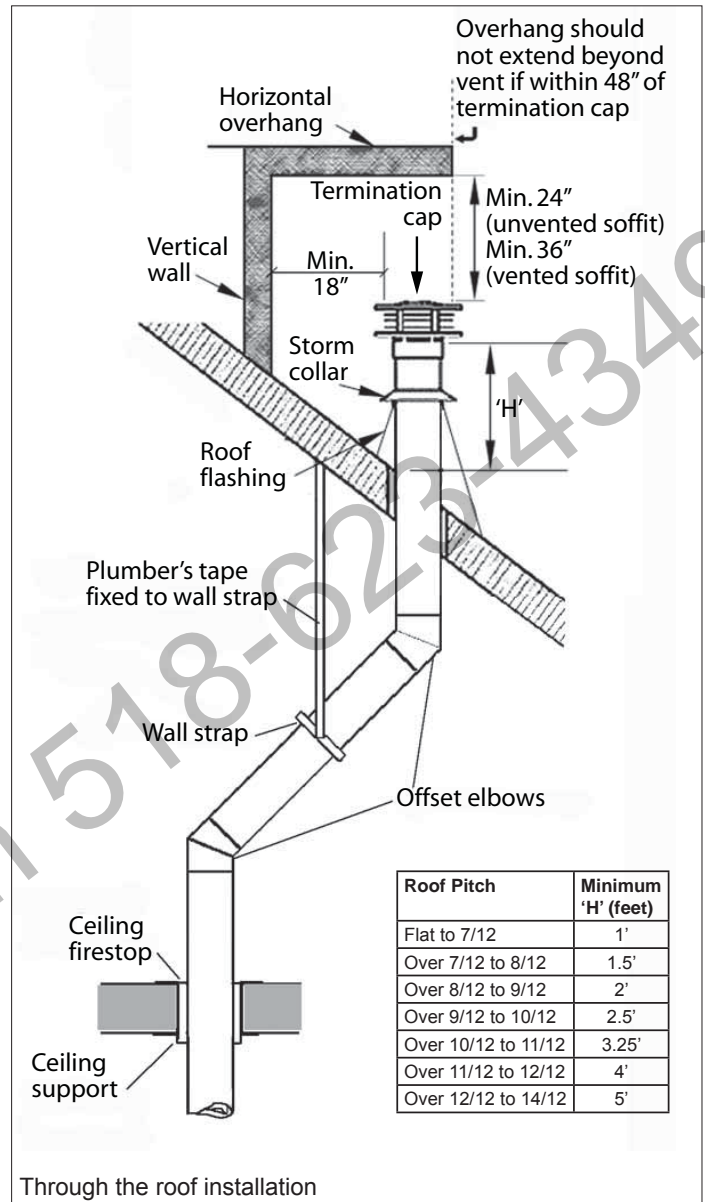

# Co-Linear Venting

## Co-Linear Vent Installations

- The fireplace dimensions are shown in the *Dimensions* section of this manual.
- Place the appliance (fitted with the co-linear adapter) near the fireplace opening but allow space for manipulating the chimney liners on to the appliance.
- Drop the 3-inch diameter flexible liners into the chimney from outside.
- Fit the liners to the co-linear adapter paying attention to inlet and exhaust and move the appliance to its proper position. Be aware of the minimum liner bend radius and maximum liner horizontal run shown on page 27 of this manual.
- Fit the termination kit and flashing to the exterior of the chimney.

Secure the appliance to the floor or wall if necessary.

## Rear or Top Outlet Conversion to Co-Linear Liners using Valor 556CLA Co-Linear Adapter. (Generic co-axial to co-linear adapter boxes may also be used as an alternate to the 556CLA).

Only for use when retrofitting a solid-fuel burning fireplace and chimney.

The appliance must not be connected to a chimney flue serving a separate solid-fuel burning appliance.

Requires 556CLA Co-Axial to Co-Linear Appliance Adapter (or, alternatively, a generic adapter), two lengths of 3-inch diameter flexible chimney liner, co-linear termination kit and flashing and either high wind vertical vent terminal cap or a low profile vertical termination.

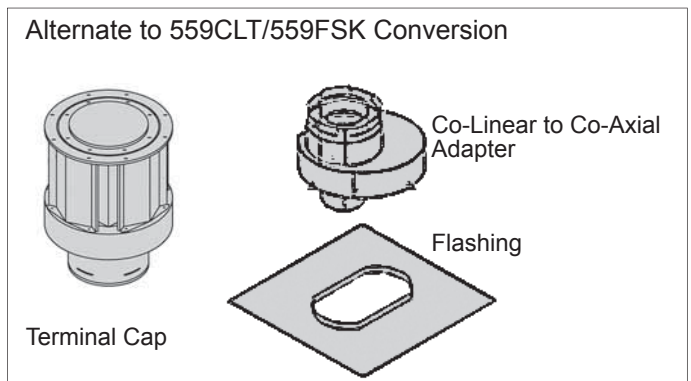
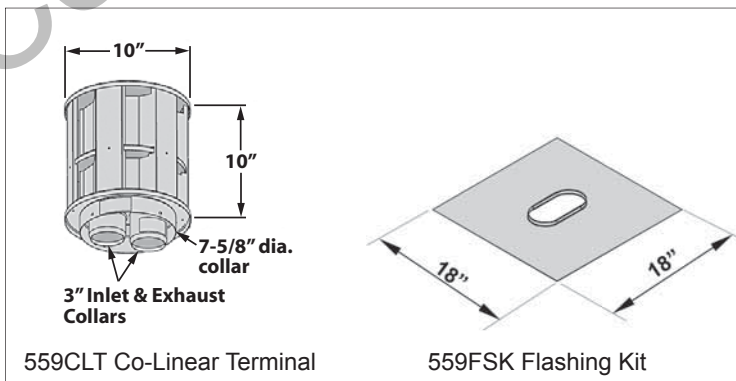
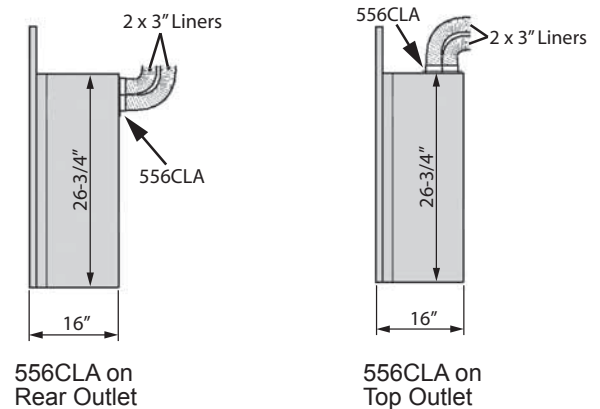
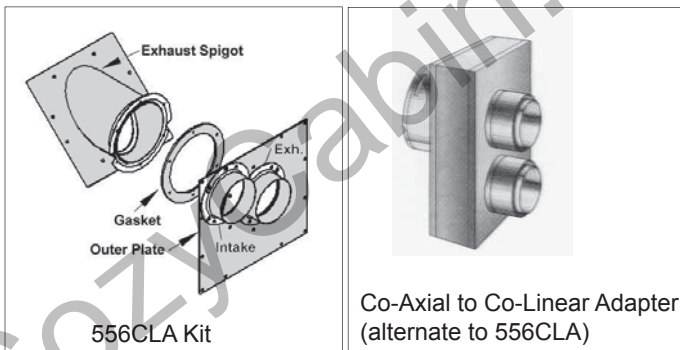
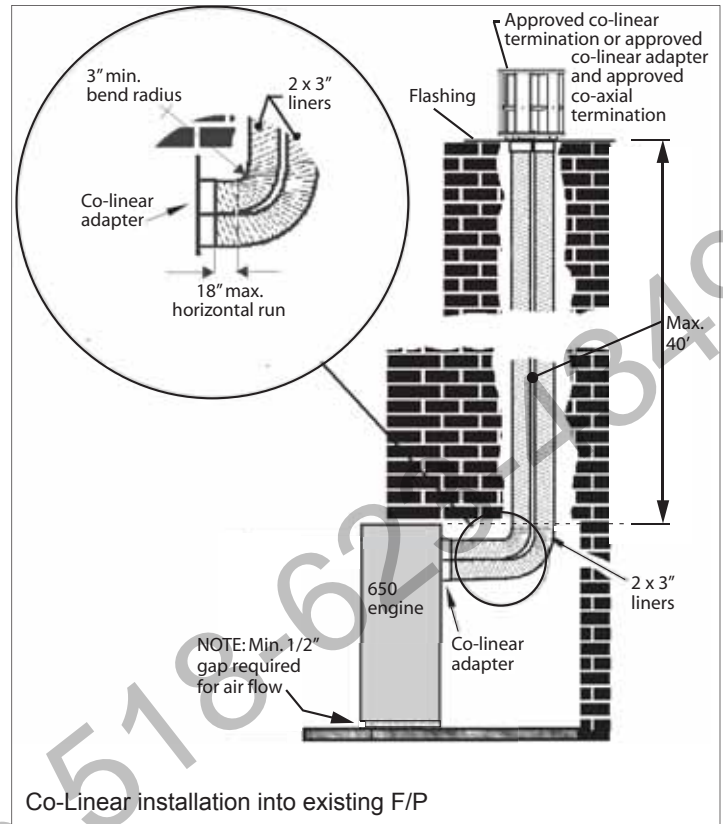

## Window Removal

1. Turn the top two spring-loaded window bolts through 90 degrees to release the window from the firebox.
2. Remove the bottom two spring-loaded window bolts.
3. Carefully lift the window away. Keep the window and bolts in a safe place.

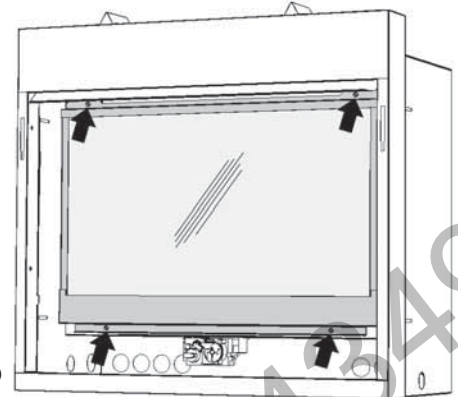

## Rear Vent Outlet Positioning

*If installing with top vent outlet, ignore this stage.*

*If installing co-linear venting, see instructions supplied with the co-linear adapter.*

1. Remove the rear outlet cover plate and seal by unscrewing 12 screws. Keep the seal and plate for fitting to the top.
2. Remove the top outer vent collar and seal by unscrewing 12 screws.
3. Remove the top inner vent collar and seal by unscrewing 8 screws.
4. Locate the inner collar and seal inside the rear outlet opening. Secure the inner collar with 8 screws.
5. Fit the outer collar over inner collar. Loosely fit the 12 screws. Place the adapter 817VAK or Valor terminal kit 551DVK over the collars to check alignment. Tighten the 12 screws to secure the outer collar.
6. Fit the cover plate and seal (removed from the rear) to the top vent opening with 12 screws.

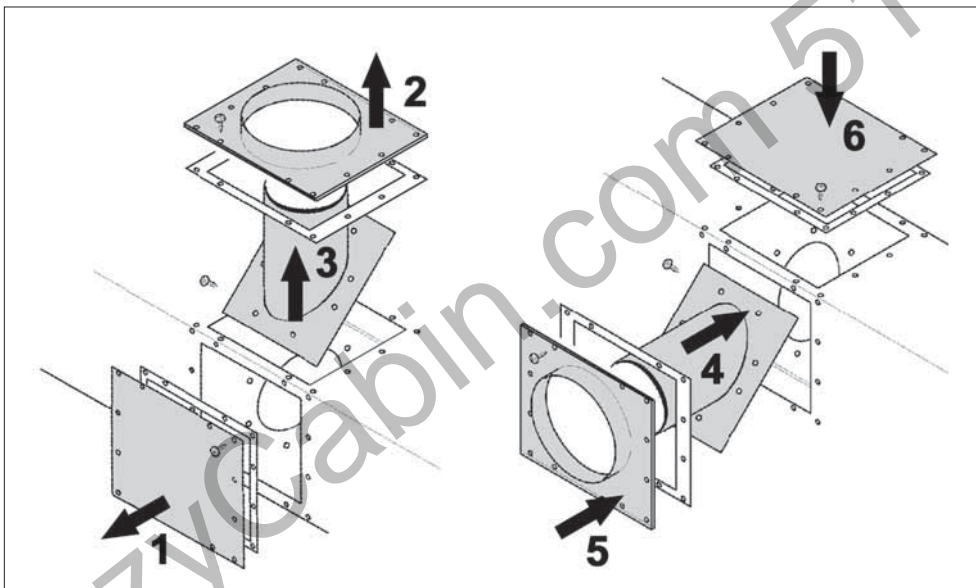

## 817VAK Vent Adapter Fitting

*If rear venting with Valor terminal unit 551DVK, ignore this stage.*

1. Fit the adapter 817VAK over the appliance vent collars pushing on firmly.
2. For rear vent outlet connection, align the adapter so that the seam on horizontal pipes is not at the bottom—check by temporarily fitting a pipe.
3. Drill through the adapter outer tube and appliance outer collar for no. 6 screws. *Make sure that the drill does not penetrate the inner tubes.*
4. Secure the adapter to the outer collar with two no. 6 thread-cutting screws supplied.

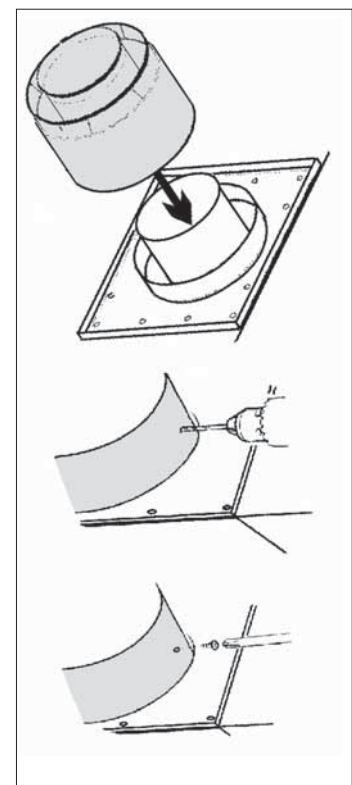

## Stand-off and Support Angles Installation and Fitting

The distance from the support angles to the front face of the heater case is adjustable to allow for a range of wall finish material thickness (e.g. tile, etc.).

1. Check the wall finish requirements with the homeowner.
2. Secure the side support angles from the inside of the appliance using two screws provided. Set back the support angles from the front of the appliance by the thickness of the wall finish + 3/4" (19 mm) for projection.
3. Remove two screws from the rear of the appliance's frame top.
4. Bend the 12-inch stand-off and fix it to the appliance case with the two screws just removed as indicated.
5. Place the appliance in position in the framing.
6. Secure the appliance to the studs.  
Note: The support angles screws may be loosened later from the inside of the appliance to make final adjustments.

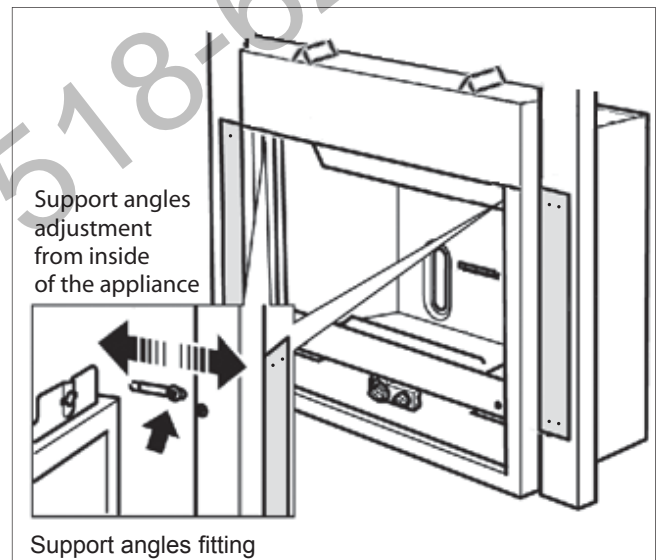
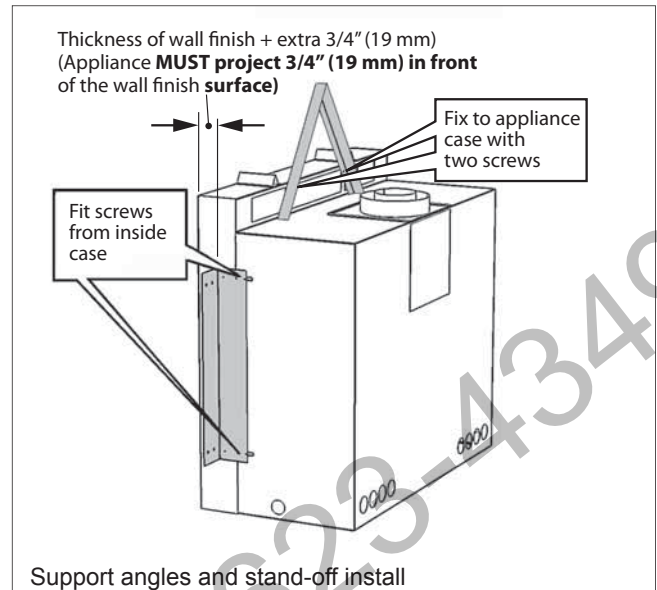
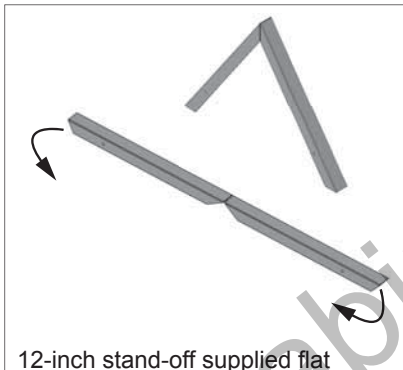

## Rear Log Support Removal

Remove the rear log support to access to the rear orifices for restrictors installation (5 screws).

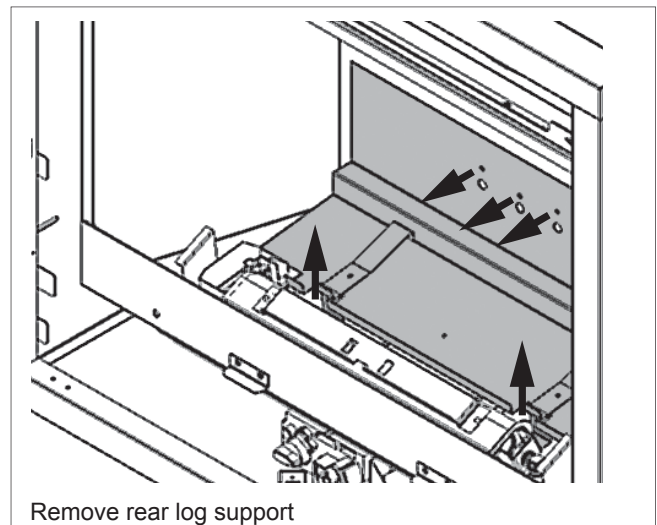

# Appliance Preparation

## Air Restrictors Fitting

**No restrictors are required for appliances which only have a horizontal vent run. If installing an appliance which has a rear vent outlet connection and no vertical vent pipe rise, ignore this stage.**

Two restrictor sets, like the one shown at right, are supplied with each 650 engine unit. The restrictors cover part of the **inlet air openings** in the firebox **rear wall** behind the rear log support. **Do NOT install the restrictors in the roof of the firebox!**

Each restrictor set includes an adjustable piece which can be moved to different positions depending of the vent configuration. See the table below to find out which position is optimal for each type of installation.

- To fit the restrictors, loosen the two center screws of the left and right inlet ports. Place the restrictor assembly under the screw heads and tighten the center screws.
- To set the adjustable restrictor piece, loosen the two screws, position the adjustable piece according to the diagram below and tighten the screws.

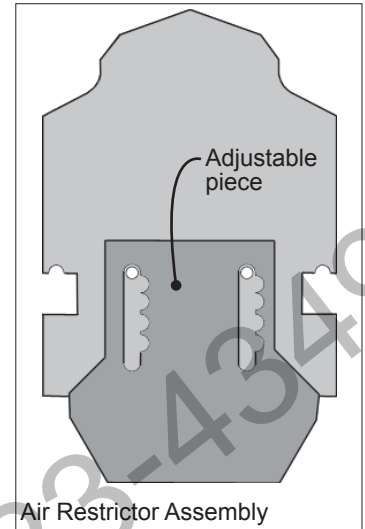

Vent terminal	Appliance vent outlet	Vertical vent pipe run	Use restrictor setting
Horizontal through wall with vertical rise	Top or Rear	Less than 6' (1.83 m)	
		From 6' (1.83 m) to 20' (6.1 m)	
		From 20' (6.1 m) to 40' (12.2 m)	

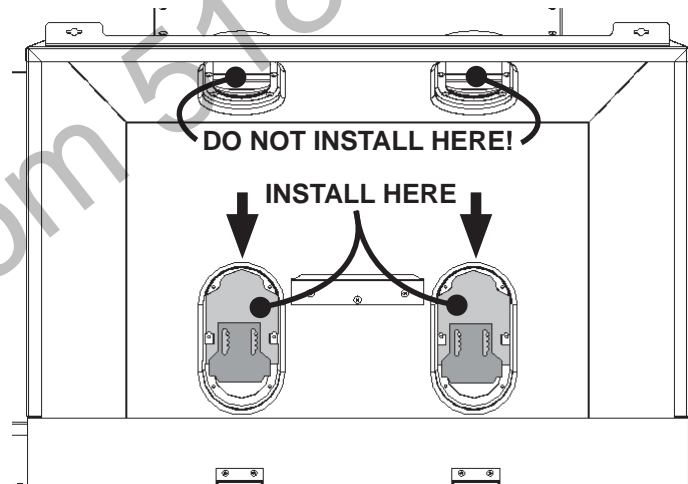

Vent terminal	Appliance vent outlet	Vertical vent pipe run	Use restrictor setting
Vertical through roof	Top or rear	Less than 20' (6.1 m)	
		From 20' (6.1 m) to 40' (12.2 m)	

## Rear Log Support Refitting

Refit the rear log support in place (5 screws).

## Gas Supply Installation

- The gas supply pipe should enter the appliance case through the opening at the left side. The supply pipe should be connected to the appliance gas inlet pipe situated at the left side of the control valve. Supply line connection to the inlet pipe is 3/8 inch NPT (female).

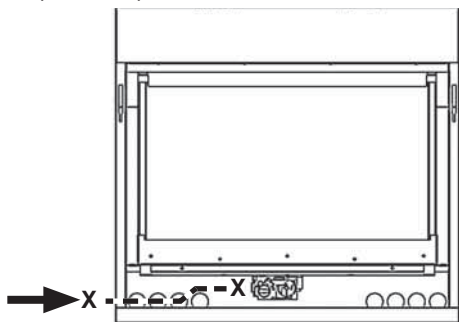

**If the circulating fan is to be installed, be aware that the supply pipe run inside the case should be at the same height as the appliance inlet pipe in order to clear the fan. If intending to fit an internal isolating valve, check that it will be clear of the fan.**

- Use only new black iron or steel pipes or copper tubing if acceptable—check local codes. **Note that in USA, copper tubing must be internally tinned for protection against sulfur compounds.**
- Unions in gas lines should be of ground joint type.
- The gas supply line must be sized and installed to provide a supply of gas sufficient to meet the maximum demand of the appliance without undue loss of pressure.
- Sealant used must be resistant to the action of all gas constituents including propane gas. Sealant should be applied lightly to male threads to ensure excess sealant does not enter gas lines.
- The supply line should include a *manual shut-off valve* to allow the appliance to be disconnected for servicing.
- A plugged 1/8 inch NPT tapping must be installed in the line. The tapping must be accessible for test gauge connection and be immediately upstream of the gas supply connection to the appliance.
- Pressure test the supply line for leaks.
  - » **The appliance and its individual shut-off valve must be disconnected from the gas supply piping system during any pressure testing of that system at test pressures in excess of 1/2 psig (3.5kPa).**

- » **The appliance must be isolated from the gas supply piping system by closing its individual manual shut-off valve during any pressure testing of the gas supply piping system at test pressures equal to or less than 1/2 psig (3.5kPa).**

- » Failure to either disconnect or isolate the appliance during pressure testing may result in regulator or valve damage. Consult your dealer in this case.

- The minimum supply pressure is given in the *Specifications* section of this manual.
- All piping and connections must be tested for leaks after installation or servicing. All leaks must be corrected immediately.
- When testing for leaks:
  - » Make sure that the appliance is turned off.
  - » Open the manual shut-off valve.
  - » Test for leaks by applying a liquid detergent or soap solution to all joints. Bubbles forming indicate a gas leak. **Never use an open flame to check for leaks.**
  - » Correct any leak detected immediately.
- The pressure test tapping locations are shown on below. A built-in non-adjustable regulator controls the burner manifold pressure. The correct pressure range is shown in the table in *Specifications* section of this manual. The pressure check should be made with the burner alight and at its highest setting. See *Lighting Instructions* section for full operating details.

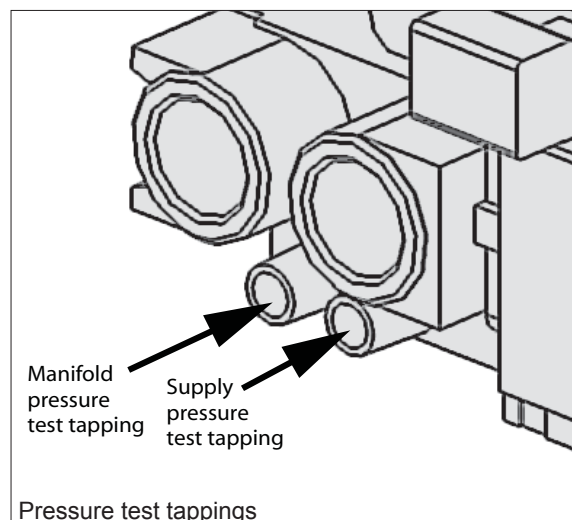

## Liner Panels Installation

All liner panels can be installed as indicated below. Unpack the liners carefully to avoid scratching or damaging them.

1. Place the rear panel against the back of the firebox on the ledge of the rear log support. Make sure the bevel part is at the top.

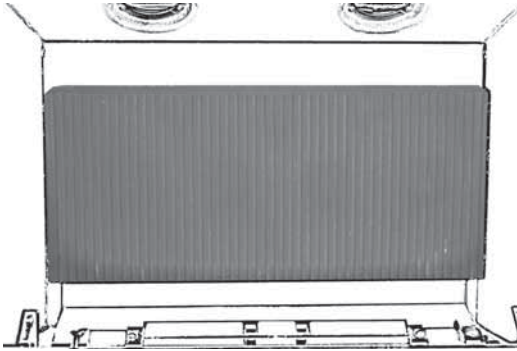

2. Hold the left hand side panel at an angle and insert its bottom edge inside the firebox. Rotate the panel to a vertical position ensuring that the top edge is behind the flange of the firebox. Pull the panel as far forward as possible against the left edge of the firebox.

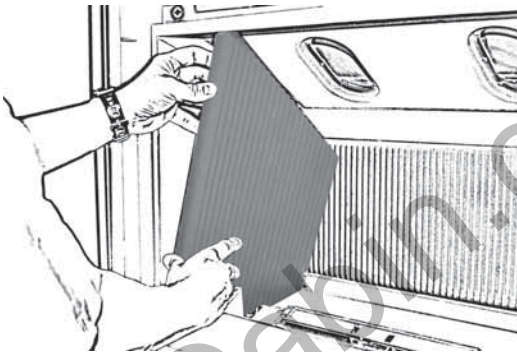

3. Hold the right hand side panel at an angle and insert its bottom edge inside the firebox. Rotate the panel to a vertical position ensuring that the top edge is behind the flange of the firebox. Pull the panel as far forward as possible against the right edge of the firebox.

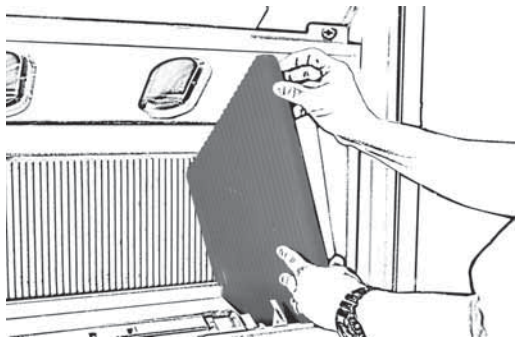

4. Insert the top panel over the left side panel while holding the top panel forward up the slope. Rotate the right side of the top panel upwards and place it over the top of the right panel. Slide the top panel down the slope of the firebox as far as possible to close the gap with the rear panel and to maximize the gap above the front edge of the top panel.

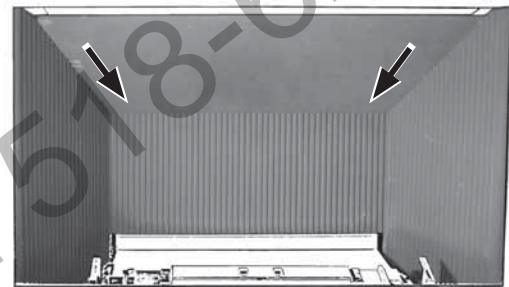
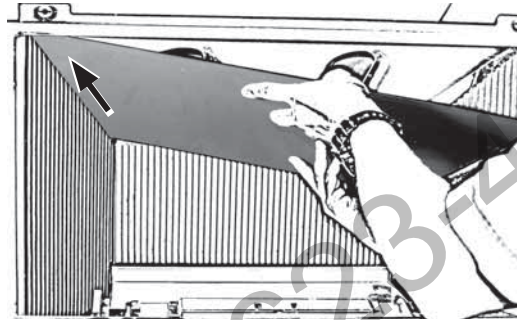

# Ceramic Logs Installation (650IL)

**QUALIFIED  
INSTALLER**

Unpack the ceramic logs very carefully to avoid damaging their fragile material. Install the logs as shown below. **Please note that the position of the logs is critical to insure the good performance of the appliance.**

1. Place the rear log centering it side to side in the firebox. Pull it forward until it sits against the sheet metal tabs behind the burner. The log will be inclined forward.

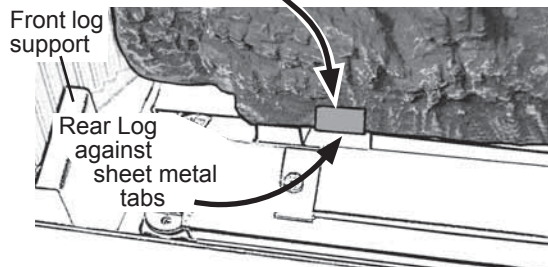

2. Place the front left log on top of the burner with its front edge resting slightly on the window frame.

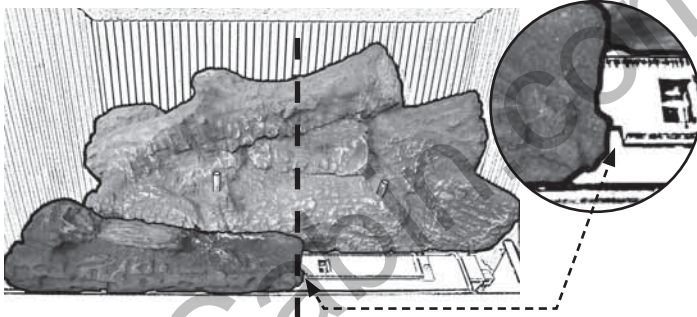

3. Place the front right log on the top of the burner with its left end abutted to the front left log and its front edge resting slightly on the window frame. **Center the front logs side to side in relation to the firebox.**



4. Identify the right cross log; it has a hole under one of its ends and it is the shortest cross log. Place it on the right pin located on the rear log. Rest its other end in the crook of the front right log.

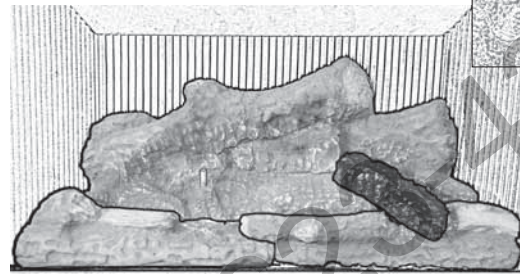

5. Identify the middle cross log. It does not have a hole underneath. Place its narrow end on the flat depression in the rear log next to the right cross log on the rear log. Place its wider end on the front log.



6. Identify the left cross log; it has a hole under its narrow end. Place its narrow end on the pin located on the rear log. Rest its wider end on the crook in the front left log at an angle of approximately 30 degrees from the center line of the fireplace to allow for the flame to come up in front of the rear log.



## Ceramic Rocks Installation (650IR)

Unpack the ceramic rocks kit very carefully to avoid damaging the fragile material. Install the components as shown below. Please note that **the position of the rocks and twigs (if used) is critical to ensure proper performance of the appliance.**

1. Install the Front Support Platform in the firebox carefully sliding it down between the burner and the front bottom edge for the firebox while avoiding scraping the side ceramic panels.

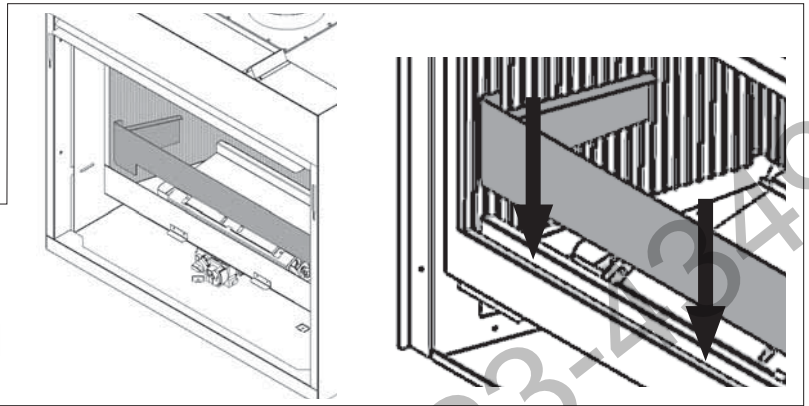
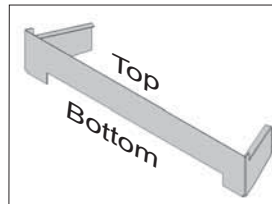

2. Place the rock ceramic base on the log support behind the burner. The front bottom of the base must rest against the vertical tab of the spacer brackets.

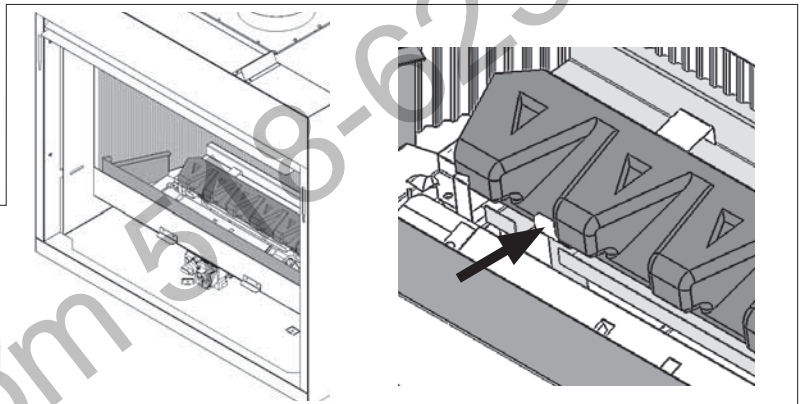
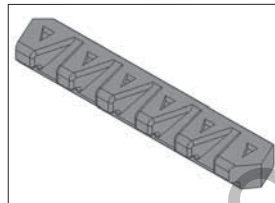

3. Install the ceramic platform in the firebox rotating down to insert the front first behind the Front Support. Lay the back of the ceramic platform against the rear ceramic panel again being careful not to scrape the ceramic panels.

**Warning: This platform is quite fragile. DO NOT force it in place.**

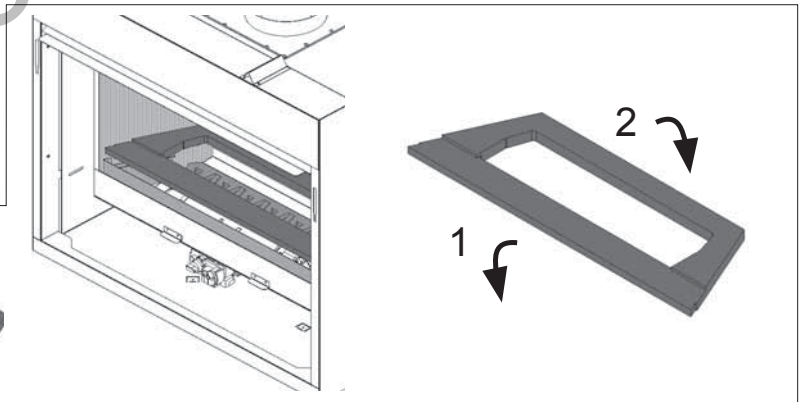

Fuel Bed Base  
Installed

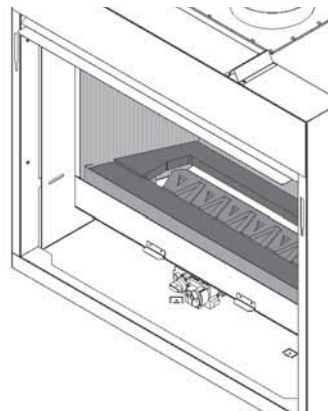

# Ceramic Rocks installation (650IR)

- 4. The underside of each ceramic rock is identified by a number and a specific protruding positioning triangle.

Install the six rocks from left to right starting with rock no. 1.

Note: The ceramic base may need to be slightly adjusted side-to-side to allow stones to fit within the platform.

A black discoloration may form over time at the front bottom of the 6-rock original fuel bed; this deposit can be burned off by running the fireplace on a low to medium setting fire for 30 to 45 minutes. This discoloration is unavoidable and will re-form again.

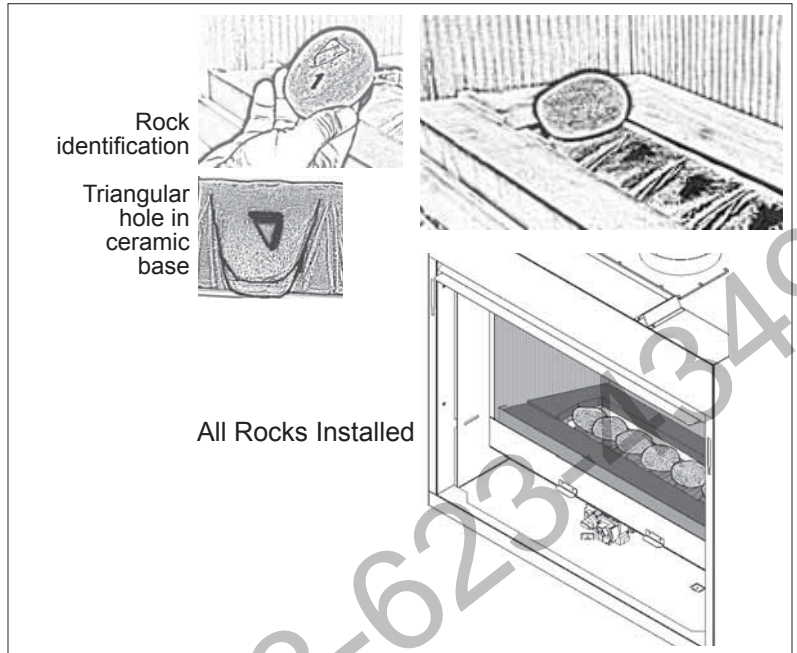

- 5. Place the glass panel in its cavity formed by the Front Support and the Ceramic Platform.

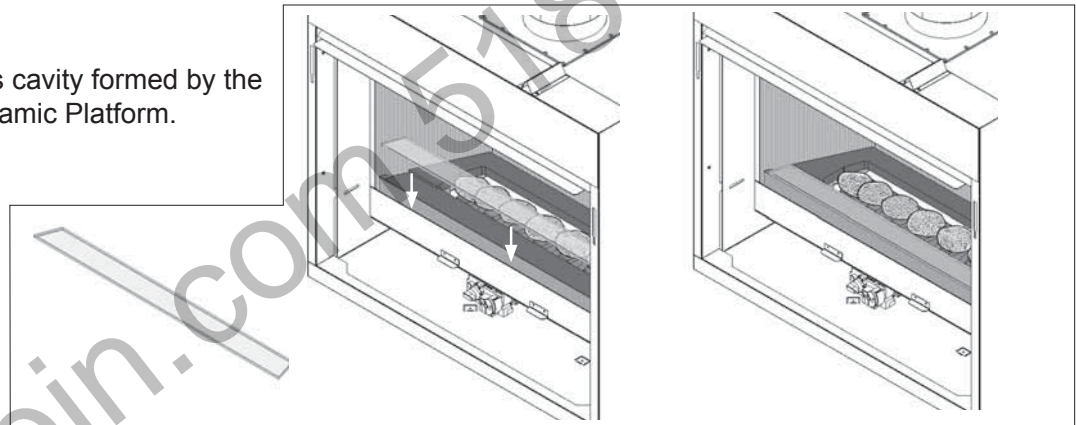

- 6. Place the left twig across the second and third rocks from the left; rest its end on the glass near the edge of the platform as shown. **Make sure to leave a gap between the twig and the first rock to allow flame to come up between the twig and the rock.**



- 7. Place the right twig across the second and third rocks from the right; rest its end on the glass about 1 cm from the edge of the platform as shown. **Make sure to leave a gap between the twig and the first rock to allow flame to come up between the twig and the rock.**

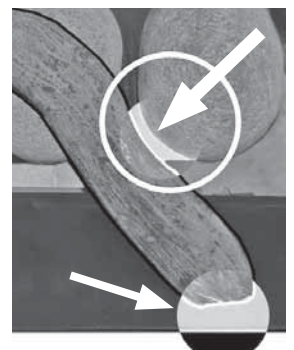
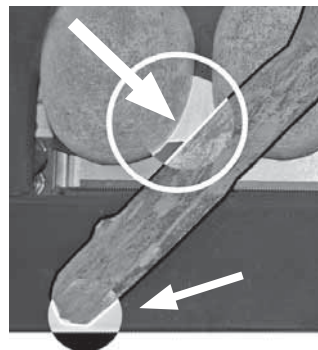
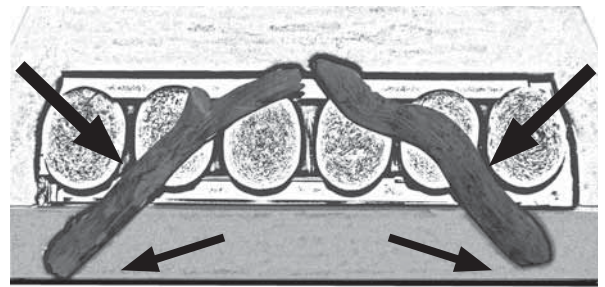

## Window Refitting & Baffle Installation

1. Slide the window inside the appliance case and rest it on the firebox front bottom tabs. Refit the bottom two bolts. The bolts should be screwed in securely.
2. Refit the top two bolts securing by turning them through 90 degrees.

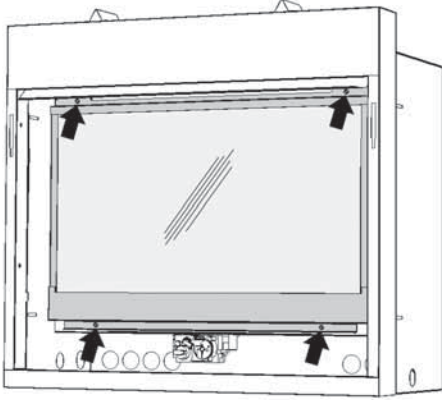

3. Hook the window baffle to the top of the window frame. *Be careful not to hook it onto the firebox frame—see images below.*

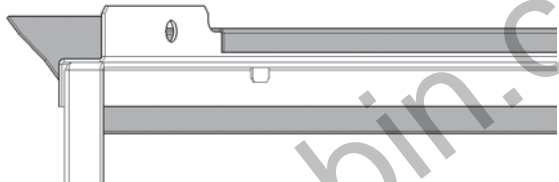
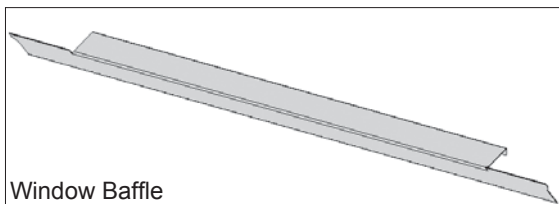

Rear view detail—window assembly with window baffle hooked on frame

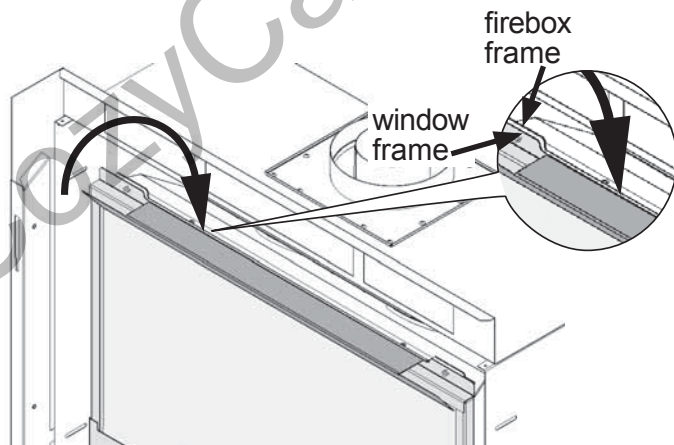

(appliance shown without its front frame and baffles for clarity)

4. Grab the top of the window and baffle and pull them forward and release to check that the window opens slightly and returns confirming the good function of the spring-loaded mechanism.
5. Similarly check the bottom of the window by pulling it forward and releasing.

**IMPORTANT:** To ensure a safe operation, ensure that the spring-loaded mechanism functions properly.

6. Apply light hand pressure against the window frame sides to bed in the window seal.
7. **If the Hot Glass Warning plate has been removed from the front lower corner of the window, reinstall it by sliding it between the glass and the frame as indicated.**

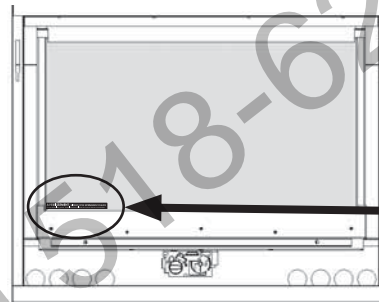

**! WARNING: EXTREMELY HOT GLASS AND FIREPLACE**  
Risk of severe burns. Keep Children away from fireplace & controls.  
**AVERTISSEMENT - VITRE ET FOCES EXTREMEMENT CHAUDES**  
Risque de graves brûlures. Garder les enfants à l'écart de la cheminée et des commandes.

Safety warning plate

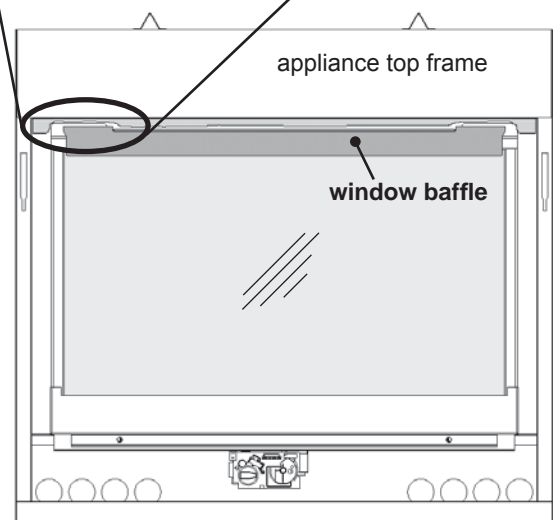
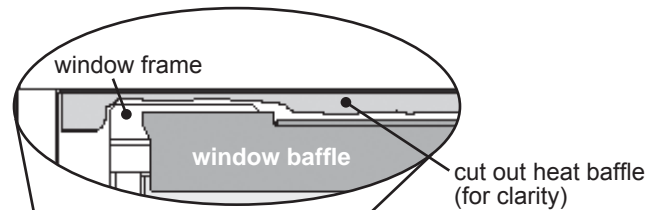

Appliance front view

**⚠ WARNING**  
**FOR SAFETY PURPOSE, the wall switch kit provided with this appliance MUST BE INSTALLED.**

**CAUTION**  
**DO NOT PUT BATTERIES IN THE REMOTE CONTROL RECEIVER** until the wires are connected to the burner control unit as short-circuit could result in the destruction of the electrical components.

The wall switch kit provided with this appliance must be installed. It is connected to the receiver in the fireplace. The receiver is located left of the control valve under the burner module.

1. Decide where the switch is to be installed. Install an electrical outlet box or mud ring as required (not supplied).
2. Thread the switch wire through an access hole in the appliance.

**CAUTION**  
**Do not run the switch wire over the top of the firebox.** Route the wire so it does not contact the firebox.

3. Pull out the receiver box. **Remove the batteries from the receiver box if it contains any.** You can remove the ignition wire to improve access to the receiver.
4. Take the switch wire and plug it into the receiver's connection slot as indicated (the other slot should already be fitted with the valve's wire harness connector). See diagrams below.  
**IMPORTANT: The connection can only be done one way. Do not force it or damage the pins!**
5. On the outside of the fireplace, run the switch wire into the outlet box. Use insulated type staples to secure the wiring to framing.
6. Plug the wire into the switch plate and to the outlet box.
7. Reconnect the ignition wire to the receiver if it was previously removed.  
**IMPORTANT: Make sure the ignition wire DOES NOT TOUCH the receiver's antenna.**
8. Insert 4 AA alkaline batteries in the receiver. Replace the cover.
9. Test the operation of the wall switch—see page 13.
10. Fix the wall cover plate to the outlet box.
11. Replace the receiver in its position and as well as the antenna if deployed.  
**IMPORTANT: The antenna MUST NOT TOUCH the ignition wire.**

**CAUTION**  
**DO NOT USE** a screwdriver or other metallic object to remove the batteries from the receiver or the handset! This could cause a short circuit to the receiver.

**CAUTION**  
 To avoid short-circuit to the receiver, position the **antenna** so that it **DOES NOT TOUCH the ignition wire.**

**IMPORTANT: The connection can only be done one way.**

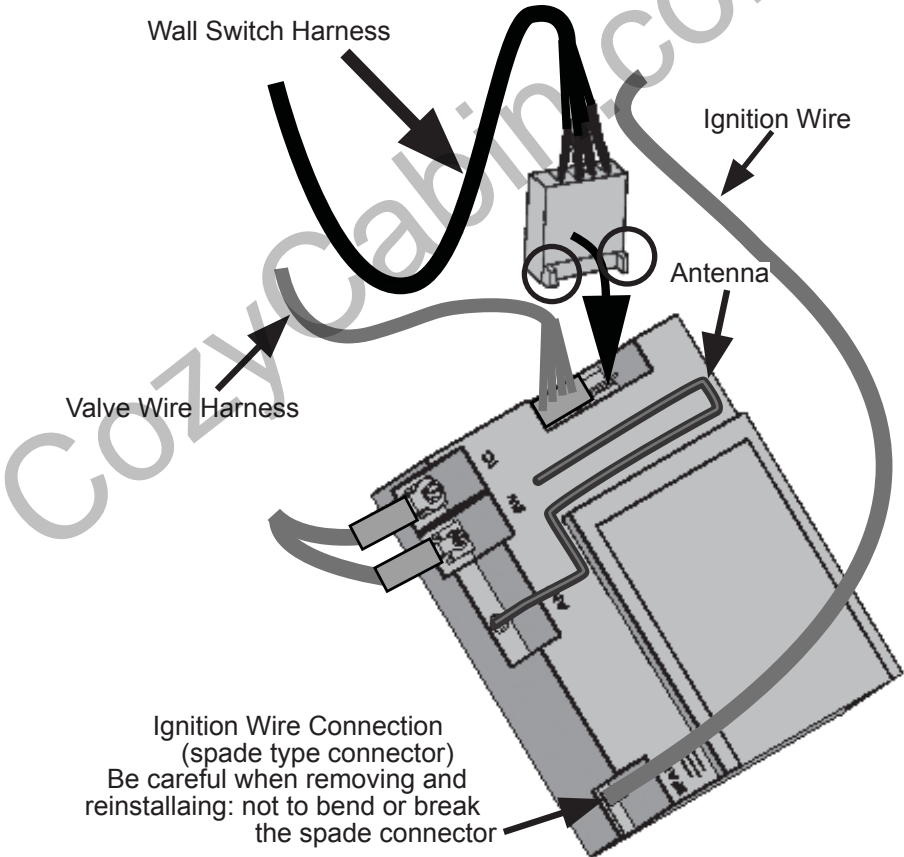
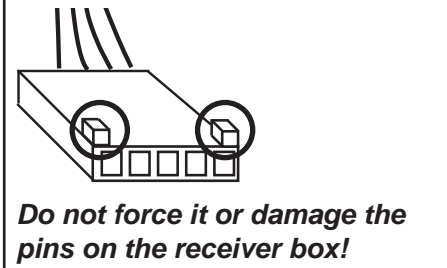

## Remote Control Initial Set-up

The receiver and the handset of the remote control system must be initially synchronized before the first use.

1. Insert alkaline batteries in the remote control receiver and handset. The receiver is located left of the control valve under the burner module.
2. With a sharp object, press and hold the receiver's reset button until you hear one short and one long beeps. Release the reset button after the second beep.
3. Within the subsequent 20 seconds, press the small flame button (  ) on the remote handset until you hear two short beeps confirming the synchronization is set.

This is a one time setting only and is not required when changing the batteries in the remote receiver. The remote control system is now ready to use.

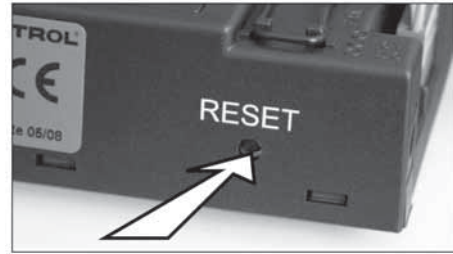

## Operation Check & Aeration Settings Adjustment

### Operation Check

Turn the fireplace flame up and down using the remote control to confirm that the full range of inputs is achieved—see the remote control operation instructions on pages 9–13.

### Aeration Settings

Light the fire and allow the unit to warm up for 10–15 minutes to evaluate the flame picture. Burners are equipped with an adjustable shutter to control primary aeration. See the figures below. The shutter is factory-set to an aeration gap which will give optimum performance for the vast majority of installations.

#### Air Shutter

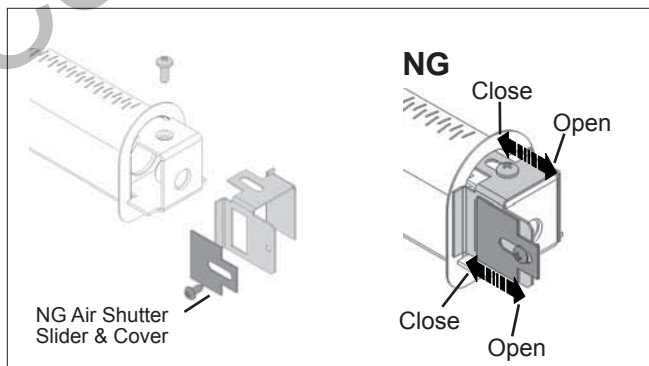

In a few unusual installations, the flame picture may be improved by adjusting the aeration. The need for adjustment should be determined only by operating the appliance with the ceramic rocks and window installed.

**Increasing aeration** will cause the flames to appear more transparent and blue showing more ceramic effects glow.

**Decreasing aeration** will cause the flames to appear more yellow or orange showing less ceramic effects glow.

**Too little aeration may result in black carbon forming and dropping into the firebox.**

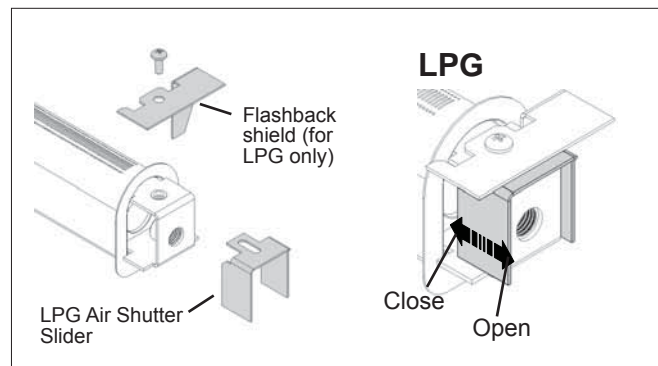

## Remote Control Handset Wall Holder Installation

The remote control kit for this fireplace comes complete with a wall-mounted holder. This holder is not required in all installations but is provided as an optional feature for those customers who wish to mount the remote handset to the wall.

To install the holder to the wall, find a convenient location and use the hardware provided with the kit. See the diagram on the right for required hardware and configurations. Note that the holder can be installed at the base of a light switch plate.

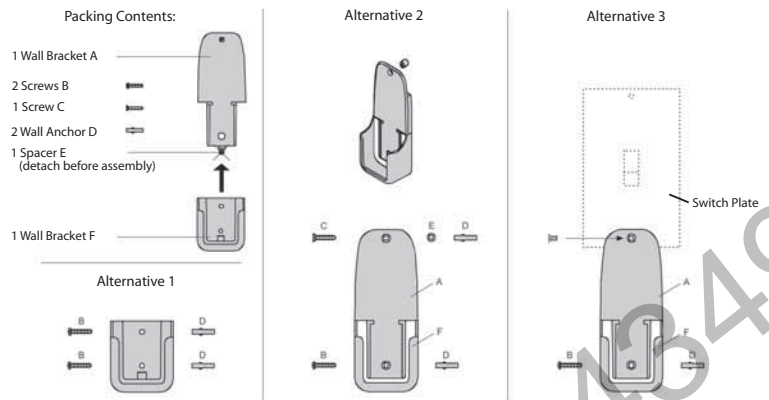

**IMPORTANT.** The location of the remote control handset is important to assure proper temperature regulation. To obtain a constant temperature, we recommend that the handset should be between 3 and 15 feet away from the appliance **but not directly above it**. We also advise that the handset should be located away from any other heat source and not in direct sunlight as this may affect the temperature sensor located in the remote handset.

# Wiring Diagram

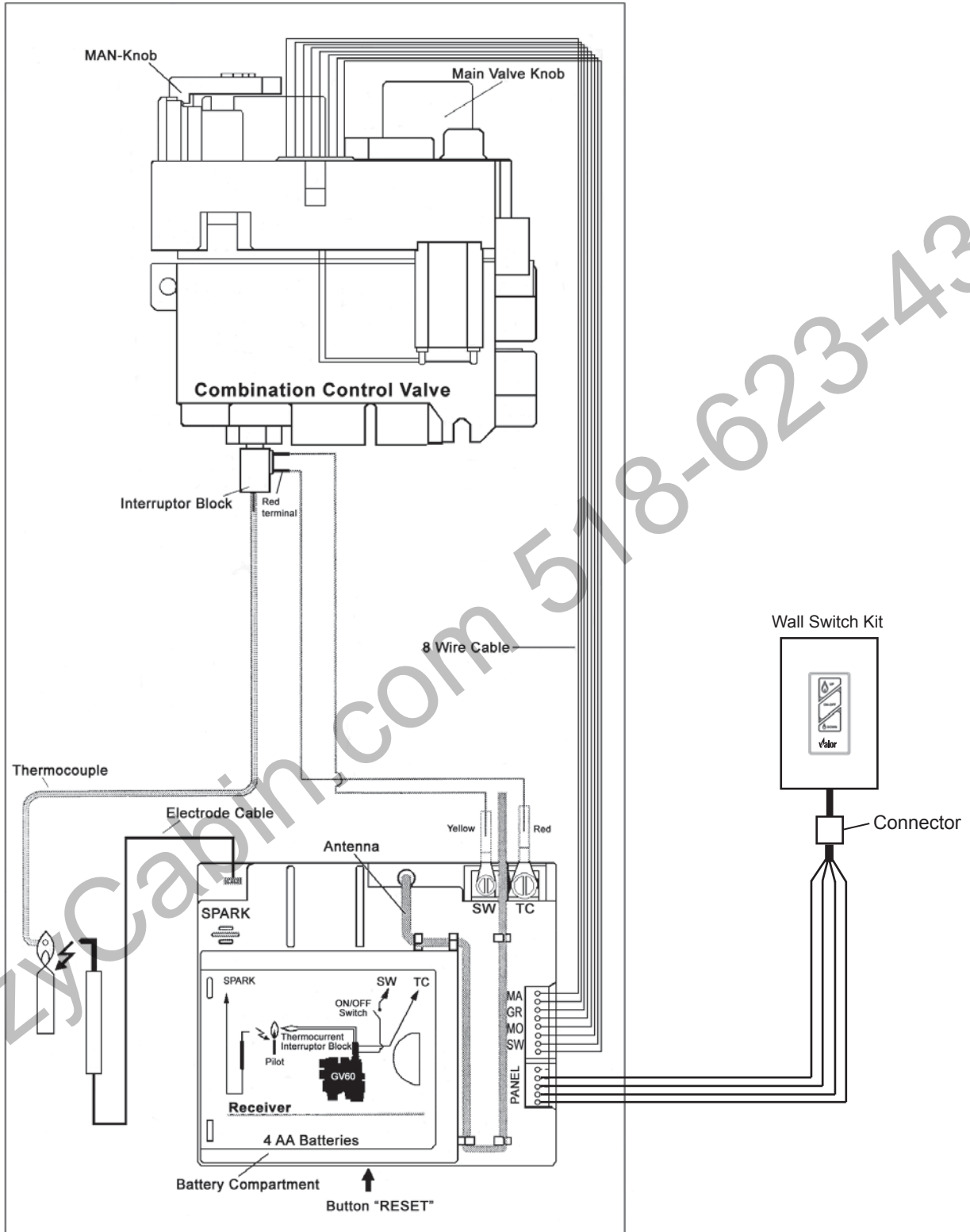

GV60 Wiring Diagram

# Approved Venting Components

**QUALIFIED  
INSTALLER**

Approved Direct Vent Suppliers for Valor Models 530, 534, 535, 650, and MF28			Venting Parts Code / availability by Manufacturer							
Venting Parts Description			DURA-VENT	SELKIRK	ICC EXCEL DIRECT	SECURE VENT	RLH INDUSTRIES	AMERIVENT	MILES INDUSTRIES	
Termination Caps	Horizontal	Co-axial Kit, 26" long	—	—	—	—	—	—	551DVK	
		Standard Co-axial	46DVA-HC	4DT-HC	TM-4HT	—	—	4DHC round	—	
		Deluxe Co-axial	—	—	TM-4DHT	—	—	4DHCS square	—	
		High Wind Co-axial	—	—	—	SV4CHC	—	—	—	
	Vertical	Standard Co-axial	46DVA-VC	4DT-VC	TM-4VT	—	HSDV4658-1313	4DVC 4DH-1313	—	
		High Wind Co-axial	46DVA-VCH	—	—	SV4CGV	—	—	—	
		Extended Co-axial	46DVA-VCE	—	—	—	—	—	—	
		Co-linear	—	—	—	—	3PDVCV	HS-C33U-99	HCL-99-33	559CLT
			—	—	—	—	—	HS-C33F-1313	HCL-913-33 HCL-1313-33	
		Snorkel, 14" Rise	46DVA-SNK14	4DT-ST14	TM-4ST14	—	—	—	4D14S	—
Snorkel, 36" Rise	46DVA-SNK36	4DT-ST36	TM-4ST36	—	—	—	4D36S	—		
Vent Adapters / Couplers	Universal Adapter 3" Flex Coupler	2150	—	TM-CFAA3	—	—	—	—		
	Valor Adapter	817VAK	—	—	—	—	4DSC-V	—		
	Co-linear Flex Connector	46DVA-ADF	—	—	—	—	—	—		
	Co-axial-to-Co-linear Adapter	46DVA-GCL	—	TM-4CAA	—	—	—	4DCAB33	556CLA	
	Co-linear-to-Co-axial Adapter	46DVA-GK	—	TM-4CTA	—	—	—	4DCAT33	—	
Aluminum Flexible Liner	3" diameter		NOTE: 2-ply liner approved to CAN/ULC S635 suitable for venting gas appliances. As manufactured by Z-Flex, Flexmaster or others.							
	2280 Series		3" ACFL	—	—	—	—	3AFL-35	—	
Adjustable Pipe Length 4" x 6-5/8"	4" to 10"	Galvanized	—	4DT-ADJ	—	—	—	4D7A or 4D7AB (3" to 5")	—	
		Black	—	4DT-ADJ(B)	—	—	—	—	—	
	1-1/2" to 6"	Galvanized	—	—	—	SV4LA	—	4D12A or 4D12AB (3" to 10")	—	
		Black	—	—	—	SV4LBA	—	—	—	
	1-1/2" to 12"	Galvanized	—	—	TC-4DLT	SV4LA12	—	4D16A or 4D16AB (3" to 14")	—	
		Black	—	—	TC-4DLTB	SV4LBA12	—	—	—	
	1-1/2" to 24"	Galvanized	—	—	—	SV4LA24	—	4D26A or 4D26AB (3" to 24")	—	
		Black	—	—	—	SV4LBA24	—	—	—	
DV 45° Elbows	Galvanized	46DVA-E45	—	TE-4DE45	—	—	4D45L	—		
	Black	46DVA-E45B	—	TE-4DE45B	SV4EBR45	—	4D45LB	—		
	Galvanized Swivel	—	4DT-EL45	—	SV4E45	—	—	—		
	Black Swivel	—	4DT-EL45(B)	—	SV4EB45	—	—	—		
DV 90° Elbows	Galvanized	46DVA-E90	—	TE-4DE90	—	—	4D90L	—		
	Black	46DAV-E90B	—	TE-4DE90B	SV4EBR90	—	4D90LB	—		
	Galvanized Swivel	—	4DT-EL90	—	SV4E90	—	—	—		
	Black Swivel	—	4DT-EL90(B)	—	SV4EB90	—	—	—		

## Approved Venting Components

Venting Parts Description			Venting Parts Code / availability by Manufacturer						
			DURA-VENT	SELKIRK	ICC EXCEL DIRECT	SECURE VENT	RLH INDUSTRIES	AMERIVENT	MILES INDUSTRIES
Pipes 4" x 6 5/8" ( ID x OD )	6" long	Galvanized	46DVA-06	4DT-06	TC-4DL6	SV4L6	—	—	—
		Black	46DVA-06B	4DT-06(B)	TC-4DL6B	SV4LB6	—	—	—
	7" long	Galvanized	—	—	—	—	—	4D7	—
		Black	—	—	—	—	—	4D7B	—
	9" long	Galvanized	46DVA-09	4DT-09	—	—	—	—	—
		Black	46DVA-09B	4DT-09(B)	—	—	—	—	—
	12" long	Galvanized	46DVA-12	4DT-12	TC-4DL1	SV4L12	—	4D12	—
		Black	46DVA-12B	4DT-12(B)	TC-4DL1B	SV4LB12	—	4D12B	—
	18" long	Galvanized	46DVA-18	4DT-18	—	—	—	—	—
		Black	46DVA-18B	4DT-18(B)	—	—	—	—	—
	24" long	Galvanized	46DVA-24	4DT-24	TC-4DL2	SV4L24	—	4D2	—
		Black	46DVA-24B	4DT-24(B)	TC-4DL2B	SV4LB24	—	4D2B	—
	36" long	Galvanized	46DVA-36	4DT-36	—	SV4L36	—	4D3	—
		Black	46DVA-36B	4DT-36(B)	—	SV4LB36	—	4D3B	—
	48" long	Galvanized	46DVA-48	4DT-48	TC-4DL4	SV4L48	—	4D4	—
		Black	46DVA-48B	4DT-48(B)	TC-4DL4B	SV4LB48	—	4D4B	—
Flashings	Roof Flashing 0/12-6/12		46DVA-F6	4DT-AF6	TF-4FA	SV4FA	—	4DF (0/12-5/12)	—
	Roof Flashing 7/12-12/12		46DVA-F12	4DT-AF12	TF-4FB	SV4B	—	4DF12 (6/12-12/12)	—
	Flat Roof Flashing		46DVA-FF	—	TF-4F	SV4F	—	—	559FSK
	Masonry Flashing		—	—	TF-4MF	—	—	—	—
Various Venting System Parts	Wall Thimble		46DVA-WT	4DT-WT	TM-4WT	SV4RSM	—	4DWT	—
	Storm Collar		46DVA-SC	4DT-SC	TM-SC	SV4AC	—	4DSC	—
	Decorative Plate		46DVA-DC	4DT-CS	TM-4TR	SV4PF	—	4DFPB	—
	Cathedral Ceiling Support		46DVA-CS	4DT-CCS	—	—	—	4DRSB	—
	Ceiling Firestop / Floor Support		46DVA-FS	4DT-FS	TM-CS	SV4BF	—	4DFSP	—
						SV4SD			
	Attic Radiation Shield / Firestop		—	—	TM-4AS	—	—	4DAIS12 (12")	—
								4DAIS36 (36")	
	Wall Strap		46DVA-WS	4DTWS	TM-WS	—	—	4DWS	—
	Vinyl Siding Standoff		46DVA-VSS	4DT-VS	TM-VSS	SV4VS	—	4DHVS	—
Elbow Strap / Offset Support		46DVA-ES	4DT-OS	TM-OS	—	—	—	—	
Terminal Guard		46DVA-WG	—	—	—	—	—	835TG	

- Notes:**
- 1) All listed above co-axial pipes and fittings require Valor 817VAK Adapter Kit to fit Valor's smooth collars (Valor adapter 4DSC-V by American Metal Products may also be used).
  - 2) Follow instructions supplied with each manufacturer's components.
  - 3) Unless otherwise specified, all the parts and assemblies from the above table are to be used with 4" x 6-5/8" pipes.
  - 4) **Do not mix components from different vent manufacturers.**
  - 5) Termination caps manufactured by RLH Industries or American Metal Products are from *Homestyle Chimney Collection* and can be ordered in one of the following finishes: a) aluminium; b) black powder coated; c) solid copper.

# Warranty

If you have a problem with this unit, please contact your dealer or supplier immediately. Under no circumstances should you attempt to service the unit in any way by yourself. The warranties in paragraphs 1 and 2 are provided only to the first purchaser/user of this unit, are not transferable and are subject to the conditions and limitations in paragraphs 3, 4 and 5. Please review the conditions and limitations carefully and strictly follow their requirements.



## 1. Extended Warranty Coverage

For a period of up to ten (10) years, Miles Industries Ltd., (the “Company”) or its appointed distributor will at its option pay the initial purchaser for the repair of, or will exchange the following parts or components which are found to be defective in material or workmanship under normal conditions of use and service:

Part or Component	Defect Covered	Maximum Warranty Period
Exterior steel casing	Corrosion	10 years
Glass	Loss of structural integrity	10 years
Cast iron parts	Corrosion	10 years
Firebox and heat exchanger	Corrosion (but not discoloration) causing loss of structural integrity	10 years

## 2. Two-Year Parts Warranty

In addition, for two (2) years from the date of purchase, the Company, at its option, can repair or exchange all parts and components not listed above but that are found to have a *bona fide* defect in material or workmanship under normal conditions of use.

## 3. Conditions and Limitations

- a) The warranty registration card must be completed by the initial owner and returned to the Company within 90 days of purchase.
- b) Installation and maintenance must be performed by an authorized and trained dealer in accordance with the Company’s installation instructions.
- c) This warranty is void where installation of the unit does not conform to all applicable codes including national and local gas appliance installation codes and building and fire codes.
- d) The owner must comply with all operating instructions.
- e) The Company is not responsible for the labor costs to remove defective parts or re-install repaired or replacement parts.
- f) The first purchaser or user of the unit will be responsible for any shipping charges for replacement parts as well as travel time incurred by the dealer to perform the warranty work.
- g) This warranty applies to non-commercial use and service and is void if it is apparent that there is abuse, misuse, alteration, improper installation, accident or lack of maintenance to the unit.
- h) This warranty does not cover damage to the unit through:
  - i) Improper installation, operational or environmental conditions.
  - ii) Inadequate ventilation in the area or competition for air from other household equipment or appliances.
  - iii) Damage due to chemicals, dampness, condensation, or sulphur in the fuel supply lines which exceeds industry standards.
- i) This warranty does not cover glass, log breakage or damage to the unit while in transit.
- j) The Company does not allow anyone to extend, alter or modify this warranty and assumes no responsibility for direct, indirect or consequential damages caused by the unit. State or provincial laws where the first purchaser or user resides may provide specific rights to extend this warranty and, if so, the Company’s sole obligation under this warranty is to provide labor and/or materials in accordance with those laws.

## 4. Discharge of Liability

After two (2) years from the date of purchase, the Company may, at its option, fully discharge all obligations under this warranty by paying to the first purchaser/user the wholesale price of any defective parts.

## 5. No Other Warranty

All obligations to repair this unit are defined in this warranty. Some states or provinces may specifically mandate additional warranties on the part of manufacturers, but in the absence of such specific legislation, there is no other warranty or obligation expressed or implied.

## Replacement Parts

Key	Description	Part no.
1	Outer vent collar	330A888
2	Blanking plate	330A964
3	Side frame fixing brackets (2)	3000255
4	Rear log support	4001999
4a	Rear log support spacers (2)	4002870
5	Burner module NG	4001952
	Burner module LPG	4001953
6	Window assembly	3000389S
7	Window baffle	4001970
8	Restrictor plates (2)	4002895
9	Adjustable plates (2)	4002896
	Screws (2) (not shown)	100A757
11a	Flashback shield LPG	3000371
11b	Air shutter cover NG	4002346
12a	Air shutter slider LPG	320B293
12b	Air shutter slider NG	4002345
13	Burner NG	740K189
	Burner LPG	740K190
14	Injector elbow 82-650 NG	9730012
	Injector elbow 92-260 LPG	9730007
15	Burner mounts (2)	4001964
16	Front log supports (2)	4001965
17	Pilot assembly NG	4000062S
	Pilot assembly LPG	4000063S
18	Pilot bracket	720A542
19	Pilot injector no. 35 NG	4002511
	Pilot injector no. 27 LPG	720A195
20	Hooked olive for pilot injector	720A196
21	Olive nut for pilot pipe	420K385
22	Electrode	720A543
23	Electrode retaining nut	720A200
24	Thermocouple	4000061
25	Pipe—valve to pilot	030A226
26	Olive nut for pilot pipe	220K913
27	Pilot shield	4002203
28	Pilot support bracket	330A904
29	Pilot seal	620B995
30	Access plate	4001680
31	Pipe—valve to main burner	3000247
32	Burner plate	4001966
33	Gaskets—module plate sides (2)	3000399
34	Gaskets—module plate front & back	3000400
35	Valve mounting bracket	4002885
36	Thermocurrent interruptor	4001037

Key	Description	Part no.
40a	GV60 Valve assembly NG	4003095
40b	GV60 Valve assembly LPG	4003108
41	Ignition cable 500 mm	4001039
41a	Ignition cable sleeve	4002244
42	Cable interruptor	4001035
43	Handset wall holder	9000008
44	Wiring harness	4001187
45	Handset G6R H3T5-ZV (BJ)	4001910
46	Receiver G6R-R3AM-ZV (CP)	4001911
47	Wall switch kit	1265WSK
48	Liner panels—complete set	
a	Enamel black	618EBL
b	Ceramic fluted black	620FBL
c	Valor red brick	621VRL
d	Ledgestone	622LSL
49	Rear panel	
a	Enamel black	4002085
b	Ceramic fluted black	4002109
c	Valor red brick	4002105
d	Ledgestone	4002113
50	Left side panel	
a	Enamel black	4002087
b	Ceramic fluted black	4002107
c	Valor red brick	4002103
d	Ledgestone	4002111
51	Right side panel	
a	Enamel black	4002086
b	Ceramic fluted black	4002108
c	Valor red brick	4002104
d	Ledgestone	4002112
52	Top panel	
a	Ceramic plain black	4002110
b	Ceramic plain black	4002110
c	Valor red brick	4002106
d	Ledgestone	4002114
53	Log set complete	4001696
54	Rear log	4001697
55	Front left log	4001699
56	Front right log	4001700
57	Right cross log	4001701
58	Middle cross log	4001698
59	Left cross log	4001772
60	12-inch Top stand-off	4002121
61	Rock Set Complete	4001791



## Replacement Parts

Key	Description	Part no.
62	Rock No. 1	4001821
63	Rock No. 2	4001822
64	Rock No. 3	4001823
65	Rock No. 4	4001824
66	Rock No. 5	4001825
67	Rock No. 6	4001826
68	Rock Base	4001792
69	LH Twig	4001827
70	RH Twig	4001828
71	Front Support—Platform	4001998AH
72	Ceramic Platform	4001997
73	Glass Panel	4001836
74	Hot Glass Warning Plate	4003093

CozyCabin.com 518-623-4349

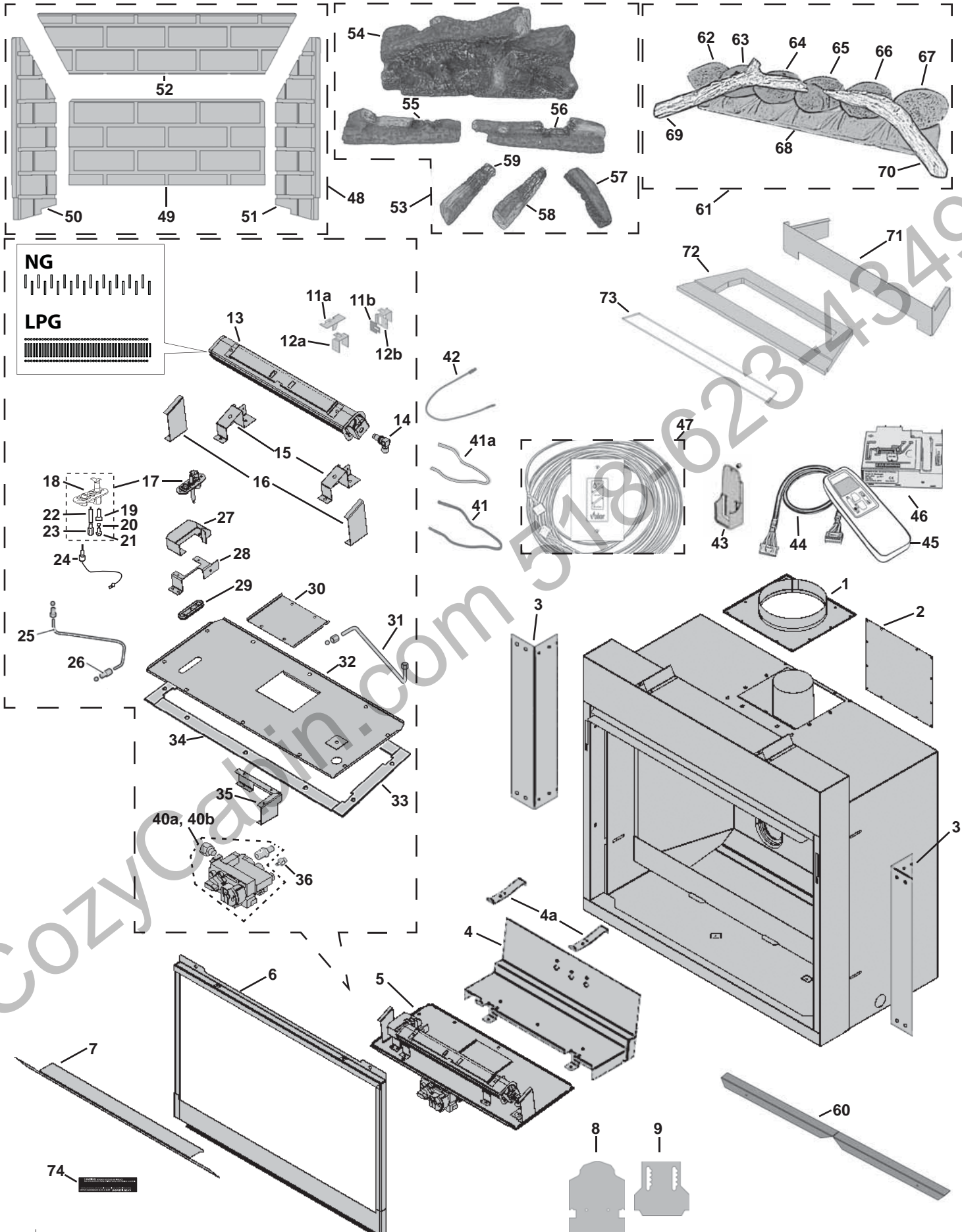
**OWNER'S  
INFORMATION**



**NG**  
  
**LPG**  

## Thank You ...

For purchasing a Valor by Miles Industries. Your new radiant gas heater is a technical appliance that must be installed by a qualified installer.

**Please fill in the information below. The information provided will be used for customer records only.**



### Fireplace Information

Model Number: 650I  LN  LP  RN or  RP

Serial Number:

Date Purchase (yyyy-mm-dd):

Dealer:

### Customer Information

First Name:

Last Name:

### Contact Information

Email:

### Mailing Address

Address:

City:

Province/State:

Postal/Zip Code:

Country:

Cut out page, fill information, and mail to Miles Industries Ltd.

Online Warranty registration at [www.valorfireplaces.com](http://www.valorfireplaces.com)



Tape Shut



Fold here



Postage  
needed

Miles Industries Ltd.  
190 - 2255 Dollarton Highway  
North Vancouver, BC V7H 3B1  
Canada

Online Warranty registration at [www.valorfireplaces.com](http://www.valorfireplaces.com)



*Thank you for choosing a Valor Product*